

ASSEMBLY INSTRUCTIONS

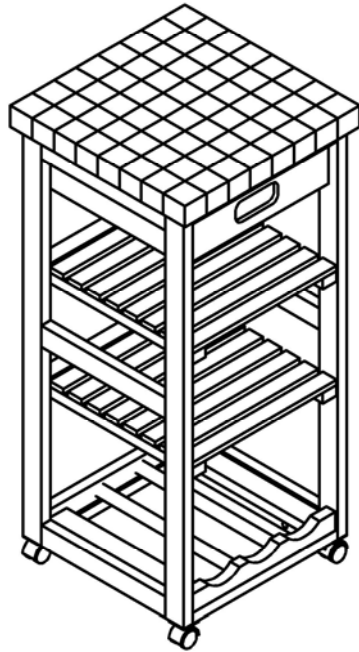

PLS NOTE: THE BUTHER BLOCK TOP HAS BEEN TREATED WITH SYNTHETIC OIL, WHICH WILL ENHANCE THE GRAIN OF THE WOOD.

BUT, MOST IMPORTANTLY, THIS TREATMENT WILL ASSIST IN MINIMIZING POTENTIAL CRACKING OF THE WOOD.

WE STRONGLY RECOMMEND TREATING THE TOP ABOUT EVERY 6 MONTHS, IN ORDER TO MAXIMIZE THE LIFE OF YOUR ISLAND.

WHEN YOU APPLY OIL, PLS BE SURE THAT THE OIL IS SAFE FOR CONTACT WITH FOOD.

Do not use vegetable or olive oils because they can turn rancid. Food Grade Mineral oil remains safe throughout its life. There are various oils available for cutting boards and butcher blocks. Some are called "Butcher Block Finishes" or "Mystery Oil." Save some money by visiting the local hardware or drug store and purchasing Mineral Oil. (not mineral spirits - this is paint thinner)

When you see the words "food safe finish" in a description of a wood product, this generally means mineral oil has been used. Simply wipe mineral oil on the surface of your board and watch it soak in. When the wood won't take any more oil, you can wipe off the excess with a clean dry cloth. Don't worry about applying too much oil - more is better.

Description : TROLLEY CART
Item No. : WC-1515

BEFORE ASSEMBLY

Thank you for purchasing this quality product. This product has been designed for easy assembly and constructed for durability. All parts were checked prior to packaging to insure quality. Prior to beginning assembly, however, make sure all parts and hardware are included and free of obvious defect. If a part is missing or defective, please contact the store where purchased. If hardware is missing, or you need help with assembly, please call toll free 888-944-8396.

IMPORTANT NOTE:

- Place all wooden parts on a clean and smooth surface such as a rug or carpet to avoid the parts from being scratched.
- Remove all wrapping material, including staples & packing straps before you start to assemble.
- DO NOT tighten all screws and bolts until completely assembled.
- Keep all hardware parts out of reach of children.

WARNING:

Long exposure to rubber or soft plastic may cause a chemical reaction and damage the finish of your product. Protect the surface of the product with cloth if you are using any product with rubber feet or base.



ASSEMBLY TOOLS REQUIRED



NOT INCLUDED



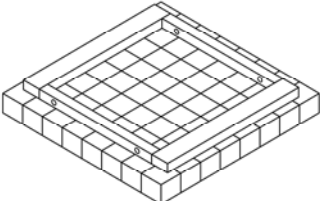

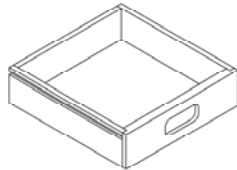
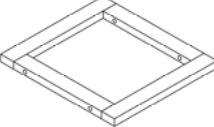
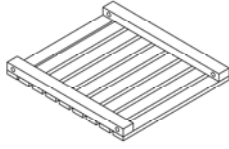
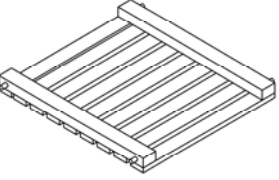
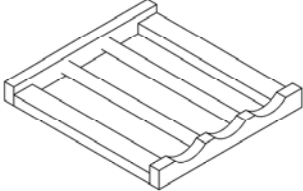
PART LIST

When unpacking, please be careful not to discard any parts with the packaging. Before continuing, please make sure you have the following parts:

| NO | Description | Qty | Sketch | NO | Description | Qty | Sketch |
|----|-----------------------|-----|---|----|-----------------------|-----|---|
| A | Top | 1 |  | B | Side Frame (L-R) | 2 |  |
| C | Back Cross Bar | 1 |  | D | Drawer | 1 |  |
| E | Bottom Frame | 1 |  | F | 1 st shelf | 1 |  |
| G | 2 nd shelf | 1 |  | H | Wine Rack | 1 |  |

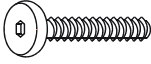
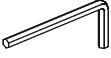
HARDWARE LIST

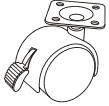
When unpacking, please be careful not to discard any parts with the packaging. Before continuing, please make sure you have all of the following hardware:

| NO | Description | Qty | Sketch | NO | Description | Qty | Sketch |
|----|---------------------------------------|-----|---|----|------------------------------------|-----|---|
| 1 | Bolt (M6 x 35mm) | 12 |  | 2 | Allen Key (4x80mm) | 1 |  |
| 3 | Screw (M3.5x15mm) | 16 |  | 4 | Castor With Lock (Dia. 40mm) | 2 |  |
| 5 | Castor Without Lock (Dia. 40mm) | 2 |  | | | | |

STEP 1

Attach the Top (A), Shelf (F) and Bottom Frame (E) to the Side frame (B) with Bolts (1) as shown below. Tighten with Allen key (2).

Insert Back Cross Bar (C) into the Side frame (B) as shown below.

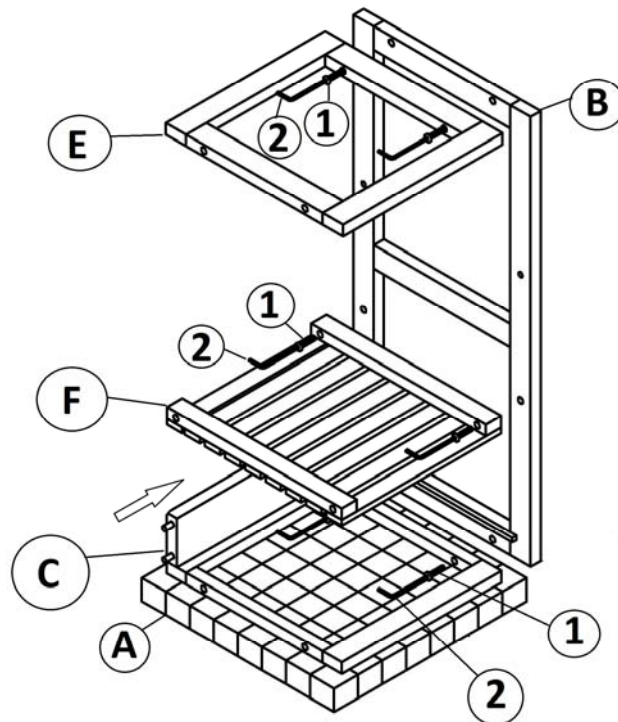

STEP 2

Insert shelf (G) into the unit and side frame (B), as shown below. Then attach the side frame (B) to the unit with Bolts (1) as shown below. Tighten with Allen key (2).

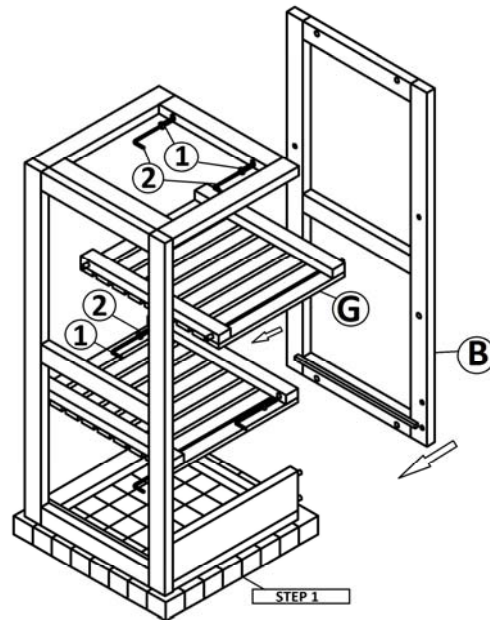

STEP 3

Attach Castors (4) and (5) to bottom of posts, using Screws (3). Tighten with the screwdriver.

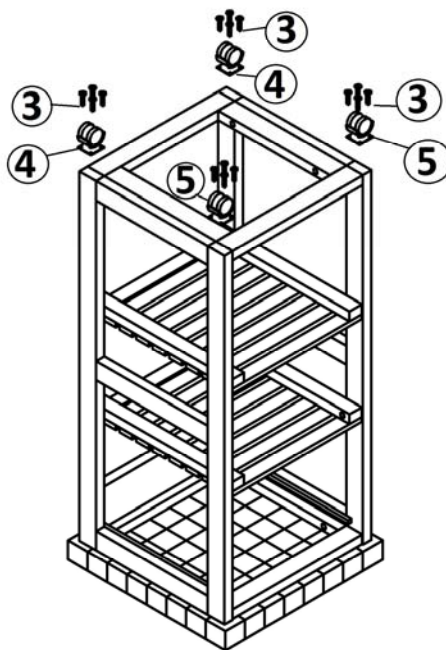

STEP 3

Insert Drawer (D) and Wine Rack (H) into the unit.

