

# FALCON



**LED WALLPACK**  
**100W | 9191 LUMENS | REPLACES 250W**

**ORDER NUMBER: L-FA100-4UD-P-Z**

## KEY BENEFITS

UL wet listed die-cast aluminum construction with tempered glass lens or borosilicate glass reflectors, complete with stainless steel hardware. Mounts to standard 4 inch square electrical junction boxes. Alternate junction box mounting possible via universal mounting ring. Ingress resistant gasket included. Same foot print as traditional HID fixtures

- Premium brand LED Philips® and YG® driver technology
- Dimming option available
- Precision die-cast Aluminum
- Wet location rated fixture for outdoor use
- Chip and fade resistant powder coat finish in any color
- Precision prismatic refractor
- Industrial grade, Button-type photocell.

## APPLICATIONS

Suitable for building-mounted doorway, pathway and security illumination

## CERTIFICATIONS

- DLC 4.1 Premium
- cUL-us Listed
- Lighting Facts



\* Please refer to the DLC QPL website for the latest and most complete information at [www.designlights.org/QPL](http://www.designlights.org/QPL)

## PRODUCT PERFORMANCE

SYSTEM WATTAGE	LED WATTAGE	LUMENS	LP/W	CRI	REPLACES (MH)
100W	90W	9191 lm	121 lm/w	≥80	250W

## PRODUCT SUMMARY

EFFICACY	121 lm/w
LED CHIP	Philips®
CCT	4000K
DRIVER	YG® driver technology, Dimmable LED power supplies, Current can be adjusted the 120-277V Dimming type is continuous, The product can dim to 10%
DRIVER EFFICIENCY	>85%
INDIVIDUAL CARTON DIMENSIONS	18 x 9 x 9 in
INDIVIDUAL CARTON WEIGHT	17 lbs
STANDARD LIFETIME	Design minimum 50,000 + hours
STANDARD WARRANTY	5 Years
WATER PROOFING GRADE	Wet Location

## PRODUCT WEIGHT: 17 lbs

## PRODUCT DIMENSIONS

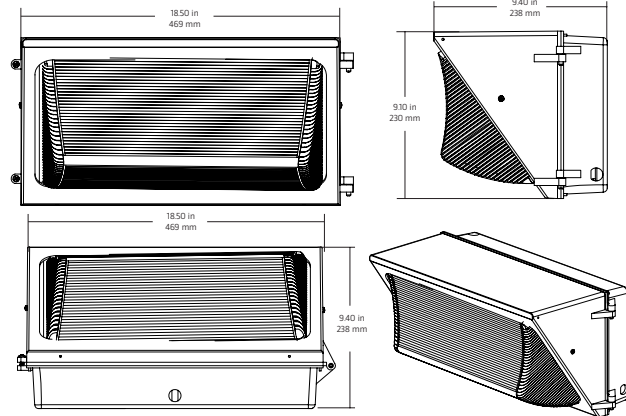

## PRODUCT PHOTOMETRY

