



# OWNER'S MANUAL



**Charcoal Grill  
Model #1515  
Patio Pro**



**Keep your receipt with this manual for Warranty.**

# PARTS LIST AND TOOLS REQUIRED

(Tools Not Included)

Pliers



and 7/16" nut driver

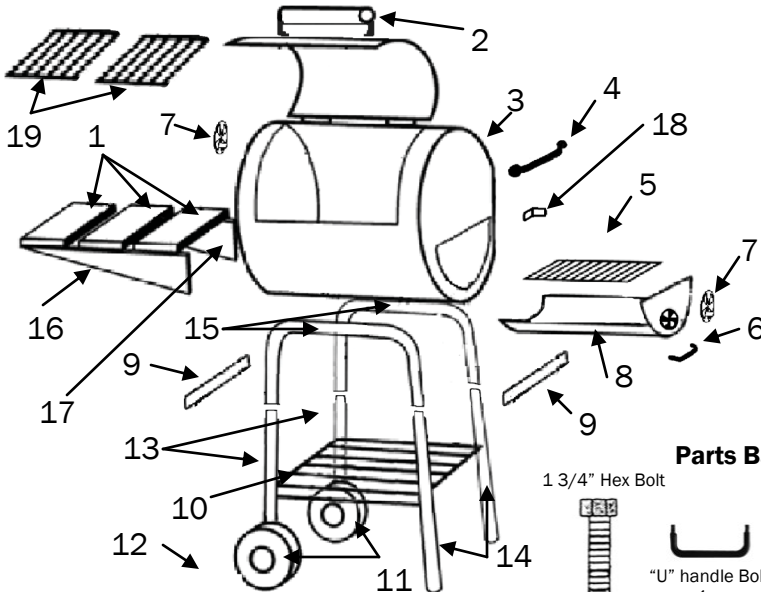

## Parts Bag Contains:

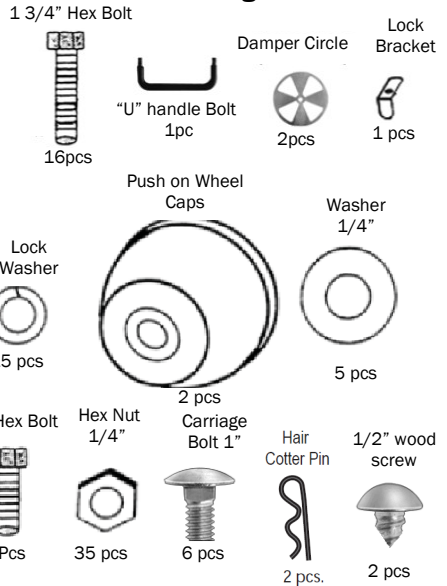

#	QTY	Part Name	Part #
1	3	SIDE SHELF SLAT	10-0113
2	1	HOOD HANDLE	55-0014
3	1	GRILL BODY	20-0102
4	1	WIRE HANDLE	55-0016
5	1	FIRE GRATE	20-0028
6	1	U HANDLE	55-0004
7	2	DAMPER CIRCLE	10-0036
8	1	ASH DRAWER	20-0100
9	2	LEG BRACE	10-0175
10	1	WIRE RACK	20-0103
11	2	WHEEL	55-0026
12	2	HUB CAP	55-0007
13	2	SHORT LEG	20-0106
14	2	LONG LEG	10-0174
15	2	LEG CROSS BAR	10-0173
16	1	SHELF BRACKET R	10-0124
17	1	SHELF BRACKET L	10-0114
18	1	DRAWER LATCH	10-0172
19	2	COOKING GRATE	10-0086

**No Returns on Used Grills**

**STOP! CALL  FIRST! DO NOT RETURN PRODUCT TO STORE.**

CALL (912) 638-4724 This product has been built to the highest quality standards. Call us should you have any questions not addressed in these instructions, or for service information.

**Have your grills serial number (located on the back of the grill body or on the leg) when calling.**

# ASSEMBLY INSTRUCTIONS

**Read all safety warnings and instructions carefully before assembling and operating your grill.**

**IMPORTANT HINT: DO NOT TIGHTEN ANY NUTS AND BOLTS UNTIL GRILL IS FULLY ASSEMBLED.**

1. Remove and unwrap the Patio pro and all of its parts from the packaging. Also remove the ash drawer from the Patio Pro. Place GRILL on its end with damper opening facing up. Spread if open in order to reach inside to perform the following.
2. Insert two BOTTOM LEGS into one CROSSBAR, attached with 1 3/4" hex bolt and nut, See below. Repeat this step for another two BOTTOM LEGS and one CROSSBAR, see below.

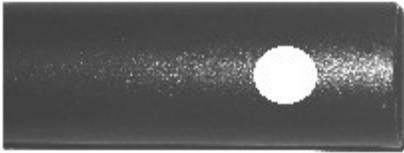

Crossbar



Leg

3. Attach LEG BRACES to the outside of one of the LONG and SHORT LEG assemblies you just made. See below. Use two 1 3/4" hex bolts and nuts for each LEG BRACE but only finger tight.

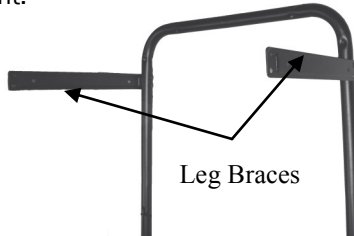

4. Insert all four corners of the BOTTOM WIRE SHELF into the four holes located near the bottom inside of the four LEGS. See below Next, rotate the LEGS upward until vertical. Important: Make sure the two Long Legs are on the same end.

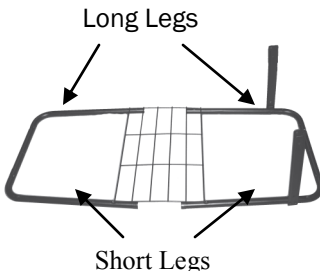

5. Attach the other end of the LEG BRACES to the corresponding legs using 1 3/4" Hex Bolts and Nuts but only finger tight. See below.

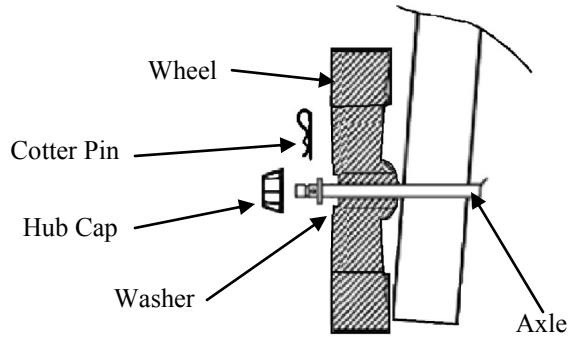
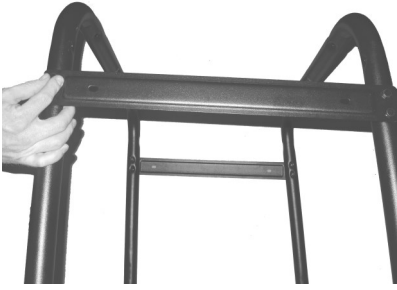

6. Attach the WHEEL to the spindle coming out of the SHORT LEGS. Install one WASHER, COTTER PIN and HUB CAP onto the spindle after the WHEEL. Repeat this on the opposite SHORT LEG.

7. Stand the CART/LEG ASSEMBLY upright. Attach the bottom half of the BODY to the CART/LEG ASSEMBLY (make sure damper is on same side as wheels) with four 1 3/4" Hex Bolts. There are two holes in the front and two in the back of the grill BODY. See below. Make sure the bolts are facing out with the hex nuts on the bottom of the leg assembly.



8. Attach WOOD HANDLE with two (2) 1/2" HEX BOLTS with two (2) LOCK WASHERS & two (2) HEX NUTS to BOLTS to center of front edge of hood. Snug tight with pliers. See Below.

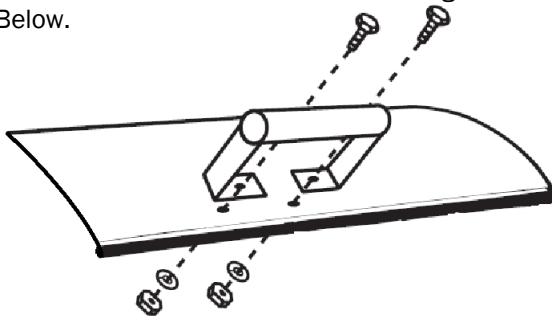

9. Attach SIDE HANDLE (metal rod) to the END of the GRILL above SIDE DRAWER with (2) 1/2" HEX BOLTS, (2) LOCK WASHERS, and (2) HEX NUTS.

10. Attach LOCK BRACKET to the End of the GRILL between SIDE HANDLE and SIDE DRAWER with one 1/2" hex bolt, one flat washer and one lock washer and on nut.
11. Attach two (2) SIDE SHELF BRACKETS to the four (4) holes on left side of grill with 1/2" hex bolts and nuts. Next, attach three (3) WOOD SLATS to the brackets with six (6) 1" carriage bolts and nuts. Then, holding shelf straight, screw two(2) 1/2" screws through bracket and into outer wood slat from underneath. See Below

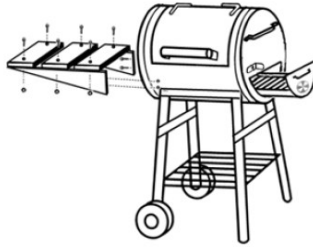

12. Attach the Damper circle to the inside of the Ash Drawer using 1/2" hex bolt, two flat washers, one lock washer and one nut. The bolt goes thru a Flat Washer, thru the ash drawer wall, thru the Damper Circle, thru another Flat Washer, thru Lock washer and finally attached to a Hex Nut. See below.

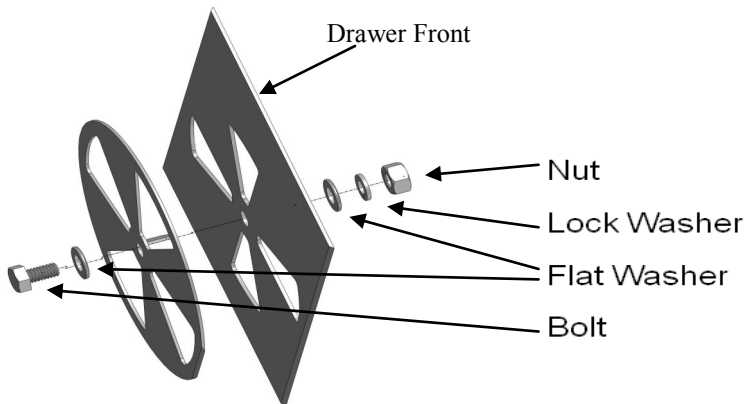

13. Attach the "U" Handle Bolt to the side for the Ash Drawer using two lock washers and nuts.
14. Attach the damper circle to the inside of the grill damper opening using one 1/2" hex bolt, two flat washers, one lock washer and one nut. See Step 12.
15. Tighten ALL Nuts and Bolts.
16. Place the grate into the ash drawer then slide the ash drawer into the FIRE BOX then place the cook grate into the FIRE BOX.

**NO RETURNS ON USED GRILLS.**

# GRILL PREPARATION & OPERATING INSTRUCTIONS

## PLEASE NOTE: NO RETURNS ON USED GRILLS

**Read all safety warnings and instructions carefully  
Before assembling and operating your grill.**

1. Cure GRILL prior to your initial use to protect the interior and exterior finish and to prevent unnatural flavors to your first meals. (A) Lightly coat ALL INTERIOR SURFACES (including GRILLS, GRATES, AND INSIDE OF BARREL.) with vegetable oil (spray vegetable oil is easiest but do not use near hot coals or fire). (B) Build a medium sized fire on the fire grate. (C) After coals ash over, spread out coals, replace cooking grates, close lid and heat at approximately 250 F for two hours. Re-coat GRATES and return to grill at approximately 200 F for two hours. You can lightly coat the exterior of the grill body (while warm) with vegetable oil. This will extend the life of the finish, much like waxing a car. Your GRILL will then be ready for use. NOTE: Grill will drip a lot of oil during this process and for several uses but will slow over time. **NEVER EXCEED 400 BECAUSE THIS WILL DAMAGE THE FINISH AND CONTRIBUTE TO RUST. PAINT IS NOT WARRANTED AND WILL REQUIRE TOUCH-UP. THIS UNIT IS NOT WARRANTED AGAINST RUST.**
2. To START FIRE – stack 15 briquettes in pyramid and saturate with lighter fluid (DON'T USE GASOLINE). Light coals in several places, close lid after briquettes ash over or \_ gray, spread them out and start cooking. If one end burns faster, use tongs to move coals from one end to the other for even heat. **ALWAYS FOLLOW CHARCOAL AND LIGHTER FLUID MANUFACTURERS' INSTRUCTIONS AND WARNINGS. USE OUTDOORS ONLY ON NONCOMBUSTIBLE SURFACE – 15' AWAY FROM WOOD AND COMBUSTIBLE MATERIAL.**
3. Control heat with amount and type of FUEL, DUAL DAMPERS and ADJUSTABLE FIRE GRATE. Adjust GRATE one end at a time. Wood burns hotter than coals. More airflow is more heat.
4. For no flare-ups, cook with lid in the down position. Add water soaked hardwood chips for a smoked flavor.
5. Suggestion: Screw 3/4" cup hooks (not furnished) on front of the wood shelf to hang cooking utensils.
6. Burn out may be rust out. Ashes left in bottom too long hold moisture and rust through any thickness of steel. This grill is made of steel and cast iron, which WILL RUST, ESPECIALLY IF NOT PROPERLY CARED FOR.
7. Do not use self-starting charcoal as it will give unnatural flavor. Burn lighter fluid completely before closing lid.
8. After using, coat vegetable oil on interior grates and bare metal while warm to reduce rust. On the EXTERIOR, remove dust with wire brush and touch up with a high heat paint, available at most hardware/auto stores.
9. You may place a coffee can on bottom shelf under the hole in the grill to catch drippings.
10. HEAT GAUGE may obtain moisture, which will steam out during cooking. Gauge may be calibrated in oven.
11. You may fill unwanted holes with Nuts & Bolts (Not Provided). NOTE: Smoke will escape from areas other than the smokestack. This should not affect your cooking.

## GRILLING RECIPES

### DIRECT METHOD

**STEAK (& ALL MEATS):** Cook food directly above coals/heat. Generally speaking, to grill meats, raise fire grate to high position (hot) and sear for one minute on each side with the lid open to seal in flavor and juices. Then lower fire grate to medium position with lid closed and cook to desire doneness. Control heat with dual dampers and adjustable fire grate.

**BETTER BARBECUE:** Place grilled meat back in the marinade for several minutes before serving – it will become tastier and juicier. CAUTION: Boil extra marinade first to kill bacteria remaining from the raw meat.

**Tip:** Cooking with a MEAT THERMOMETER ensures food is fully cooked. Insert into thickest part not touching bone & allow five minutes to register. Internal temperatures for BIRDS should be 170F to 180F and meat should be 140F for rare, 160F medium and 170F for well done.

**MARINATED FLANK STEAK:** Mix marinade ingredients in nonmetal dish. Let steak stand in marinade for no less than 4 hours in refrigerator. Brown each side for 5 minutes, but center should remain rare. Cut steak diagonally across the grain into thin slices before serving. Grill with fire grate in high (hot) position with lid open or closed.

**MARINADE:** 1/2 cup vegetable or olive oil, 1/3 cup soy sauce, 1/4 cup red wine vinegar, 2 tbs. Lemon juice, 1 tsp. Dry mustard, 1 minced clove garlic, 1 small minced onion, 1/4 tsp pepper.

**QUAIL OR DOVES:** Cover birds in Italian dressing (Good Seasons or Kraft Zesty), marinate overnight, pour off dressing and cover with Texas Pete Hot Sauce for 6 hours. Wrap birds in thick bacon secured by a toothpick. \*Place on grill – keep turning until bacon is black. Grill for 20 minutes. Sear with lid open and fire grate in high (hot) position for 1 min each side before lowering grate and closing lid. \*OR SMOKE by placing birds in center of GRID with fire in both ends of FIRE BOX.

**KABOBS:** Alternating on skewers any combination of meat, onions, tomatoes, green peppers, mushrooms, zucchini, circular slice of corn-on-the-cob, or pineapple. Meat could consist of chunks of shrimp, scallops, lobster, chicken, sausage, pork, beef, etc. Marinate the meat in refrigerator for several hours. Grill each side approximately 7 minutes turning occasionally while basting with marinade. Leave a small amount of room between pieces in order to cook faster. Grill with lid up and the fire grate in the lowest position. See marinade recipe on last page.

**KABOB MARINADE:** Mix 1 cup soy sauce, 1/2 cup brown sugar, 1/2 cup vinegar, 1/2 cup pineapple juice, 2 teaspoons salt, 1/2 teaspoon garlic powder and bring to a boil. Marinate beef in mixture a minimum of 4 hours.

**HOT DOGS:** Grill with lid up and fire grate in high (hot) position for approximately 6 minutes, turn every few minutes.

**HAMBURGERS:** Mix in chopped onions, green peppers, salt, sear 3/4 inch patties on each side with fire grate in high position for a few minutes. Lower fire grate to medium position and grill with lid down to avoid flare-ups. Cook each side 3 to 7 minutes according to desired doneness. Cook ground meat to 150 internally or until juice runs clear (free of blood) for prevention of E-coli. Burgers can be basted with marinade when turning and/or other ingredients can be mixed in with the ground beef such as chili sauce or powder; or you may marinate by allowing to stand in marinade for 1 or 2 hours at room temperature before cooking; or let stand in covered dish in refrigerator up to 24 hours. Bring to room temperature before cooking. See meat marinade on page 9.

**SHRIMP (Peeled) & Crayfish:** Place on skewers, coat with melted butter and garlic salt. Grill 4 minutes on each side or until pink. Cocktail sauce optional.

**BAKED POTATOES:** Rub with butter and wrap in foil and cook on grill with lid down for 50 minutes. Turn after 25 minutes (no need to turn if smoked). Squeeze to check for doneness.

**SWEET CORN IN HUSKS:** Trim excess silk from end and soak in cold salted water 1 hour before grilling. Grill 25 minutes – turning several times.





## **IMPORTANT SAFETY WARNINGS**

**READ ALL SAFETY WARNINGS AND INSTRUCTIONS CAREFULLY  
BEFORE ASSEMBLING AND OPERATING YOUR GRILL**

- Use caution when assembling and operating your grill to avoid scrapes or cuts from sharp edges.
- Do not use gasoline, kerosene or alcohol for lighting charcoal. Use of any of these or similar products could cause an explosion possibly leading to severe bodily injury.
- Keep children & pets away from grill. Supervision is necessary and do not leave grill unattended when in use. Use caution when moving grill to prevent strains. Keep grill at least 15 feet from any combustible material (decks, buildings, fences, trees, bushes, etc).
- When adding charcoal and/or wood, use extreme caution.
- Never move grill when it is in use or when it contains hot coals or ashes.
- Do not place grill near flammable liquids, gases or where flammable vapors may be present.
- Use caution since flames can flare-up when fresh air suddenly comes in contact with fire. When opening the lid, keep hands, face and body safe from hot steam and flame flare-ups.



## **IMPORTANT SAFETY WARNINGS**

### **READ ALL SAFETY WARNINGS AND INSTRUCTIONS CAREFULLY BEFORE ASSEMBLING AND OPERATING YOUR GRILL**

- Do not exceed a temperature of 400 F. Do not allow charcoal and/or wood to rest on the walls of grill. Doing so will greatly reduce the life of
- Always wear oven mitts to protect hands from burns. Avoid touching hot surfaces.
- When opening lid, make sure it is pushed all the way back so it rests against the lid support brackets. Use extreme caution as hood could fall back to a closed position and cause bodily injury.
- Close lid and all dampers to help suffocate flame.
- Always hold an open lid from the wooden handle to prevent it from closing unexpectedly.
- Never leave coals and ashes unattended. Before grill can be left unattended, coals and ashes must be removed. Use caution to protect yourself and property. Carefully place remaining coals and ashes in a noncombustible metal container and saturate completely with water. Allow coals and water to remain in metal container 24 hours prior to disposing.
- To protect against bacteria that could cause illness, keep all meats and refrigerated and thaw in refrigerator or microwave; keep raw meats separate from other foods; wash everything that contacts raw meats; cook thoroughly; and refrigerate leftovers immediately. Cook meats medium to well one.

**THESE WARNINGS APPLY ALSO TO THE "SIDE FIRE BOX"**

# ACCESSORIES ORDER FORM

## Patio Pro Model# 1515



**TO ORDER**  
 Visit our online store at:  
**www.chargriller.com**  
 or  
**CALL: 912-638-4724**  
 or  
**FAX: 912-638-2580**  
 or **MAIL:**  
**P.O. Box 30864**  
**Sea Island, GA**  
**31561**

• **Cover**

- Custom Fit, Weather Resistant
- Protects grill finish
- Grill cover #6060.....



\$14.99

• **Apron**

- Machine Washable
- Two Front Pockets
- Adjustable Straps.....



\$14.99



-----

Name \_\_\_\_\_ Telephone \_\_\_\_\_

Street Address \_\_\_\_\_

City / State / Zip \_\_\_\_\_

Email \_\_\_\_\_

Please bill my credit card:    

Check or Money Order (Sorry—No C.O.D.s)  
 Check orders will be held 2 weeks before shipment

EXPIRATION DATE

**PLEASE VISIT OUR WEB SITE FOR SHIPPING COSTS**  
**www.CharGriller.com**  
**Model# 1515 Patio Pro**

Prices & policies subject to change  
 15% Restocking Fee on all returns  
 No Returns on Used Product.  
 Please Call For updated Pricing  
 and Product Availability.

Georgia Customers add a 7% sales tax.  
 Washington state Customers add a 10% sales tax

Qty.	Product	Price
	Adjustable Fit Apron	\$14.99
	Cover For Grill	\$14.99
	Shipping Charge	
	Total	



**P.O. Box 30864  
Sea Island, GA  
31561  
912-638-4724  
www.CharGriller.com**

#### **Warranty Information — Charcoal Grill**

Char-Griller® will repair or replace any defective part of its grillers/smokers for a period of up to one year from the date of purchase. Char-Griller® will also repair or replace the body (bottom half) of its grillers/smokers if the metal is rusted through or burned through for a period up to five years. Char-Griller will repair or replace any defective part of its side fire boxes for a period up to one year from the date of purchase.

Proof of purchase, proof of purchase date, photo and prepaid return of the item in question may be required. Misuse, abuse, or commercial use nullifies all warranties. Paint/finish is not warranted. Products are not warranted against rust.

The warranty is for replacement of defective parts only. Manufacture will not be responsible for damage resulting from accident, alteration, misuse, abuse, hostile environments, improper installation, installation not in accordance with local codes of service of unit.

This limited warranty does not cover any scratches, dents, corrosion or discoloring by heat, abrasive and chemical cleaners nor any components used in the installation of the appliance.

**Save your receipt for all warranty claims.**