

## USE AND CARE GUIDE

---

### LED FLUSHMOUNT

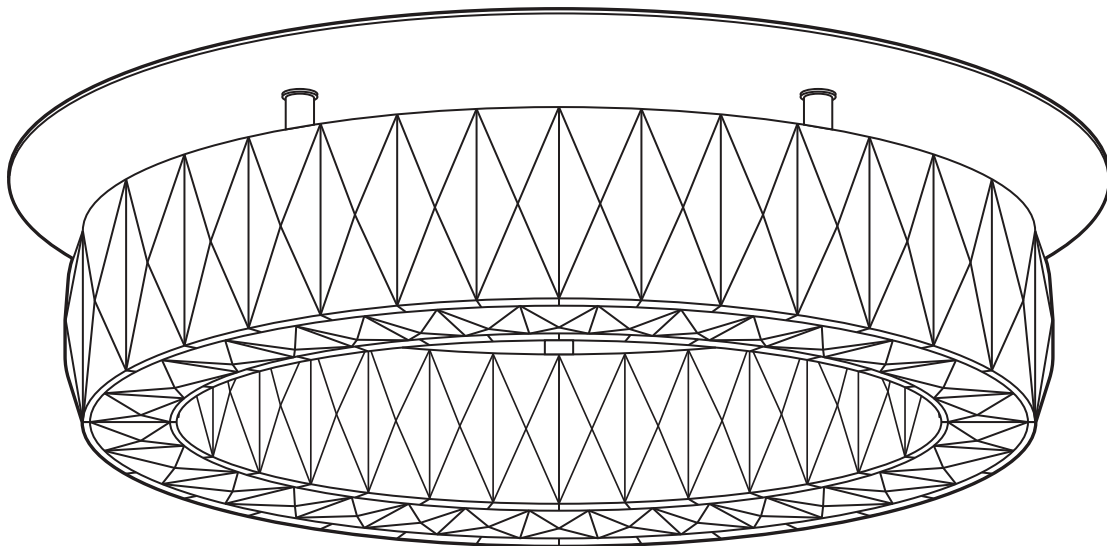

Questions, problems, missing parts? Before returning to the store,  
call Home Decorators Collection Customer Service.  
8 a.m. - 7 p.m., EST, Monday-Friday, 9 a.m. - 6 p.m., EST, Saturday

**1-800-986-3460**

**[HOMEDEPOT.COM/HOMEDECORATORS](http://HOMEDEPOT.COM/HOMEDECORATORS)**

---

### THANK YOU

We appreciate the trust and confidence you have placed in Home Decorators Collection through the purchase of this light fixture. We strive to continually create quality products designed to enhance your home. Visit us online to see our full line of products available for your home improvement needs. Thank you for choosing Home Decorators Collection!

# Table of Contents

Table of Contents.....	2	Hardware Included.....	3
Safety Information.....	2	Package Contents.....	4
Warranty.....	2	Installation .....	5
Pre-Installation .....	3	Operation .....	6
Planning Installation.....	3	Care and Cleaning .....	6
Tools Required.....	3	Troubleshooting.....	6

# Safety Information

- Consult a qualified electrician if you have any electrical questions.
- Any changes or modifications not expressly approved by the party responsible for compliance could void the user's authority to operate the equipment.
- NOTE:** This equipment has been tested and found to comply with the limits for a Class B digital device, pursuant to part 15 of the FCC Rules. These limits are designed to provide reasonable protection against harmful interference in a residential installation. This equipment generates, uses and can radiate radio frequency energy and, if not installed and used in accordance with the instructions, may cause harmful interference to radio communications. However, there is no guarantee that interference will not occur in a particular installation. If this equipment does cause harmful interference to radio or television reception, which can be determined by turning the equipment off and on, the user is encouraged to try to correct the interference by one or more of the following measures:
  - Reorient or relocate the receiving antenna.
  - Increase the separation between the equipment and receiver.
  - Connect the equipment into an outlet on a circuit different from that to which the receiver is connected.
  - Consult the dealer or an experienced radio/TV technician for help.



**CAUTION:** Inspect the wire insulation for any cuts, abrasions, or exposed copper that may have resulted during shipping. If there is a defect in the wire, do not attempt installation. Please call our Customer Service Team at 1-800-986-3460.



**WARNING:** Before starting installation of this fixture or removal of a previous fixture, disconnect the power by turning off the circuit breaker or by removing the fuse at the fuse box.



**WARNING:** Risk of electrical shock. Do not open the crystal pieces. Should the crystal pieces of the light fixture break, consult a qualified electrician.

# Warranty

The manufacturer warrants this lighting fixture to be free from defects in materials and workmanship for a period of three (3) years from date of purchase. This warranty applies only to the original consumer purchaser and only to products used in normal use and service. If this product is found to be defective, the manufacturer's only obligation, and your exclusive remedy, is the repair or replacement of the product at the manufacturer's discretion, provided that the product has not been damaged through misuse, abuse, accident, modifications, alterations, neglect, or mishandling. This warranty shall not apply to any product that is found to have been improperly installed, set-up, or used in any way not in accordance with the instructions supplied with the product. This warranty shall not apply to a failure of the product as a result of an accident, misuse, abuse, negligence, alteration, faulty installation, or any other failure not relating to faulty material or workmanship. This warranty shall not apply to the finish on any portion of the product, such as surface and/or weathering, as this is considered normal wear and tear. The manufacturer does not warrant and specifically disclaims any warranty, whether express or implied, of fitness for a particular purpose, other than the warranty contained herein. The manufacturer specifically disclaims any liability and shall not be liable for any consequential or incidental loss or damage, including but not limited to any labor / expense costs involved in the replacement or repair of said product.

Contact the Customer Service Team at 1-800-986-3460 or visit [www.homedepot.com/homedecorators](http://www.homedepot.com/homedecorators).

# Pre-Installation

## PLANNING INSTALLATION

- Read all instructions before installation.
- To avoid damaging this product, assemble it on a soft, non-abrasive surface, such as carpet or cardboard.
- Keep your receipt and these instructions for proof of purchase.

## TOOLS REQUIRED

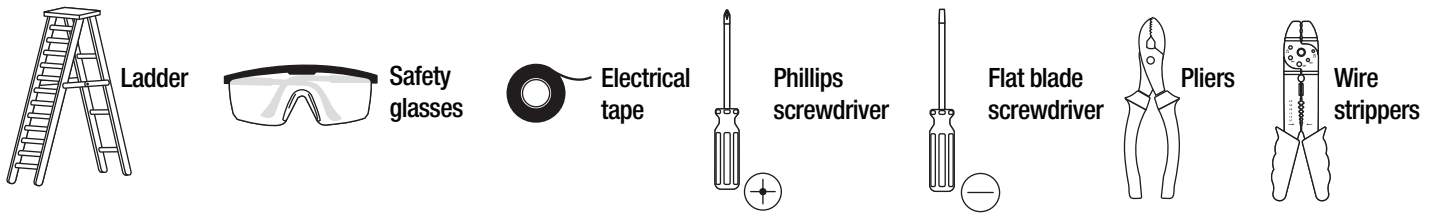

## HARDWARE INCLUDED



**NOTE:** Hardware not shown to actual size.

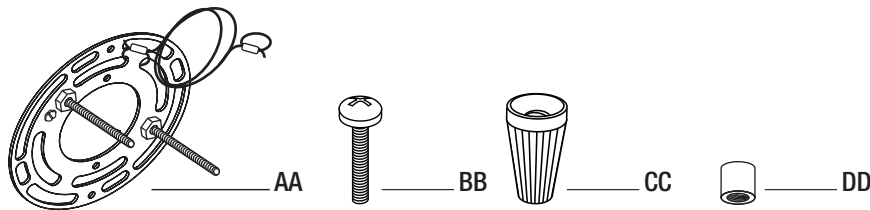

Part	Description	Quantity
AA	Mounting unit (preinstalled w/ safety cable)	1
BB	Mounting screw	2
CC	Wire nut	3
DD	Cap nut (preinstalled)	2

# Pre-Installation (continued)

## PACKAGE CONTENTS

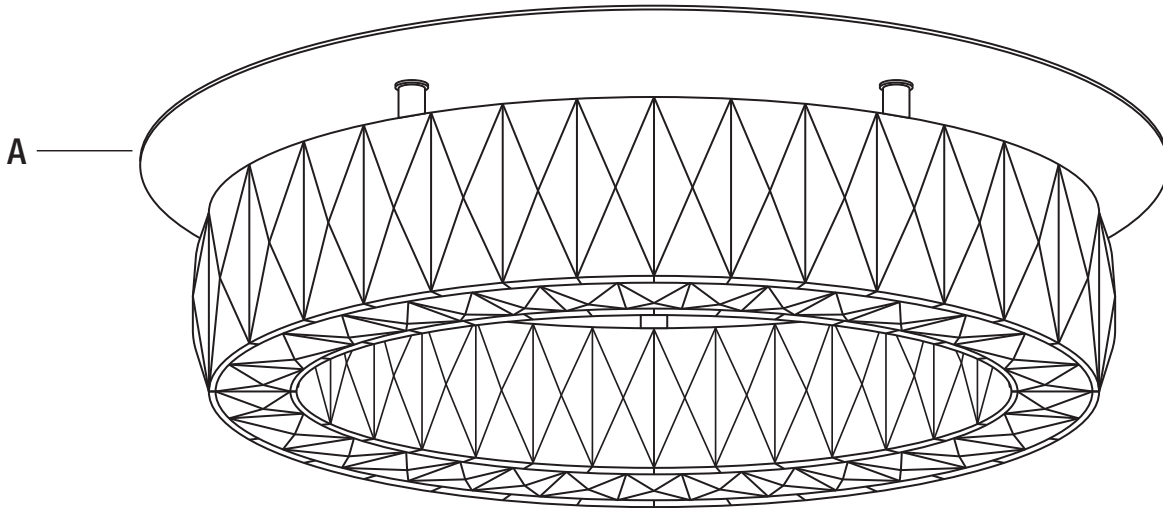

Part	Description	Quantity
A	Light fixture	1

# Installation

## 1 Attaching the mounting unit to the junction box

- Remove the pre-installed cap nuts (DD) from the mounting unit (AA) and put them in a safe location. Attach the mounting unit (AA) to the junction box (not included) with the mounting screws (BB).

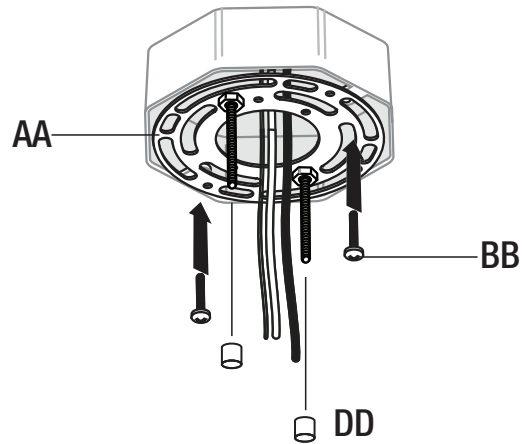

**NOTE:** The pre-installed support screws on the mounting unit (AA) should protrude out away from the junction box.

## 2 Making the electrical connections

- Connect the copper wire from the light fixture (A) to the mounting unit by securing it with the preinstalled ground screw.
- Connect the black to black (power), the white to white (neutral) and copper wire to ground wire with the wire nuts (CC) and secure with electrical tape (not included).

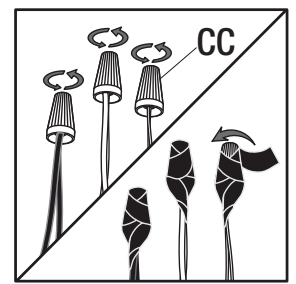
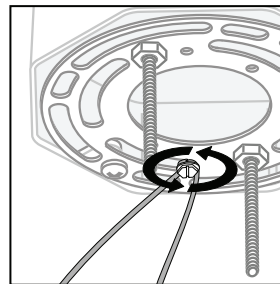

**NOTE:** If the wires from the fixture are the same color, attach the side with markings or letters to the black (positive) wire and the other to the white (neutral) wire.

## 3 Installing the light fixture

- Secure the light fixture (A) to the junction box by placing it over the preinstalled support screws on the mounting unit (AA) and secure with the cap nuts (DD).

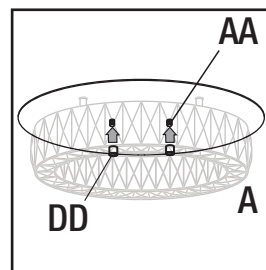

**NOTE:** Risk of electrical shock, do not open the crystal pieces. Should the crystal pieces of the light fixture break, consult a qualified electrician.



**NOTE:** When installing the light fixture be careful of protruding clips along the crystal pieces.

## Operation

### 1 Turning the light on

- Turn the light switch on to activate the fixture.

## Care and Cleaning

- Clean the lamp with a soft, dry cloth.
- Do not use any cleaners with chemicals, solvents, or harsh abrasives.
- When cleaning the light fixture be careful of protruding clips along the crystal pieces..

## Troubleshooting

Problem	Possible Cause	Solution
The bulb will not light.	The power is off.	Ensure the power supply is On.
	There is a faulty wire connection.	Check the wiring.
	The circuit breaker is off.	Ensure the circuit breaker is in the On position.
The fuse blows or circuit breaker trips when the light is turned on.	There are crossed wires or the power wire is grounding out.	Check the wire connections. Contact a qualified electrician or call the Customer Service Team at 1-800-986-3460.

**HOME**  
**DECORATORS**  
**C O L L E C T I O N**

Questions, problems, missing parts? Before returning to the store,  
call Home Decorators Collection Customer Service.  
8 a.m. - 7 p.m., EST, Monday-Friday, 9 a.m. - 6 p.m., EST, Saturday

**1-800-986-3460**

**[HOMEDEPOT.COM/HOMEDECORATORS](http://HOMEDEPOT.COM/HOMEDECORATORS)**

Retain this manual for future use.