

CATSKILL

C R A F T S M E N , I N C.



Model 7225

GENERAL:

1. You have purchased model 7225. Overall dimensions of an assembled unit is 20 3/4" x 21" x 35 1/2" when drop leaves are down.

2. Should you need assistance or need to replace a damaged or missing part, DO NOT RETURN THE UNIT TO THE STORE where you purchased it, simply give us a call at 607-652-7321 from 7:30 - 4:00 PM Eastern time and we'll send you the prepaid part via UPS usually that same day!

3. Read the assembly instructions and the enclosed brochure before beginning assembly. Assembly is very easy if you read and follow the instructions step by step.

4. Tools required: Phillips screwdrivers, medium and small; medium flat blade screwdriver, pliers and a hammer.

CABINET PARTS

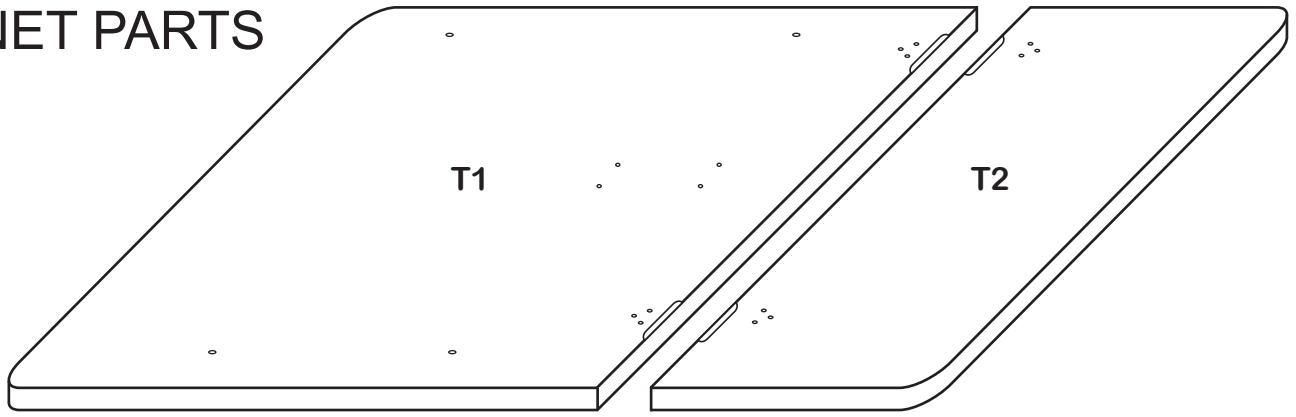

Cart Top P/N TT-7225 (1)

Drop Leaf P/N DL-7225 (1)

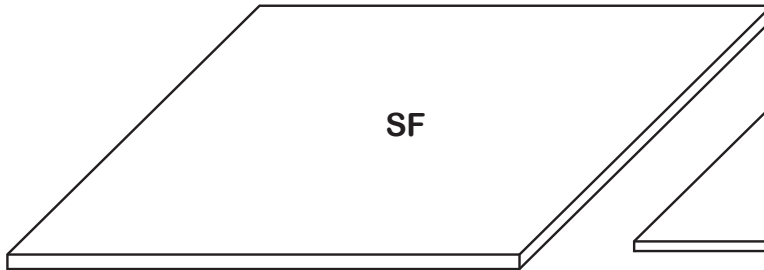

Bottom Shelf P/N BS-7225 (1)



Drawer Bottom P/N DB-7225 (1)

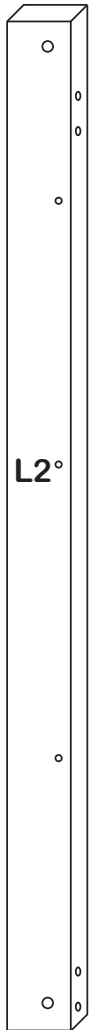

Left Leg
P/N L7225L

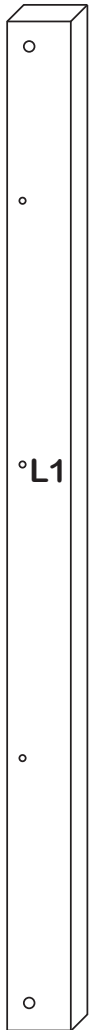

Right Leg
P/N R7225R



Drawer Front P/N DF-7225 (1)

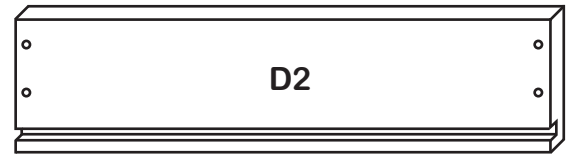

Drawer Back P/N DBK-7225 (1)

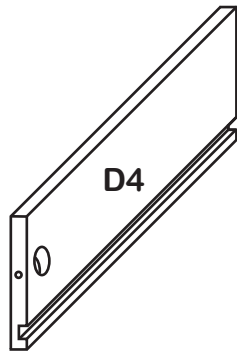

Drawer Side/Right P/N DS-7225/R

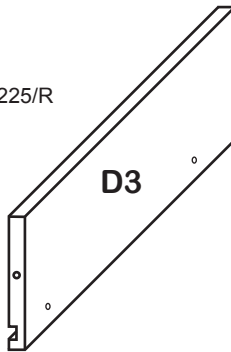

Drawer Side/Left P/N DS-7225/L

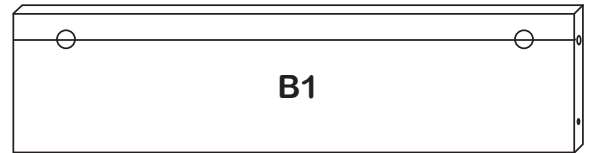

Top Back Brace P/N B-15 7/8-5 3/4-TB (1)

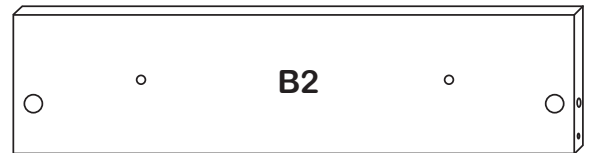

Top Left Brace P/N B-15 7/8-5 3/4-TS-7225 (1)

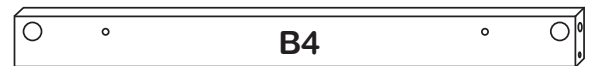

Bottom Front Brace P/N B-15 7/8-BF-BB-7225 (2)

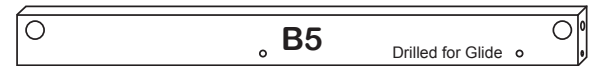

Top Right Side Brace P/N B-15 7/8-TRS-7225 (3)

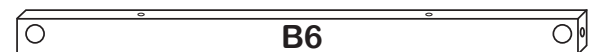

Top Front Brace P/N B-15 7/8-1 1/4-TF (1)





Basket Rails P/N BR-17-1 1/8-7225 (6)

HARDWARE

 
1 3/4" Phillips Flat Head Bolt (8)

 
1 3/4" Phillips Flat Head #8 Screw (2)

 
1 1/4" Phillips Flat Head #8 Screw (18)

 
5/8" Phillips Flat Head #8 Screw (18)

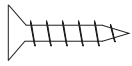
  (Used on Cabinet Side Glides)
5/8" Phillips Flat Head #7 Screw (4)

  (Used on Drawer Side Glides)
5/8" Phillips Flat Head #5 Screw (4)

 
3/4" Truss Head Machine Screw (2)

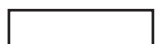

1" Long 3/16" DIA. Steel Pin (4)

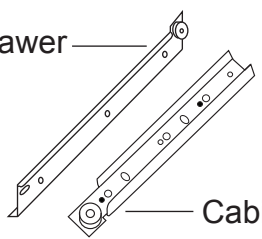

3/4" Long 3/16" DIA. Steel Pin (14)

Drawer ————— Cabinet
Drawer Glide (2 Sets)

The glides look almost alike however, the right glide (as you face the cart) has a rolled lip at the top of the glide that keeps the drawer glide wheel in place.

"Z" Bracket (2)

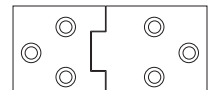
10-24 Hex Nut (8)

Hinge (2)

5/8" Wooden Disk (8)

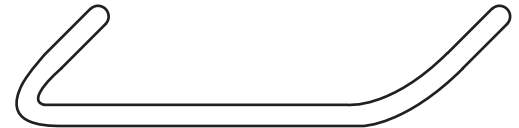

Handle (1)

P/N Drop Leaf Support (1)



Bastion Post (10)

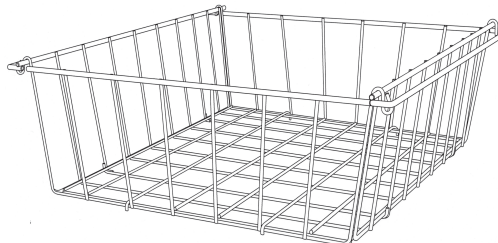

Bastion Set Screw (10)

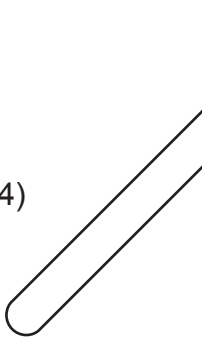

Bastion Barrel Nut (10)

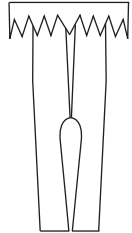

Wire Baskets (3)

Towel Bar Post (2)

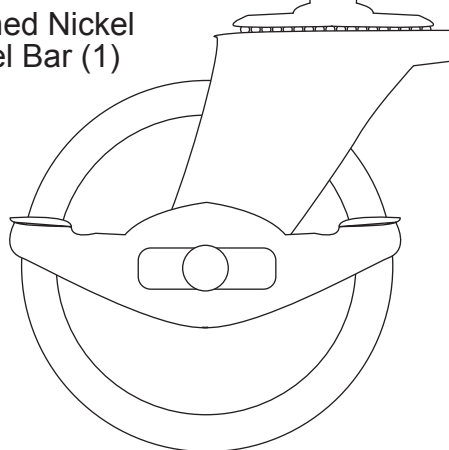
Polished Nickel Towel Bar (1)

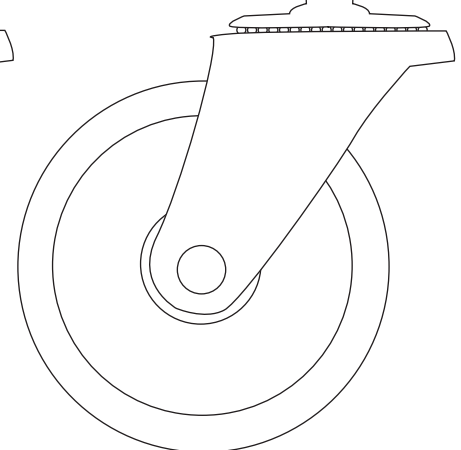

Caster Socket (4)

Locking Wheel Casters (2)

Wheel Casters (2)

STEP 1

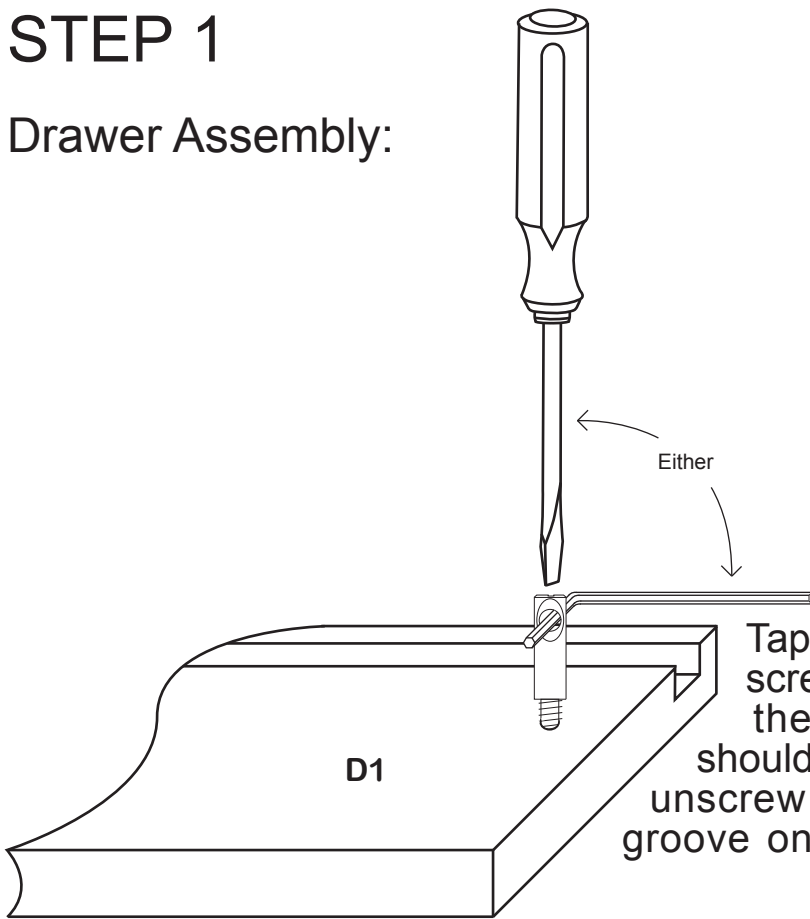
Drawer Assembly:



Tap in post with a hammer to start and screw down with a screwdriver or with the included allen wrench until the shoulder of the post hits the wood. Then unscrew until the hole is parallel with the groove on the bottom of the Drawer Front.

To understand how the bastion fastening system works see next page.

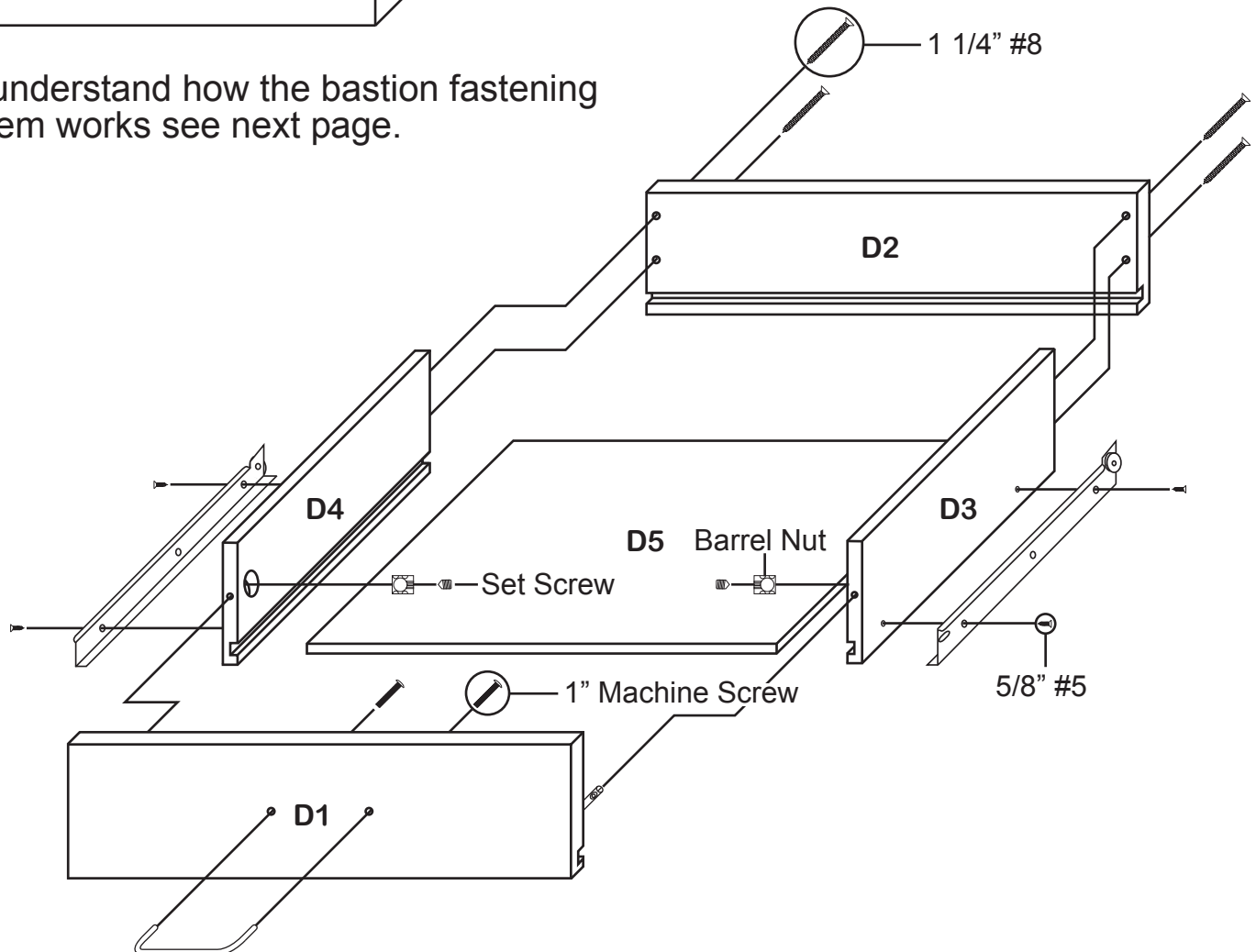

TIPS ON HOW THE BASTION FASTENING SYSTEM WORKS

1. The Bastion fastening system consists of a steel post (threaded on one end with a hole through the shaft on the other end); a Barrel Nut (cylindrical barrel-shaped with threaded open end & holes through the sides); and a Set Screw (Phillips slot on one end, pointed on the other)

2. To attach Posts: A) Dip threads of Post in vegetable oil. B) Align threaded end of Post with hole in wood, tap on slotted end with hard hammer until threads enter, then tighten down using a flat head screw driver or the provided allen wrench (See the Illus. Bas. 3 for alternate seating methods). **DO NOT TRY TO HAMMER THE POST ALL THE WAY IN AS IT WILL STRIP THE POST HOLE.** C) When solid shaft of Post hits wood, back out approximately 1/2 turn until the hole in the posts is properly aligned as per step by step directions. For example: the holes in the posts on the inside of the drawer front will be parallel with the long length of the drawer front when properly seated.

3. A) Place a Barrel Nut into the nut access hole, so that the threads in the nut face out. The small notches on either side of the nut opening, indicate the location of the holes through the sides of the nut. B) Insert the posts through the end of the braces (or drawer sides); through the holes in the sides of the nut. When properly aligned, you will see the hole in the post inside the barrel nut. Post hole should be slightly off-center toward the wood.

4. Insert the Set Screw into the threaded end of the nut and tighten down. The tip of the Set Screw will seek the center of the hole in the Post as it is tightened down, forcing the Nut toward the main shaft of the Post. This is what tightens the wooden parts together. Set screws should thread easily – **DON'T CROSS THREAD!** If Set Screw doesn't thread easily, check position of the hole in Post.

5. If the wooden parts are not tight against each other, the Post needs to be screwed a half turn at a time until wood joints are tight.

Illustration Bas. 1

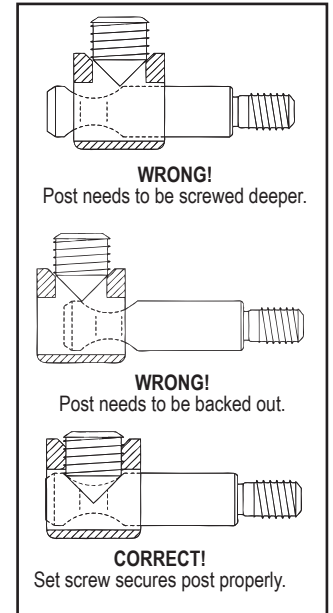

Step 1

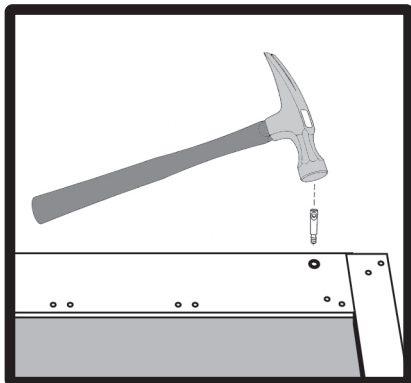
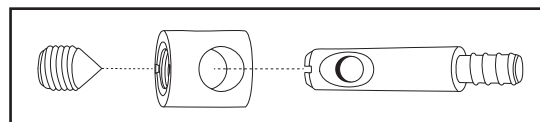
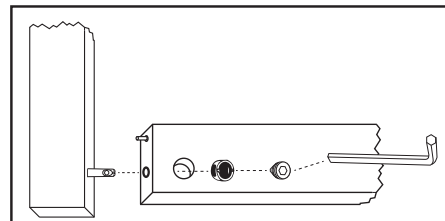

Illustration Bas. 2



Step 2



Allen Wrench Provided

Illustration Bas. 3

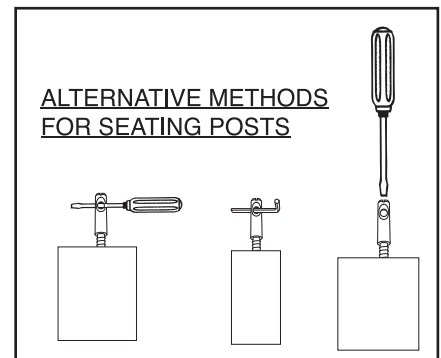

See video on our website!

If you have any questions regarding assembly or missing or damage parts, call our customer support number:

607-652-7321 or 888-732-7321.

Customer Support Hours are 8am-5pm Mon. - Fri. Eastern Time zone.

STEP 2

Top Assembly:

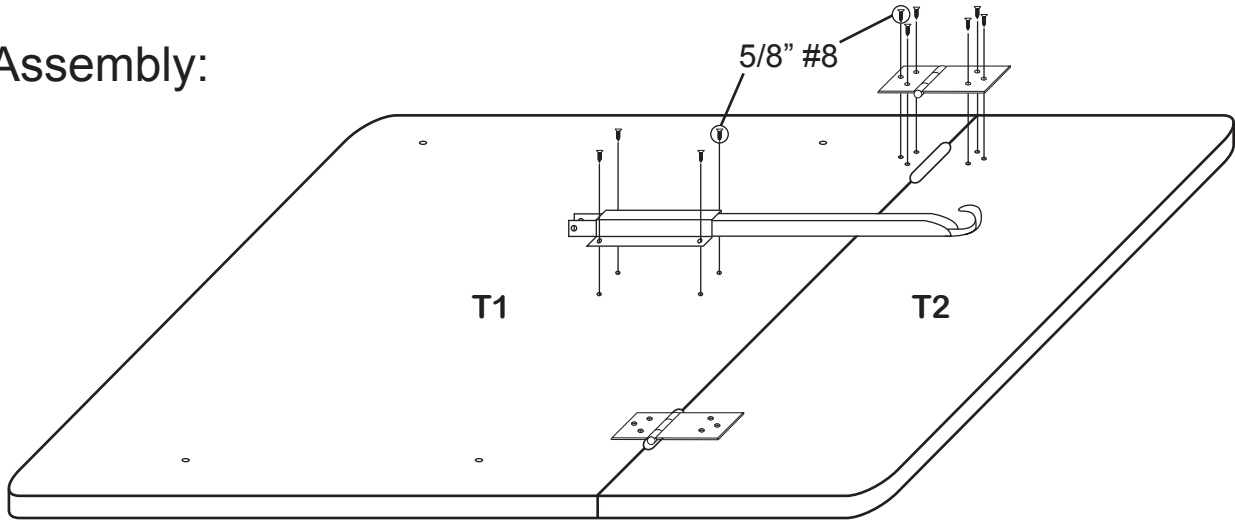

STEP 3

Brace Preparation:

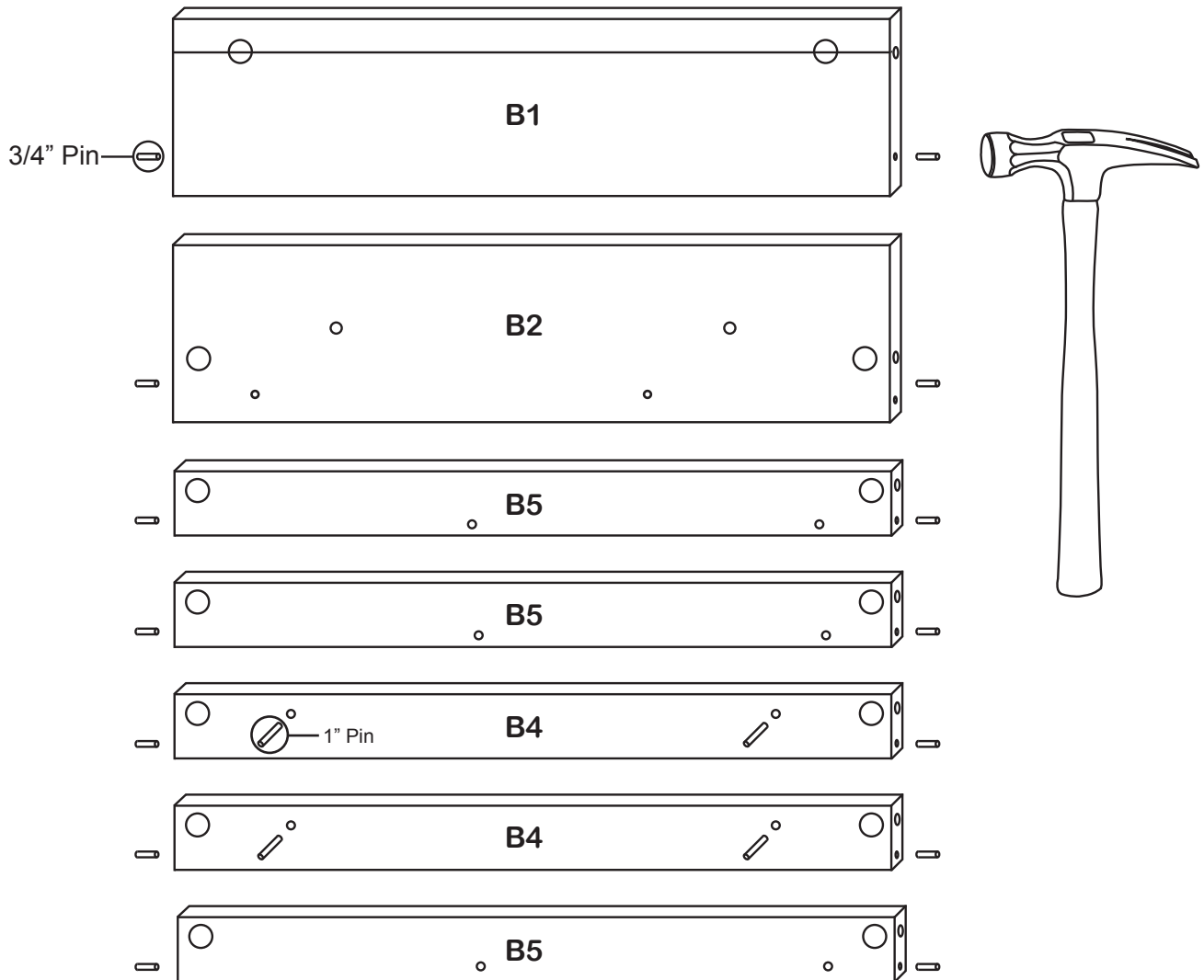

STEP 4

Left Side Assembly:

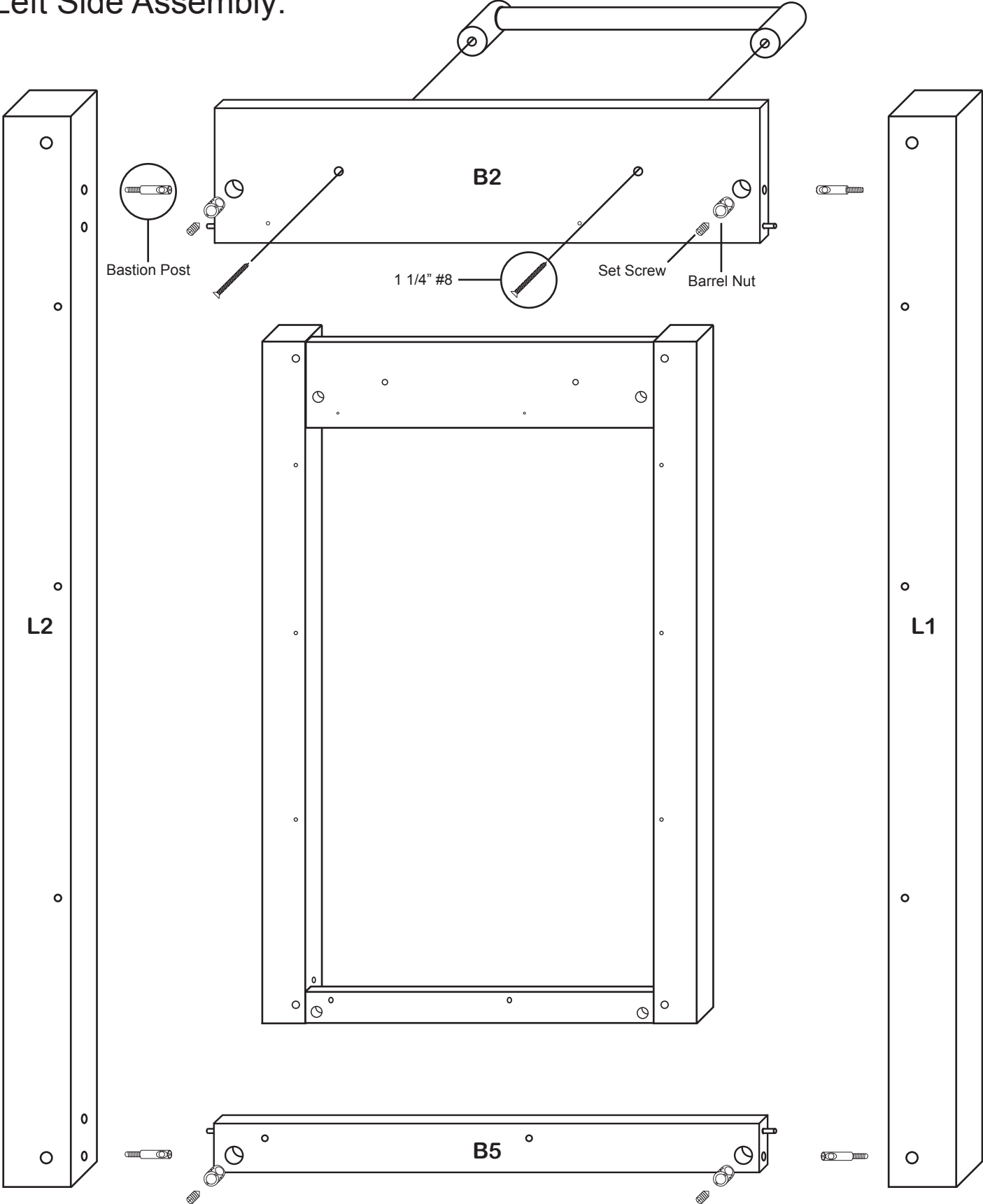

STEP 5

Right Side Assembly:

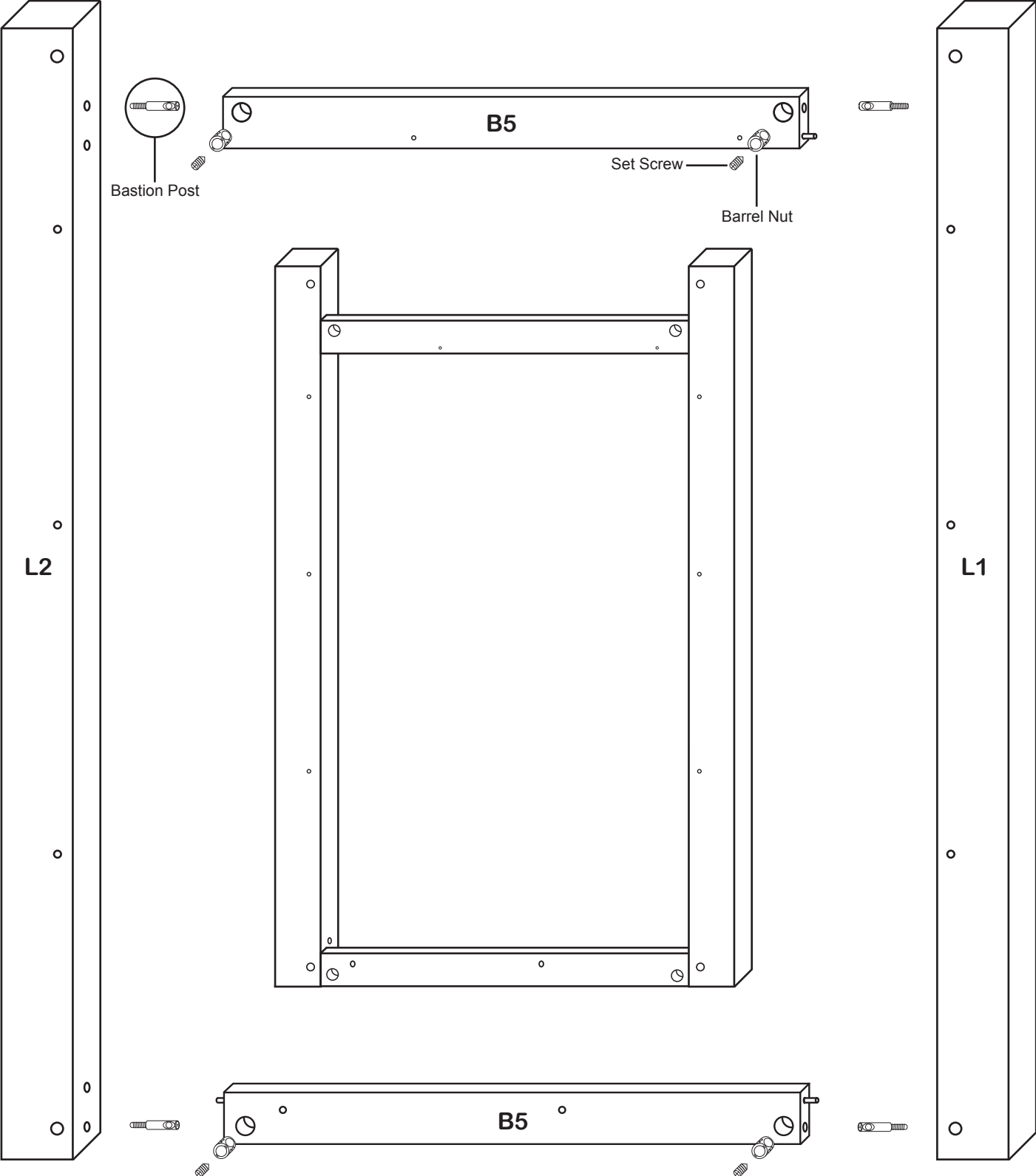

STEP 6

Basket Rail Assembly:

The glides look almost alike however, they are labeled CR for cabinet right and CL for cabinet left.

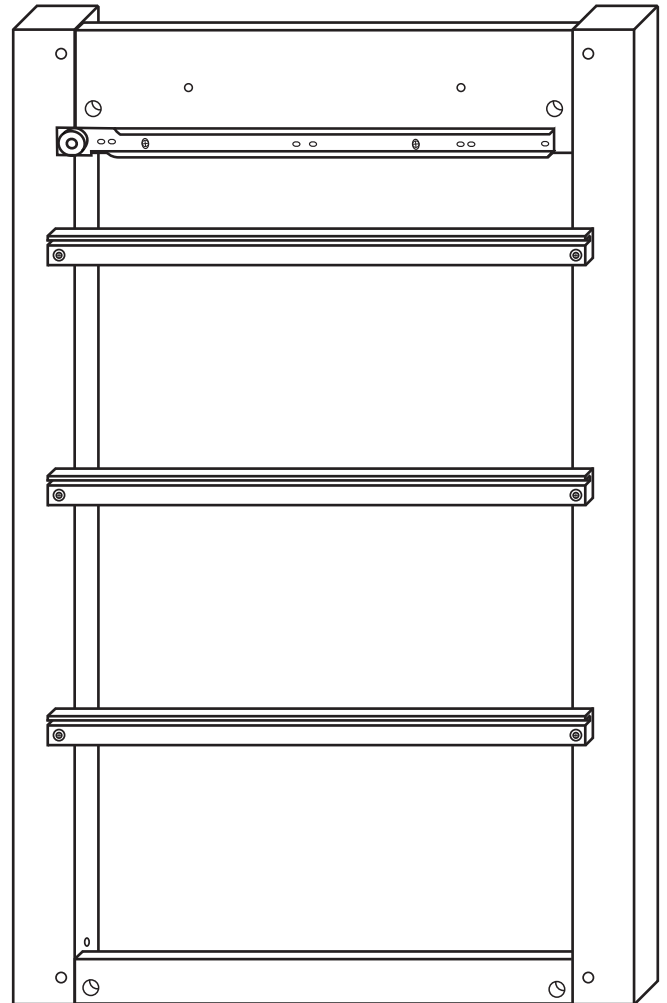
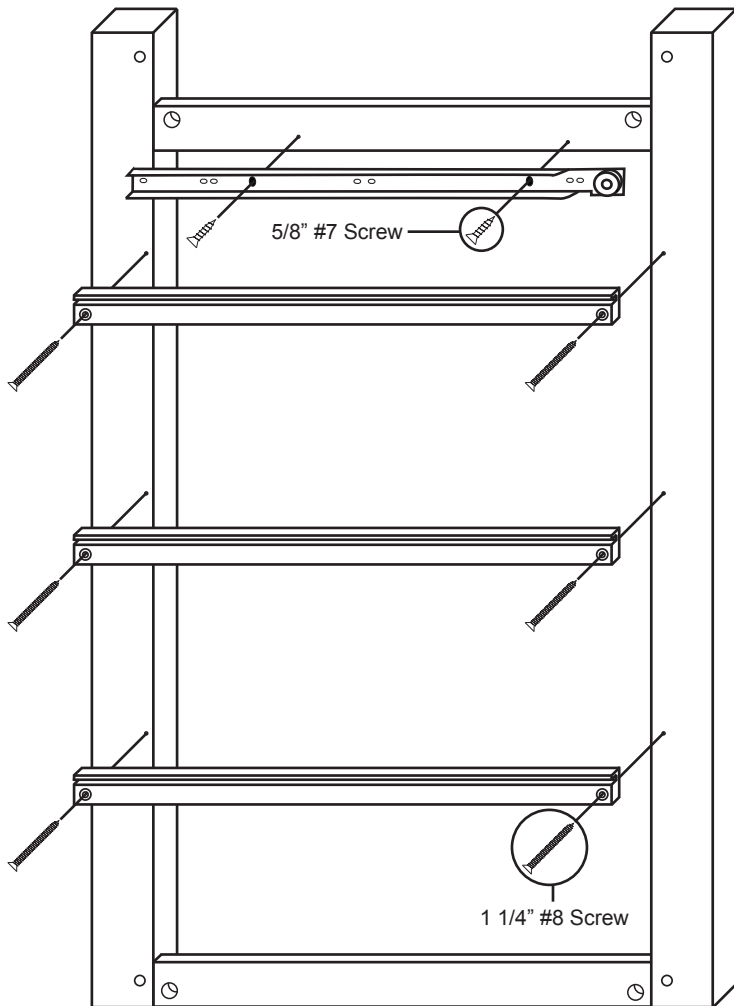

STEP 7

Back Assembly:

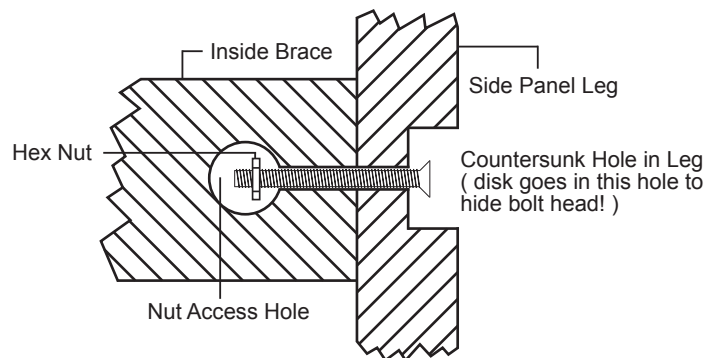
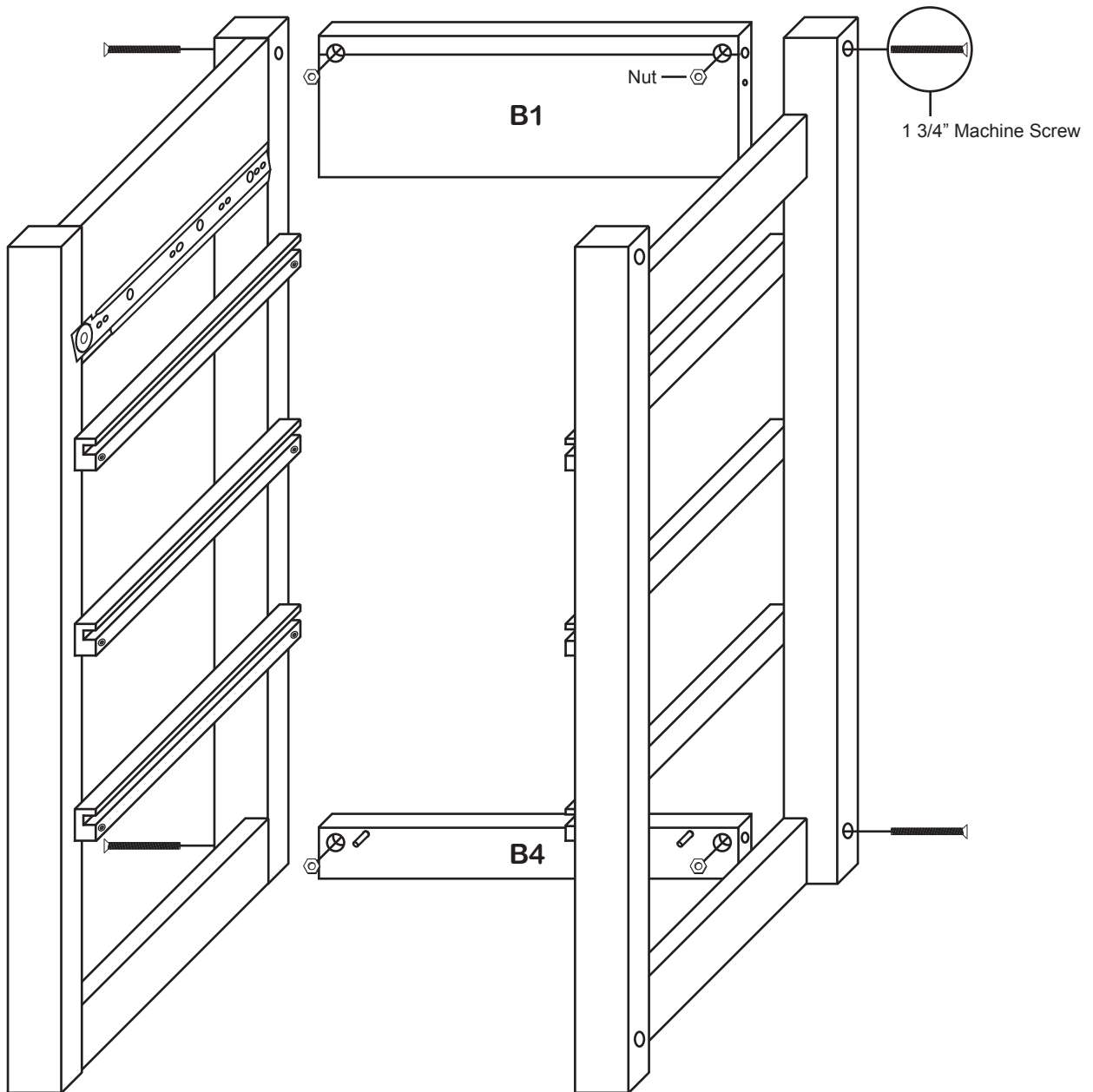

STEP 8

Front Assembly:

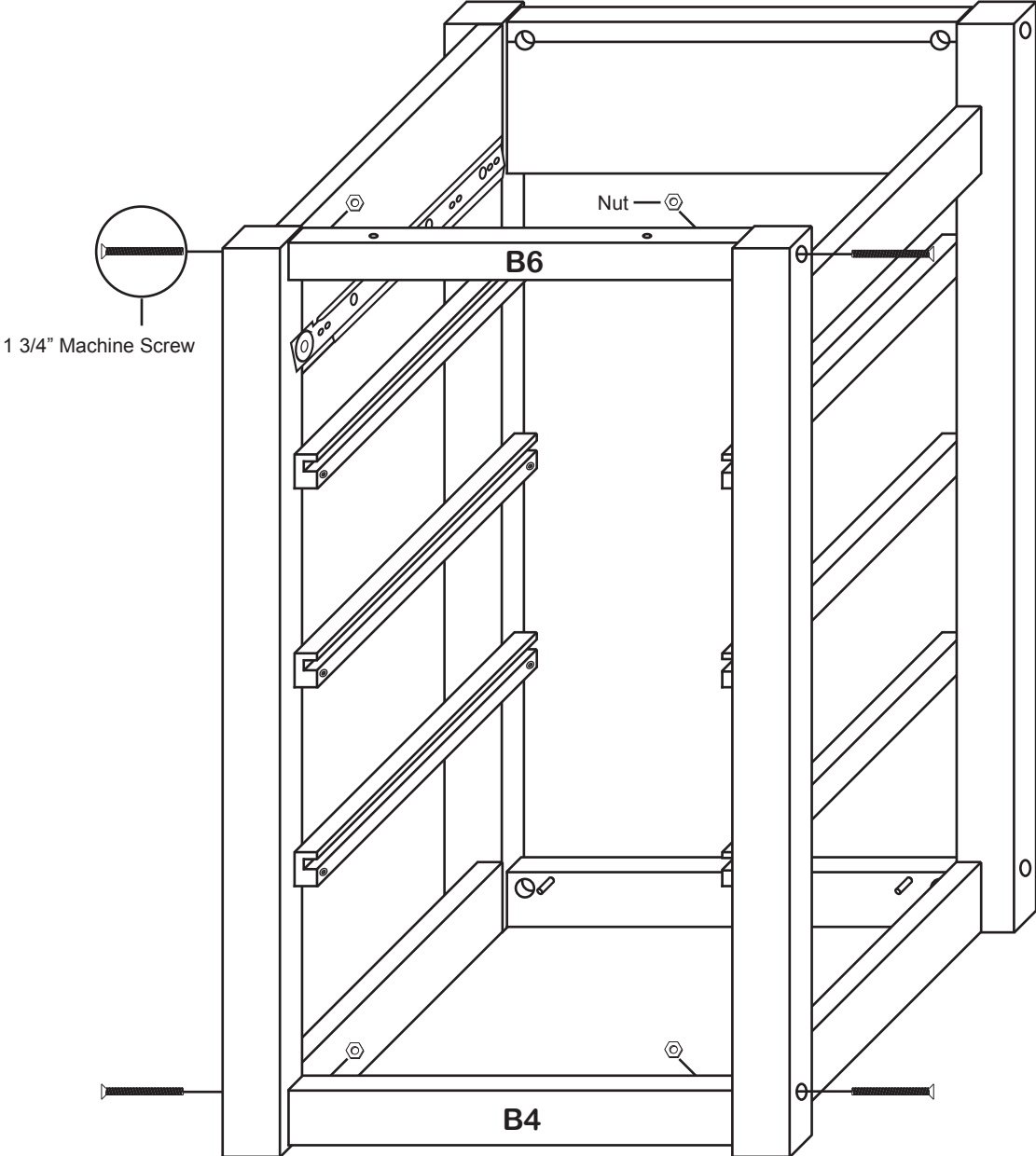

STEP 9

Top Attachment:

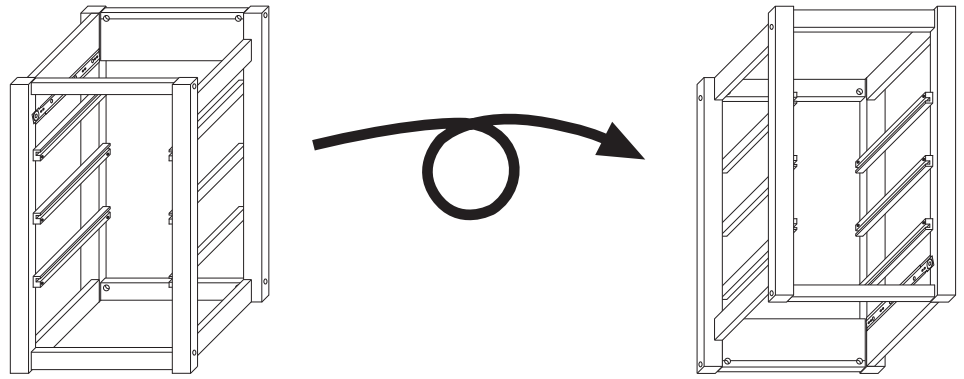

Invert the Cart Base and position onto the Cart top. Fit the "Z" brackets into the slot across the top back brace. Align the holes in the top front brace with the pilot holes at the front of the cart top. Attach the top front brace to the cart top with 1-3/4" #8 Wood Screws. Tighten the "Z" brackets to complete top attachment with 5/8" #8 screw.

NOTE: The holes for the "Z" brackets are further apart than those for the Top Back Brace

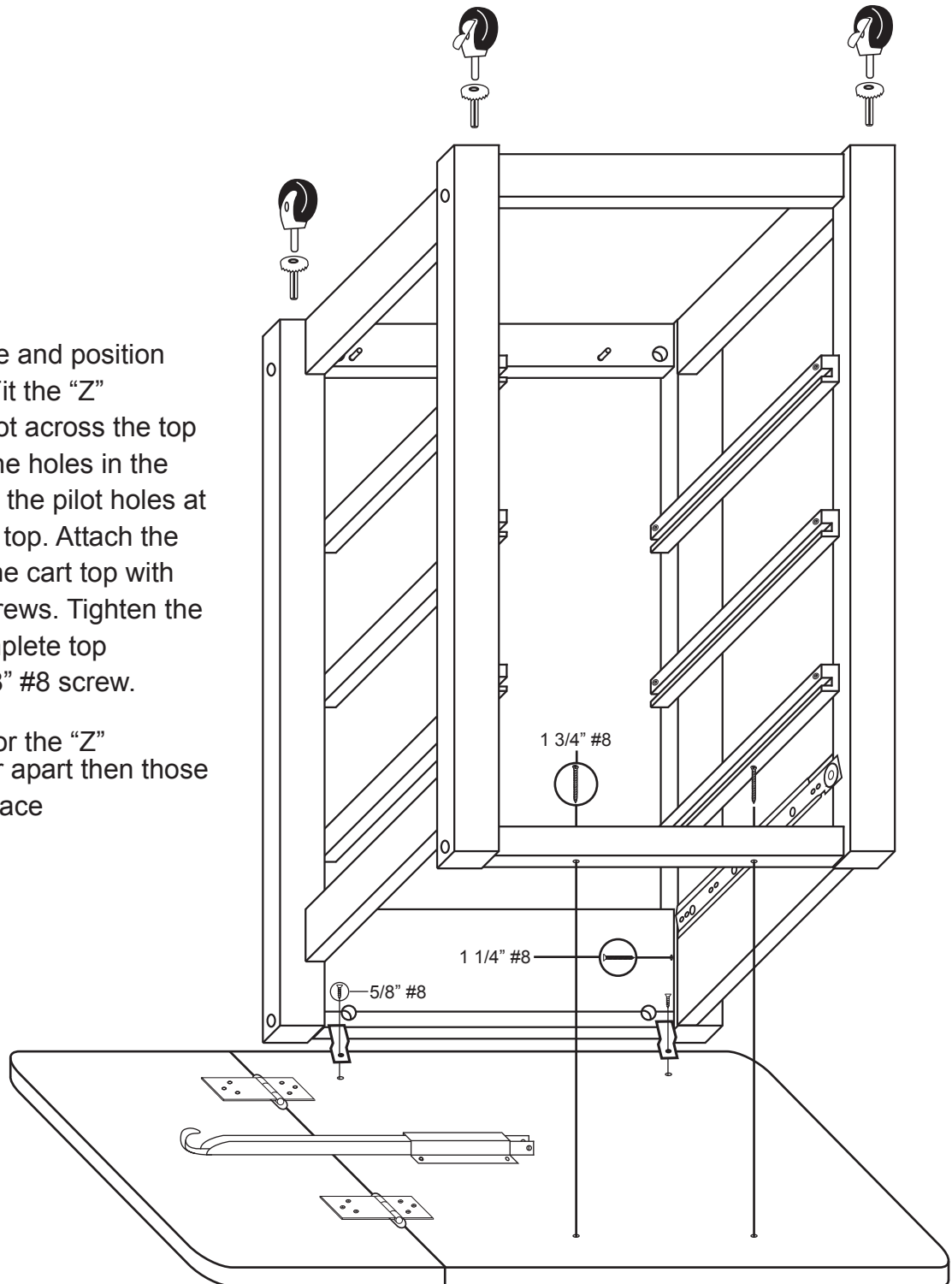

STEP 10

Main Assembly:

After you assemble the baskets using given instructions it may be necessary to pinch the ends with pliers to hold them together.

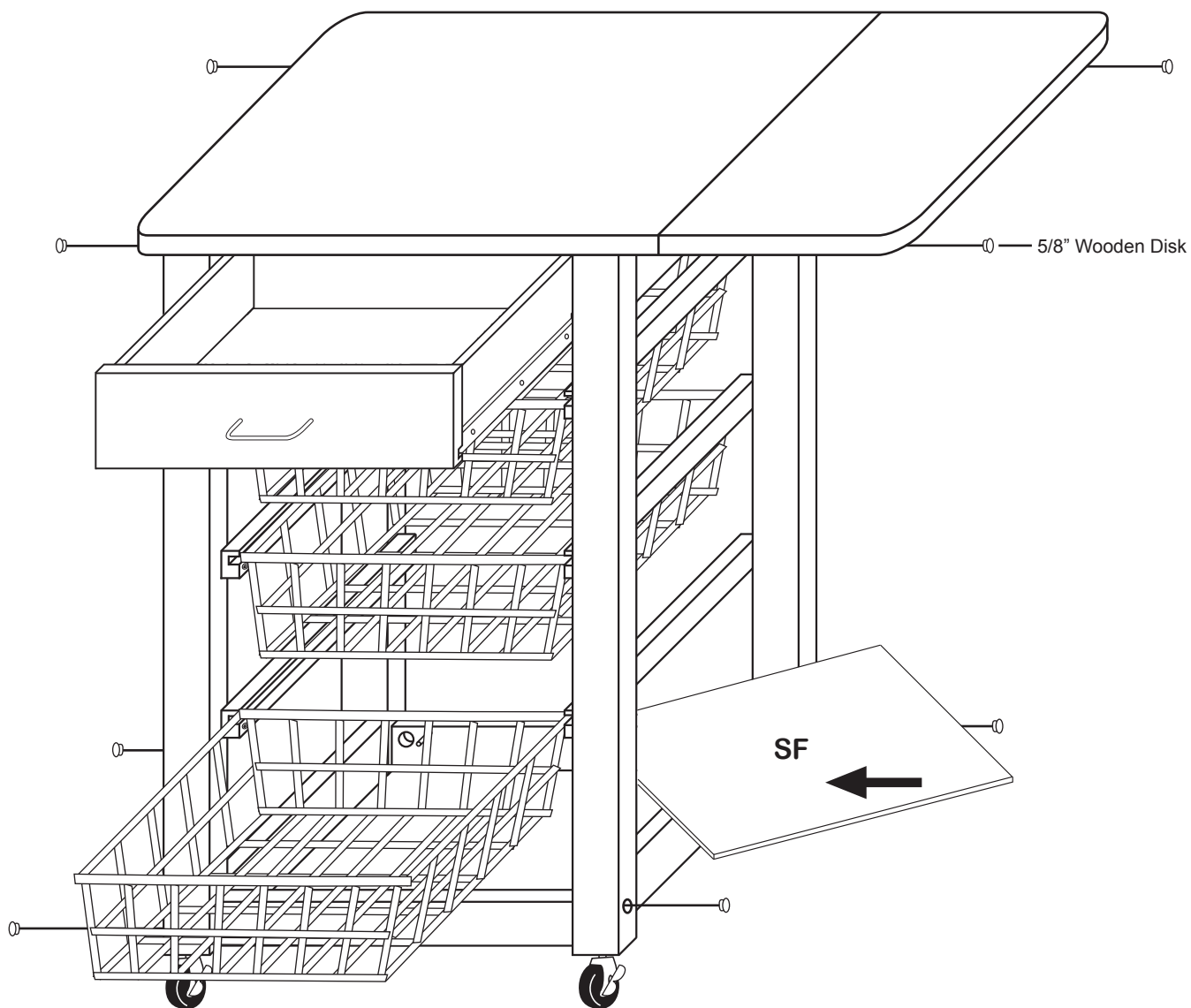



For continued beauty and long life of your Catskill Craftsmen cart, we recommend Catskill Craftsmen's Butcher Block Oil.

If you would like to purchase Butcher Block Oil directly from Catskill Craftsmen's factory, we offer a reduced price. For one eight ounce (8 fl. oz.) bottle, which is sufficient for two applications, simply send \$6.95 along with the completed coupon to the address below. Visit us online at www.catskillcraftsmen.com to browse our assortment of butcher block care products. Visa and Mastercard are accepted online.



Catskill Craftsmen, Inc.
15 West End Ave.
Stamford, NY 12167-1296

CATSKILL
CRAFTSMEN, INC.

BUTCHER BLOCK OIL COUPON

Please send me _____ # of bottle(s) of the
Catskill Craftsmen Butcher Block Oil at \$6.95.
My Check or Money Order is enclosed for a
total of \$ _____.
Item Code: 7225

NAME _____

ADDRESS _____

CITY _____

STATE _____ ZIP _____

Please make checks payable to: Catskill Craftsmen Inc.
15 West End Ave. Stamford, NY 12167-1296