



CARPET WASHER

Model #'s FD50100
FD50105
FD50110



1·2·3...

MANUAL

#961151127 / ID109742 / R0
©2014 All rights reserved



LET'S GO.™

HI. WELCOME.

Congrats on purchasing your new Dirt Devil® Carpet Washer. Inside, you'll find everything you want to know from the quick start guide to how to.

So what are you waiting for? LET'S GO.™

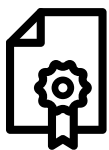

PRODUCT REGISTRATION

Warranty Registration

Be sure to register your product online at www.DirtDevil.com or call 1-800-321-1134 to register by phone.

Hint: Attach your sales receipt to this Owner's manual. Verification of date of purchase may be required for warranty service of your Dirt Devil® product.

For quick reference, please record your product information below.

Model #: _____

Mfg. Code: _____

(Mfg. code located on the back or bottom of product)

Find GENUINE Replacement Parts at www.dirtdevil.com

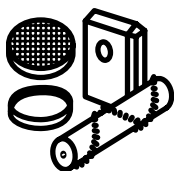

This product uses the following parts:

BELT STYLE _____ 30

PRE-MOTOR FILTER _____ F92

TABLE OF CONTENTS



1·2·3...

Quick Start Assembly _____ 6



Preparing the Carpet _____ 10
How to

- Remove and Replace Clean Water Solution Tank _____ 12
- Empty the Dirty Water Tank _____ 14
- Place Dirty Water Tank in Base of Cleaner _____ 15
- Remove the Brushroll _____ 16
- Replace the Belt _____ 17



Trouble Shooting _____ 18



Limited Warranty _____ 19

WARNING

IMPORTANT: READ CAREFULLY BEFORE ASSEMBLY AND USE. THIS PRODUCT IS INTENDED FOR HOUSEHOLD USE ONLY. IF USED COMMERCIALY WARRANTY IS VOID.

IMPORTANT SAFETY INSTRUCTIONS

When using an electrical appliance, basic precautions should always be followed, including the following:

READ ALL INSTRUCTIONS BEFORE USING THIS APPLIANCE.

WARNING: TO REDUCE THE RISK OF FIRE, ELECTRIC SHOCK OR INJURY:

- Fully assemble before operating.
- Operate cleaner only at voltage specified on data plate on bottom of cleaner.
- Do not leave appliance when plugged in. Unplug from outlet when not in use and before cleaning or servicing.
- Use indoors only.
- Do not immerse. Use only on carpet moistened by cleaning process.
- Use only DIRT DEVIL® cleaning products intended for use with this machine. (See the “Cleaning Products” section of this manual.)
- Do not use a flammable or combustible liquid to clean a floor.
- Do not allow to be used as a toy. Not intended for use by children age 12 and under. Close supervision is necessary when used near children. To avoid injury or damage, keep children away from product, and do not allow children to place fingers or other objects into any openings.
- Use only as described in this manual. Use only manufacturer’s recommended attachments and products.
- Do not use with damaged cord or plug. If appliance is not working as it should, has been dropped, damaged, left outdoors, or dropped into water, take it to a service center prior to continuing use.
- Do not pull or carry by cord, use cord as a handle, close a door on cord, or pull cord around sharp edges or corners. Do not place product on cord. Do not run appliance over cord. Keep cord away from heated surfaces.
- Do not unplug by pulling on cord. To unplug, grasp the plug, not the cord.
- Do not handle plug or appliance with wet hands.
- Do not put any object into openings. Do not use with any opening blocked; keep free of dust, lint, hair, and anything that may reduce air flow.
- Keep hair, loose clothing, fingers, and all parts of body away from openings and moving parts.
- Turn off all controls before unplugging.
- Use extra care when cleaning on stairs. To avoid personal injury or damage, and to prevent the cleaner from falling, always place cleaner at bottom of stairs or on floor. Do not place cleaner on stairs or furniture, as it may result in injury or damage.
- Do not use to pick up flammable or combustible materials, such as gasoline, or fine wood sandings, or use in areas where they may be present.
- Connect to a properly grounded outlet only. See Grounding Instructions.
- Do not pick up anything that is burning or smoking, such as cigarettes, matches, or hot ashes.
- Do not use without tanks or filters in place.
- Do not clean over floor electrical outlets.
- **WARNING:** This product contains chemicals known to the State of California to cause cancer, birth defects or reproductive harm.

WASH HANDS AFTER USING.



CAUTION: TO REDUCE THE RISK OF DAMAGE:

- Avoid picking up hard, sharp objects with this product, as they may cause damage.
 - Store in a dry place. Do not expose machine to freezing temperatures.
 - Do not use sharp objects to clean out hose as they can cause damage.
 - To assist in reducing drying time, be certain the area is well ventilated when using detergents and other cleaners with this machine.
 - To help prevent matting and resoiling, avoid contact with carpets until they are dry. Keep children and pets away from carpets until they are completely dry.
 - Do not store extractor with solution in tanks.
 - With brushes on, do not allow cleaner to sit in one location with brushes on for extended periods of time, as damage to floor can result.
 - **DO NOT USE THIS EXTRACTOR ON HARD FLOORS. USING THIS MACHINE ON HARD FLOORS MAY SCRATCH OR DAMAGE YOUR FLOOR.**
- SAVE THESE INSTRUCTIONS**

GROUNDING INSTRUCTIONS

This appliance must be grounded. If it should malfunction or breakdown, grounding provides a path of least resistance for electric current to reduce the risk of electric shock. This appliance is equipped with a cord having an equipment-grounding conductor (C) and grounding plug (A). The plug must be inserted into an appropriate outlet (B) that is properly installed and grounded in accordance with all local codes and ordinances.

! WARNING !

Improper connection of the equipment-grounding conductor can result in the risk of electric shock. Check with a qualified electrician or service person if you are in doubt as to whether the outlet is properly grounded. Do not modify the plug provided with the appliance - if it will not fit the outlet, have a proper outlet installed by a qualified electrician. This appliance is for use on a nominal 120-volt circuit and has a grounding plug that looks like the plug (A) illustrated in Fig. 1. A temporary adapter (D) may be used to connect this plug to a 2-pole receptacle (E) if a properly grounded outlet is not available (Fig. 2). The temporary adapter should be used only until a properly grounded outlet (B) can be installed by a qualified electrician (Fig. 1). The green colored rigid ear, lug, or the like (F) extending from the adapter must be connected to a permanent ground (G) such as a properly grounded outlet box cover (Fig. 2). Whenever the adapter is used, it must be held in place by a metal screw. NOTE: In Canada, the use of a temporary adapter is not permitted by the Canadian Electrical Code.

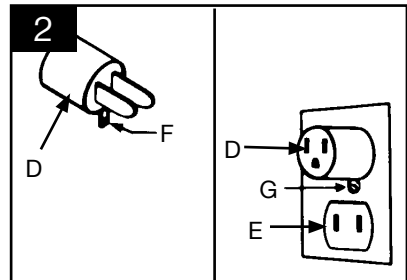
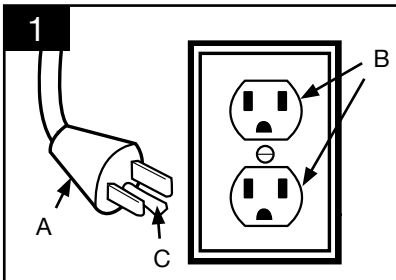

QUICK START

NEED HELP?

Go to dirtdevil.com/support or contact our Customer Service Department at (800) 321-1134 8:00 a.m. - 7:00 p.m. EST Mon. - Fri. or Sat. 10:00 a.m. - 6:00 p.m. EST.

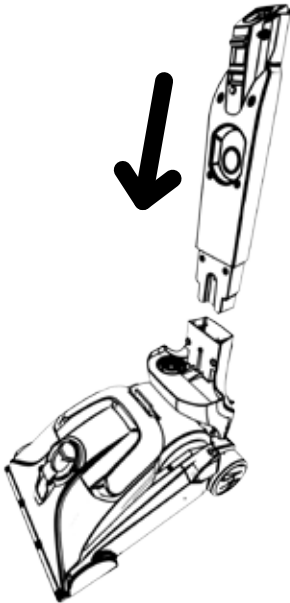

1

POP THE BACK PANEL INTO THE BASE.

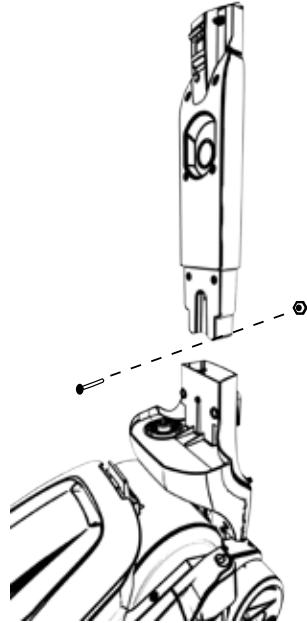

2

SCREW IT TOGETHER.

CHECK FOR COLOR FASTNESS

Before cleaning carpet/upholstery, test for color fastness. Dampen a white cloth with solution. Test a small area in a closet or under a cushion. Gently rub the cloth over the area. Check each color for color bleeding. If the cloth remains clean, it should be safe to clean the carpet/upholstery.

⚠ WARNING

To reduce the risk of fire, electric shock, or injury: ensure the power cord is out of the way before attaching the upper handle.

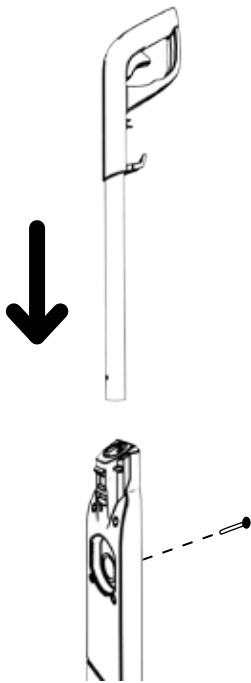
**3**

THEN INSERT THE HANDLE INTO THE BODY. INSERT THE SCREW AND TIGHTEN.

⚠ CAUTION

To reduce the risk of damage: Do not use this extractor on hard floors. Using this machine on hard floors may scratch or damage your floors.

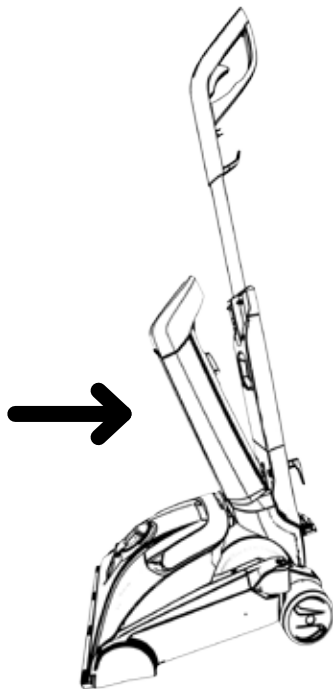
**4**

FILL WATER SOLUTION TANK. (SEE PAGE 12) TIP THE CLEAN WATER SOLUTION TANK IN LIKE THIS. IT WILL CLICK.

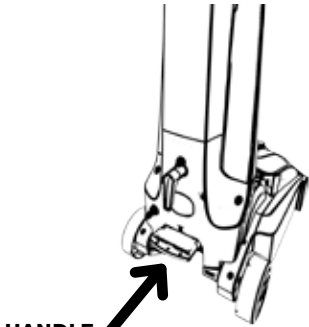

**HANDLE
RELEASE
PEDAL**

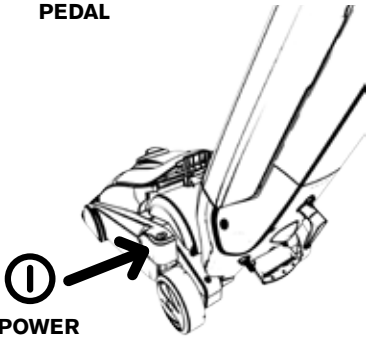

**①
POWER**

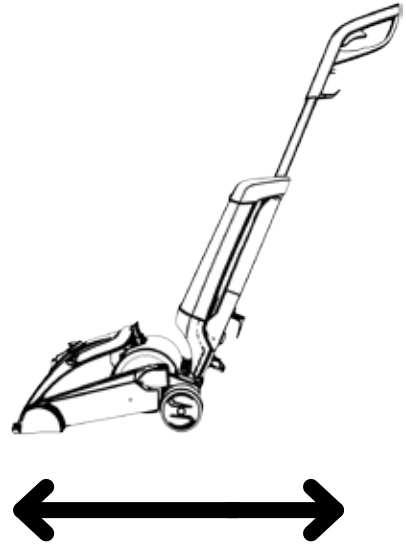

5

PLUG UNIT IN. STEP ON THE HANDLE RELEASE PEDAL AND PULL BACK ON THE UPPER HANDLE. THEN STEP ON THE POWER BUTTON TO TURN ON.

6

PULL TRIGGER TO SPRAY SOLUTION WHILE MOVING FORWARD. THEN SLOWLY RELEASE THE TRIGGER AND PULL YOUR CARPET WASHER BACK TO REMOVE DIRTY WATER AND SOLUTION.

⚠ CAUTION

Never leave unit unattended with power on. Turn OFF when emptying and filling tank. Do NOT oversaturate the carpet. If the sound of the motor changes to a high pitch, this indicates the dirty water tank is full and must be emptied.

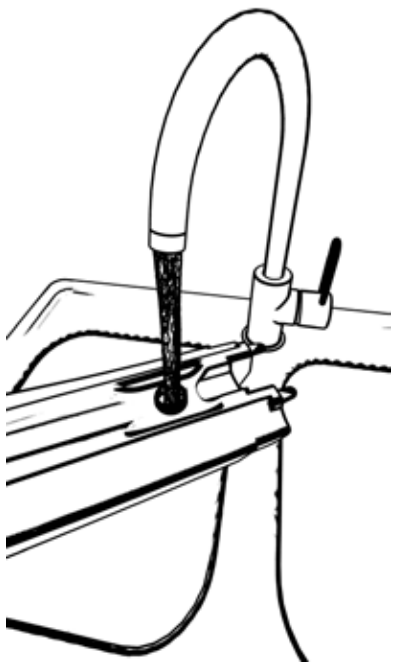

YOUR CARPET IS FRESH AND CLEAN!

LET'S GO.™

7

EMPTY CLEAN WATER SOLUTION TANK AND REFILL WITH CLEAN WATER. REPEAT STEP 6 WITH JUST CLEAN WATER FOR RINSING. EMPTY DIRTY WATER TANK WHEN FULL.



NEED HELP?

Go to dirtdevil.com/support or contact our Customer Service Department at (800) 321-1134
8:00 a.m. - 7:00 p.m. EST Mon. - Fri.
or Sat. 10:00 a.m. - 6:00 p.m. EST.

Pick up the conversation on...



[Facebook.com/DirtDevil](https://www.facebook.com/DirtDevil)



[Twitter@DirtDevil](https://twitter.com/DirtDevil)

PREPARING THE CARPET

1. Vacuum carpet thoroughly with a Dirt Devil® cleaner.
2. Place plastic or foil under and around the legs of furniture until the carpet has completely dried.

HELPFUL HINTS FOR CLEANING CARPET

- Plan your route so you don't walk over previously cleaned areas.
- Do not oversaturate your carpet with cleaning solution.
- Additional applications may be needed for heavily soiled areas.
- Be sure to rinse carpet thoroughly with water.
- Stay off of the carpet until it is dry.
- Wipe cleaning solution from wood to prevent damage.
- After carpet is dry, vacuum with a Dirt Devil® cleaner.



WARNING

Do not use the carpet cleaner as a dry vacuum.



CAUTION

Do not store the carpet cleaner in garage or area where unit could freeze.

AFTER CLEANING

- Allow carpet to dry completely. Try not to walk on the carpet until it is dry.
- If you need to walk on the carpet, place white towels on the areas you want to walk.
- If the carpet is not dry and the furniture must be placed back in the room, use plastic or foil under the furniture to prevent staining the carpet.
- Thoroughly clean the dirty water tank with hot tap water. See page 14.

NOTE: Do not transport the carpet cleaner with either the Clean Water Solution Tank or Dirty Water Tank full.

HOW TO

REMOVE AND REPLACE CLEAN WATER SOLUTION TANK

1. Press the Clean Water Tank latch.
2. Tip it out like this.

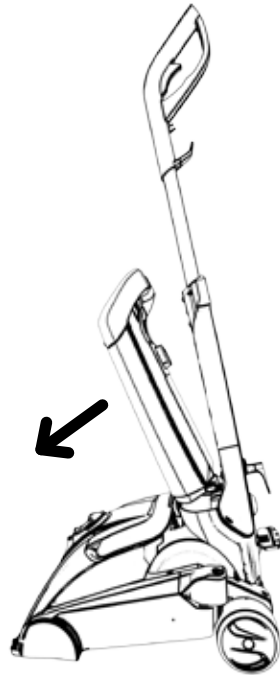
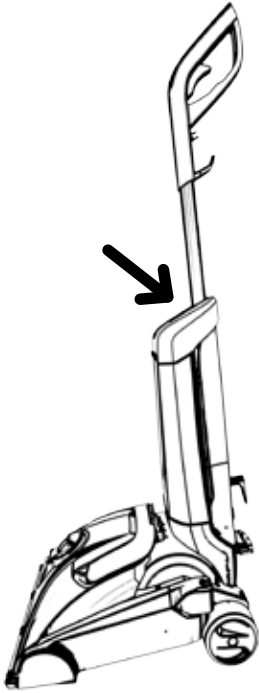

⚠ WARNING

To reduce the risk of fire and electric shock due to internal component damage, use only Dirt Devil brand cleaning fluid intended for use with this appliance. See Cleaning Fluid Section for recommended solutions.

3. Unscrew measuring cap from the back.

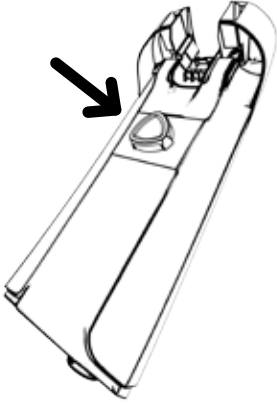

4. For a full size room, place 5 capfuls of Dirt Devil® solution into Clean Water Solution Tank .



5. Fill remaining Clean Water Solution Tank with hot tap water. Tightly screw cap back on.

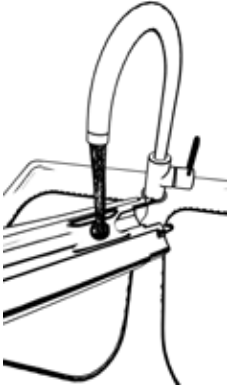

6. Place the Clean Water Solution Tank back in bottom first. It will click.

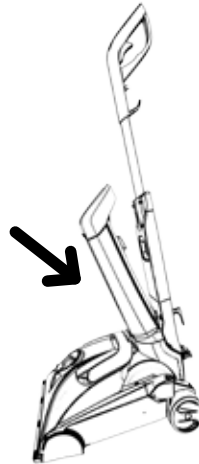

HOW TO

EMPTY THE DIRTY WATER TANK

1. Pull the latch to release.

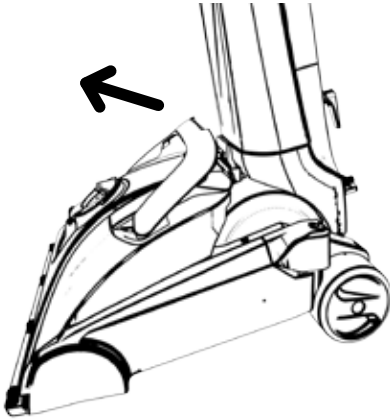

2. Hold the handle and pull tank up and out.

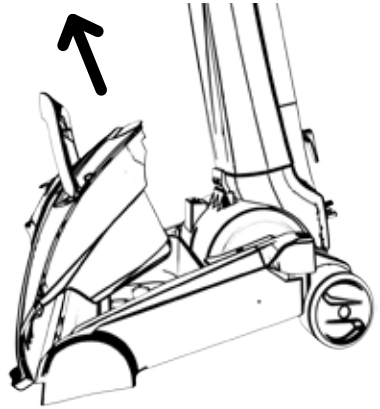

3. Pull lid out and empty like this.

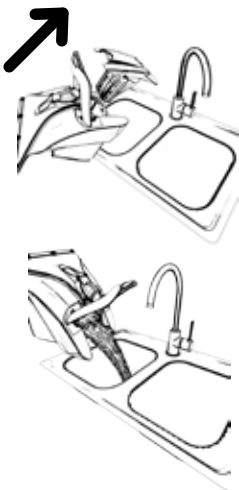

4. Rinse the tank and filter with hot tap water. Wipe and let dry before storing to prevent mildew. Replace the dirty water tank lid.



! IMPORTANT

You will hear a noticeable change in the pitch of the cleaner. This indicates a need to empty the dirty water tank.

! WARNING

To reduce risk of personal injury - unplug cleaner before servicing. Do not use any chemicals when cleaning.

PLACE DIRTY WATER TANK IN BASE OF CLEANER

1. Place carpet cleaner on a flat surface.

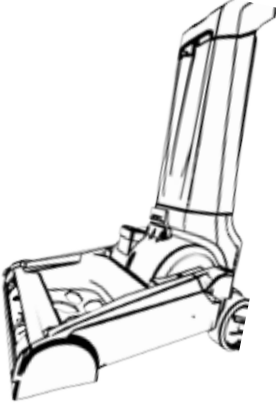

2. Hook the front of the tank into the base. Make sure the tabs on the bottom of the tank are latched.

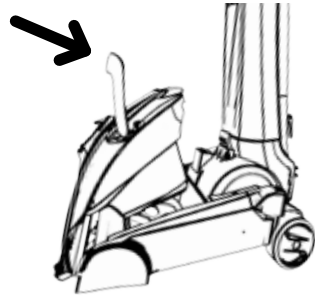

3. The nozzle should be flush with the base. If it's not, this will result in poor water pickup.

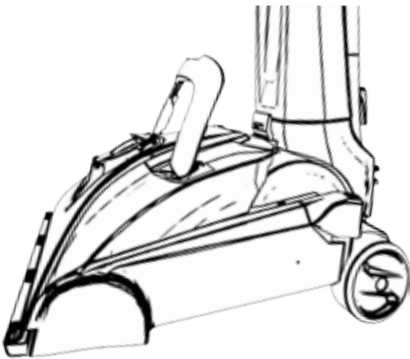

4. Now place the rear of the tank into the base of the cleaner. Push handle down until it clicks.

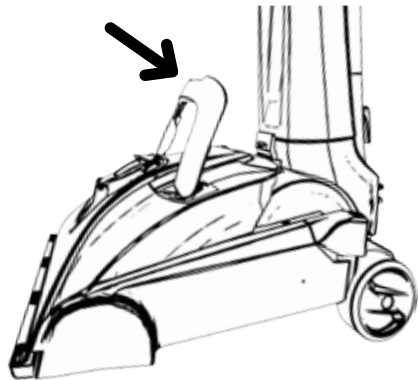

HOW TO

REMOVE THE BRUSHROLL

Note: Be sure to switch off the unit, unplug & remove the clean & dirty water tanks before servicing.



CAUTION

To reduce the risk of injury from moving parts, unplug cleaner before servicing. Rotate brushroll manually to make sure belt is not twisted or pinched.

1. Flip your carpet washer on its side like this.

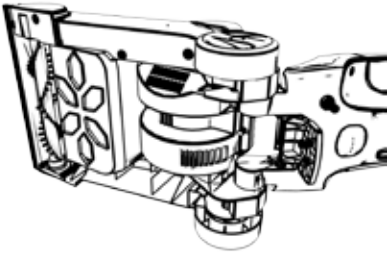

2. Use a Phillips screwdriver to remove the 3 screws here. Now pull cover off.

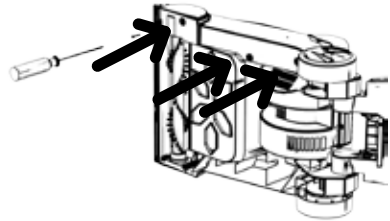

4. Keeping tension on the belt, use two hands to lift the brushroll up and out.

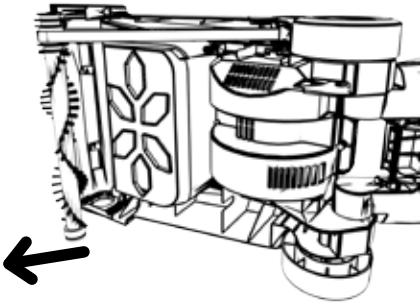

4. Replace belt cover and secure with the three screws.

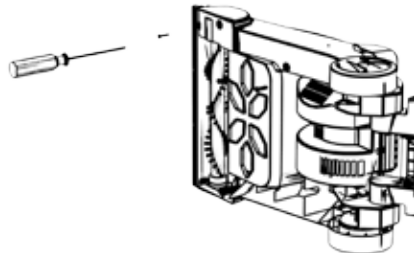

For Belt Style 30 replacements, please call 1-800-321-1134 or visit our website at www.DirtDevil.com to locate a dealer nearest you.

REPLACE THE BELT

1. Take off cover (Refer to page 16). Remove and toss the old belt out.

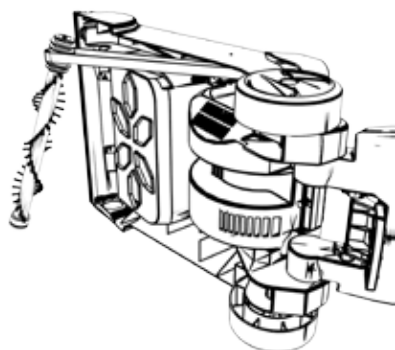

2. Place the new belt on the motorshaft, then slip it in the area without brushroll bristles.

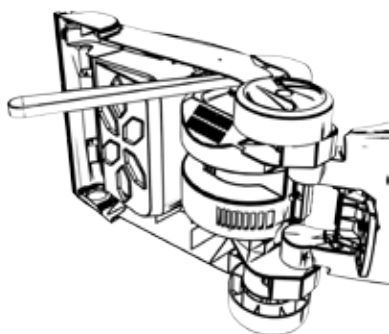

3. With belt in place, pull and slide brushroll into the nozzle, making sure that the brushroll ends are in the correct orientation (A).

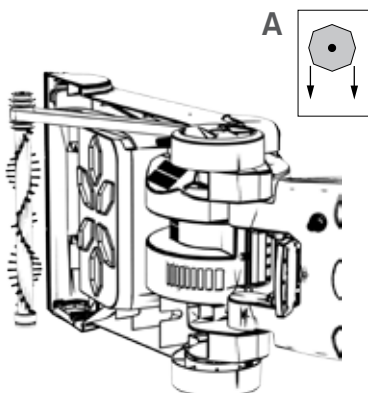

4. Replace belt cover and secure with the three screws.

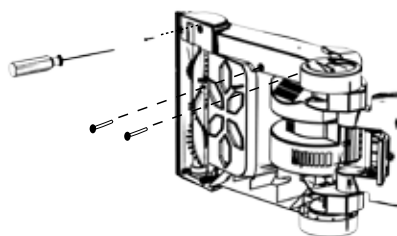

Any other servicing should be done by an authorized service representative. If appliance is not working as it should, has been dropped, damaged, left outdoors, or dropped into water, take it to a service center prior to continuing use.

TROUBLESHOOTING

If a minor problem occurs, it usually can be solved quite easily when the cause is found by using the checklist below. Any other servicing should be done by an authorized service representative. If appliance is not working as it should, has been dropped, damaged, left outdoors, or dropped into water, take it to a service center prior to continuing use.

⚠ WARNING ⚠ TO REDUCE THE RISK OF PERSONAL INJURY - UNPLUG BEFORE CLEANING OR SERVICING.

PROBLEM	POSSIBLE CAUSE	POSSIBLE SOLUTION
Cleaner won't run	<ol style="list-style-type: none"> 1. Power cord not firmly plugged into outlet. 2. Blown fuse or tripped breaker. 3. Needs service. 	<ol style="list-style-type: none"> 1. Plug unit in firmly. 2. Check fuse or breaker in home. Replace fuse/reset breaker in home. 3. Take to service center. To find nearest location, visit our website at www.DirtDevil.com or call 1-800-321-1134.
Cleaner won't pick-up or low suction	<ol style="list-style-type: none"> 1. Dirty Water Tank Lid not installed. 2. Dirty Water Tank is not installed correctly. 3. Dirty Water Tank is full. 4. Dirty water passage clogged. 5. Foam filter is dirty. 	<ol style="list-style-type: none"> 1. Insert Dirty Water Tank Lid - Pg. 14. 2. Review Placing Dirty Water Tank in base of cleaner - Pg. 15. 3. Empty Dirty Water Tank - Pg. 14. 4. Clean Dirty Water Tank - Pg. 14. 5. Clean filter. Review Emptying & Cleaning the Dirty Water Tank - Pg. 14.
Water escaping from Cleaner	<ol style="list-style-type: none"> 1. Dirty Water Tank is full. 2. Dirty Water tank is not installed correctly. 3. Clean Water Solution Tank not installed properly. 	<ol style="list-style-type: none"> 1. Emptying Dirty Water Tank - Pg. 14. 2. Review Placing Dirty Water Tank in base of cleaner - Pg. 15. 3. Review Clean Water Solution Tank Installation - Pg. 12.
Cleaner won't dispense	<ol style="list-style-type: none"> 1. Clean Water Solution Tank not installed properly. 2. Needs service. 	<ol style="list-style-type: none"> 1. Review Clean Water Solution Tank Installation - Pg. 12. 2. Take to service center. To find nearest location, visit our website at www.DirtDevil.com or call 1-800-321-1134.
Motor noise becomes high-pitched	<ol style="list-style-type: none"> 1. The float in the Dirty Water Tank has been activated. 	<ol style="list-style-type: none"> 1. Review Emptying & Cleaning the Dirty Water Tank - Pg. 14.

⚠ WARNING ⚠ TO REDUCE THE RISK OF FIRE AND ELECTRICAL SHOCK DUE TO INTERNAL COMPONENT DAMAGE, USE ONLY DIRT DEVIL® BRAND DETERGENT PRODUCTS INTENDED FOR USE WITH THE APPLIANCE.

Dirt Devil® Cleaning Product Guide		
Product Name	Deep Clean Advanced 64 oz.	Deep Clean Pet 64 oz.
Dirt Devil® Quick & Light	✓	✓

WARRANTY



LIMITED WARRANTY

WHAT THIS WARRANTY COVERS

When used and maintained in normal household use and in accordance with the Owner's Manual, your Dirt Devil® product is warranted against original defects in material and workmanship. During the Warranty Period, We will provide labor and parts, at no cost to you, to correct any such defect in products purchased in the United States, U.S. Military Exchanges and Canada.

HOW TO MAKE A WARRANTY CLAIM

If this product is not as warranted, take or send the product to a Dirt Devil® Authorized Warranty Service Dealer along with proof of purchase. For an automated referral to authorized service outlets in the U.S.A., phone: 1-800-321-1134 OR visit Dirt Devil® online at www.DirtDevil.com. For additional assistance or information concerning this Warranty or the availability of warranty service outlets, phone the Dirt Devil® Consumer Response Center, Phone 1-800-321-1134, Mon-Fri 8am-7pm EST.

WHAT THIS WARRANTY DOES NOT COVER

This Warranty does not cover: use of the product in a commercial operation (such as maid, janitorial and equipment rental services), brushroll, belt, bags, filters, improper maintenance of the product, damage due to misuse, acts of God, nature, vandalism or other acts beyond the control of Royal Appliance Mfg. Co. ("Royal", "we"), owner's acts or omissions, use outside the country in which the product was initially purchased and resales of the product by the original owner. This warranty does not cover pick up, delivery, transportation or house calls.

This warranty does not apply to products purchased outside the United States, including its territories and possessions, outside a U.S. Military Exchange and outside of Canada. This warranty does not cover products purchased from a party that is not an authorized retailer, dealer, or distributor of Royal products.

OTHER IMPORTANT TERMS

This Warranty is not transferable and may not be assigned. This Warranty shall be governed and construed under the laws of the state of Ohio. The Warranty Period will not be extended by any replacement or repair performed under this Warranty.

THIS WARRANTY IS THE EXCLUSIVE WARRANTY AND REMEDY PROVIDED BY ROYAL. ALL OTHER WARRANTIES, EXPRESSED OR IMPLIED, INCLUDING WARRANTIES OF MERCHANTABILITY OR FITNESS FOR PARTICULAR PURPOSE, ARE DISCLAIMED. IN NO EVENT WILL ROYAL BE LIABLE FOR ANY SPECIAL, INDIRECT, INCIDENTAL OR CONSEQUENTIAL DAMAGES OF ANY KIND OR NATURE TO OWNER OR ANY PARTY CLAIMING THROUGH OWNER, WHETHER BASED IN CONTRACT, NEGLIGENCE, TORT OR STRICT PRODUCTS LIABILITY OR ARISING FROM ANY CAUSE WHATSOEVER. Some states do not allow the exclusion of consequential damages, so the above exclusion may not apply to you. This warranty gives you specific rights; you may also have others that vary from state to state.

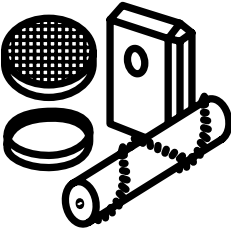

Find GENUINE Replacement Parts at www.dirtdevil.com

This product uses the following parts:

BELT STYLE _____ 30
PRE-MOTOR FILTER _____ F92



Call our Customer Service
Department
at (800) 321-1134

8:00 a.m. - 7:00 p.m. EST Mon. - Fri.
or Sat. 10:00 a.m. - 6:00 p.m. EST.

www.dirtdevil.com

OUR VACS SPEAK VOLUMES

Pick Up the Conversation On...



[Facebook.com/DirtDevil](https://www.facebook.com/DirtDevil)



[Twitter@DirtDevil](https://twitter.com/DirtDevil)