

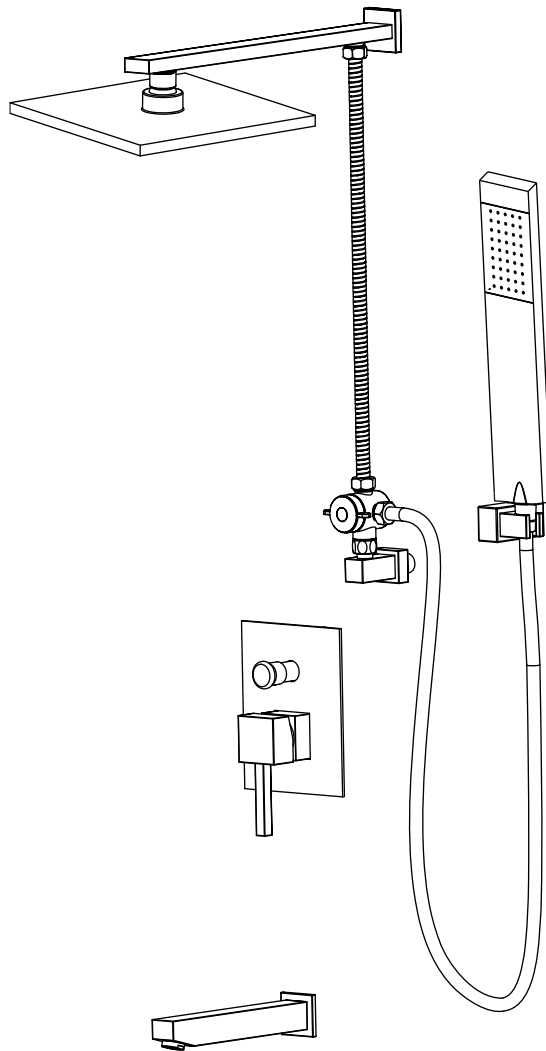

ANZZI™

BYNE SERIES

INSTALL GUIDE



Model#
SH-AZ013

PERFECTION IS OUR TRADITION™

TABLE OF CONTENTS

Parts List	Pg. 1
Before You Start	Pg. 2
Spec Drawing	Pg. 3
Installation	Pg. 4
Care & Maintenance	Pg. 13
Warranty	Pg. 14
Registration	Final Page

YOUR REVIEWS MATTER!



The ANZZI™ Family thanks you for your purchase and hopes you enjoy your very own ANZZI product for years to come! In the meantime let us know about your experience? We would love to hear your thoughts from the packaging to the quality and function of the product.

Leave a review on www.ANZZI.com/reviews and let everyone know how satisfied you are with ANZZI!

Also, we humbly request submitting as many pictures as possible along with your review. Millions of shoppers will want to know about your experience with our products. Don't just tell but show, too!

For more information please call 1-844-44-ANZZI
or email us at support@ANZZI.com

PARTS LIST

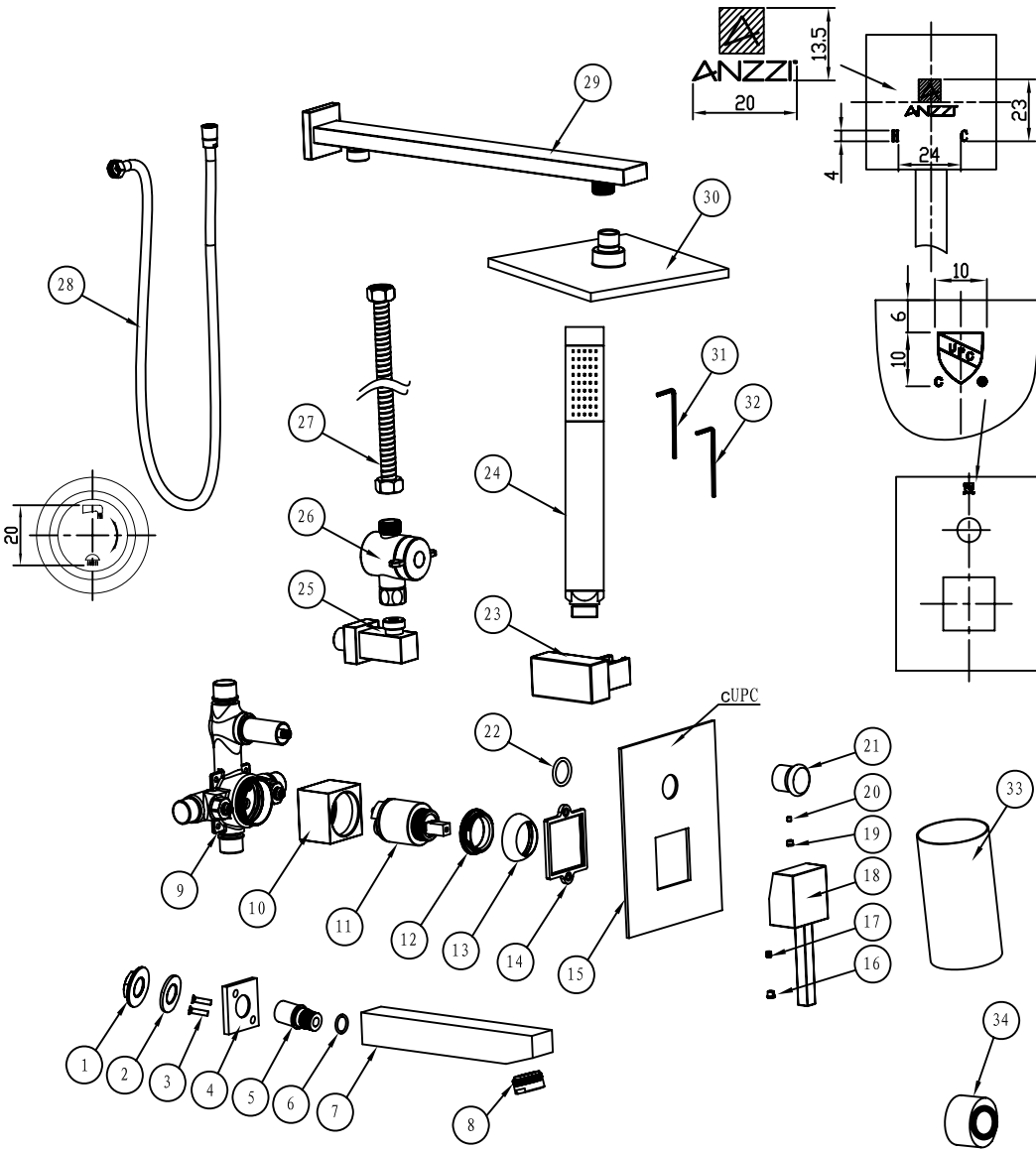

34	Adhesive tape	/	NT	1
33	Protection cover	NBR	NT	1
32	2.0 Spanner	S. S	NT	1
31	Spanner 2.5	S. S	NT	1
30	Shower head	ABS	CP	1
29	Shower arm	Brass	CP	1
28	Shower hose	S. S	CP	1
27	Connecting hose	S. S	CP	1
26	Diverter	ABS	CP	1
25	Adaptor	Brass	CP	1
24	Hand shower	Brass	CP	1
23	Bracket	ABS	CP	1
22	O ring	NBR	NT	1
21	Diverter Knob	Brass	CP	1
20	M4 Screw	S. S	NT	1
19	Plug	NBR	NT	1
18	Handle	Zinc	CP	1
17	M5 Screw	S. S	NT	1
16	Cap	ABS	NC	1
15	Faceplate	Brass	CP	1
14	Washer	NBR	NT	1
13	Shroud	Brass	CP	1
12	Retaining Nut	Brass	NT	1
11	Cartridge	Ceramic	NT	1
10	Sleeve	HPB59-1	CP	1
9	Body	Brass	CP	1
8	Aerator	POM	CP	1
7	Spout	Brass	CP	1
6	O ring	NBR	NT	1
5	Connector	Brass	NC	1
4	Plinth	Brass	CP	1
3	M4 Screw	S. S	NC	2
2	Washer	NBR	NT	1
1	Locking nut	APS	NT	1
SN	Desc.	Material	Finish	Qty



ASME A112.18.1/CSAB125.1

PERFECTION IS OUR TRADITION™

BEFORE YOU START

Recommended Items

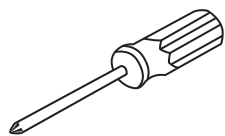

Screwdriver

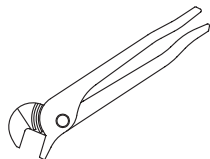

Channel Locks



Goggles

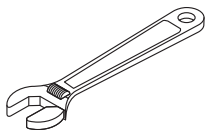

Adjustable Wrench



Teflon tape

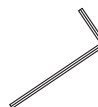

Allen key

ATTENTION: Please read all instructions thoroughly including all warnings, attentions and notes before beginning installation.

For any questions or concerns contact our dedicated technical support team at 1-844-44-ANZZI.

PERFECTION IS OUR TRADITION™

SPEC DRAWING

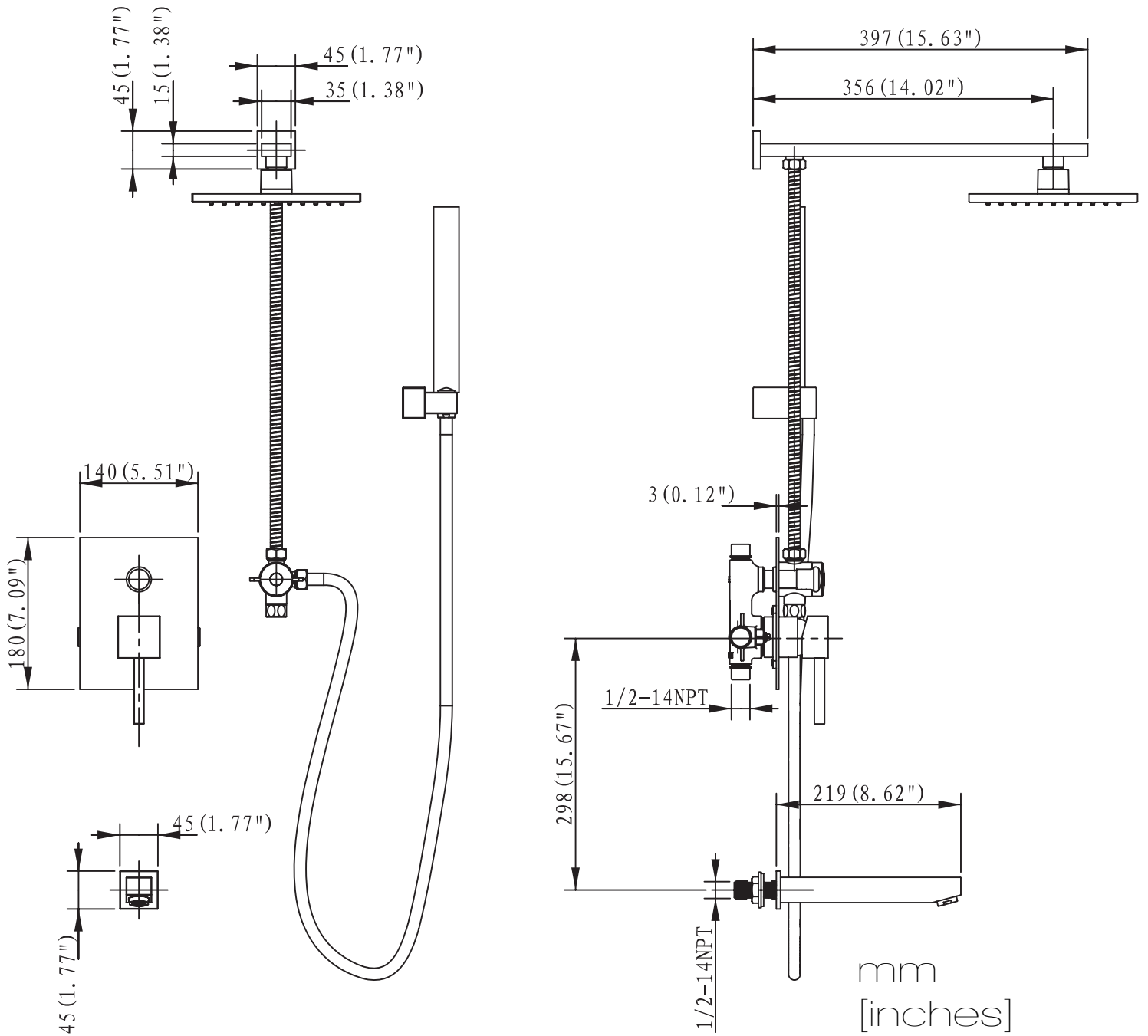

PERFECTION IS OUR TRADITION™

INSTALLATION

Figure 1

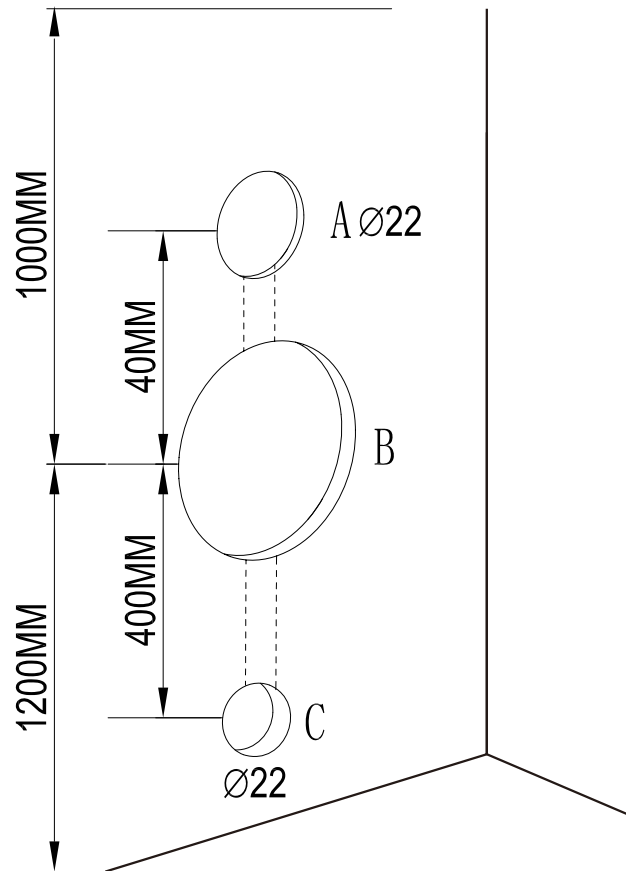

Step 1A Drill holes according to the drawing shown.

INSTALLATION

Figure 2

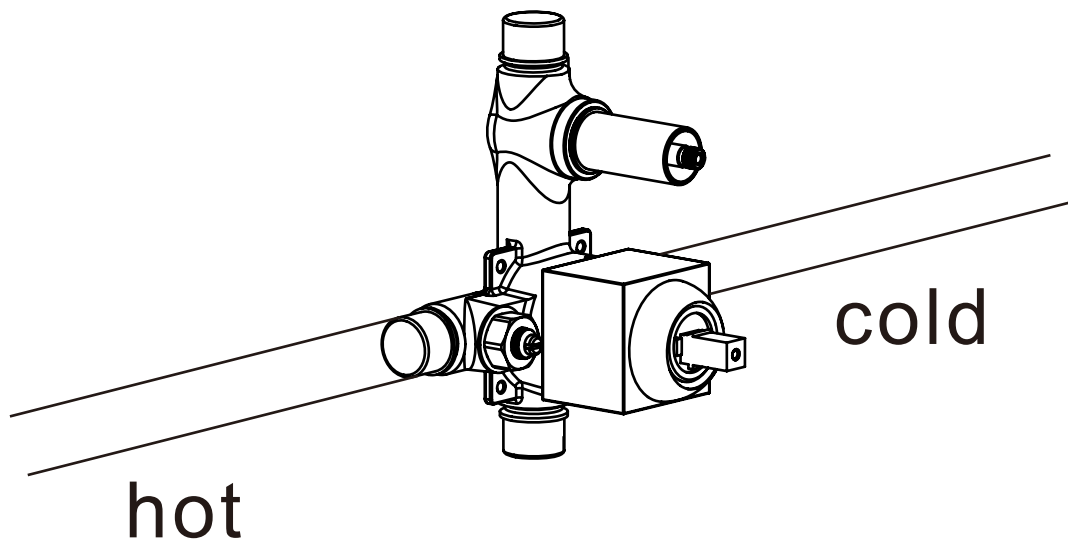

Step 2A Connect plumbing supply lines to the faucet valve as shown.

Step 2B Make sure the hot and cold supply lines are connected to the pertaining sides.

PERFECTION IS OUR TRADITION™

INSTALLATION

Figure 3

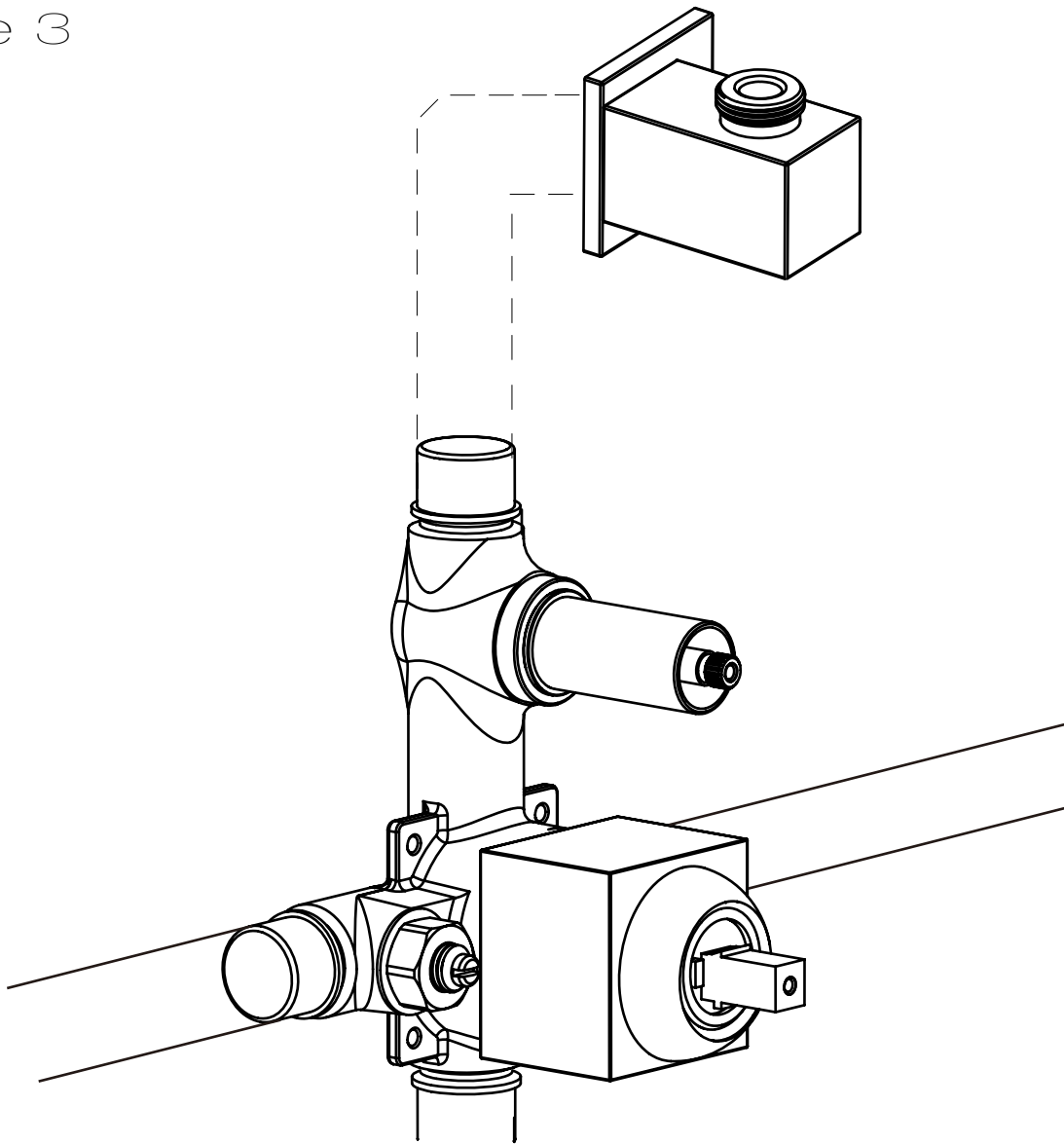

Step 3A Add Teflon tape and screw the diverter adapter to the pipe ran from above the faucet valve.

PERFECTION IS OUR TRADITION™

INSTALLATION

Figure 4

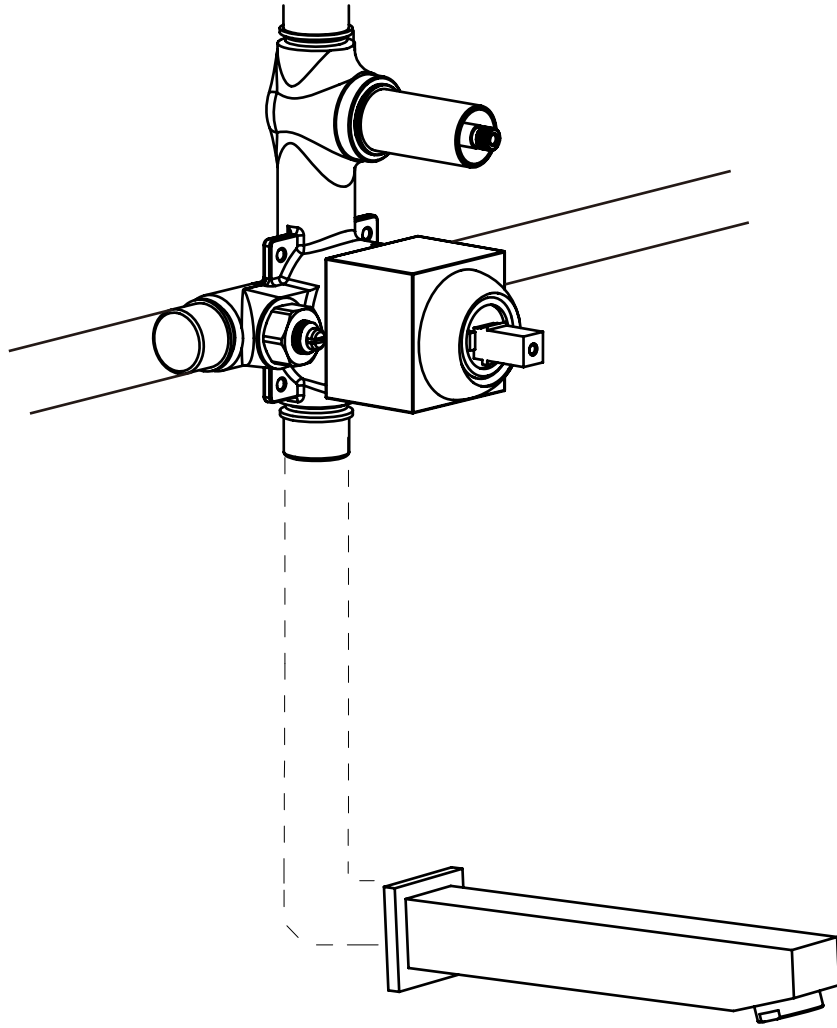

Step 4A The spout comes with a male thread adapter that can be used or removed depending on existing connections.

Step 4B Apply Teflon tape to the pipe connections and screw the spout onto the pipe.

INSTALLATION

Figure 5

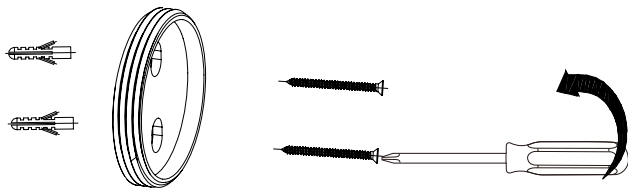
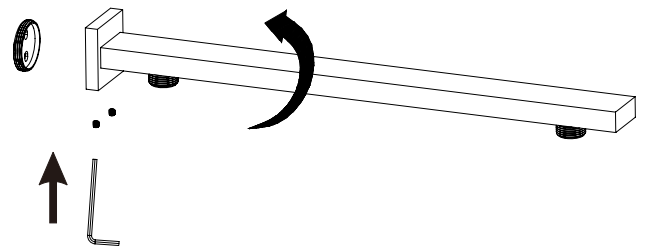

Figure 6



Step 5A Separate the rear anchor for the shower arm.

Step 5B Place the anchor in the desired position.

Step 5C Pre-drilled the holes to insert the wall anchors.

Step 5C Secure the shower arm anchor with the (x2) screws supplied using a Philips screwdriver.

Step 6A Install the shower arm to the anchor until it's tighten in the upright position.

Step 6B Then, secure it using the (x2) set screws provided.

PERFECTION IS OUR TRADITION™

INSTALLATION

Figure 7

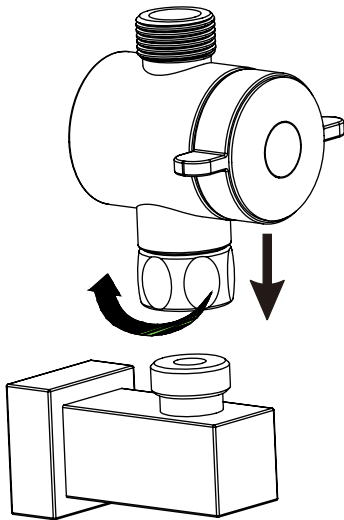
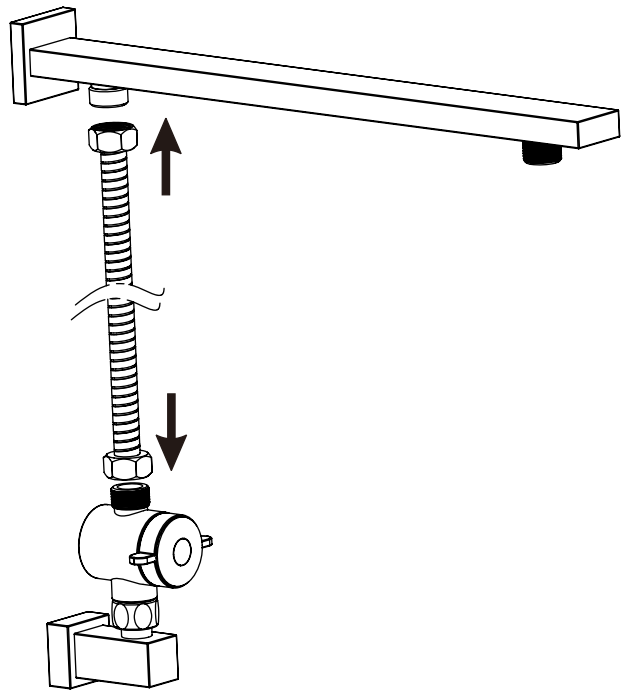

Figure 8



Step 6A Install the shower head & wand diverter to the diverter adapter previously installed (in FIGURE 3).

Step 6B Make sure the black O-ring is inside the diverter before screwing into place.

Step 7A Screw the steel braided hose to the top of the diverter knob and other end of hose to the shower arm.

PERFECTION IS OUR TRADITION™

INSTALLATION

Figure 9

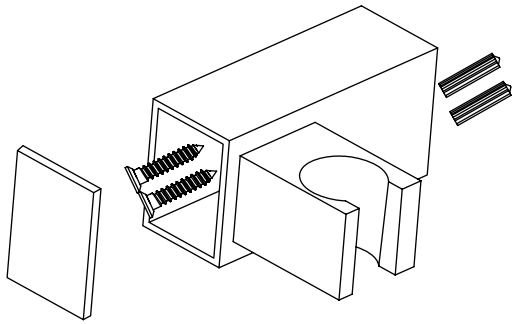
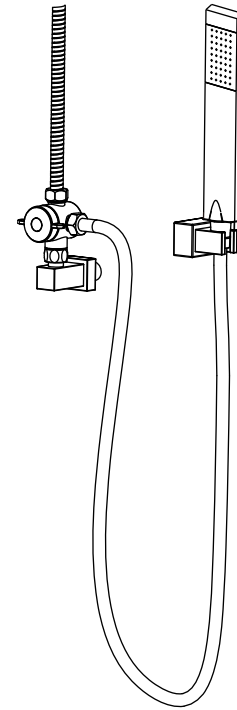

Figure 10



Step 9A Remove end cap, followed by the screws and wall anchors inside.

Step 9B Pre-drill holes to insert wall anchors at your desired position.

Step 9C Then, install the (x2) screws provided using a Philips screwdriver.

Step 10A Connect the longer hose to the right side of the diverter and other end to the shower wand.

PERFECTION IS OUR TRADITION™

INSTALLATION

Figure 11

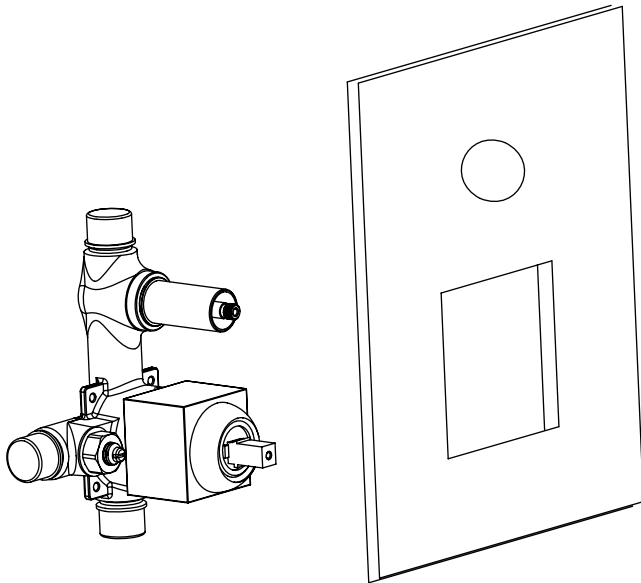
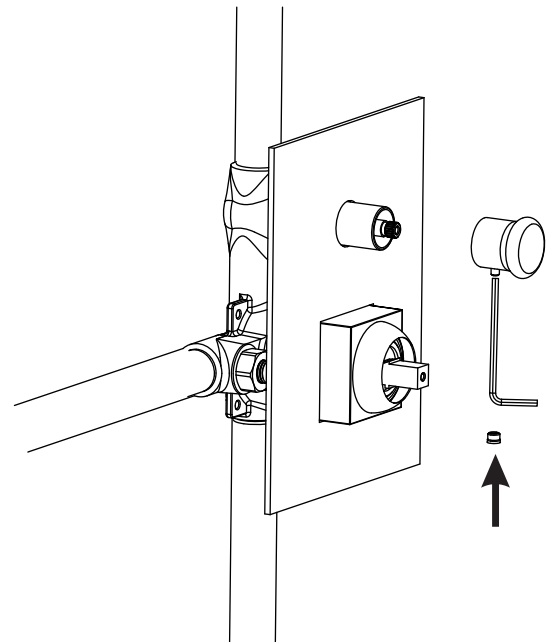

Figure 12



Step 11A Slide the cover plate over faucet valve until it sits up against the finished wall.

Step 11B Apply a bead of silicone all the way around the plate to properly seal.

Step 12A Remove small cap to access set screw.

Step 12B Using the Allen key supplied, tighten set screw after sliding knob in place.

Step 12C Insert the cap after knob has been properly secured.

PERFECTION IS OUR TRADITION™

INSTALLATION

Figure 13

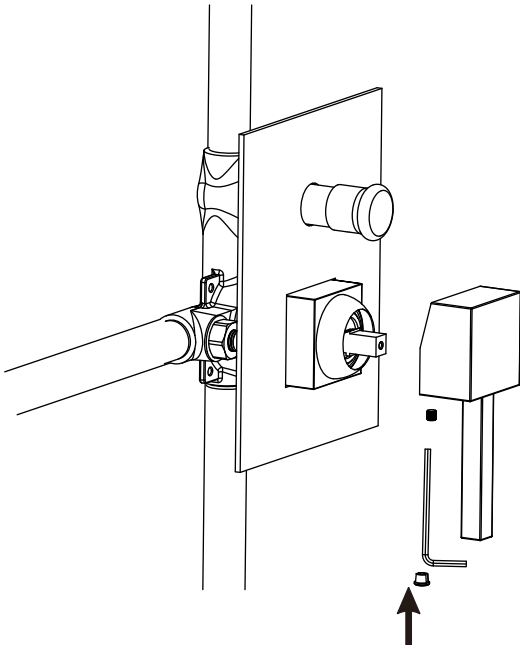
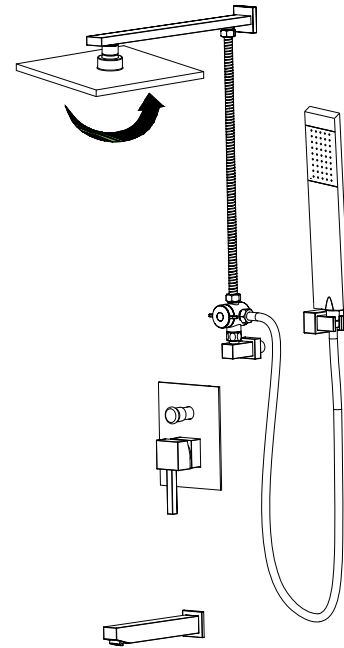

Figure 14



Step 13A Remove small cap located at the bottom side of the faucet handle to access the set screw.

Step 13B Slide knob into place and tighten set screw to secure.

Step 13C Insert the cap to hide set screw.

Step 14A Finally, install the shower head onto the shower arm by screwing it clockwise.

PERFECTION IS OUR TRADITION™

CARE AND MAINTENANCE

ANZZI™ products are crafted with superior quality standards and workmanship and are engineered to stand the test of time. However, that does not mean the product can be neglected and will need some care and cleaning.

It is recommended to use regular soap and hot water along with a non-abrasive cloth or sponge to regularly clean the product. This avoids any nasty build up or deposits which would be tougher to remove.

If you feel the use of stronger cleaning solutions or chemicals is necessary always test the cleaning solution or chemical on an inconspicuous area before applying to the entire surface.

Wipe all surfaces clean and rinse completely with water immediately after applying cleaner. Rinse and dry any overspray that lands on nearby surfaces.

DO NOT ALLOW THE CLEANER TO SOAK.

Following these simple principles will ensure you ANZZI™ product will remain as lustrous and stunning as the day it was first received. ENJOY!

Sincerely,

La Familia ANZZI™

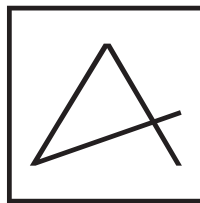

ANZZI™

Perfection is our Tradition™

For more information visit us at www.ANZZI.com

LIMITED LIFETIME WARRANTY

ANZZI™ products are manufactured with superior quality standards and workmanship and are backed by our limited lifetime warranty. ANZZI™ products are warranted to the original consumer purchaser to be free of defects in materials or workmanship. We will replace FREE OF CHARGE* any product or parts that proves defective. Simply call 1-844-44-ANZZI (1-844-442-6994) to submit a warranty claim and request an RMA. Proof of purchase (original sales receipt) from the original consumer purchaser must be made available for all ANZZI™ warranty claims.

This warranty excludes incidental/inconsequential damages and failures due to misuse, abuse or normal wear and tear. This warranty excludes all industrial, commercial & business usage, whose purchasers are hereby, extended a five year limited warranty from the date of purchase, with all other terms of this warranty applying except the duration of warranty.

Some states and provinces do not allow the exclusion or limitation of incidental or consequential damages, so the above limitations may not apply to you. This warranty gives you specific legal rights and you may also have other rights that vary from state to state and province to province. Please contact 1-844-44-ANZZI (1-844-442-6994) or visit www.ANZZI.com/Warranty for more details.

Sincerely,

La Familia ANZZI™

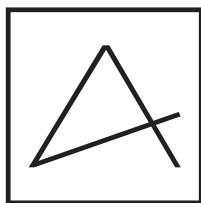

ANZZI™

Perfection is our Tradition™

*Shipping and handling fees are not covered under the ANZZI™ Warranty.

This warranty is in effect as of January, 2016. This warranty supersedes all previous warranties and/or claims both stated and implied. This warranty is subject to change without notice.

PRODUCT AND WARRANTY REGISTRATION

To register your product and activate your Limited Lifetime Warranty contact us at 1-844-44-ANZZI or email us at support@ANZZI.com. Or, if preferable, fill out the form below then scan/fax/mail us a copy.

Email: support@ANZZI.com

Fax: 1-866-560-1060

Mail: ANZZI™
5701 NW 35th Ave.
Miami, FL 33142

In need of replacement parts?
Visit www.SpaWorldParts.com

ANZZI™ Product Registration Card

Name.....

Address

City State Zip

Phone

Email.....

Date of Purchase..... Dealer

Address

Installed by

Address State

Phone State..... Zip.....

Email.....

I have read the ANZZI™ Owner's Manual carefully and understand and agree that any installation, operation or maintenance of the product must be done strictly in accordance with instructions and guidelines contained in the ANZZI™ owner's manual and installation guide.

Signature _____ Date _____

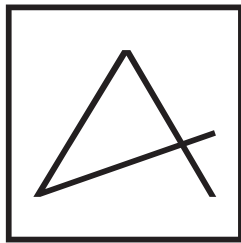

ANZZI™

Perfection is our Tradition™