

DELUXE UNIVERSAL TRAMPOLINE ANCHOR KIT SET OF 6

MODEL# 9302DAK - PRODUCT MANUAL - VERSION 12.18.02 - PATENT PENDING*

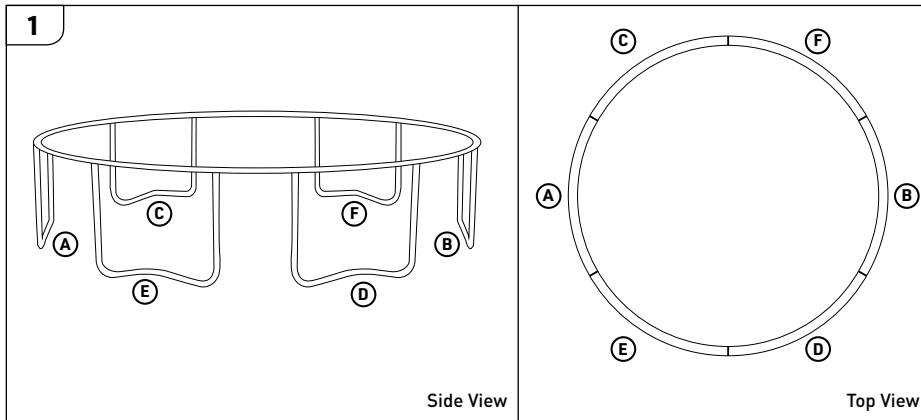

1. Locate all legs of the trampoline to install the wind stakes. In order to keep the trampoline properly grounded you must place stakes evenly distributed around the trampoline as pictured to the right.

EXAMPLE:

Locate Letters A, B, C, D, E, & F on the image shown as an example of where the Wind Stakes can properly be attached.

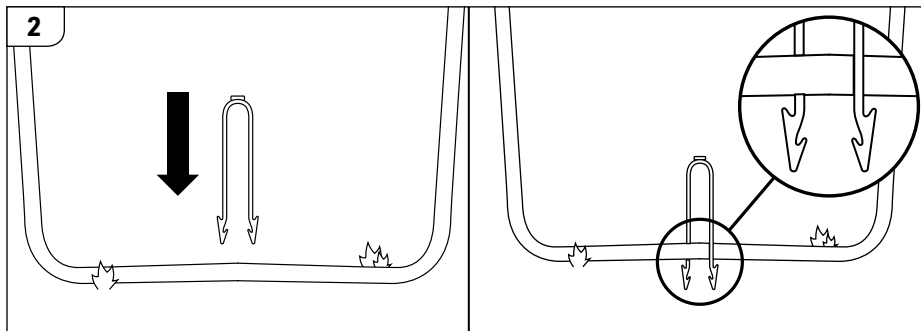

2. To install the Wind Stakes, locate the middle of the U-Shaped Leg and point the legs of the Stakes towards the ground.

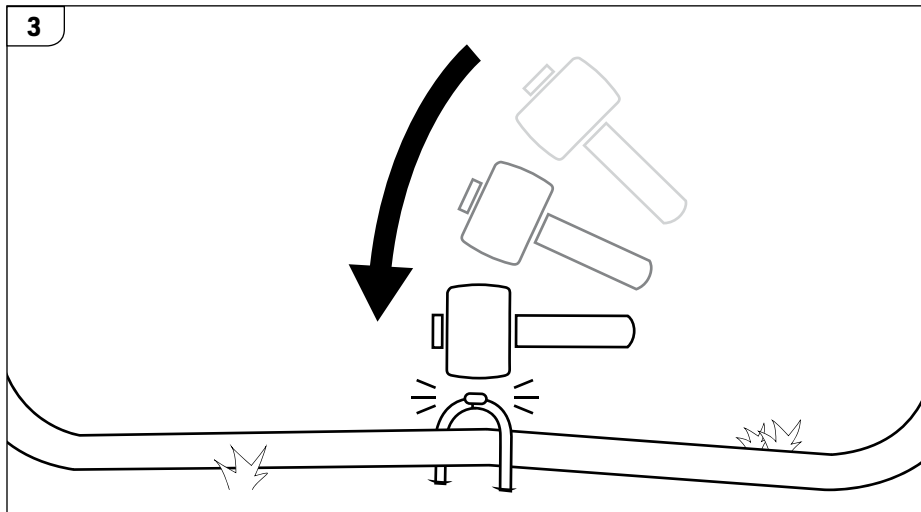

3. Using a rubber mallet, hammer the Stake into the ground by hitting the upper knob of the Wind Stake. Do this until the arch is touching the leg of the U-Shaped Leg.

NOTE:

Do not use any tool other than a rubber mallet to hammer the Wind Stake into the ground, failure to do this will break or crack the product.

4. Repeat Steps 1-3 until all Wind Stakes have been successfully secured into their respective U-Shaped Legs of the Trampoline.

⚠ WARNING

- The Wind Stakes are only meant to assist in keeping your trampoline secure in low to moderate winds. If the soil under your trampoline is of insufficient consistency, or if you live in an area which experiences high winds and/or high wind gusts, Pure Fun recommends that you disassemble your trampoline and safely store it during severe weather.

• ADULT ASSEMBLY REQUIRED

- The installation and use of this kit does not guarantee your trampoline will not be damaged by wind or other severe weather nor does it affect the trampoline warranty
- Do not install in mud, dry soil, sand, frozen or extremely rocky ground.
- Contact your local utility officials to make sure there are no underground utilities where you will be placing the Wind Stakes.

CUSTOMER SERVICE

🌐 PureFun.net

✉ CustomerService@GQBrands.com

☎ 1-866-498-5269

📍 4401 Samuell Blvd, Ste 150
Mesquite, TX 75149

LIMITED WARRANTY:

Global Quality Brands® warrants this product to be free from defects in workmanship and materials under normal use and conditions for a period of 90 DAYS FROM THE DATE OF ORIGINAL PURCHASE. This Limited Warranty is not transferable and is available only for the original purchaser of the Product. The Company's obligation under this warranty is limited to replacing or repairing the Product, at the discretion of the company.

All warranty coverage extends only to the original retail purchaser from the date of purchase, obligation under this warranty is limited to replacing or repairing, at Global Quality Brands® option. All products for which a warranty claim is made must be received by Global Quality Brands® and accompanied by sufficient proof of purchase (photocopy of the original store receipt, indicating the date of purchase). All freight and handling fees are the responsibility of the consumer to pay, both to and from Global Quality Brands®.

All warranty claims must be preauthorized by Global Quality Brands® pre-authorization can be obtained by calling 866-498-5269. This warranty does not cover ordinary wear and tear, weathering, failure to follow directions, improper installation, improper maintenance, or acts of nature, (such as damage caused by wind, lightning, snow, water, or ice) weather damage, damage caused by unauthorized repair work or damage caused by improper use of the products are not covered by the product warranty. No other warranty beyond that specifically set forth above is authorized by Global Quality Brands®.

GLOBAL QUALITY BRANDS® IS NOT RESPONSIBLE OR LIABLE FOR INDIRECT, SPECIAL OR CONSEQUENTIAL DAMAGES ARISING OUT OF OR IN CONNECTION WITH THE USE OR PERFORMANCE OF THE PRODUCT OR OTHER DAMAGES WITH RESPECT TO ANY ECONOMIC LOSS, LOSS OF PROPERTY, LOSS OF REVENUE OR PROFITS, LOSS OF ENJOYMENT OR USE, COST OF REMOVAL, INSTALLATION OR OTHER CONSEQUENTIAL DAMAGES. SOME STATES DO NOT ALLOW THE EXCLUSION OR LIMITATION OF INCIDENTAL OR CONSEQUENTIAL DAMAGES. ACCORDINGLY, THE ABOVE LIMITATION MAY NOT APPLY TO YOU.

THE WARRANTY EXTENDED HEREUNDER IS IN LIEU OF ALL OTHER WARRANTIES AND GLOBAL QUALITY BRANDS®, SPECIFICALLY DISCLAIMS ANY IMPLIED WARRANTY OF MERCHANTABILITY OR FITNESS FOR A PARTICULAR PURPOSE IS LIMITED IN ITS SCOPE AND DURATION TO THE TERMS SET FORTH HEREIN. SOME STATES DO NOT ALLOW LIMITATION ON HOW LONG AN IMPLIED WARRANTY LASTS. ACCORDINGLY, THE ABOVE LIMITATION MAY NO APPLY TO YOU. THIS WARRANTY GIVES YOU SPECIFIC LEGAL RIGHTS. YOU MAY ALSO HAVE OTHER RIGHTS, WHICH VARY FROM STATE TO STATE.

WHILE EVERY ATTEMPT IS MADE TO ENSURE THE HIGHEST DEGREE OF PROTECTION IN ALL EQUIPMENT, WE CANNOT GUARANTEE FREEDOM OF INJURY. THE USER ASSUMES ALL RISK OF INJURY DUE TO USE. ALL MERCHANDISE IS SOLD ON THIS CONDITION, WHICH NO REPRESENTATIVE OF GLOBAL QUALITY BRANDS® CAN WAIVE OR CHANGE.



GQBrands.com

Manufactured by Global Quality Brands
Phone# 866-498-5269
CustomerService@GQBrands.com
4401 Samuell Blvd, Ste 150
Mesquite, TX 75149