

# ASSEMBLY INSTRUCTIONS

## CAPTAINS BED WITH TRUNDLE

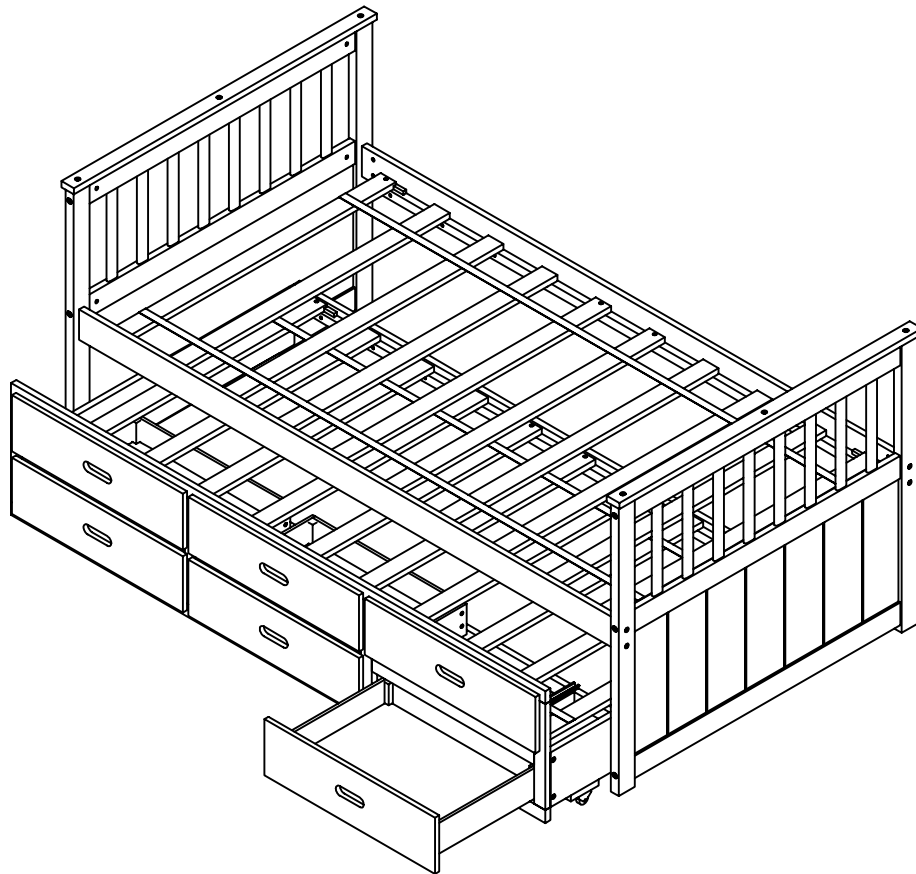



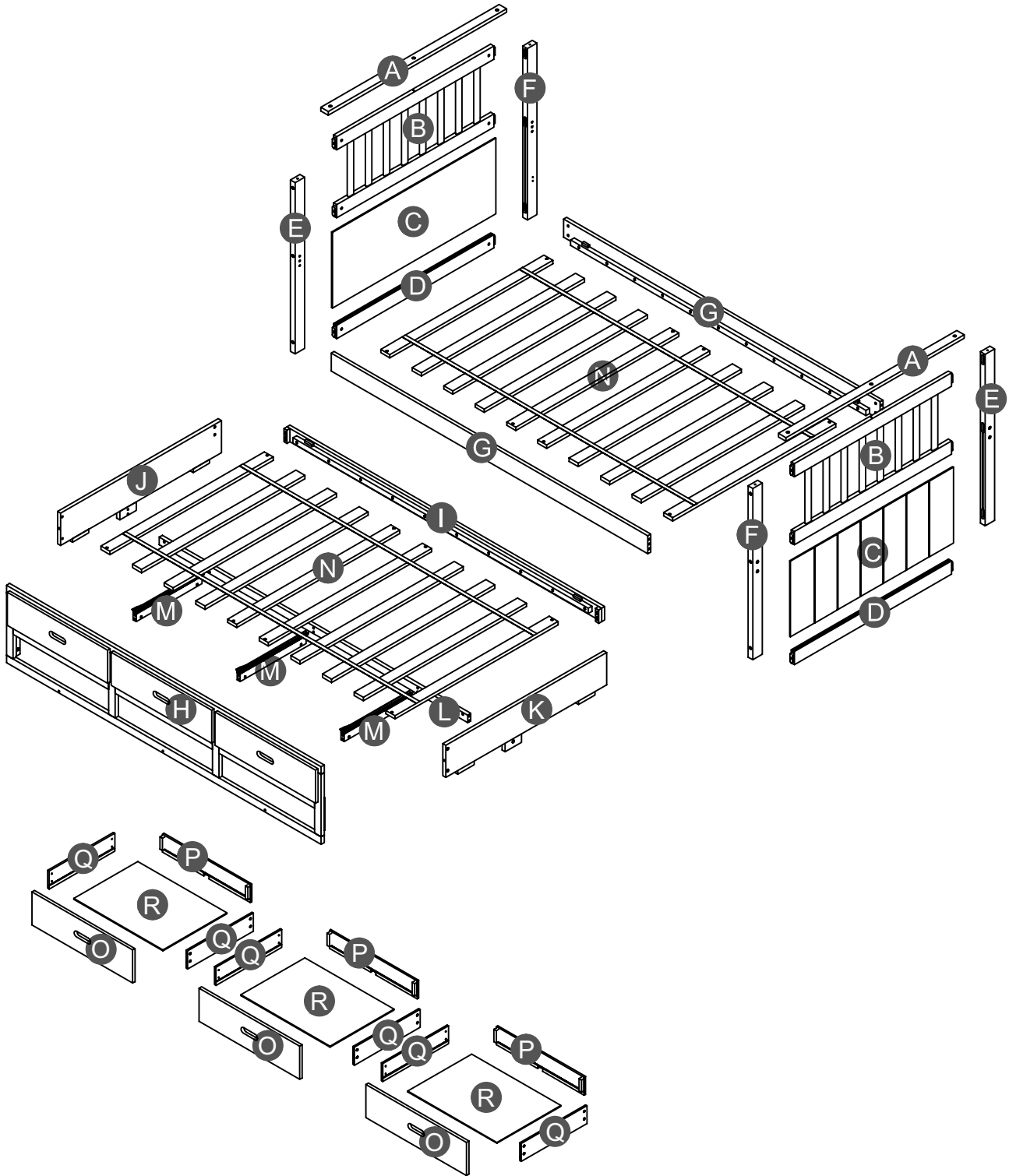

**WF190844/190845**

# Detail View



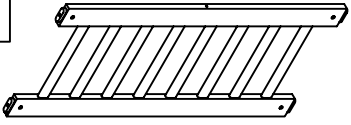
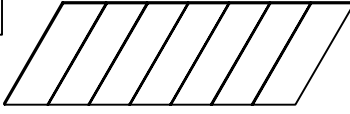

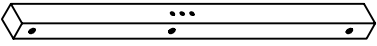

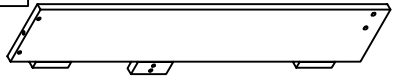
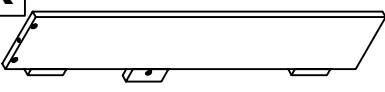
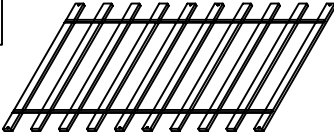
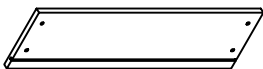
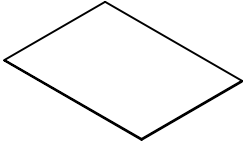

# Part List

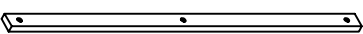

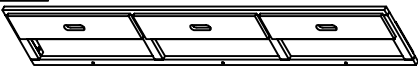

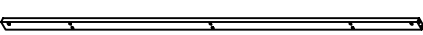
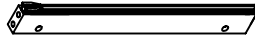





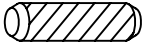

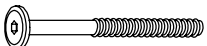
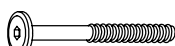
**WF190844**

<b>B</b> 	<b>C</b> 	<b>D</b> 
HB & FB - 2pcs	Side panel - 2pcs	Horizontal bar - 2pcs
<b>E</b> 	<b>F</b> 	<b>J</b> 
Leg HB & FB (Left) - 2pcs	Leg HB & FB (Right) - 2pcs	Left side panel - 1pc
<b>K</b> 	<b>N</b> 	<b>Q</b> 
Right side panel - 1pc	Slats - 2set (20pcs)	Drawer (left & right) - 6pcs
<b>R</b> 		
Drawer botton - 3pcs		

**WF190845**

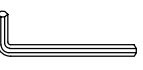
<b>A</b> 	<b>G</b> 	<b>H</b> 
Cap for HB & FB - 2pcs	Side rail(Back & Front)-2pcs	Front panel - 1pc
<b>I</b> 	<b>L</b> 	<b>M</b> 
Back panel - 1pc	Support panel - 1pc	Support drawer - 3pcs
<b>O</b> 	<b>P</b> 	
Drawer front - 3pcs	Drawer back - 3pcs	

# Hardware List

<b>1</b>  Ø8*30mm Wood dowel (8pcs)	<b>2</b>  (Ø15)1/4"*100mm Hex-Head bolts (12pcs)	<b>3</b>  (Ø15)1/4"*80mm Hex-Head bolts (12pcs)
<b>4</b>  (Ø12)1/4"*60mm Hex-Head bolts (8pcs)	<b>5</b>  (Ø12)1/4"*30mm Hex-Head bolts (4pcs)	<b>6</b>  1/4"*15 (9.5mm) Horizontal-Hole bolts(32pcs)
<b>7</b>  Ø3.5*12mm Wood screws (9pcs)	<b>8</b>  Ø3*19mm Wood screws (8pcs)	<b>9</b>  Ø4*30mm Wood screws (16pcs)
<b>10</b>  400*30mm Upper slider drawer (3pcs)	<b>11</b>  (1/4")4.5*58mm Allen key (1pc)	<b>12</b>  45*20*35mm Caster (4pcs)
<b>13</b>  Ø3.5*19mm Wood screws (24pcs)	<b>14</b>  (Ø12)1/4"*40mm Wood screws (6pcs)	

## ASSEMBLY TOOLS REQUIRED ( NOT INCLUDED )

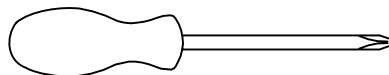

PLEASE BE CAREFUL DO NOT DAMAGE THE HOLE POSITION WHEN YOU USE POWER TOOLS !

**STEP 1:**

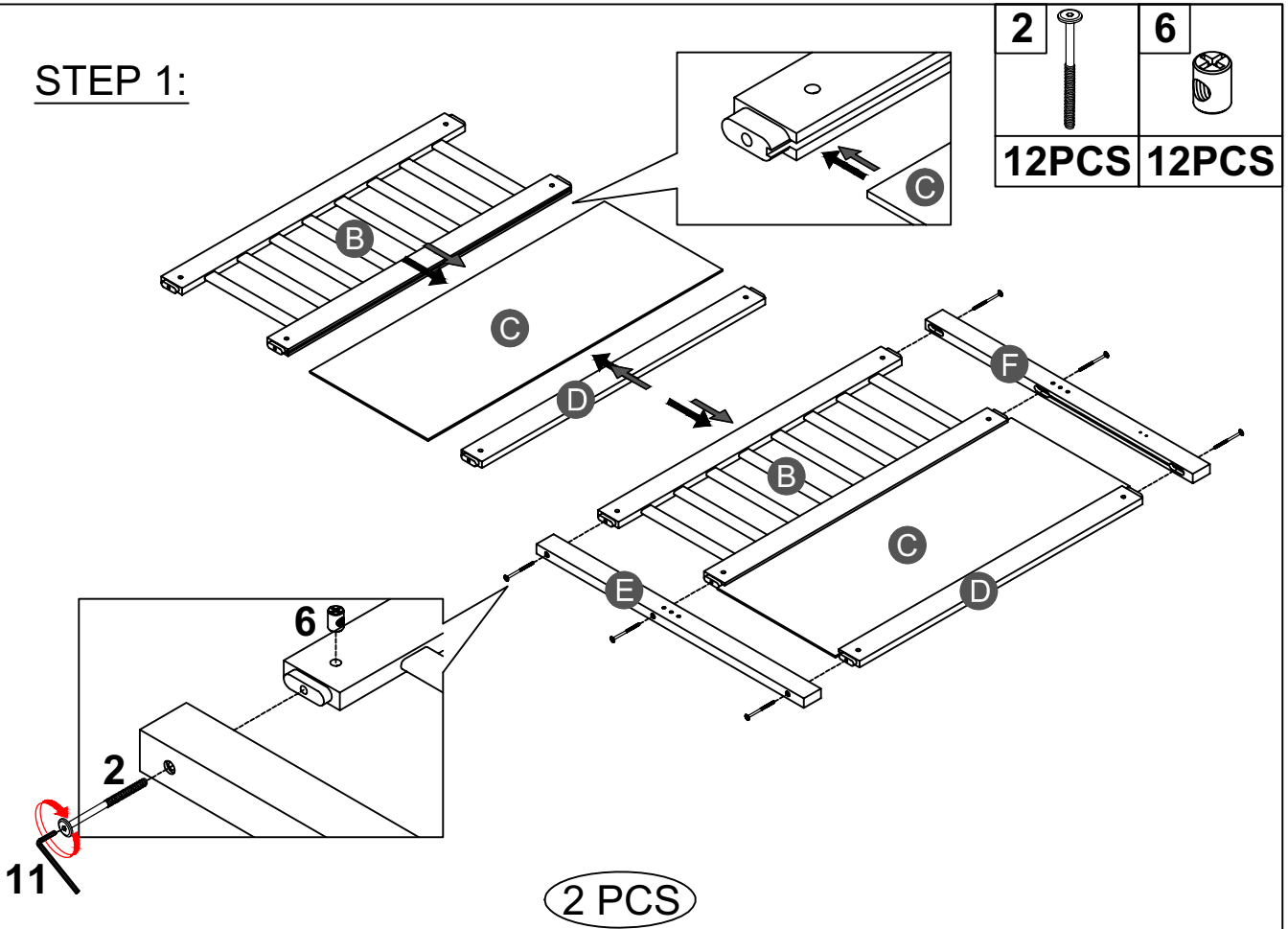

**STEP 2:**

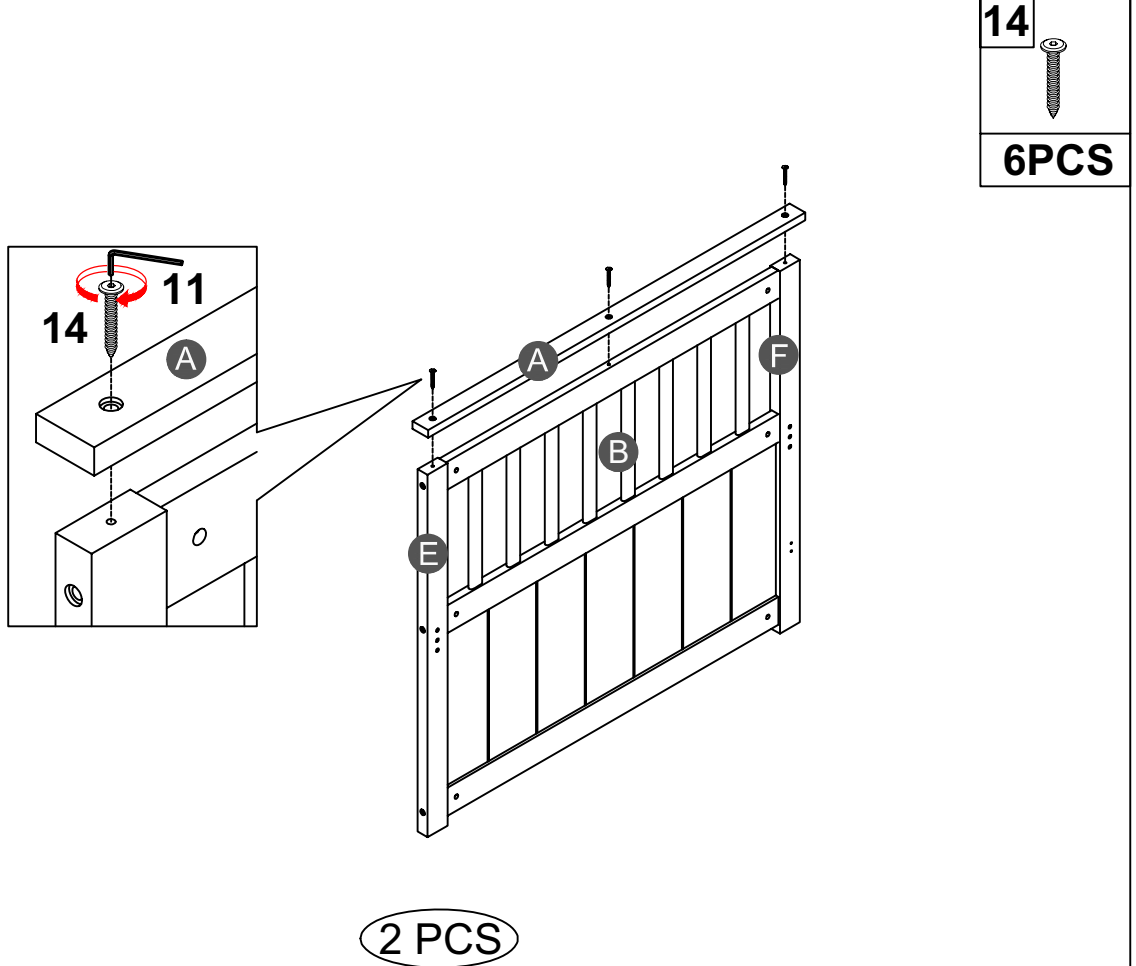

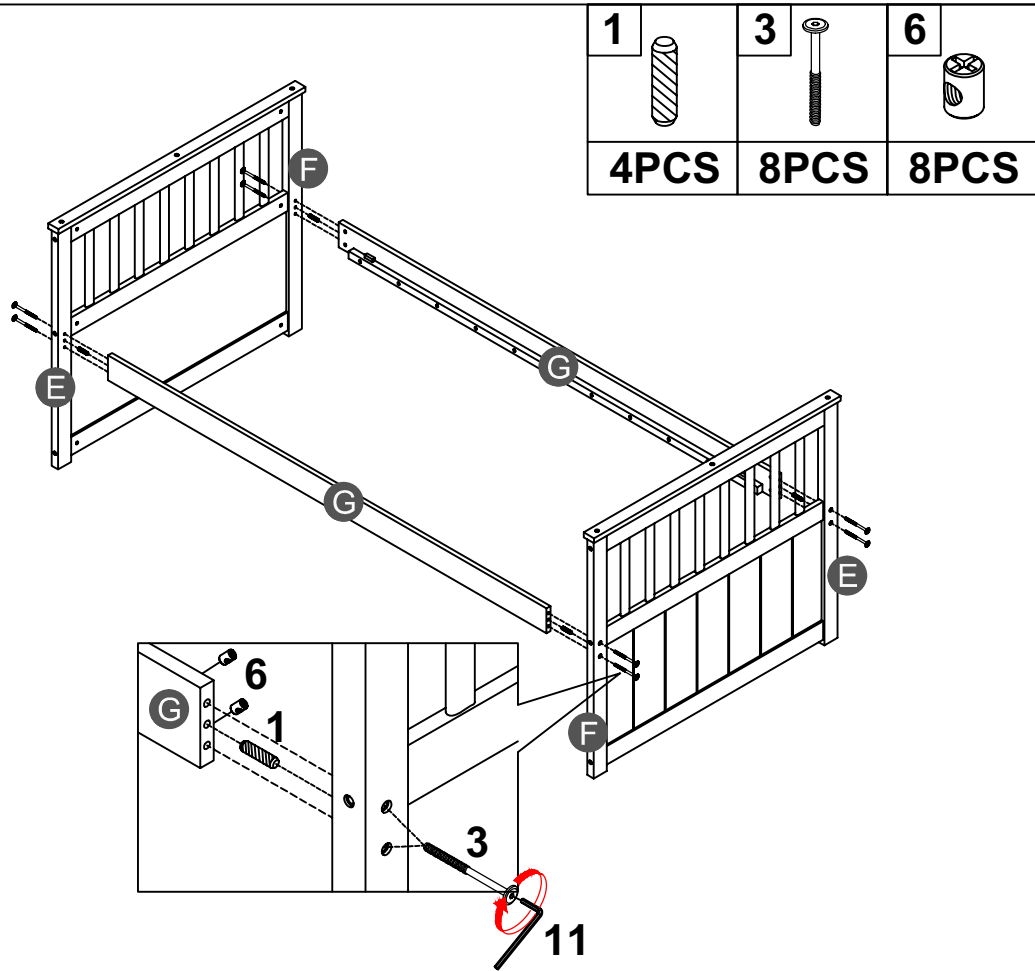

**STEP 3:**

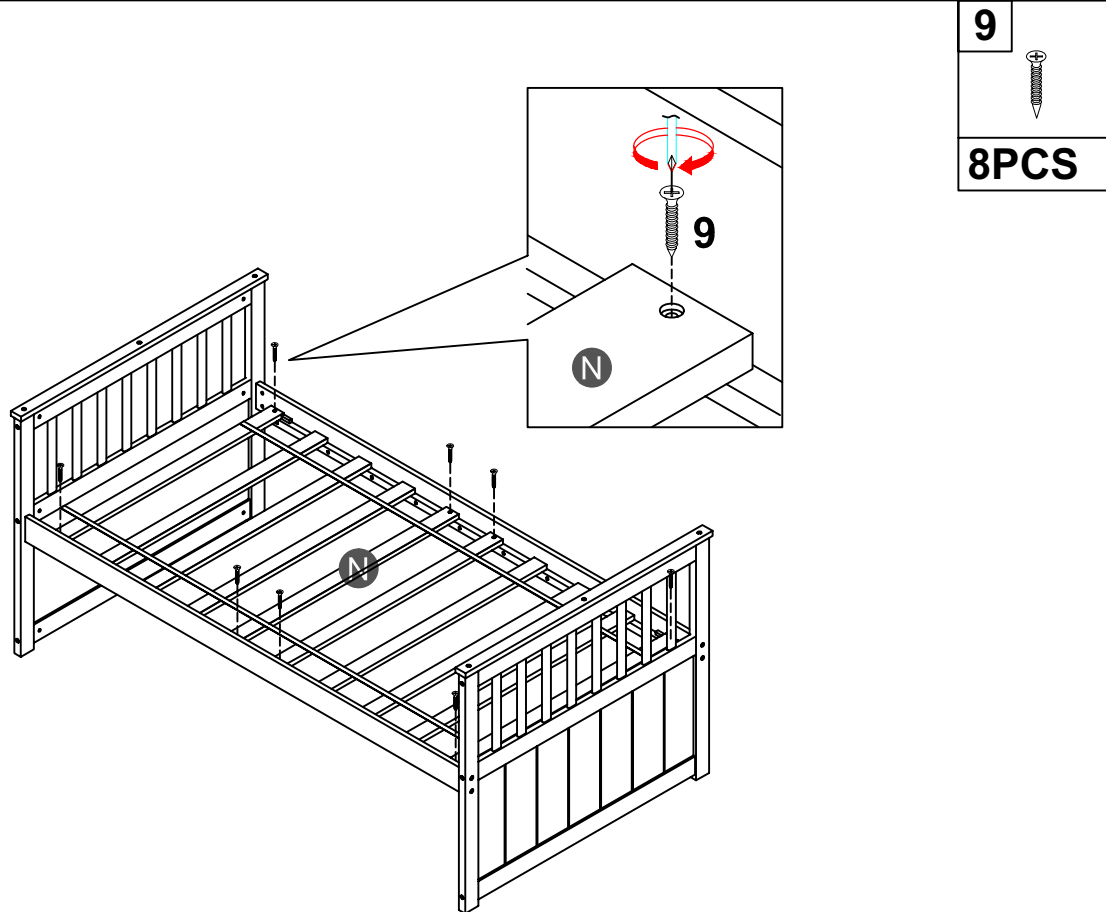

**STEP 4:**





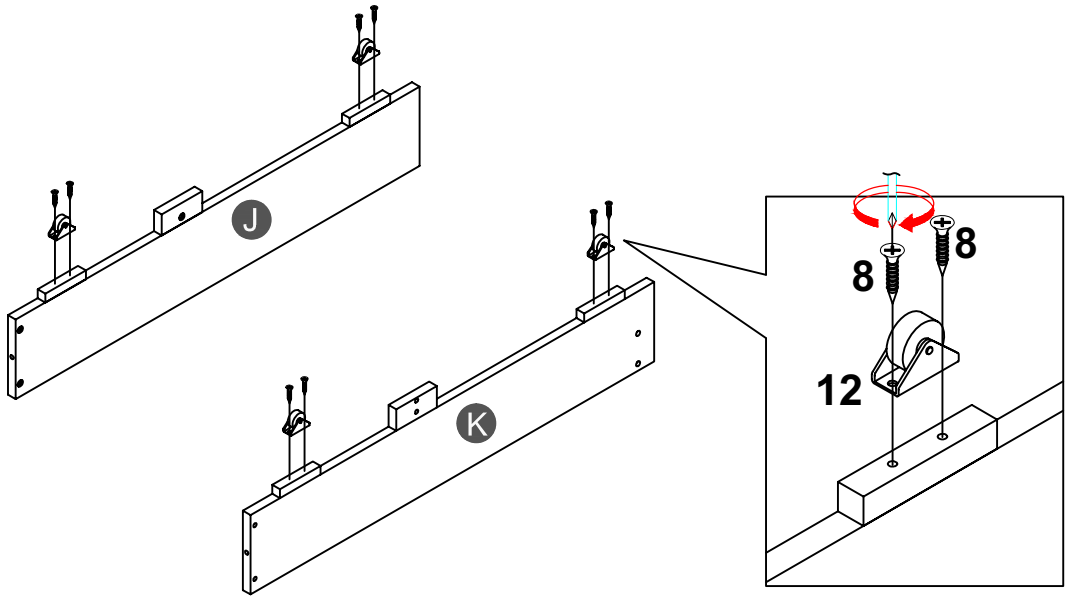

**STEP 5:**

<b>12</b>	<b>8</b>
	
<b>4PCS</b>	<b>8PCS</b>



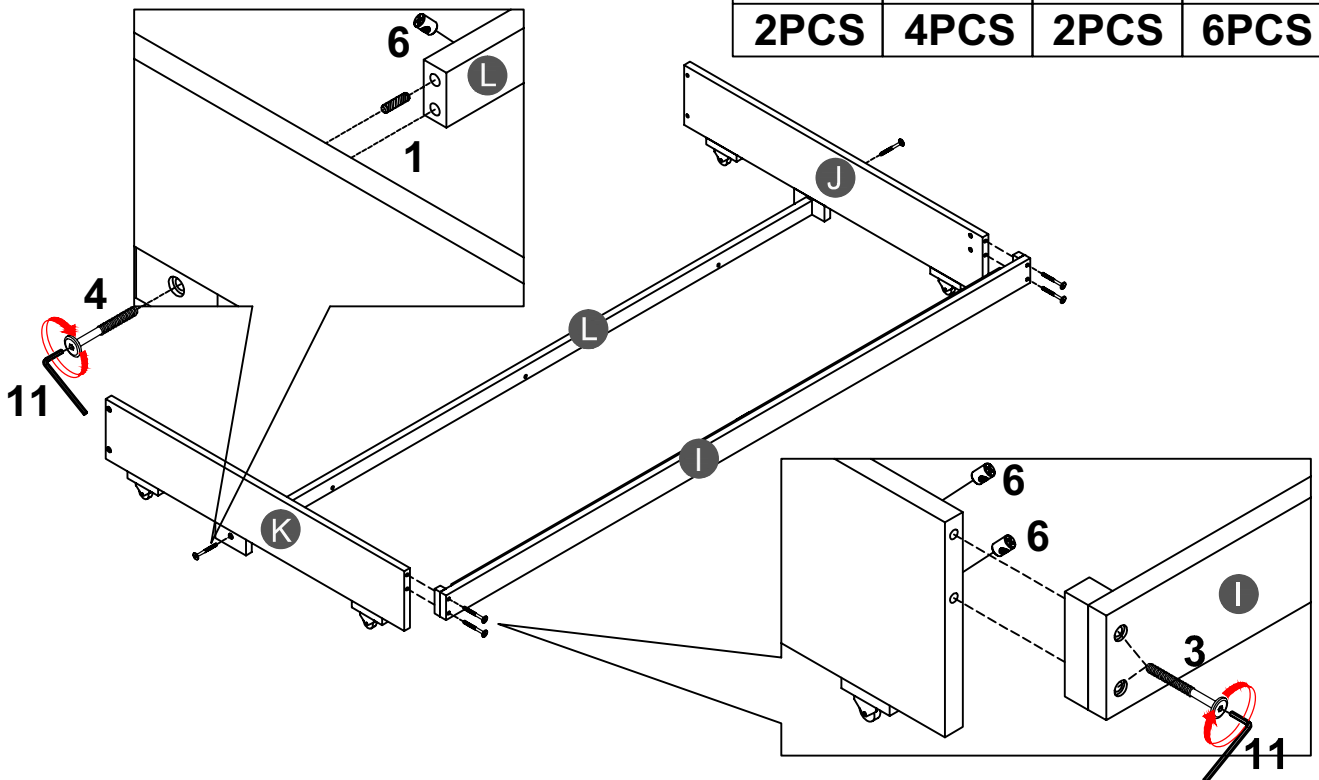

**STEP 6:**

<b>1</b>	<b>3</b>	<b>4</b>	<b>6</b>
			
<b>2PCS</b>	<b>4PCS</b>	<b>2PCS</b>	<b>6PCS</b>





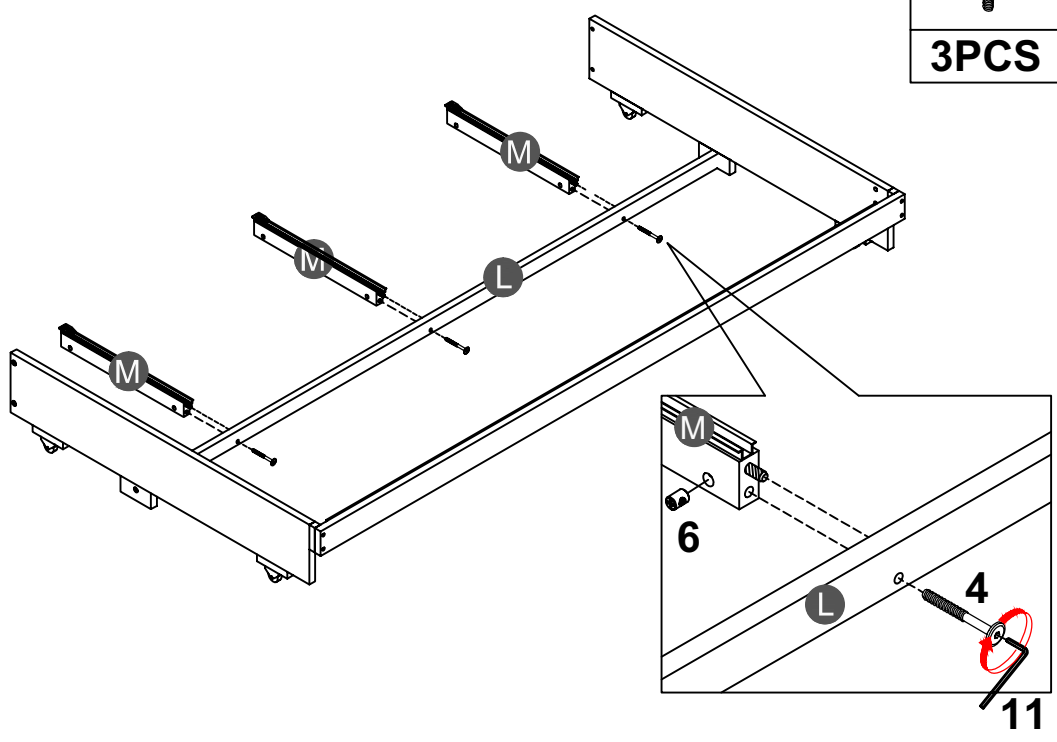

**STEP 7:**

<b>4</b>		<b>6</b>	
<b>3PCS</b>		<b>3PCS</b>	



**STEP 8:**

<b>1</b>		<b>4</b>		<b>5</b>	
<b>2PCS</b>		<b>3PCS</b>		<b>4PCS</b>	
				<b>6</b>	
				<b>3PCS</b>	

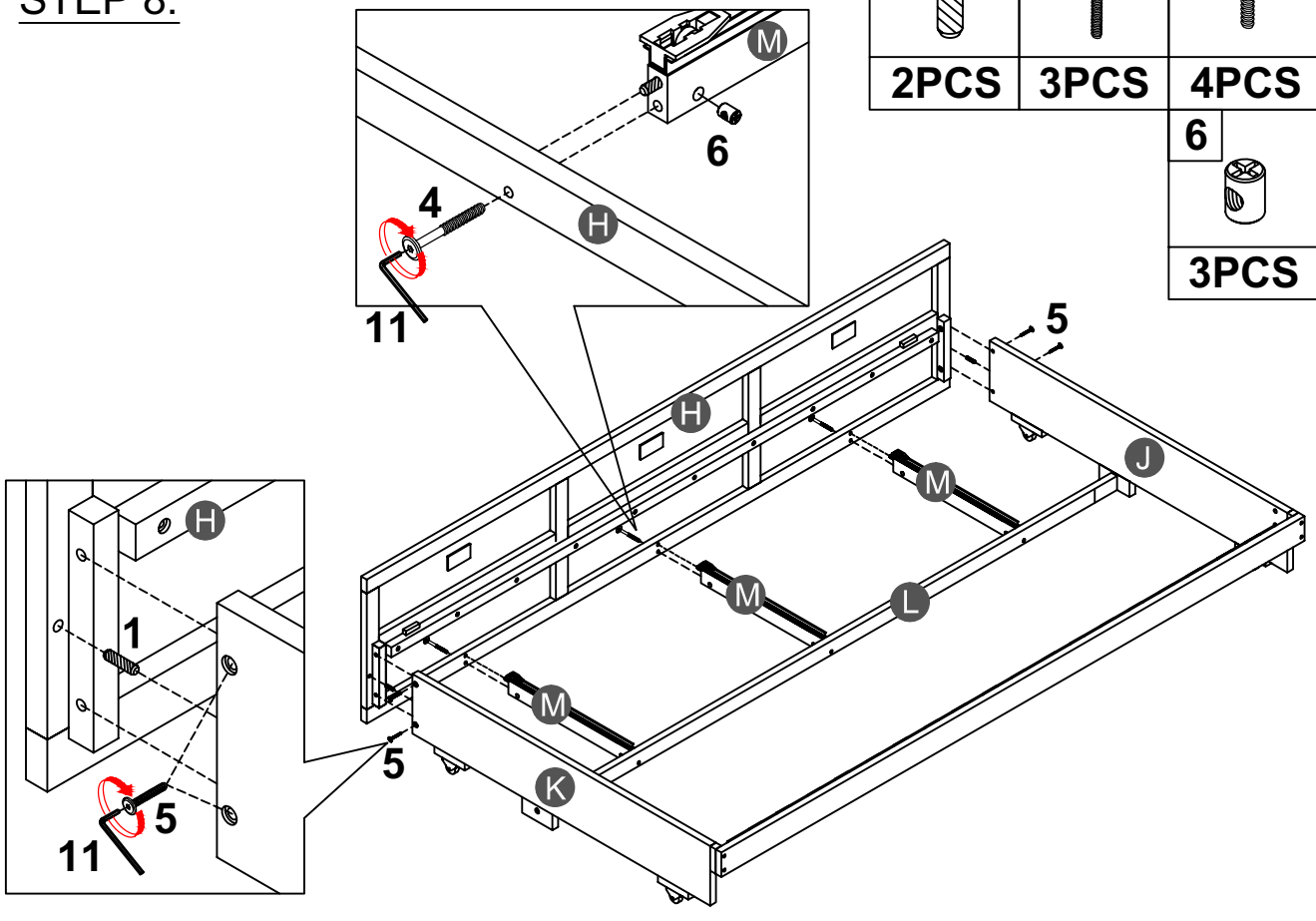



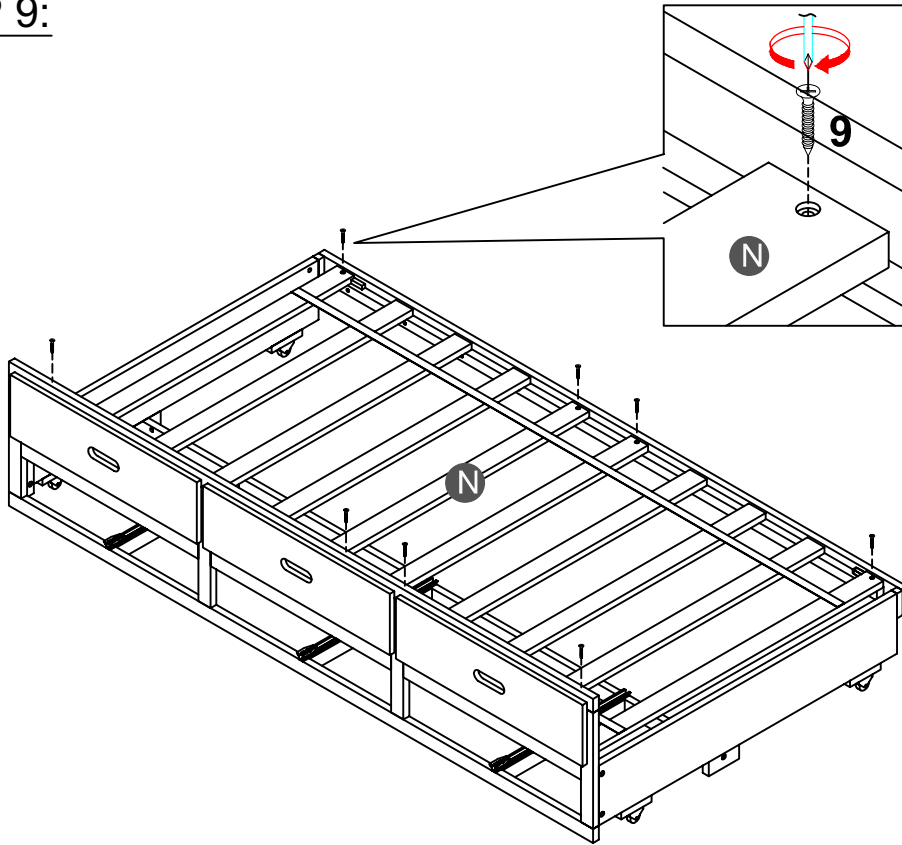

**STEP 9:**

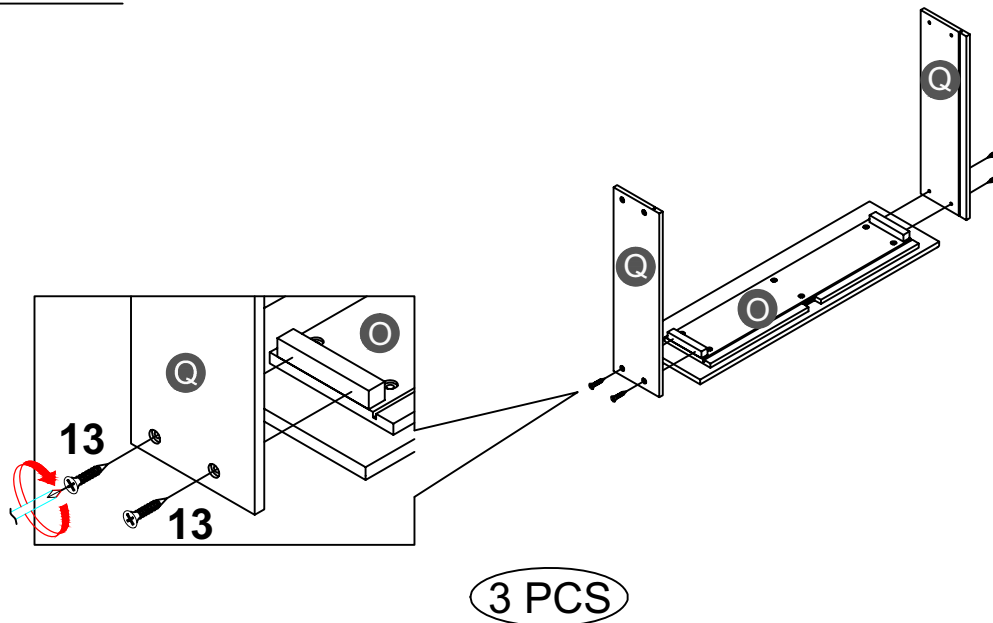

**9**  
  
**8PCS**

**STEP 10:**



**13**  
  
**12PCS**

**3 PCS**

STEP 11:

13



12PCS

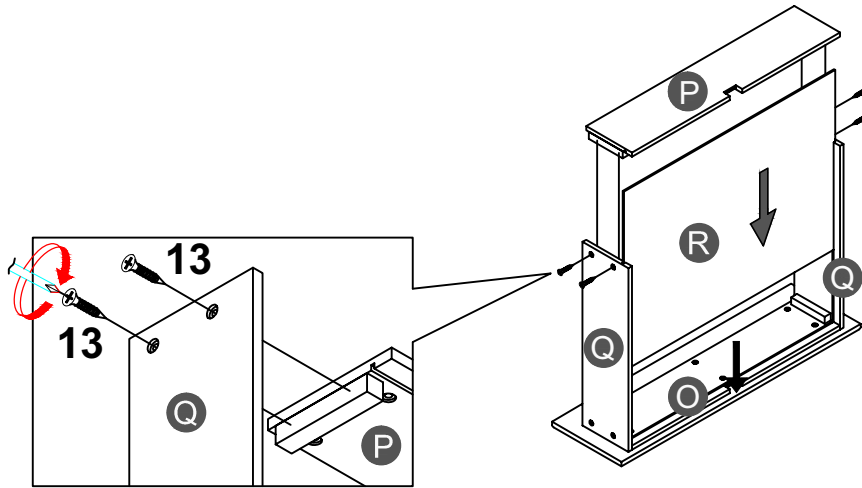

3 PCS

STEP 12:

10



7



3PCS

9PCS

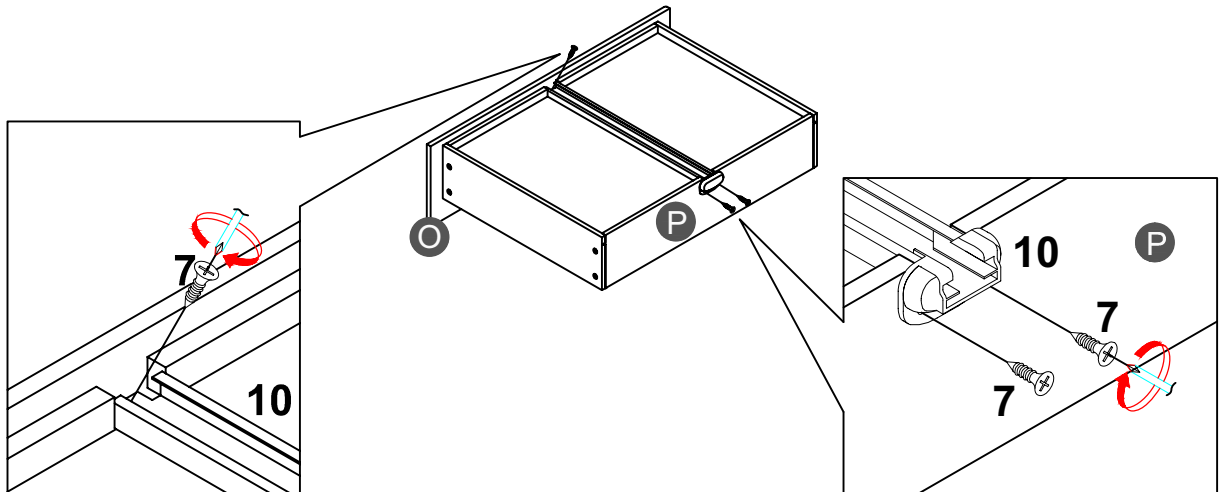

3 PCS

**STEP 13:**

