

# HIT70

## ARC Welder

### Assembly & Operating Instructions



**READ ALL INSTRUCTIONS AND WARNINGS BEFORE USING THIS PRODUCT.**

This manual provides important information on proper operation & maintenance. Every effort has been made to ensure the accuracy of this manual. These instructions are not meant to cover every possible condition and situation that may occur. **We reserve the right to change this product at any time without prior notice.**

**IF THERE IS ANY QUESTION ABOUT A CONDITION BEING SAFE OR UNSAFE, DO NOT OPERATE THIS PRODUCT!**

**HAVE QUESTIONS OR PROBLEMS? DO NOT RETURN THIS PRODUCT TO THE RETAILER - CONTACT CUSTOMER SERVICE.**

If you experience a problem or need parts for this product, visit our website <http://www.buffalotools.com> or call our customer help line at **1-888-287-6981**, Monday-Friday, 8 AM - 4 PM Central Time. A copy of the sales receipt is required.

**FOR CONSUMER USE ONLY – NOT FOR PROFESSIONAL USE.**

**KEEP THIS MANUAL, SALES RECEIPT & APPLICABLE WARRANTY FOR FUTURE REFERENCE.**

## GENERAL PRODUCT SPECIFICATIONS

### SPECIFICATIONS

Amperage Output: 50 (Low), 70 (High)

Two Voltage Settings For Better Heat Control

Primary Input 20 Amps

Open Circuit Volts (Max) 42VAC

Duty Cycle Rating 20% @ 50A

Electrode Diameter 1/16" , 5/64"

Suggested Electrodes: E6013

### FEATURES:

Advanced Thermal Overload Protection  
For Transformer

Includes Welding Cable & Electrode Holder, Grounding Cable  
& Earth Clamp, Clipping Hammer/Brush &  
Welding Face Shield

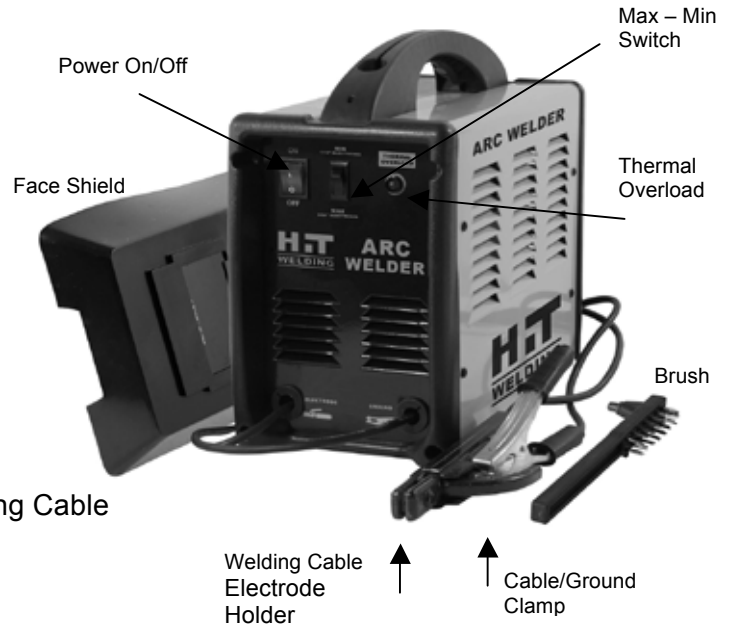

## **⚠ WARNING**

**This product contains chemicals known to the State of California to cause cancer and birth effects or other reproductive harm.**

**KEEP THIS MANUAL, SALES RECEIPT & APPLICABLE WARRANTY FOR FUTURE REFERENCE.**

**READ ALL INSTRUCTIONS AND WARNINGS BEFORE USING THIS PRODUCT.**

When unpacking, check to make sure all parts listed are included. If any parts are missing or broken, please call Customer Service at 1-888-287-6981.

**FOR CONSUMER USE ONLY – NOT FOR PROFESSIONAL USE**

**SAVE THESE INSTRUCTIONS FOR FUTURE REFERENCE.**

This manual contains important information regarding safety, operation, maintenance and storage of this product. Before use, read carefully and understand all warnings, cautions, instructions and labels. Failure to do so could result in serious personal injury, property damage or even death.

### IMPORTANT SAFETY RULES

COMMON SENSE AND CAUTION ARE FACTORS WHICH CANNOT BE BUILT INTO ANY PRODUCT. THESE FACTORS MUST BE SUPPLIED BY THE OPERATOR.

## GENERAL PRODUCT INFORMATION

*Please read and save these instructions. Read through this owner's manual carefully before using product. Protect yourself and others by observing all safety information, warnings, and cautions. Failure to comply with instructions could result in personal injury and/or damage to product or property. Please retain instructions for future reference.*

### Description

Arc70 is a portable AC Arc Welder. It uses single phase 120VAC , 60HZ. Power requires a 20 amp time delayed fuse or circuit breaker.

Out put is 50 amps at 20% duty cycle, OCV 42 VDC. Also includes load and thermal protection. Designed to use for mild steel or alloys in DIY applications. Welds up to 1/8" mild steel.



### Specifications and Dimension

MODEL	SPECIFICATION
Power supply	1ph-120V-60HZ
No-load voltage (OCV)	42V
Output Range	50/70A
Duty cycle	20%
Suggested electrodes	E6013
Electrode Diameter	1/16", 5/64"
Dimension (L x W x H)	13"x 6.7"x 10.2"
Weight	27lbs

### Removing from the carton

- 1.1 Remove cartons, bags or Styrofoam containing the welder and accessories.
- 1.2 Check the contents with the packing list below.

ITEM	QTY.
Portable Arc Welder	1 unit
Hammer/brush	1pc
Operator's Manual	1pc

## GENERAL PRODUCT INFORMATION

1.3 After unpacking unit, inspect carefully for any damage that may have occurred during transit. Check for loose, missing, or damaged parts. Shipping damage claim must be filed with carrier.

### Know your Welder

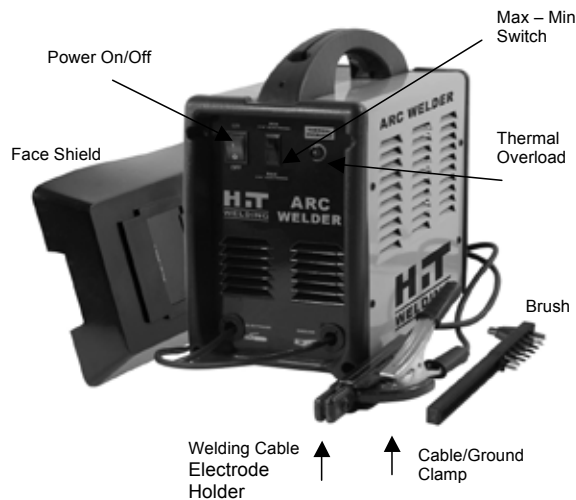

#### ON/OFF switch

In the “off” position no power is being supplied to the welder. In the “ON” position power is supplied to the main transformer and control circuit and electrode.

#### MIN/MAX switch

MIN/MAX switch is on the front panel of machine, it controls the current flow. MIN is for 1/16” electrodes and MAX is for 5/64”.

#### Thermal indicator

If welding at high amperage for an extended time the duty cycle can be exceeded, the overload light will come on (orange), the machine will stop working until the temperature decreases to the acceptable operating temperature range. If the overload light comes on it will take about 15 minutes for the unit to cool down and be ready to use.

#### Ground cable and clamp

The ground cable and clamp is attached to the work piece to complete the flow of current needed to weld.

#### Welding cable and electrode Holder

The electrode holder is where the electrodes are held for welding.

#### Power cord

The power cord connects the welder to the 120 volt power supply. Plug the 15 amp plug into a 120 volt/20 amp receptacle to supply power to the welder

## GENERAL PRODUCT INFORMATION

### General Safety Information

#### 1.1 Your Welding Environment

- Keep the environment you will be welding in free from flammable materials.
- Always keep a fire extinguisher accessible to your welding environment.
- Always have a qualified person install and operate this equipment.
- Make sure the area is clean, dry and ventilated. Do not operate the welder in humid, wet or poorly ventilated areas.
- Always have your welder maintained by a qualified technician in accordance with local, state and national codes.
- Always be aware of your work environment. Be sure to keep other people, especially children, away from you while welding.
- Keep harmful arc rays shielded from the view of others.
- Mount the welder on a secure bench or cart that will keep the welder secure and prevent it from tipping over or falling.

#### 1.2 Your Welder's Condition

- Check all cables, power cord and welding cable to be sure the insulation is not damaged. Always replace or repair damaged components before using the welder.
- Check all components to ensure they are clean and in good operating condition before use.

### 1.3 Use of Your Welder

#### **▲ CAUTION**

- Do not operate the welder if the output cable/electrode holder, ground cable/clamp or electrode is wet. Do not immerse them in water. These components and the welder must be completely dry before attempting to use them.
- Follow the instructions in this manual.
- Keep welder in the off position when not in use.
- Connect ground lead/clamp as close to the area being welded as possible to ensure a good ground.
- Do not allow any body part to come in contact with the welding electrode if you are in contact with the material being welded, ground or electrode from another welder.
- Do not weld if you are in an awkward position. Always have a secure stance while welding to prevent accidents. Wear a safety harness if working above ground.
- Do not drape cables over or around your body.
- Wear a full coverage helmet with appropriate shade (see ANSI Z87.1 safety standard) and safety glasses while welding.
- Wear proper gloves and protective clothing to prevent your skin from being exposed to hot metals, UV and IR rays.
- Do not overuse or overheat your welder. Allow proper cooling time between duty cycles.
- Keep hands and fingers away from moving parts.
- Do not point electrode at any body part of yourself or anyone else.

## GENERAL PRODUCT INFORMATION

-Always use this welder in the rated duty cycle to prevent excessive heat and failure.

### 1.4 Specific Areas of Danger, Caution or Warning



#### Electrical Shock

##### **▲ WARNING**

Electric arc welders can produce a shock that can cause injury or

death. Touching electrically live parts can cause fatal shocks and severe burns. While welding, all metal components connected to the electrode are electrically hot. Poor ground connections are a hazard, so secure the ground lead before welding.

-Wear dry protective apparel: coat, shirt, gloves and insulated footwear.  
-Insulate yourself from the work piece. Avoid contacting the work piece or ground.

- Do not attempt to repair or maintain the welder while the power is on.

-Inspect all cables and cords for any exposed wire and replace immediately.

-Use only recommended replacement cables and cords.

-Always attach ground clamp to the work piece or work table as close to the weld area as possible.

-Do not touch the welding electrode and the ground or grounded work piece at the same time.

-Do not use a welder to thaw frozen pipes.

#### Fumes and Gases

##### **▲ WARNING**

-Fumes emitted from the welding process displace clean air and can result in

injury or death.



-Do not breathe in fumes emitted by the welding process. Make sure your breathing air is clean and safe.

-Work only in a well-ventilated area or use a ventilation device to remove welding fumes from the environment where you will be working.

-Do not weld on coated materials (galvanized, cadmium plated or containing zinc, mercury or barium). They will emit harmful fumes that are dangerous to breathe. If necessary use a ventilator, respirator with air supply or remove the coating from the material in the weld area.

-The fumes emitted from some metals when heated are extremely toxic. Refer to the material safety data sheet for the manufacturer's instructions.

-Do not weld near materials that will emit toxic fumes when heated. Vapors from cleaners, sprays and degreasers can be highly toxic when heated.

#### UV and IR Arc Rays

##### **▲ DANGER**

The welding arc produces ultraviolet (UV) and infrared (IR) rays

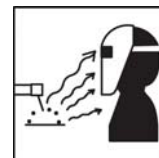

that can cause injury to your eyes and skin. Do not look at the welding arc without proper eye protection.

-Always use a helmet that covers your full face from the neck to top of head and to the back of each ear.

-Use a lens that meets ANSI standards and safety glasses. For welders under 160 Amps output, use a shade 10 lens; for above 160 Amps, use a shade 12. Refer to the ANSI standard Z87.1 for more information.

-Cover all bare skin areas exposed to the arc with protective clothing and shoes. Flame-retardant cloth or

## GENERAL PRODUCT INFORMATION

leather shirts, coats, pants or coveralls are available for protection.

- Use screens or other barriers to protect other people from the arc rays emitted from your welding.
- Warn people in your welding area when you are going to strike an arc so they can protect themselves.



### Fire Hazards

#### **▲ WARNING**

Do not weld on containers or pipes that contain or have had flammable,

gaseous or liquid combustibles in them. Welding creates sparks and heat that can ignite flammable and explosive materials.

- Do not operate any electric arc welder in areas where flammable or explosive materials are present.
- Remove all flammable materials within 35 feet of the welding arc. If removal is not possible, tightly cover them with fireproof covers.
- Take precautions to ensure that flying sparks do not cause fires or explosions in hidden areas, cracks or areas you cannot see.
- Keep a fire extinguisher close in the case of fire.
- Wear garments that are oil-free with no pockets or cuffs that will collect sparks.
- Do not have on your person any items that are combustible, such as lighters or matches.
- Keep work lead connected as close to the weld area as possible to prevent any unknown, unintended paths of electrical current from causing electrical shock and fire hazards.
- To prevent any unintended arcs, keep electrode away from grounded materials until you are ready to weld.



### Hot Materials

#### **▲ CAUTION**

Welded materials are hot and can cause severe burns if handled

improperly.

- Do not touch welded materials with bare hands.
- Do not touch electrode after welding until it has had time to cool down.

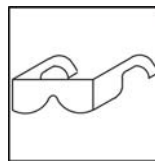

### Sparks/Flying Debris

#### **▲ CAUTION**

Welding creates hot sparks that can cause injury. Chipping slag off

welds creates flying debris.

- Wear protective apparel at all times: ANSI-approved safety glasses or shield, welder's hat and ear plugs to keep sparks out of ears and hair.



### Electromagnetic Field

#### **▲ CAUTION**

-Electromagnetic fields can interfere with various electrical and electronic

devices such as pacemakers.

- Consult your doctor before using any electric arc welder or cutting device
- Keep people with pacemakers away from your welding area when welding.
- Do not wrap cable around your body while welding.
- Wrap MIG gun and ground cable together whenever possible.
- Keep electrode cable/holder and ground cables on the same side of your body.

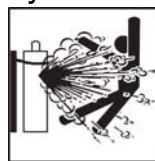

### Shielding Gas Cylinders Can Explode

#### **▲ WARNING**

High pressure cylinders can explode if damaged, so treat them carefully.

## GENERAL PRODUCT INFORMATION

- Never expose cylinders to high heat, sparks, open flames, mechanical shocks or arcs.
- Do not touch cylinder with electrode
- Do not weld on the cylinder.
- Always secure cylinder upright to a cart or stationary object
- Keep cylinders away from welding or electrical circuits.
- Use the proper regulators, gas hose and fittings for the specific application.
- Do not look into the valve when opening it
- Use protective cylinder cap whenever possible

### 1.5 Proper Care, Maintenance and Repair

#### **⚠ DANGER**

- Repair to internal component should only be done by a qualified repair center.
- Always have power disconnected when working on internal components.
- Do not touch or handle PC board without being properly grounded with a wrist strap. Put PC board in static proof bag to move or ship.
- Do not put hands or fingers near moving parts such as a fan

### Assembly

No assembly is required for this unit.

## Installation

### 1. Power requirement

This welder uses AC single phase 120v , 60HZ/20amp time delayed fuse or circuit breaker. **DO NOT OPERATE THIS UNIT** if the **ACTUAL** power source voltage is less than 105 volts ac or greater than 132 volts ac.

#### **⚠ WARNING**

- **High voltage danger from power source! Consult a qualified electrician for proper installation of receptacle. This welder must be grounded while in use to protect the operator from electrical shock.**
- **Do not remove grounding prong or alter the plug in any way. Do not use any adapters between the welder's power cord and the power source receptacle. Make sure the POWER switch is OFF when connecting your welder's power cord to a properly grounded 115 Vac, 60Hz, single phase, 20 amp power source.**

### 2. Extension cord

It is strongly recommended that an extension cord should not be used because of the voltage drop it produces. This drop in voltage can affect the performance of the welder. If you need to use an extension cord it must be a #12 gauge cord or larger. Do not use an extension cord over 25 ft. in length.

### 3. Setting up the work piece

#### 3.1 Welding positions

There are four basic positions for welding: Flat, Horizontal, vertical and overhead. Flat welding is generally easier, faster, and allows for better penetration. If possible, the work piece should be positioned so that the bead will run on a flat surface.

#### 3.2 Preparing the Joint

Before welding, the surface of work piece needs to be free of dirt, rust, scale, oil or paint or it will create brittle and porous weld. If the base metal pieces to be joined are thick or heavy, it may be necessary to bevel the edges with a metal grinder, the



## GENERAL PRODUCT INFORMATION

correct bevel should be around 60 degree. See following picture:

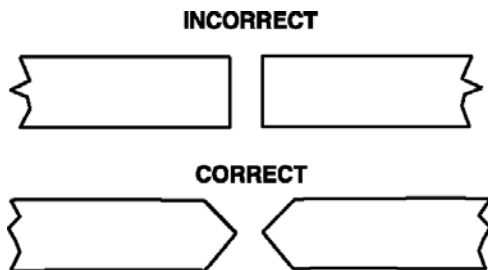

Based on different welding position, there are different welding joint, see following images for more information

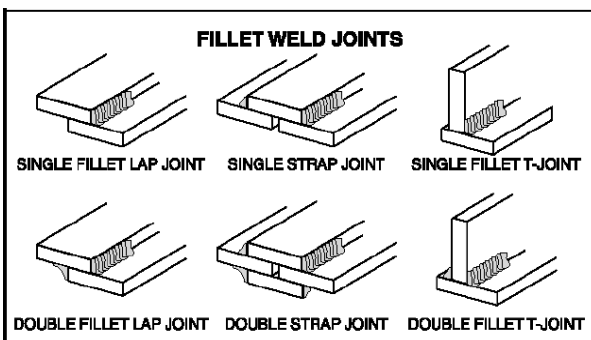
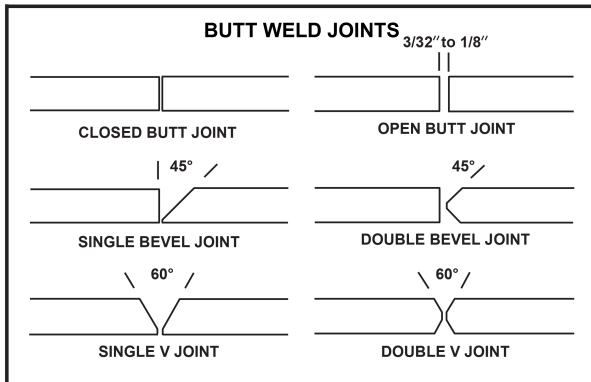

### 4. Ground clamp connection

Clear any dirt, rust, scale, oil or paint on the ground clamp. Make certain you have a good solid ground connection. A poor connection at the ground clamp will waste power and heat. Make sure the ground clamp touches the metal.

### 5. Electrode

The welding electrode is a rod coated with a layer of flux. When welding, electrical current flows between the electrode (rod) and the grounded metal work piece. The intense heat of the arc between the rod and the grounded metal melts the electrode and the flux. The most popular electrodes are:

- E6011 60,000 PSI tensile strength deep penetrating applications.
- E6013 60,000 PSI tensile strength used for poor fit up applications
- E7014 70,000 PSI tensile strength used for high deposition and fast travel speeds with light penetration
- E7018AC 70,000 PSI tensile strength, Used for out of position and tacking.

### 6. Selecting the proper electrode

The type and thickness of metal and the position of the work piece determine the electrode type and the amount of heat needed in the welding process. Heavier and thicker metals required more amperage. It is best to practice your welds on scrap metal which matches the metal you intend to work with to determine correct heat setting and electrode choice. See the following helpful trouble shooting tips to determine if you are using a correct electrode

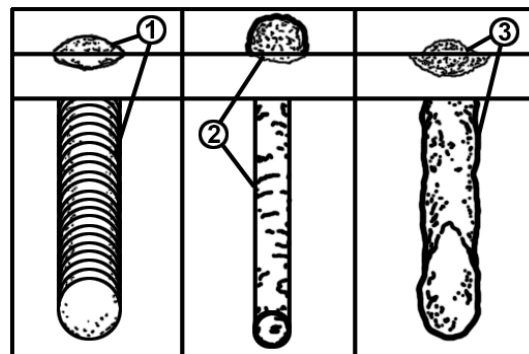

1. When proper rod is used:

## GENERAL PRODUCT INFORMATION

- a. The bead will lay smoothly over the work without ragged edges
  - b. The base metal puddle will be as deep as the bead that rises above it
  - c. The welding operation will make a crackling sound similar to the sound of bacon frying
2. When a rod too small is used:
    - a. The bead will be high and irregular
    - b. The arc will be difficult to maintain
  3. When the rod is too large
    - a. The arc will burn through light metals
    - b. The bead will undercut the work
    - c. The bead will be flat and porous
    - d. Rod may be freeze or stick to work piece

**Note:** Rate of travel over the work also affects the weld. To ensure proper penetration and enough rod deposit, the arc must be moved slowly and evenly along the weld seam.

### Operation

#### 1. Setting the amperage control

The welder has a two step output current control. It is capable of welding with 1/16" and 5/64" electrodes.

Use MIN setting for 1/16" electrodes and MAX for 5/64" electrodes. It is best to practice your welds on scrap metal which matches the metals you intend to work with to determine correct setting for your job. The electrode type and the thickness of the work piece metal determine the amount of heat needed in the welding process. Heavier and thicker metals require more voltage (amperage),

whereas lighter and thinner metals require less voltage (amperage).

#### 2. Welding techniques

The best way to teach yourself how to weld is with short periods of practice at regular intervals. All practice welds should be done on scrap metal that can be discarded. Do not attempt to make any repairs on valuable equipment until you have satisfied yourself that your practice welds are of good appearance and free of slag or gas inclusions.

##### 2.1 Holding the electrode

The best way to grip the electrode holder is the way that feels most comfortable to you. Position the Electrode to the work piece when striking the initial arc it may be necessary to hold the electrode perpendicular to the work piece. Once the arc is started the angle of the electrode in relation to the work piece should be between 10 and 30 degrees. This will allow for good penetration, with minimal spatter.

##### 2.2 Striking the arc

#### **▲ WARNING**

**EXPOSURE TO A WELDING ARC IS EXTREMELY HARMFUL TO THE EYES AND SKIN.**

- **Never strike an arc or begin welding until you have adequate protection.**
- **Wear flameproof welding gloves, heavy long-sleeved shirt, trousers with out cuffs, high-topped shoes and a welding helmet or shield.**

Scratch the work piece with the end of electrode to start arc and then raise it quickly about 1/8 inch gap between the rod and the work piece, see following picture

## GENERAL PRODUCT INFORMATION

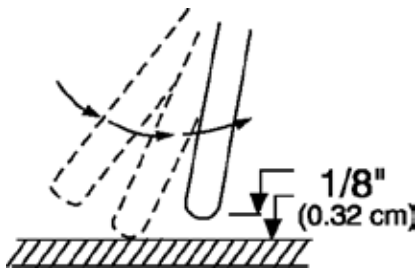

It is important that the gap be maintained during the welding process and it should be neither too wide or too narrow. If too narrow, the rod will stick to the work piece. If too wide, the arc will be extinguished. It needs much practice to maintain the gap. When the rod sticks to the work piece, gently rock it back and forth to separate them. A stuck electrode will cause a short circuit and the circuit breaker of thermal overload will shut the welder off. A good arc is accompanied by a crisp, cracking sound. The sound is similar to that made by bacon frying. To lay a weld bead, only 2 movements are required; downward and in the direction the weld is to be laid, as in following figure:

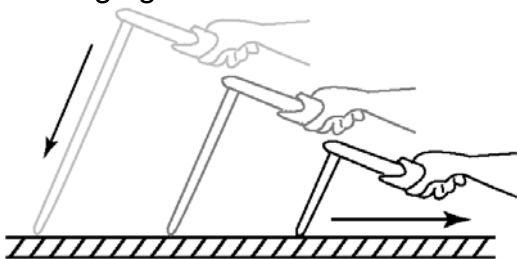

### 2.3 Types of weld bead

The following paragraphs discuss the most commonly used arc welding beads.

**The stringer bead** Formed by traveling with the torch in a straight line while keeping the wire and nozzle centered over the weld joint.

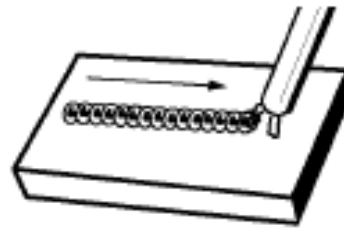

**The weave bead** Used when you want to deposit metal over a wider space than would be possible with a stringer bead. It is made by weaving from side to side while moving with the torch. It is best to hesitate momentarily at each side before weaving back the other way penetration.

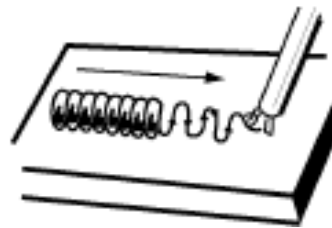

### 2.4 Welding position

**Flat position** It is easiest of the welding positions and is most commonly used. It is best if you can weld in the flat position if at all possible as good results are easier to achieve.



**The horizontal position** it is performed very much the same as the flat weld except that the angle is different such that the electrode, and therefore the arc force, is directed more toward the metal above the weld joint. This more direct angle helps prevent the weld puddle from running downward while still allowing slow enough travel speed to achieve

## GENERAL PRODUCT INFORMATION

good penetration. A good starting point for your electrode angle is about 30 degrees DOWN from being perpendicular to the work piece.

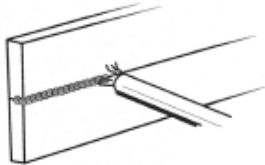

### 2.5 Judging a good weld bead

When the skill of striking and holding an arc has been learned, the next step is learning how to run a good bead. The first attempts in practice will probably fall short of acceptable weld beads. Too long of an arc will be held or the travel speed will vary from slow to fast (see following)

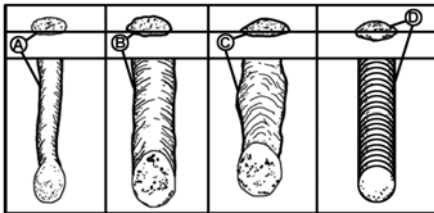

- A. Weld speed is too fast.
- B. Weld speed is too slow.
- C. Arc is too long.
- D. Ideal weld.

A solid weld bead requires that the electrode be moved slowly and steadily along the weld seam. Moving the electrode rapidly or erratically will prevent proper fusion or create a lumpy, uneven bead. To prevent ELECTRIC SHOCK, do not perform any welding while standing, kneeling, or lying directly on the grounded work.

### 2.6 Finish the bead

As the coating on the outside of the electrode burns off, it forms an covering of protective gasses around the weld. This prevents air from reaching the molten metal and creating an undesirable chemical

reaction. The burning coating, however, forms slag. The slag formation appears as an accumulation of dirty metal scale on the finished weld. Slag should be removed using a chipping hammer.

### **▲ WARNING**

**CHIPPING THE SLAG FROM A WELD JOINT CAUSES SMALL CHIPS OF SLAG TO FLY THROUGH THE AIR**

- *Slag flying through the air can cause eye injury or injury to parts of the head, hands or exposed portions of the body.*
- *Wear goggles or eye glasses with side shields and protect the hands and other exposed parts of the body with protective garments, or if possible, work with a shield between the body and the work piece.*

The intense heat produced at the arc sets up strains in the metal joined by welding. Chipping the weld not only removes the slag left behind in the welding but relieves the internal strains developed by the heating and cooling process.

## Maintenance

The welder needs regular maintenance.

Periodically clean dust, dirt, grease, etc. from your welder. Every six months, or as necessary, remove the cover panel from the welder and air-blow any dust and dirt that may have accumulated inside the welder.

Replace power cord, ground cable, ground clamp, or electrode assembly when damaged or worn.

## MINOR AND ROUTINE MAINTENANCE

## GENERAL PRODUCT INFORMATION

The welder should not be exposed to rain or high humidity. Store in a clean dry location free from corrosive gas, dust and high humidity. Temperature ranges from 10° F – 120°F and a relative humidity less than 90%.

When transporting or storing the welder after use, it is recommended to repack the product as it was received for protection. (Cleaning is required before storage and you must seal the plastic bag in the box for storage)

### Trouble shooting Chart

Symptom (s)	Possible Causes(s)	Corrective Action(s)
Welder does not work when the turn on the main switch	<ol style="list-style-type: none"> <li>1. No power input</li> <li>2. The power cord or power plug is broken</li> <li>3. Main switch is broken</li> <li>4. Transformer is broken</li> </ol>	<ol style="list-style-type: none"> <li>1. Check circuit or fuse of power source</li> <li>2. Replace power cord</li> <li>3. Replace switch</li> <li>4. Replace the transformer</li> </ol>
Welder does not weld properly	<ol style="list-style-type: none"> <li>1. Incorrect power input</li> <li>2. Inadequate current at output</li> <li>3. Poor connection of output cable</li> <li>4. Dirty surfaces</li> <li>5. Wrong welding wire</li> </ol>	<ol style="list-style-type: none"> <li>1. Check the power source</li> <li>2. Check for proper grounding to the work piece.</li> <li>3. Check output connection</li> <li>4. Clean surfaces</li> <li>5. Use correct wire</li> </ol>
Welder blows circuit breaker or fuse	Wrong circuit breaker or fuse in power supply	Check the circuit breaker or fuse in power source should be 20amp
Arc is hard to start	<ol style="list-style-type: none"> <li>1. The wrong electrode, too big</li> <li>2. Base metal not grounded properly</li> </ol>	<ol style="list-style-type: none"> <li>1. Use correct electrode</li> <li>2. Make sure the connection is good</li> </ol>
Welding bead too thin	The welding speed is too fast	Slow down the welding speed
Welding bead too thick	The welding speed is too slow	Speed up the welding speed
Electrode sticks to work piece	Electrode is kept to contact work piece too long time when starting arc	After arc starting, move the electrode away from the work piece immediately
Poor welding performance, spatter	<ol style="list-style-type: none"> <li>1. Damp electrode</li> <li>2. Wrong type electrode</li> </ol>	use dry electrode use correct electrode
Others		Call Tech Help

# GENERAL PRODUCT INFORMATION

## Main Circuit Chart

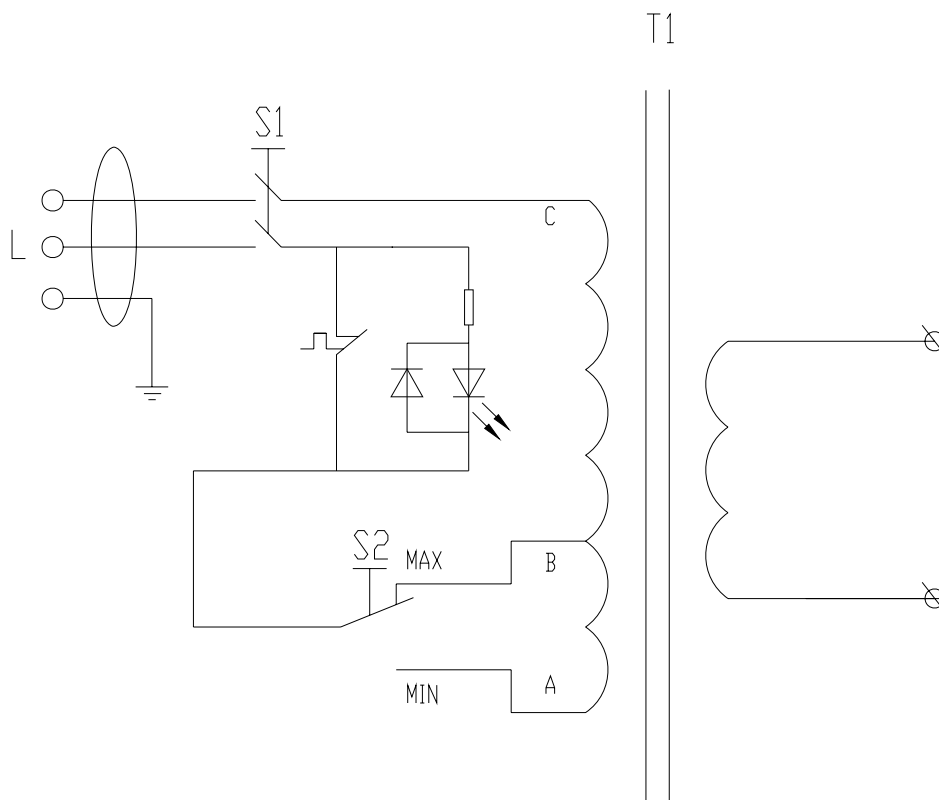

## GENERAL PRODUCT INFORMATION

### Illustrated Parts List

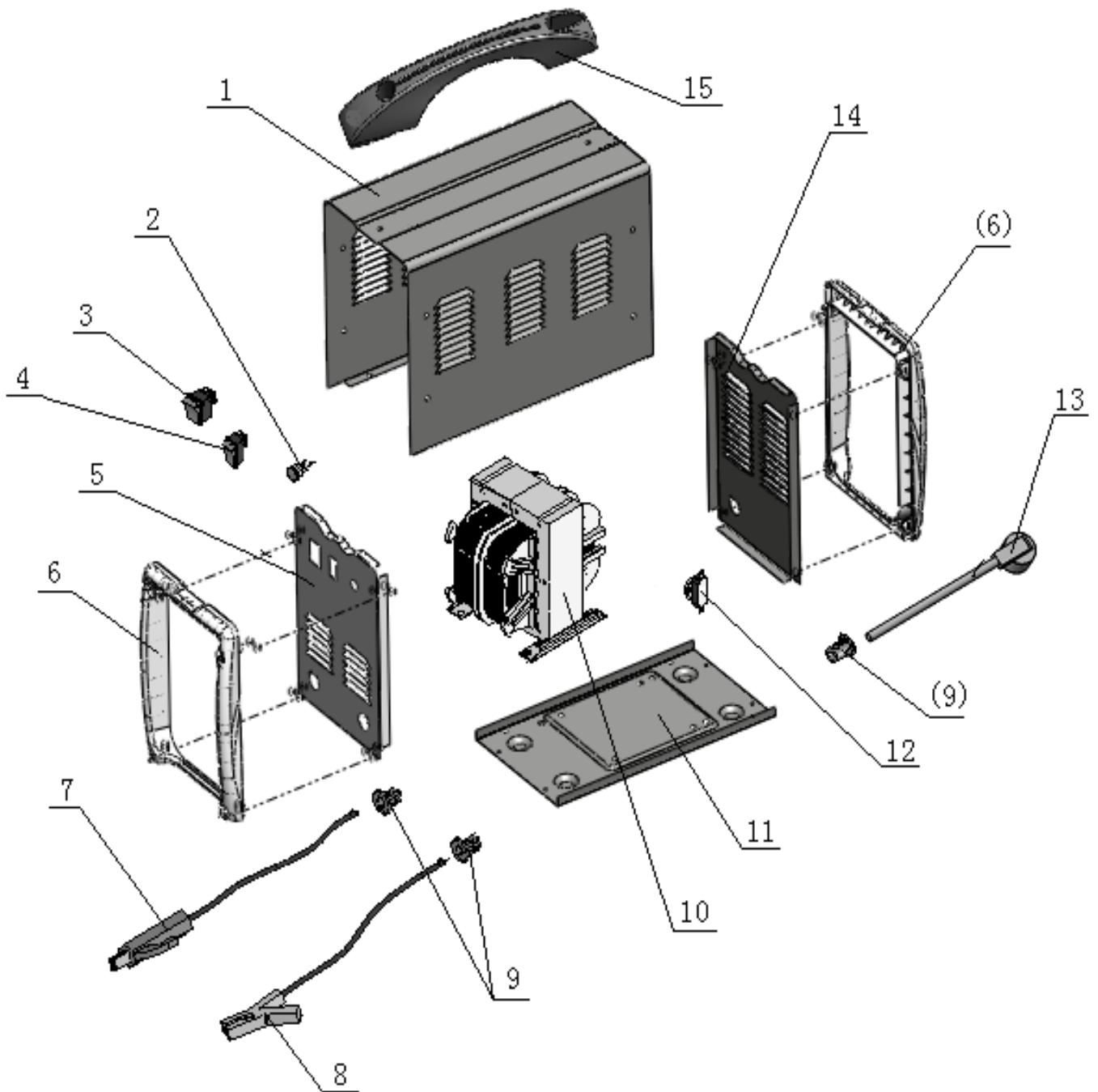

## GENERAL PRODUCT INFORMATION

### Repair Parts List

NO.	PART	NAME	QTY
1	1.1.01.01.0061	Case	1
2	2.07.28.211	Thermal Overload indicator	1
3	2.07.80.221	Power Switch	1
4	2.07.80.031	Voltage Selector	1
5	1.1.01.03.0061	Front Panel	1
6	2.05.05.035	Plastic Frame	2
7	1.2.08.01.0034	Electrode Holder and Cable	1
8	1.2.08.02.0046	Ground Cable/Clamp	1
9	2.05.05.201	Cable Holder	3
10	1.1.04.01.1603	Transformer	1
11	1.1.01.04.0042	Lower Panel	1
12	2.07.36.740	Thermostat	1
13	2.03.05.140	Power Cord with Plug	1
14	1.1.01.03.0062	Rear Panel	1
15	2.05.08.115	Handle	1