

# **OWNER'S MANUAL & INSTALLATION GUIDE**



**READ ENTIRE INSTALLATION GUIDE  
PRIOR TO INSTALLING THE BATHTUB  
THIS BATHTUB SHOULD ONLY BE  
INSTALLED BY A CERTIFIED PLUMBER**

**CAUTION!**



**TWO PEOPLE ARE REQUIRED  
TO LIFT THE BATHTUB**

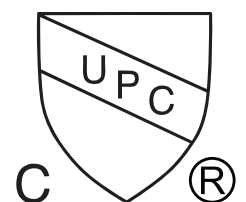

**QUESTIONS ON PRODUCT, INSTALLATION, RETURNS? PLEASE CONTACT**

# WARRANTY

## **RETURNS**

We thank you for your purchase. Here at Streamline®, our goal is to provide customers with exceptional bathroom and kitchen products. We understand that things sometimes don't work out. If you are unsatisfied with your Streamline® product and would like to initiate a return, please reach out to support@streamlinebath.com. We continue to grow and want to offer the best customer experience possible, and by reaching out to us prior to initiating a return, we can ensure that these issues do not continue in the future.

## **LIMITED WARRANTY EXCLUSION**

ALL OTHER WARRANTIES EXPRESS OR IMPLIED INCLUDING ALL IMPLIED WARRANTIES OF MERCHANTABILITY OF FITNESS FOR A PARTICULAR PURPOSE ARE HEREBY DISCLAIMED. STREAMLINE IS NOT LIABLE FOR ANY INDIRECT, INCIDENTAL, CONSEQUENTIAL OR SIMILAR DAMAGES INCLUDING, BUT NOT LIMITED TO, LOST PROFITS OR REVENUE, INABILITY TO USE THE PRODUCT, OR ANY OTHER ASSOCIATED EQUIPMENT, THE COST OF SUBSTITUTE EQUIPMENT, AND ANY CLAIMS BY THIRD PARTIES RESULTING FROM THE USE OF THIS PRODUCT.

This warranty gives you specific legal rights, and you may have other rights that vary from state to state. Some states do not allow the exclusion or limitation of incidental or consequential damages, so the limitations or exclusions stated above may not apply.

## **WHAT IS NOT COVERED UNDER THIS LIMITED WARRANTY**

- Normal wear and tear or cosmetic damage.
- Damage due to accidents, misuse, physical force, improper installation or operation, mishandling, neglect, fire, heat, water, humidity, liquids, insect infestation, or other intrusion.
- Products that have been repaired, altered or modified by anyone other than Streamline® or its authorized service representative.
- Damage caused by use of non-Streamline® accessories or misapplication.
- Products whose serial numbers have been removed, altered or rendered illegible.
- Products purchased, shipped from, used or serviced outside the United States.
- Damage caused by acts of nature such as, but not limited to, lightning damage.
- Products returned without valid proof of purchase.

## **DELIVERIES**

Immediate inspection is required when receiving Streamline® items. It is important to notate any damage or carton count discrepancy on the BOL / Proof of Delivery (POD) receipt when you sign for the delivery, even if the package appears only slightly damaged. If the driver doesn't allow or won't wait, notate on the BOL / POD "Driver will not allow inspection." Damages should be reported to Streamline® within 3 calendar days of delivery.

Customers who sign for delivery and do not provide proper detailed description assume responsibility if merchandise is damaged or missing cartons. If the product itself appears significantly damaged, you may refuse delivery after you notate it on the POD / BOL and provide clear pictures to Streamline®. Please notify Streamline® of refusal so we can anticipate the return and send out a new item.

Please look for the following when checking:

- Carton/Pallet Count
- Crumpled and pushed in areas
- Fork lift punctures
- Holes
- Any additional outside damage to packaging

## **ESTIMATED SHIPPING & TRANSIT TIME**

We do our best to provide you with accurate shipping times for our products. The times are estimates only. Estimated transit time will not include the time it takes for the item to be processed. Products that are in stock normally ship from the warehouse within 1-2 business days, however these products are subject to prior sale and availability and lead times are not guaranteed.

Estimated shipping time is between 2-10 business days (the actual number will depend on the state and customer availability for delivery). These shipping times are not guaranteed. If you have a time sensitive project we recommend that you contact a customer service representative at support@streamlinebath.com.

## **DAMAGE & DEFECTIVE GOODS POLICY**

At Streamline®, we understand that a product may get damaged in transit or, on occasion, there may be a manufacturer product defect. Rest assured, we will stand behind you during this process and make sure we do everything we can to bring it to a satisfying and timely conclusion.

For us to offer this level of service, however, we need a little help from the customer in the form of a detailed product inspection immediately upon delivery. In this case, it is important to notate any damage on the BOL or POD when you sign for the delivery. Also, please provide clear photos of the damages to Streamline®. If the driver doesn't allow or won't wait notate on the BOL / POD "Driver will not allow inspection." All damages should be reported to Streamline® within 3 calendar days of delivery.

## **REPLACEMENT PARTS**

Replacement parts are sent at Streamline's® sole discretion. For us to determine if replacement parts are necessary, please provide us with a clear description of what the issue is as well as supplementary photos for us to better serve you and understand the problem. Whether any additional fees or charges are to be assessed with respect to replacement parts will be determined on a case by case basis.

## **INCORRECTLY SHIPPED ITEMS**

If the item received was incorrectly shipped or missing any component parts, please contact us immediately at support@streamlinebath.com

## **DAMAGES & REFUSING A FREIGHT SHIPMENT**

If the shipment is damaged, a customer has the option of refusing the shipment. Contact our customer service representative immediately at support@streamlinebath.com when and if you refuse a shipment. Also, proper notation must be on the BOL / POD receipt.

Any external evidence of loss or damage that occurred during transit is considered visible loss or damage and must be noted on the BOL / POD and signed by the carrier's agent (driver). Failure to adequately describe the visible loss or damage could result in the carrier delaying or refusing to honor the freight claim.

Any damage that occurred during transit that was not visible at the time of delivery is considered concealed loss or damage. Due to rough handling in transit it is possible to damage the contents of a carton without damaging the outer packaging itself. If such a situation occurs, it is important to contact Streamline® immediately for instructions on how to handle this.

You must open all received boxes and inspect products for concealed damage within 72 hours (3 calendar days) of delivery and Streamline® must be notified at that time. After this time frame claims may not be honored.

Streamline® reserves the right to replace any damaged merchandise within 3 calendar days of notification by the customer. If a replacement item is available for shipping within that time period, then a refund cannot be issued. If no replacement is available, the damaged item(s) will be refunded in full if the damage was the fault of freight carrier, and all return procedures were followed.

Failure to follow return procedure for the damaged item may result in a charge for the free replacement item.

## **LIMITED MANUFACTURER'S WARRANTY [BATHTUB]**

All parts and finishes of Streamline® bathtubs are warranted to the original consumer purchaser to be free from defects in material and workmanship for a period of two to five years [depending on model; please check the product listing or email us at support@streamlinebath.com] after the date of original retail purchase. Proof of the original purchase is required to obtain a remedy under this limited warranty. Streamline® recommends using a professional plumber for all installation and repair.

Streamline® will replace, free of charge, during the warranty period any part or finish that proves defective in material and/or workmanship under normal installation, use and service. Replacement parts may be obtained by emailing us at support@streamlinebath.com

This warranty is extensive in that it covers replacement of all defective parts and even finish, but these are the only two things that are covered. Labor charges and/or damage incurred in installation, repair, or replacement as well as any other kind of loss or damages are excluded. Proof of purchase (original sales receipt) from the original consumer purchaser must be made available to Streamline® for all warranty claims. This is the exclusive warranty by Streamline®, which does not make any other warranty of any kind, including the implied warranty of merchantability.

This warranty excludes all industrial, commercial and business usage, whose purchasers are hereby extended a one-year limited warranty from the date of purchase, with all other terms of this warranty applying except the duration of the warranty.

Any damage to this faucet as a result of misuse, abuse, or neglect, or any use of other than genuine Streamline® replacement parts will void the warranty.

## **LIMITED MANUFACTURER'S WARRANTY [FAUCETS]**

All parts and finishes of Streamline® faucets are warranted to the original consumer purchaser to be free from defects in material and workmanship for three years from date of purchase. Streamline® recommends using a professional plumber for all installation and repair.

Streamline® will replace, free of charge, during the warranty period any part or finish that proves defective in material and/or workmanship under normal installation, use and service. Replacement parts may be obtained by emailing us at support@streamlinebath.com

This warranty is extensive in that it covers replacement of all defective parts and even finish, but these are the only two things that are covered. Labor charges and/or damage incurred in installation, repair, or replacement as well as any other kind of loss or damages are excluded. Proof of purchase (original sales receipt) from the original consumer purchaser must be made available to Streamline® for all warranty claims. This is the exclusive warranty by Streamline®, which does not make any other warranty of any kind, including the implied warranty of merchantability.

This warranty excludes all industrial, commercial and business usage, whose purchasers are hereby extended a one year limited warranty from the date of purchase, with all other terms of this warranty applying except the duration of the warranty.

Any damage to this faucet as a result of misuse, abuse, or neglect, or any use of other than genuine Streamline® replacement parts will void the warranty.

# PRIOR TO INSTALLING

These products must be installed by a fully insured and licensed plumber only.

Installation of any product by anyone other than fully insured and licensed plumber shall void limited warranty.

We are not responsible for any local code compliance for this product.

Building and plumbing codes may vary state-to-state.

Streamline shall not be held liable for any and all incidental damages or flood caused due to use of this product.

Streamline shall not be held liable for any and all fees stemming from cost of installation, re-installation, removal, subsequent damage, or transportation in a case of a product defect.

# TOOLS REQUIRED

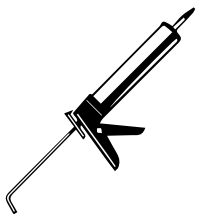

Silicone



Pencil



Adjustable Key

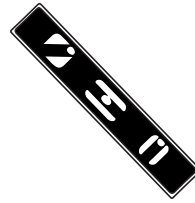

Level Bar



Measuring Tape

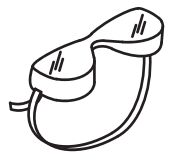

Safety Glasses

# WHAT'S IN THE BOX

Please note:

Different bathtub models have different drain models. Please see the next page to determine which drain model applies to the bathtub model that you have purchased.

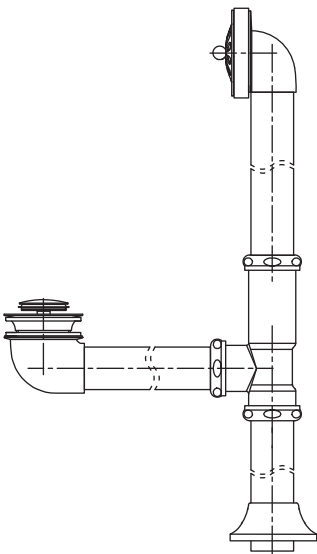

N-DWF-CH  
N-DWF-GLD

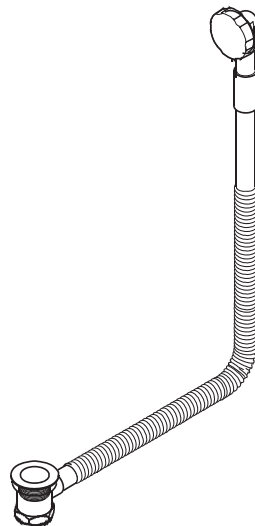

(Pre-installed)  
Model A1866

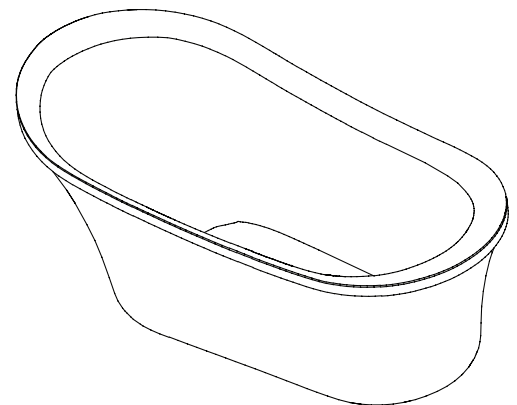

Bathtub

# DRAIN MODEL COMPATIBILITY

## ACRYLIC FREESTANDING BATHTUB

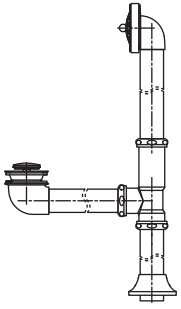

N-DWF-CH  
N-DWF-GLD



R-5040-67CIFS BCH-FM



R-5041-67CIFS PCH-FM



R-5042-67CIFS WH-FM



R-5043-67CIFS R DY-FM



R-5080-66CIFS WH-FM



R-5081-60CIFS WH-FM



R-5140-66CIFS WH-FM



R-5180-72CIFS WH-FM



R-5200-72CIFS WH-FM



R-5201-61CIFS WH-FM



R-5300-71CIFS WH-FM



R-5320-67CIFS GR-FM



R-5340-66CIFS GLD-FM



R-5360-72CIFS B CH-FM



R-5380-67CIFS GLD-FM



R-5381-67CIFS B CH-FM

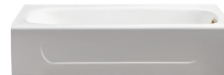

R-5480-60CIFS AL WH-FM

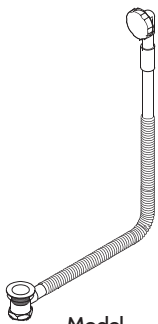

Model  
Model A1866



R-5260-67CIFS GLD-FM



R-5400-67CIFS WH-FM

# DRAIN DIAGRAMS

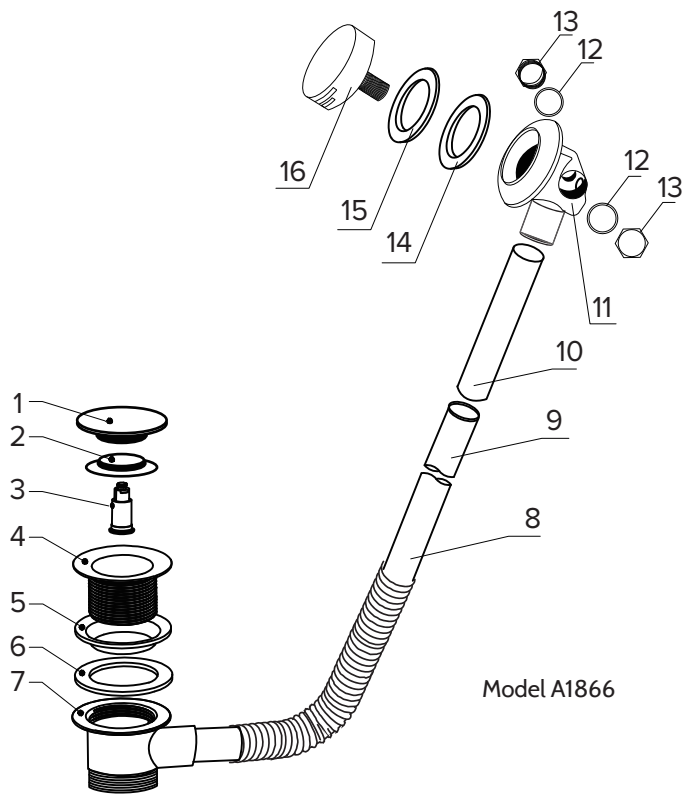

Model A1866

No	ITEM	Qty
1	Cover	1
2	Cover gasket	1
3	Cartridge	1
4	Strainer	1
5	Waste upper gasket	1
6	Waste lower gasket	1
7	Connector	1
8	Coupling nut	1
9	Nut	1
10	Washer	3
11	Tee	3
12	Pipe	1
13	Overflow body	1
14	Tapered rubber gasket	1
15	Overflow upper gasket	1
16	Overflow plate	1
17	Pin Bolt	1
16	Taic piece	1
17	Flange	1

# DRAIN DIAGRAMS

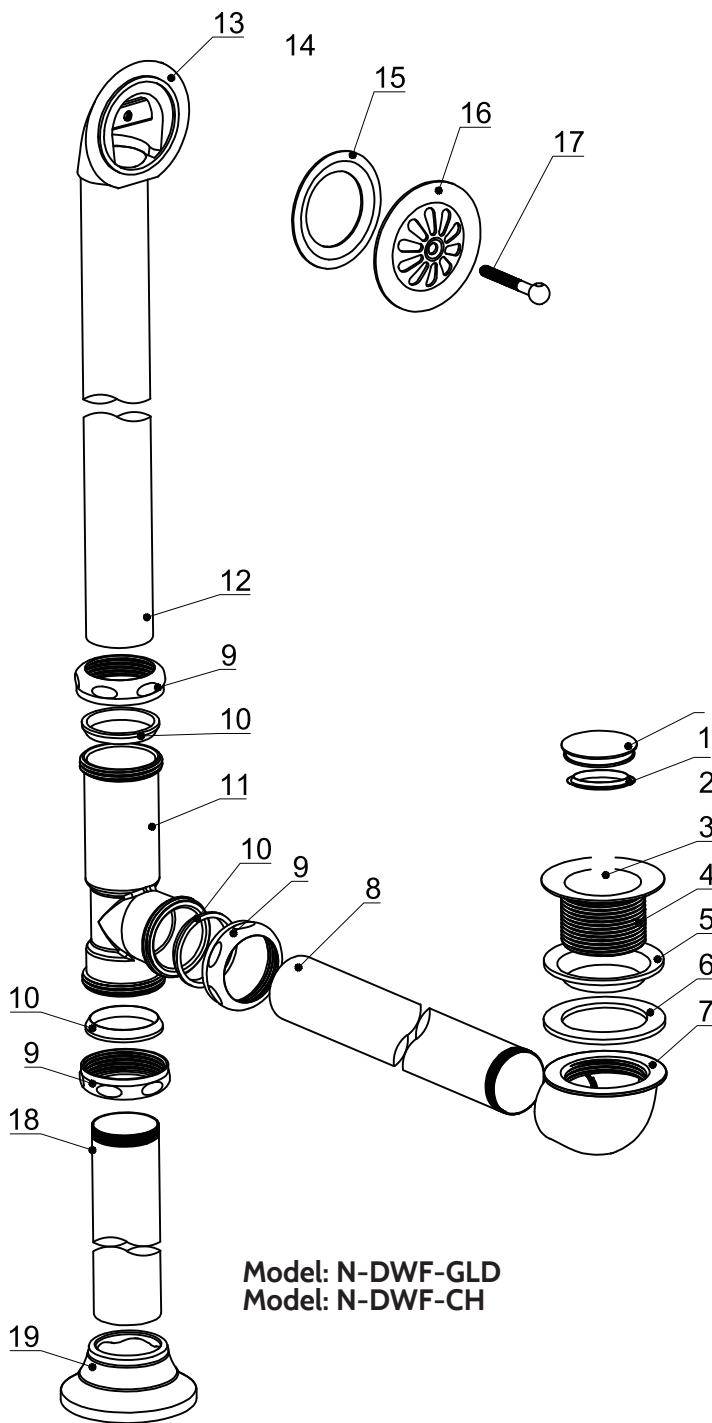

No	ITEM	Qty
1	Cover	1
2	Cover gasket	1
3	Cartridge	1
4	Strainer	1
5	Waste upper gasket	1
6	Waste lower gasket	1
7	Connector	1
8	Coupling nut	1
9	Nut	1
10	Washer	3
11	Tee	3
12	Pipe	1
13	Overflow body	1
14	Tapered rubber gasket	1
15	Overflow upper gasket	1
16	Overflow plate	1
17	Pin Bolt	1
16	Taic piece	1
17	Flange	1

# BATHTUB INSTALLATION

1. Ensure that the floor at the installation site has sufficient floor support and is level.

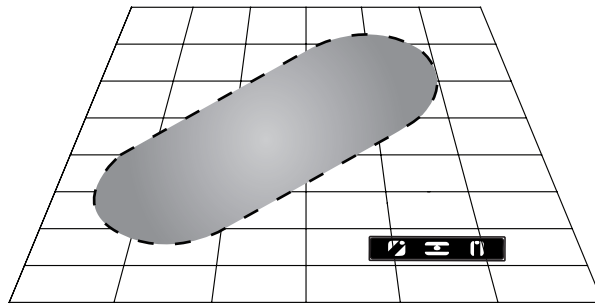

2. Waterproofing the floor is highly recommended.

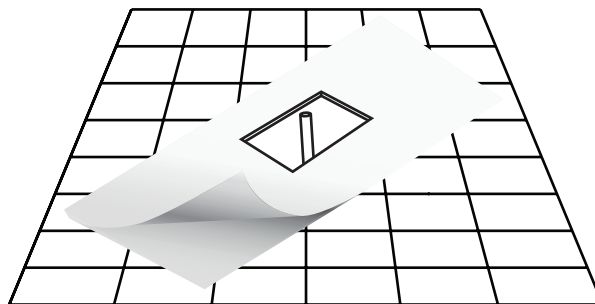

3. Determine the location of the drainpipe on the floor by taking measurements of the drain and waste location underneath the unit. Clean the drain hole area in preparation of setting the drain. The area should be dry & free from any debris.

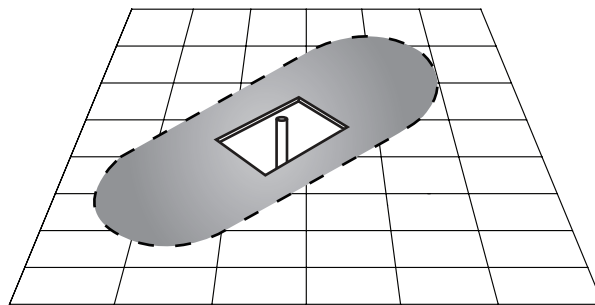

4. Remove the bathtub from its box. It is recommended that the bathtub is carried by a minimum of two people. Ensure to carry and set down the bathtub only in the upside-down position.

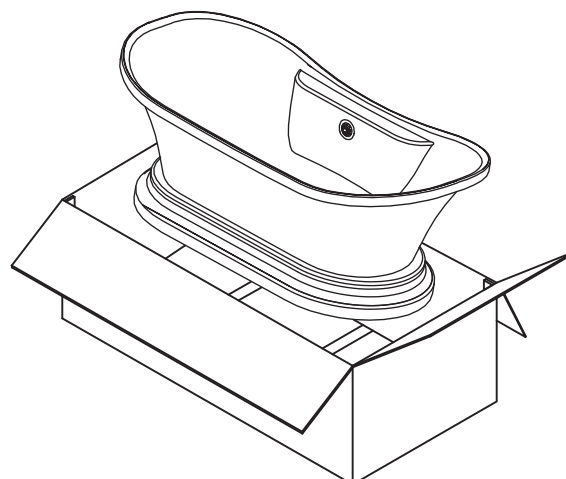

5. Gently place the bathtub in the upside-down position on a tarp or cardboard sheet in order to avoid contact with any rough surface.

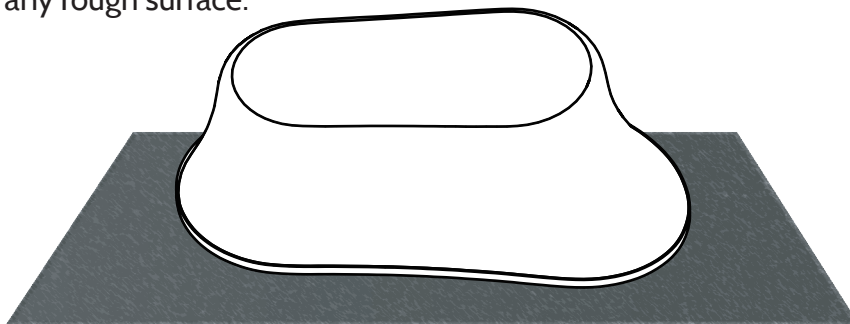

6. Loosen the nuts & washers from the metal frame. Adjust the leveling feet to align with the bathtub's bottom as well as the floor and then tighten the washer and nuts.

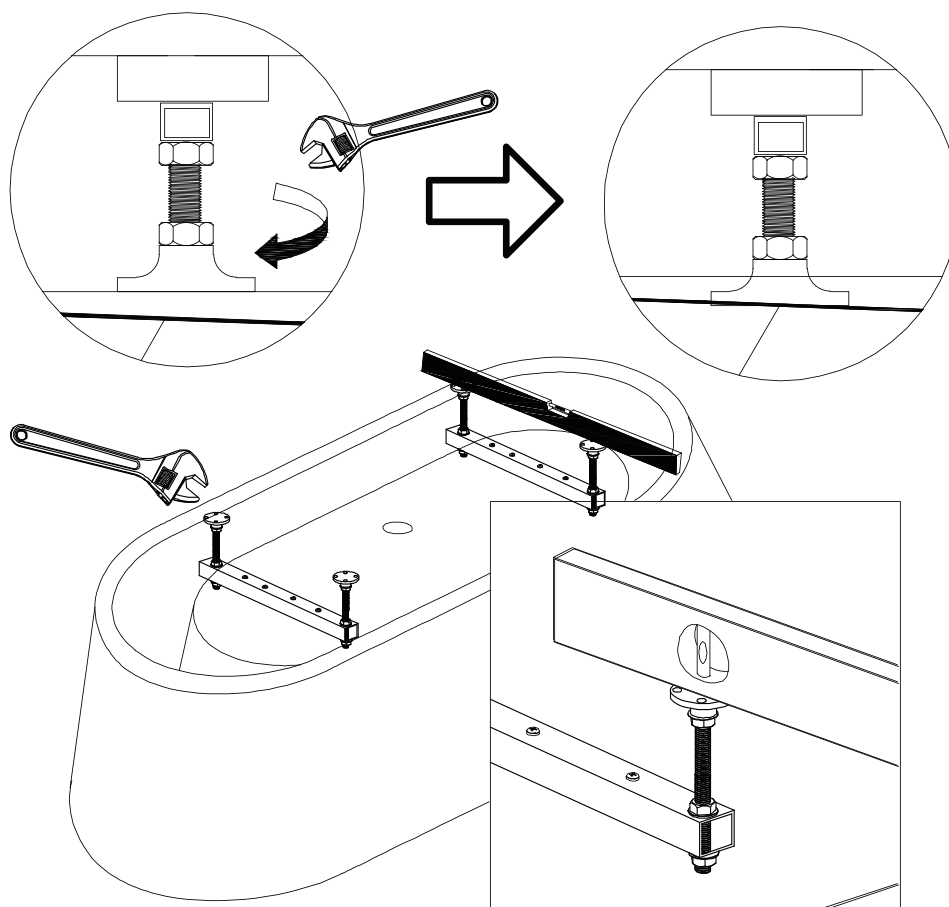

7. Ensure to mark all positions of leveling legs on the floor using a pencil. Move the bathtub into the desired location near the drainpipe.

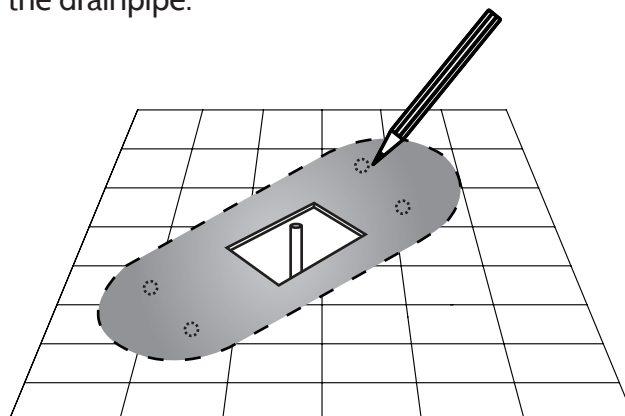

Below is the installation for drain A1866;  
For drain N-DWF-CH/GLD, please skip to page 11



8. Before proceeding with installation, push the pop up into a close position and fill the bathtub above the overflow [Note: some models may not have an overflow] to test for overflow and drain leakage.

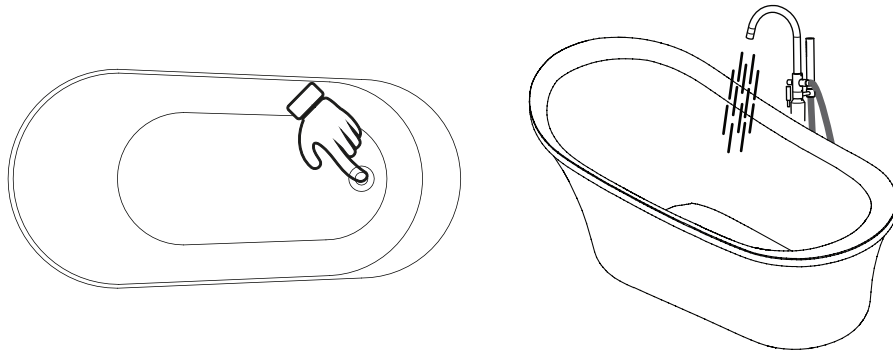

9. Proceed to place the provided flexible drain hose into the floor drain.

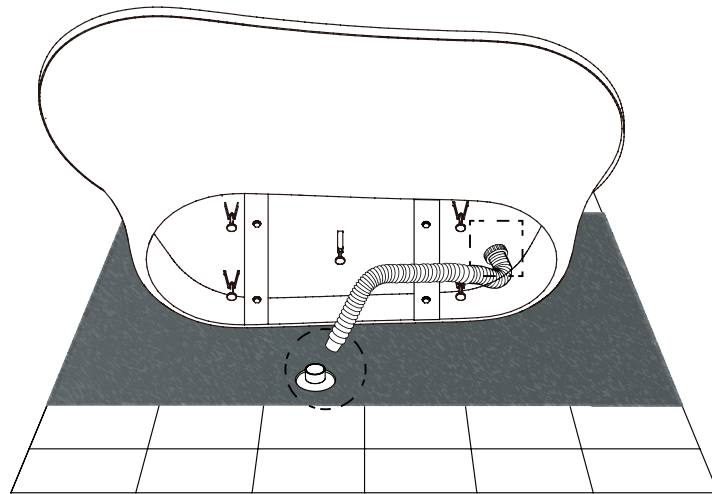

10. Please note, the flexible hose is a basic way that we provide to connect to the end plumbing in a home. The plumbing installation in every home differs, so please consult with a certified plumber to see if the plumbing in your home is compatible with using a basic flexible hose.

11. Seal the connection by using a PVC pipe sealant to join the parts together.

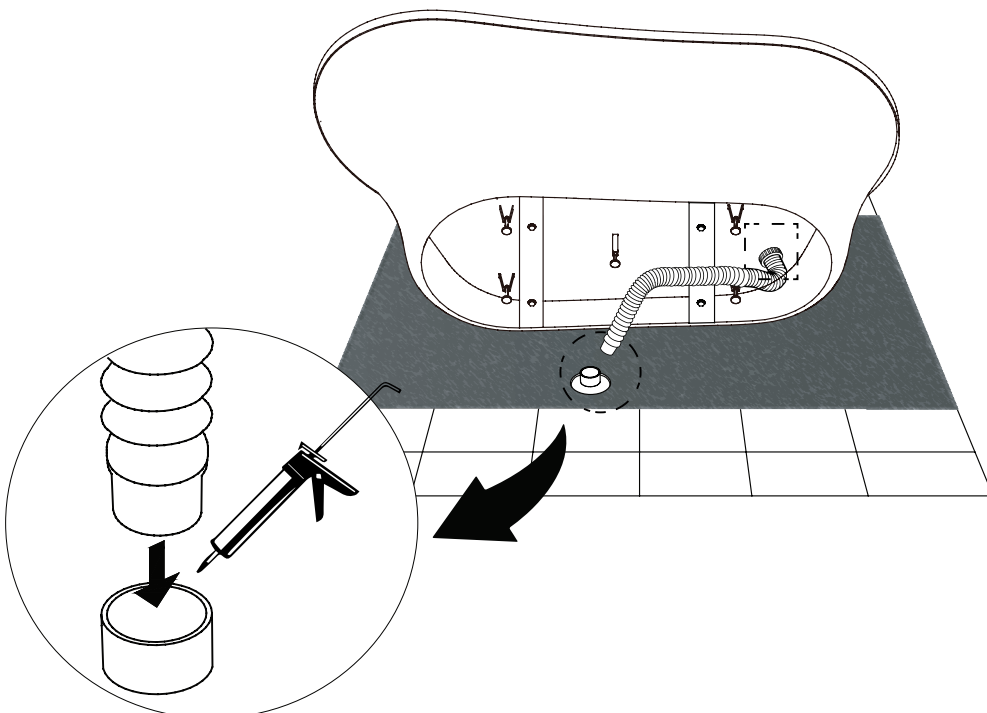

12. Apply silicone along the bottom of the bathtub In order to create an airtight seal. Then apply a bead of tub & tile caulk around the edges of the base.

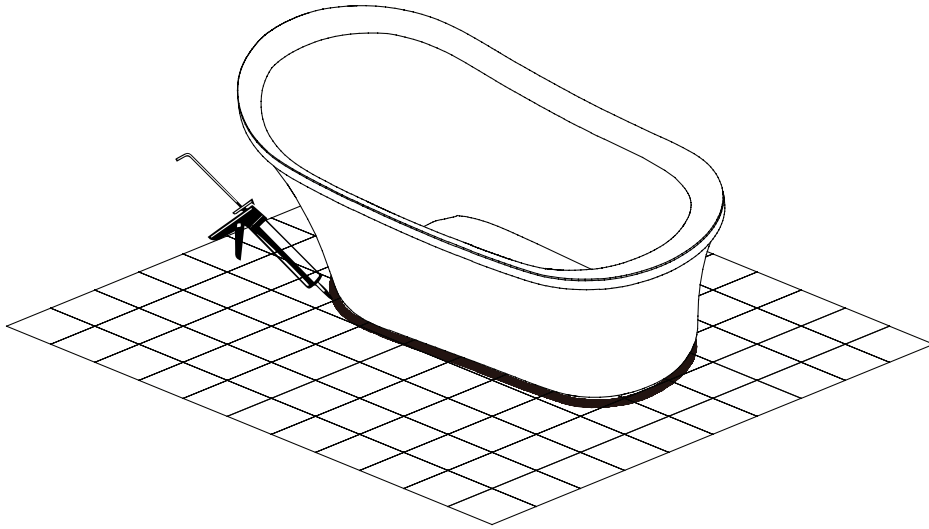

13. With the bathtub now in place, wipe off any excess silicone, tub & tile caulk where the bathtub meets the floor.

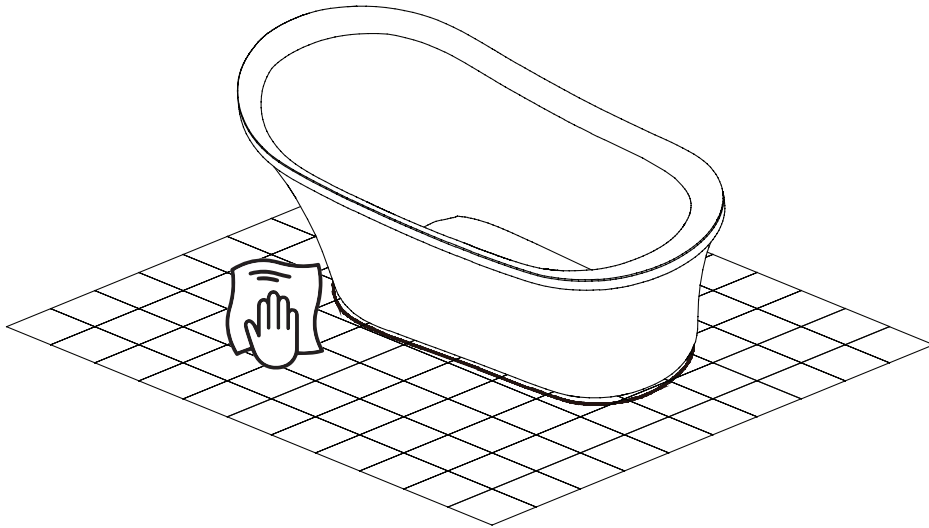

14. Allow for up to 24 hours for the adhesive material to set.

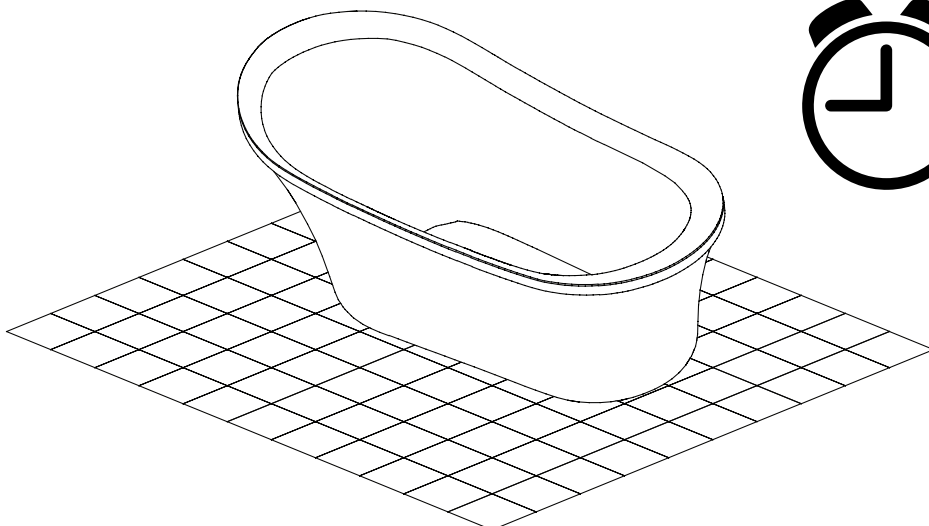

8. Take the strainer, place silicone sealant around it, and then place it into the drain hole ensuring a tight connection with the drain ell & gasket. Use silicone sealant. DO NOT use plumbers putty to seal.

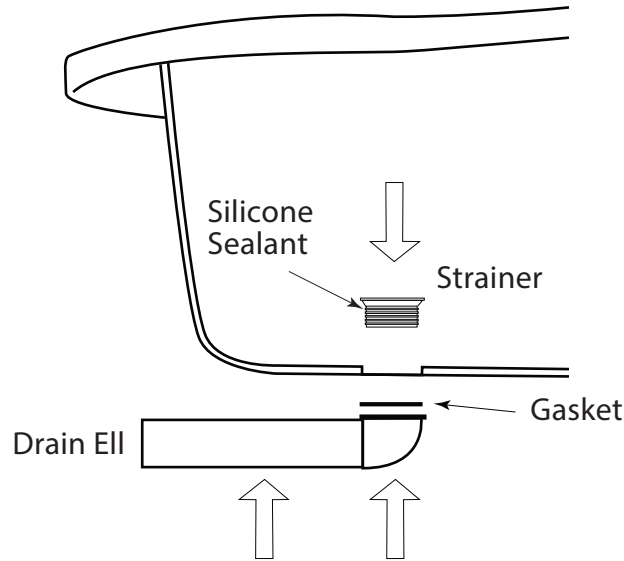

9. Insert the tailpiece into the trap inlet using the O-ring, coupling nut, & flange. The tailpiece may need to be cut for proper fit. 1"-2" of the tail piece should fit inside the trap. Slip the flange over the tailpiece and slide down to the floor.

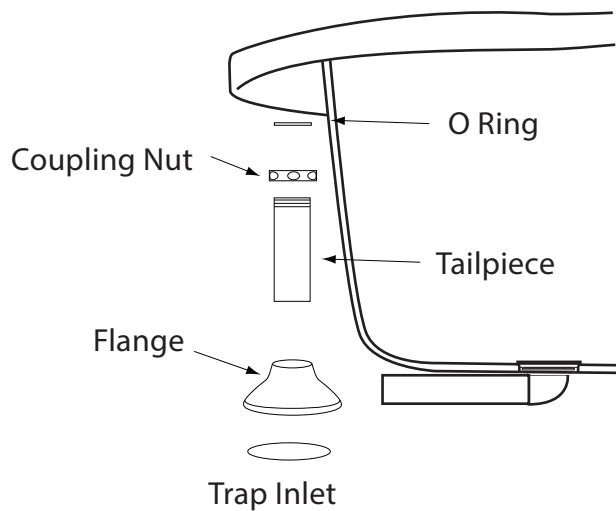

10. Assemble the tee section to the tailpiece, overflow, & drain ell using the coupling nuts and O-rings that are provided.

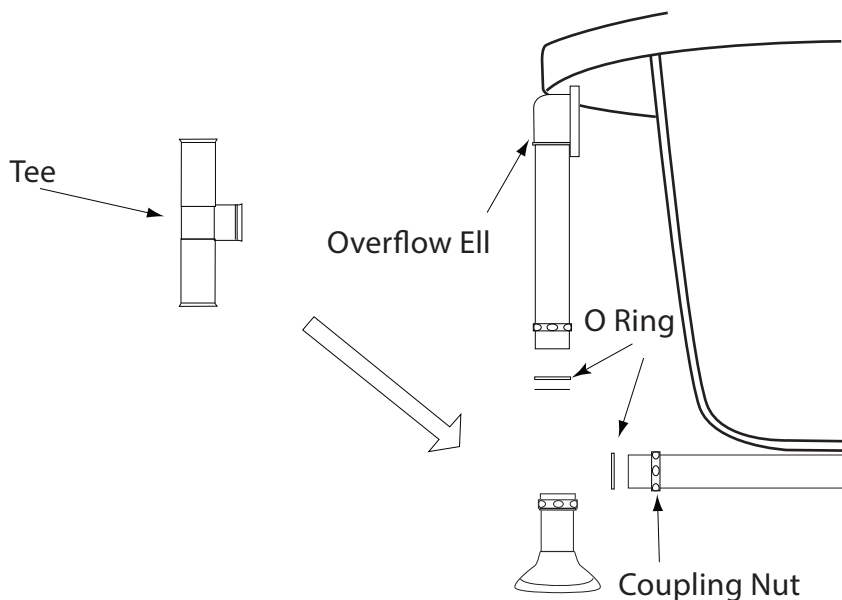

11. Attach the tapered rubber gasket to the overflow ell. Align the overflow ell with the overflow hole & secure the drain to the tub with overflow plate and screw provided.

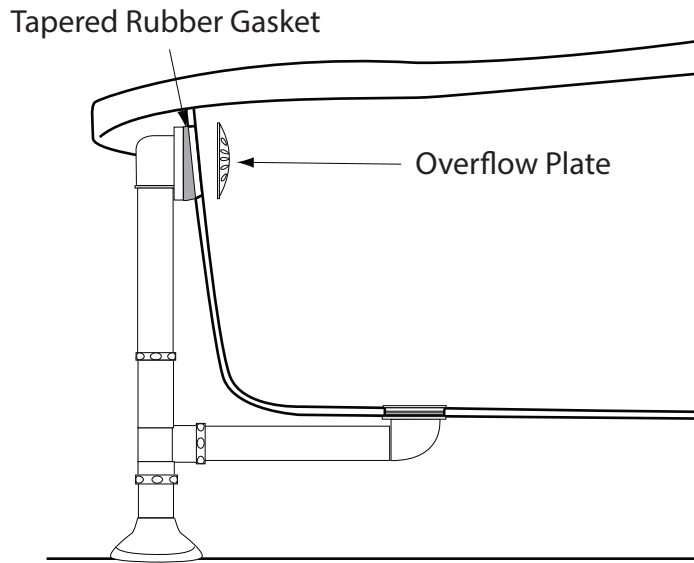

12. Make sure a watertight seal exists on all bath drain connections.

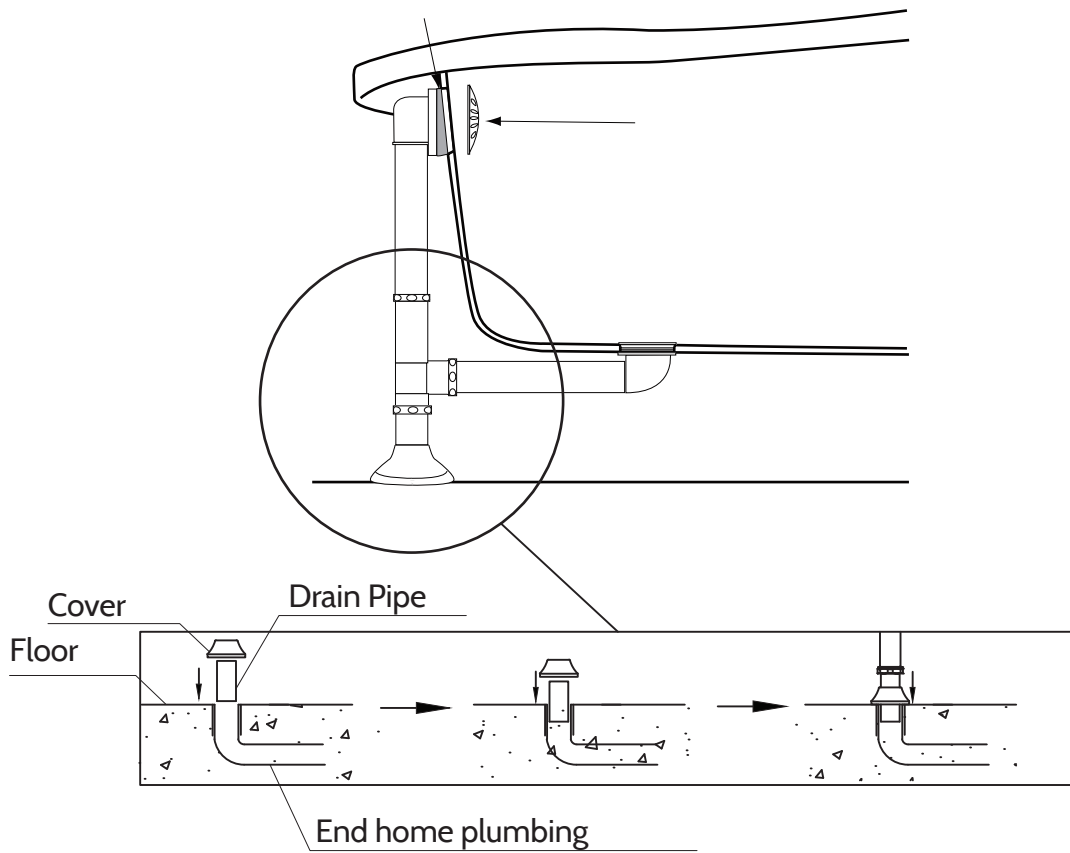

# **SINGLE HANDLE FREESTANDING TUB&SHOWER FAUCET**

**H-120-TFMSHCH**

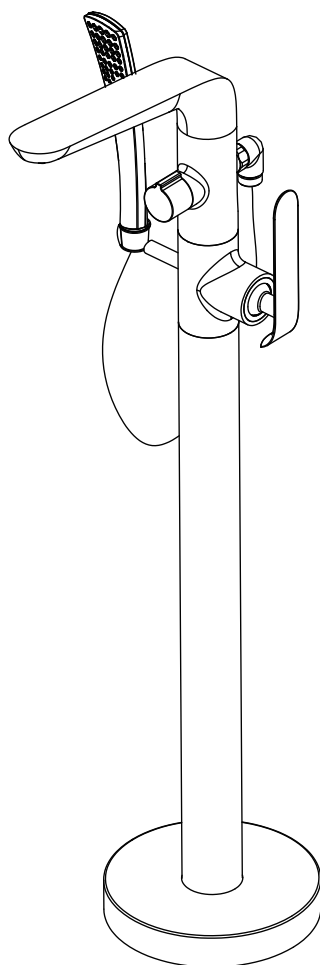

## RECOMMENDED TOOLS

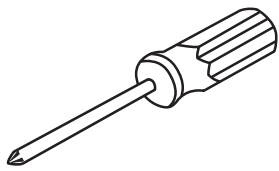

Screwdriver

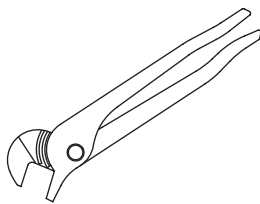

Channel Locks

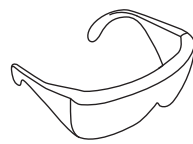

Goggles

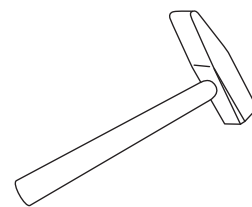

Hammer

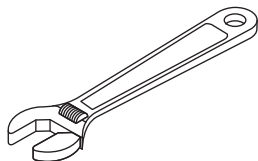

Adjustable Wrench



Teflon tape

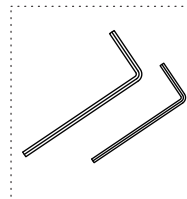

Allen key



**WARNING:**  
Please keep the  
tool for future use!



### ATTENTION:

for easy installation, you will need:

1. To read all the installation instruction completely before beginning.
2. To read all the warning, attention and maintenance information.

### THE TOOLS MIGHT BE APPLIED TO THE FOLLOWING PLACES:

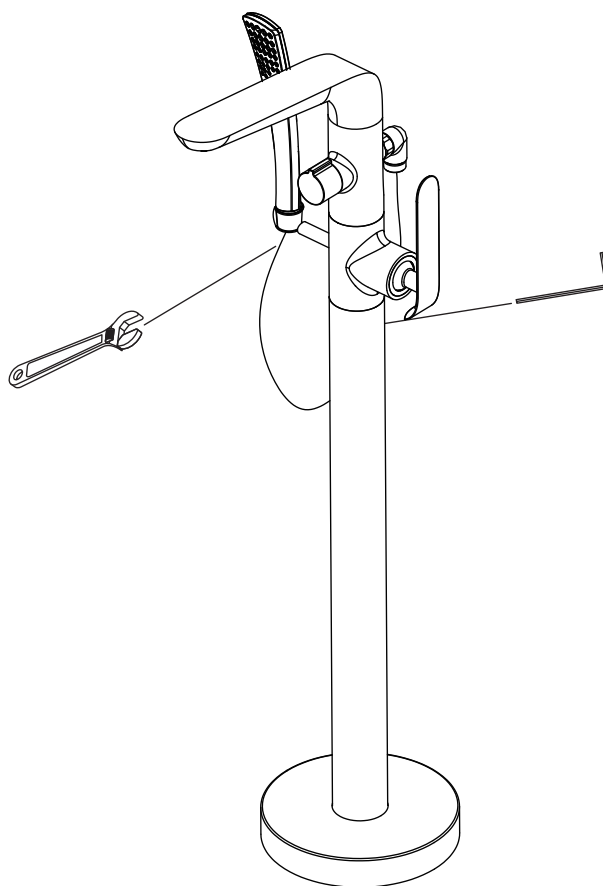

# FAUCET INSTALLATION

1. Drill one hole of 130mmx130mm max and drill 3 holes with 80mm diameter as shown.

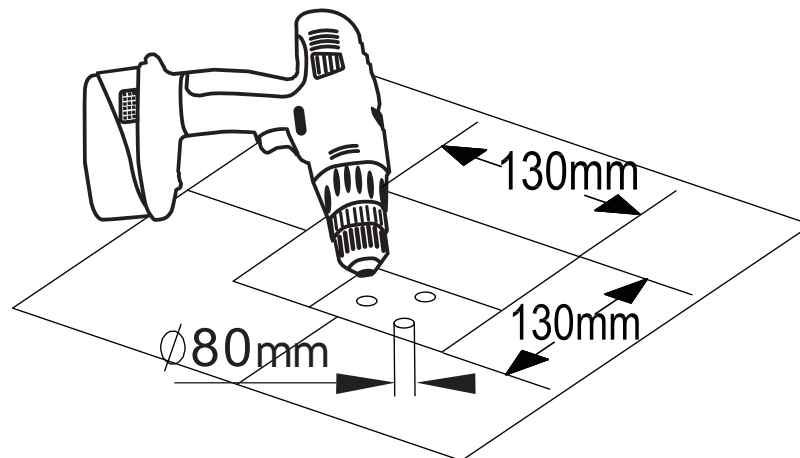

2. Align the base ① with the holes exactly as shown.

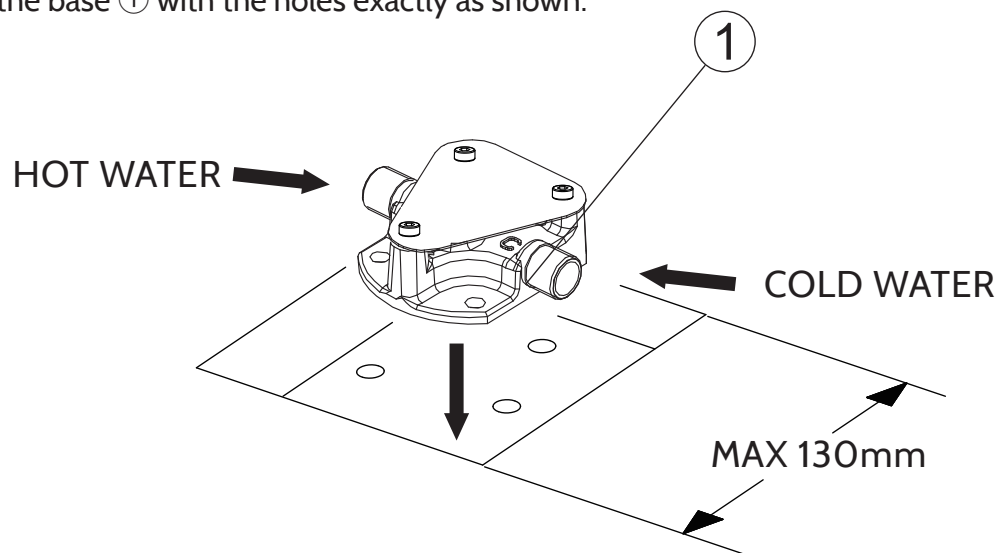

3. Insert the expansion anchors ① into the holes on the base ② with a hammer, tighten with adjustable wrench.

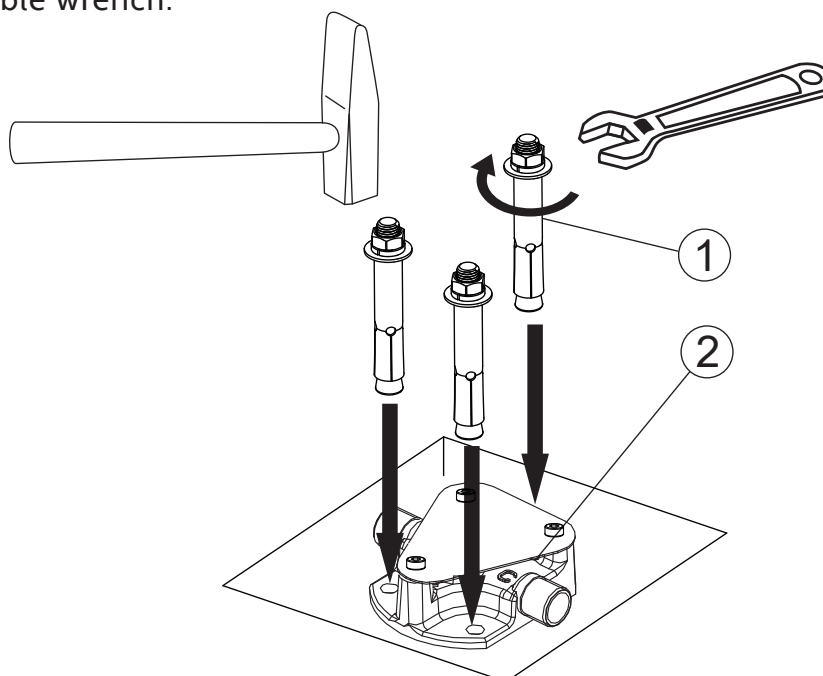

4. Connect hot and cold supply lines and test by opening water lines.

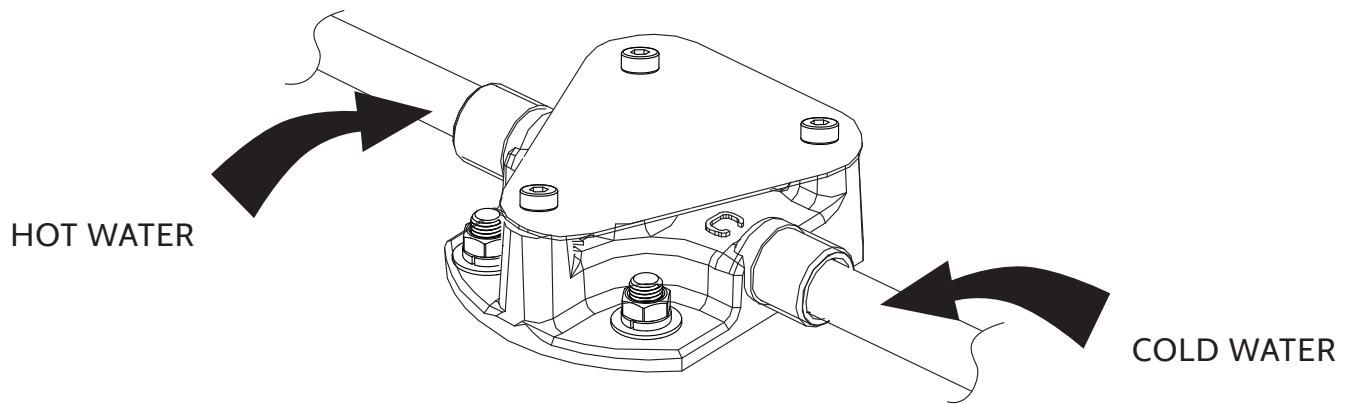

5. If there are no leaks, remove the 3 screws (1) with the Allen key (2), then remove plate (3) and nuts (4) as shown.

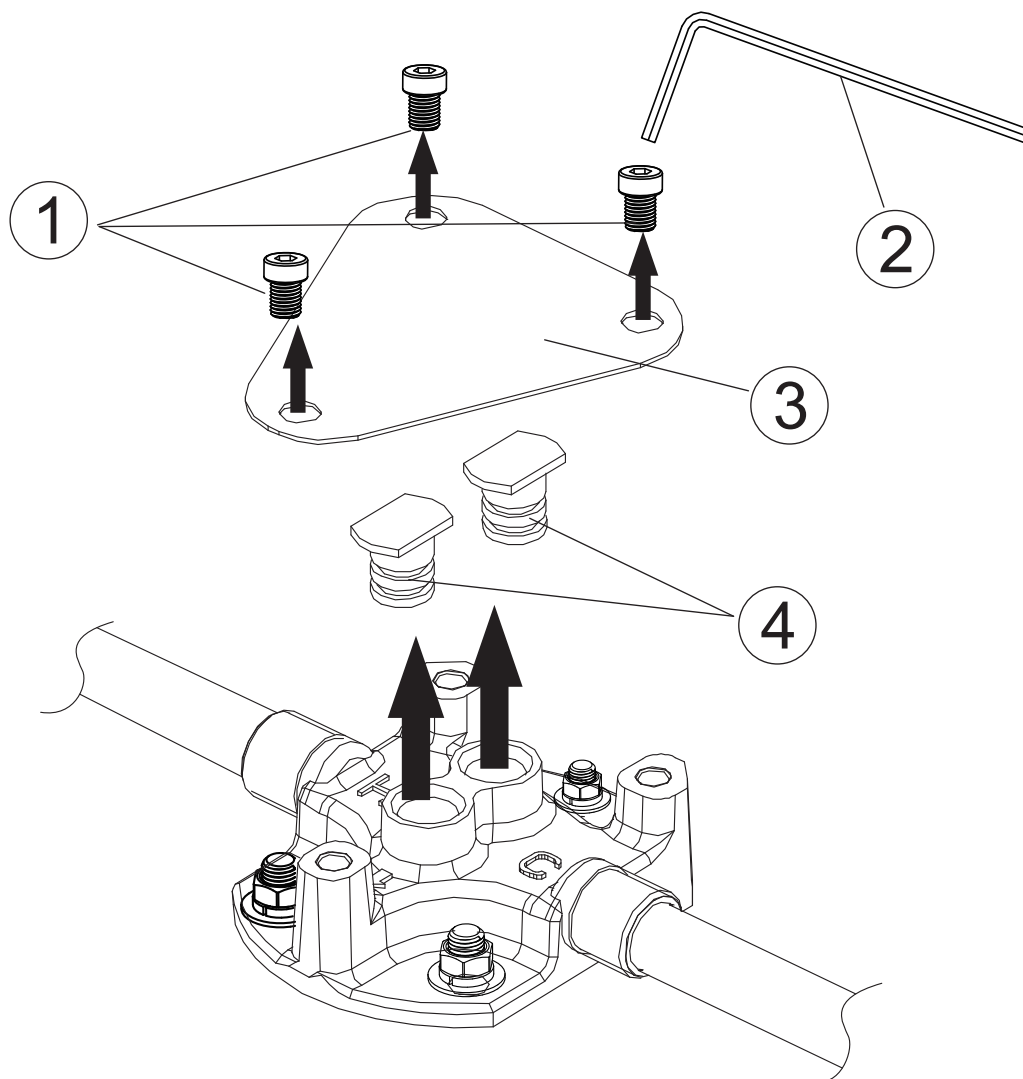



6. Connect hot water flexible hose(1) and cold water flexible hose(1) to the base (2) correctly as shown.

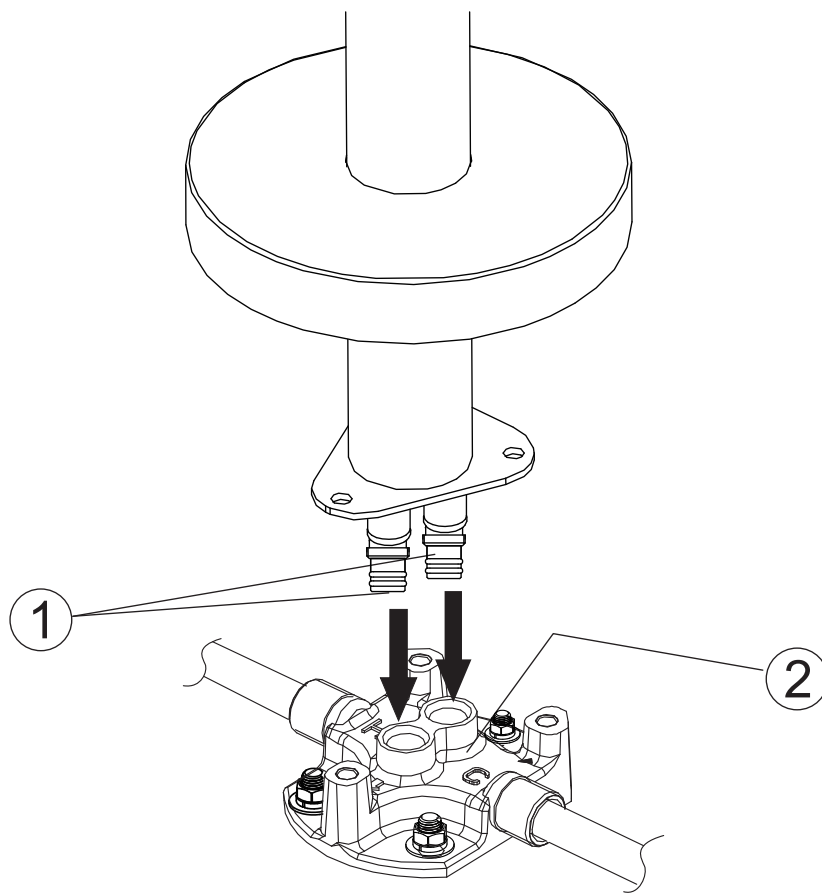

7. Insert 3 screws (1) into holes on the plate (2), tighten with allen key (3).

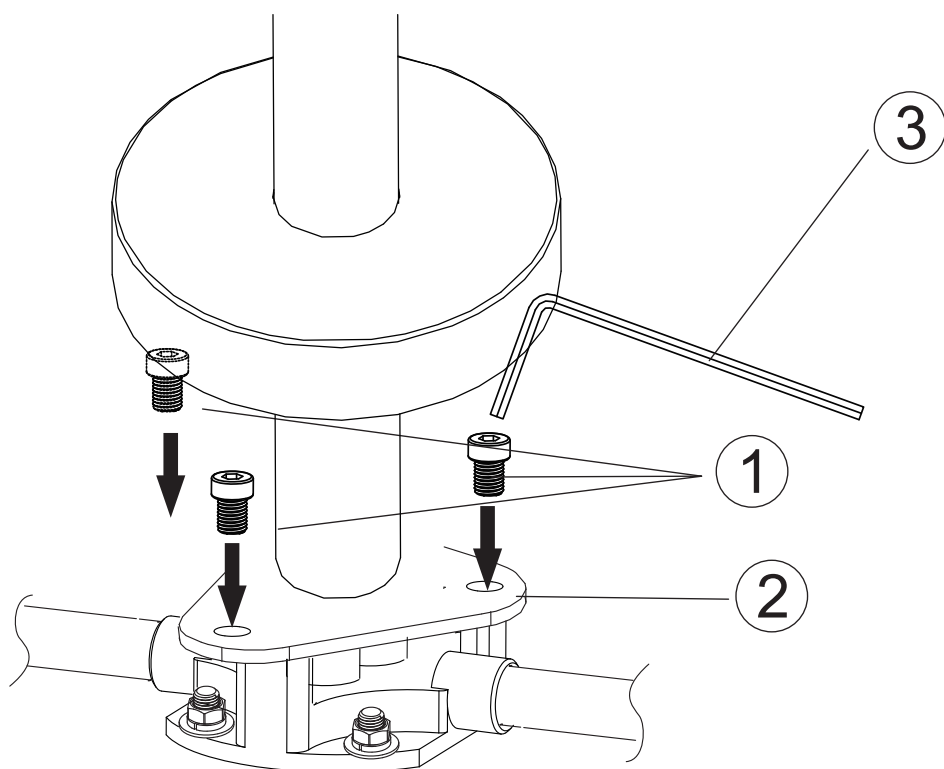

## CHECKING AND TESTING

1. Remove the aerator ② with aerator wrench, take out the o-ring ① too. Turn the faucet handle all the way on, turn on hot and cold water supply and flush water lines for one minute. Reinstall aerator with aerator wrench.

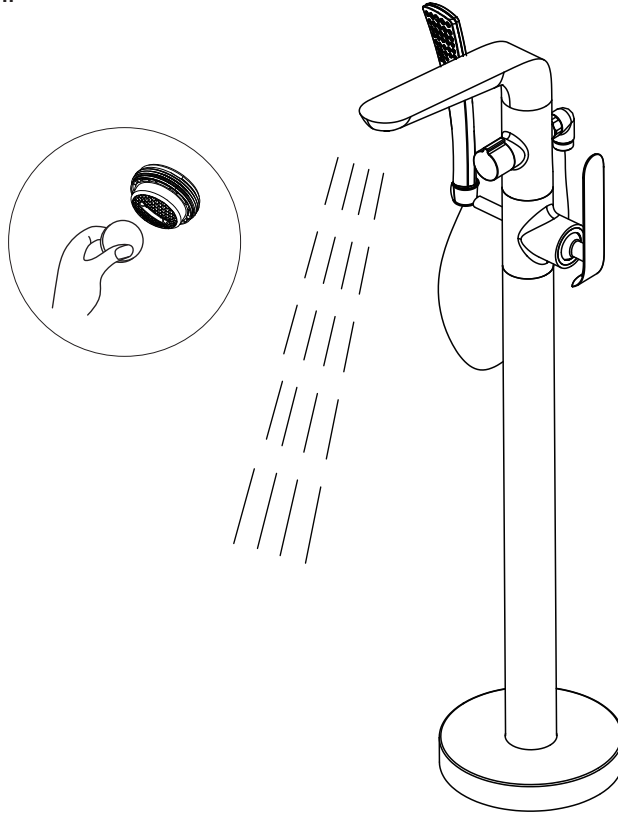

2. Check all connections at arrows for leaks, re-tighten it if necessary.

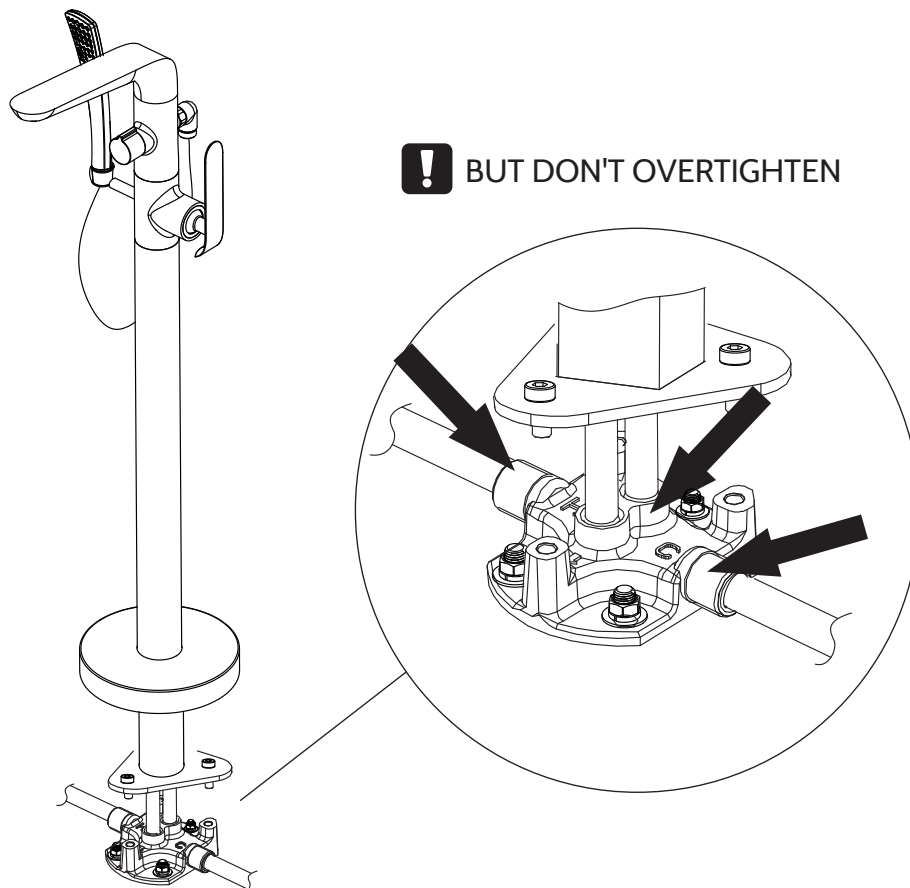

# MAINTENANCE

- A. If there is splash or low flow rate, please remove the aerator with the wrench and clean the debris.

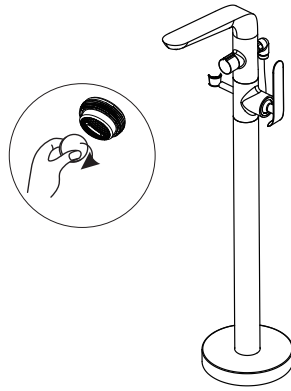

- B. If faucet leaks from the handle or drips from spout, please replace cartridge following the following steps:

1. Disassemble the screw ② with allenkey ①, take out the handle ③, then remove the trim cap ④.

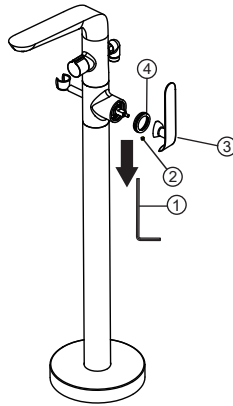

2. Unscrew the cartridge nut ① with adjustable wrench, then take out the old cartridge ②.

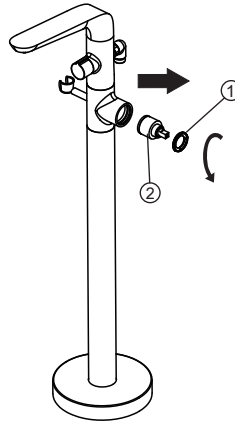

3. Place a new cartridge in the cartridge seat, then screw the cartridge lock nut and assemble the handle by securing the screws. Repeat the above steps for the other cartridge if necessary.

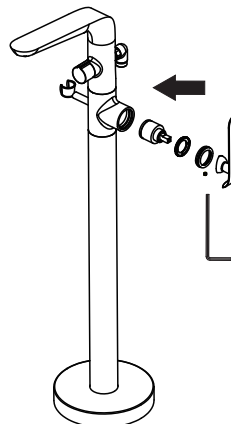

# CLEANING AND CARE

Daily cleaning and care are required in order to keep the product shining and properly working.

1. Clean it with water and dry it with soft cloth.
2. Clean the product with gentle liquid or glass cleaner.
3. Don't use acid cleaner.
4. Don't clean with abrasive material, abrasive paper or knife.

# PARTS LIST

