

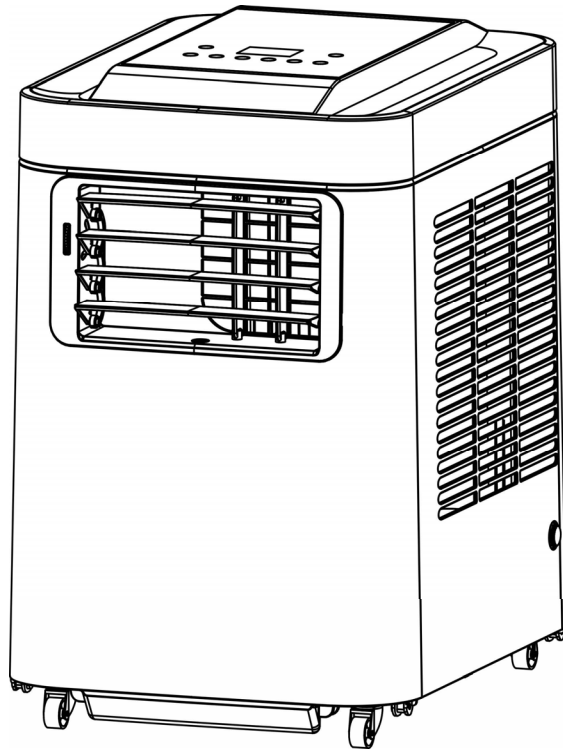

PORTABLE AIR CONDITIONER

EP23475

USER MANUAL



VERY IMPORTANT

Do not install and use your portable air conditioner unit before carefully reading this instruction guide. Please retain this manual brochure for product warranty and future reference

CAUTION

1. " PLEASE MAKE SURE THE PRODUCT VENTILATES ALL THE TIME "! Please make sure the inlet and outlet ventilation is not blocked at all times.
2. Operate this unit on a horizontal surface to avoid water leakage.
3. Do not operate this unit in an explosive or corrosive atmosphere.
4. Operate this unit in an ambient of 95°F degree centigrade or less.
5. Clean air filter periodically to enjoy the most efficient cooling.
6. When the unit is shut off, please wait at least 3.5 minutes before restarting this is to prevent the compressor from being damaged.
7. This unit needs at least 7 Amps of electricity to have its compressor operational. To avoid the household electricity block out, please do not use any extension cord for this unit.
8. The product is only applicable to interior cooling , dehumidifying and fan.
9. When turning on the unit, the fan will operate but the compressor will start up after the cooling alarm flashes for three minutes.

10. To avoid the hazards, contact the manufacturer, the service agent, or similarly qualified persons to replace the damaged power cable.
11. In order to dispose the appliance safely, please remove the batteries from the unit before scrapping it.
12. This appliance can be used by children aged from 8 years and above and persons with reduced physical, sensory or mental capabilities or lack of experience and knowledge if they have been given supervision or instruction concerning use of the appliance in a safe way and understand the hazards involved. Children shall not play with the appliance. Cleaning and user maintenance shall not be made by children without supervision.
13. Please drain water before moving the product.

ATTENTION

For effective cooling functions, please ensure that the following steps are undertaken:

- 1) To achieve the best working efficiency, extend the exhaust hose with the length less than 400 mm.
- 2) A distance of 500mm minimum must be kept between the filter side of the unit and wall or any other obstacles".
- 3) When this appliance starts to defrost, the word "DF" will be displayed on the LED

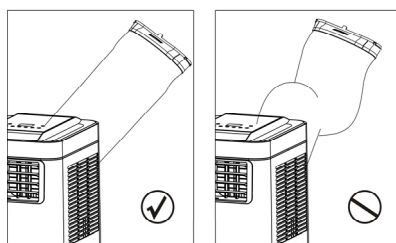
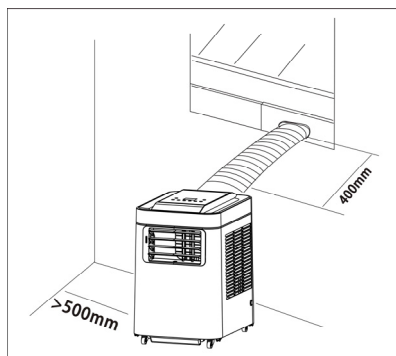

CONGRATULATIONS ON YOUR SELECTION OF A QUALITY PORTABLE AIR CONDITIONER

This Air Conditioner has been designed and manufactured to the highest standards of modern engineering.

Our product not only provides you a remote control to help user operate all the functions easily and conveniently but also has below benefits:

- Moves easily from room to room on easy glide castors
- No installation required-just plug into any household power outlet
- Powerful refrigerated air system cools down the ambience instantly whenever you want.
- Dehumidified and filtered air cycle improve breathing environments effectively.
- Besides the remote control, your one touch electronic pad also provides easy-identifying manual operation.
- 24 hour programmable timer that can be used with either the air conditioning or dehumidification setting
- Unique sleep control function
- 120 Volt 60Hz operation

UNPACKING INSTRUCTIONS

1. Please put the product in a right direction before unpacking.
2. Cut off the straps.
3. Grasp the carton box and hoist it so that the product can slide from the bottom of the box.
4. Hold the air outlet at both sides of the product and raise it carefully from the foam base.
5. Hold and incline the product slightly to take The Inner joint of exhaust hose and exhaust pipe out of the base, as shown in the figure.
6. Please install the exhaust hose on the product before use.

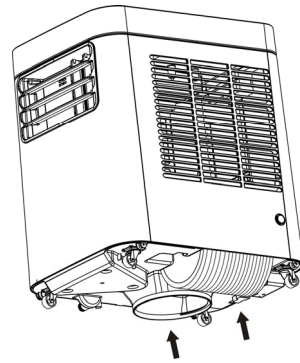

CONTENTS

- 1/ Air conditioner unit
- 2/ Exhaust hose, (with exhaust hose outer joint inside)
- 3/ Exhaust hose inner joint
- 4/ Upper Foam
- 5/ Bottom Foam Base
- 6/ Remote controller
- 7/ Batteries
- 8/ User Manual

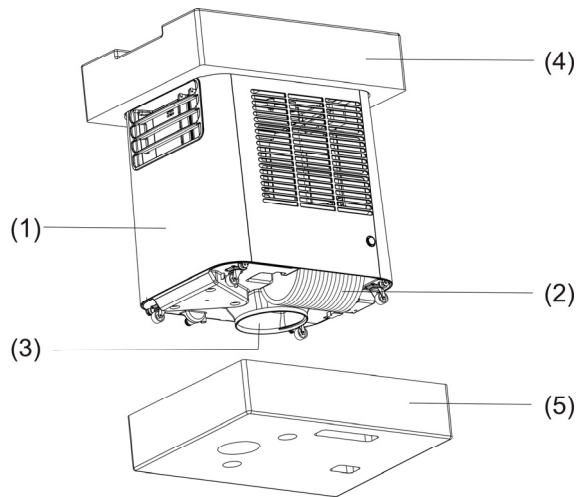

NAME OF THE PARTS

1. Control panel
2. Remote control receiver
3. Cool air outlet
4. Filter of evaporator
5. Cool air outlet
6. Upside drain hole

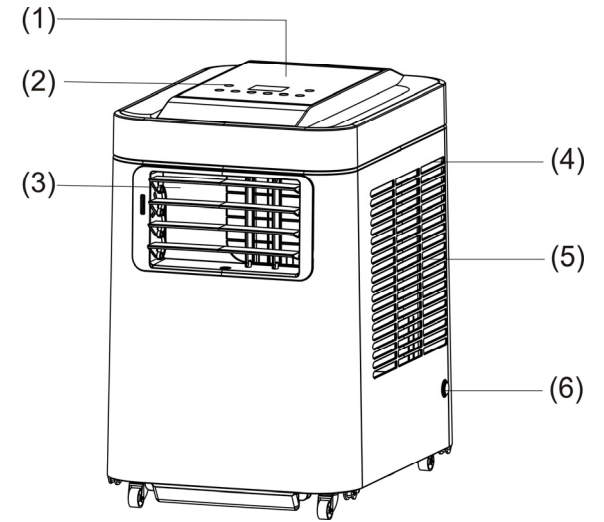

7. Hot air outlet
8. Filter of condenser
9. Hot air inlet
10. Lower drain hole

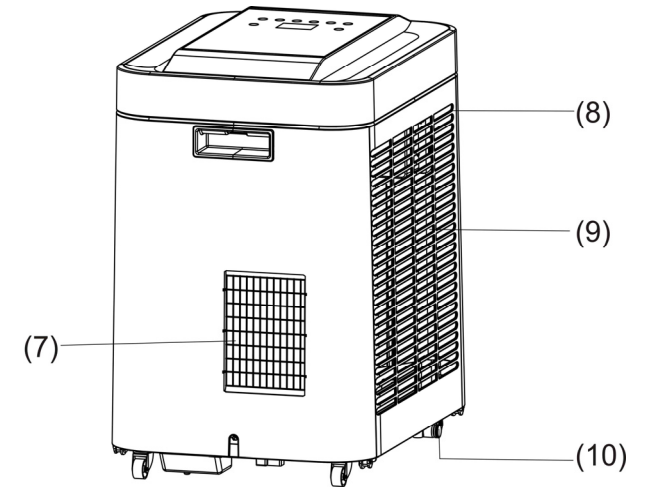

EXHAUST HOSE INSTALLATION

1. Please take out the joints from exhaust hose according to the figure "①" and connect joint a with joint b.

2. Please connect the air outlet joint with the exhaust hose in the direction according to the figure "②".

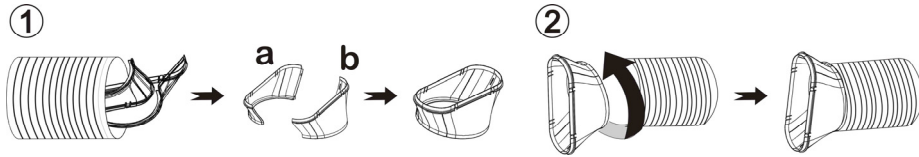

1. Please rotate the exhaust hose in the direction as shown in the figure "③" so that the exhaust hose can be connected with the inner joint.

2. Please connect the exhaust pipe inner joint with the product as shown in the figure "④"

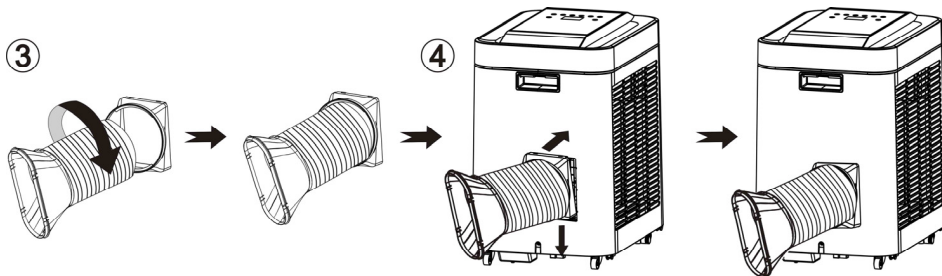

CONTROL PANEL AND FUNCTION INTRODUCTION

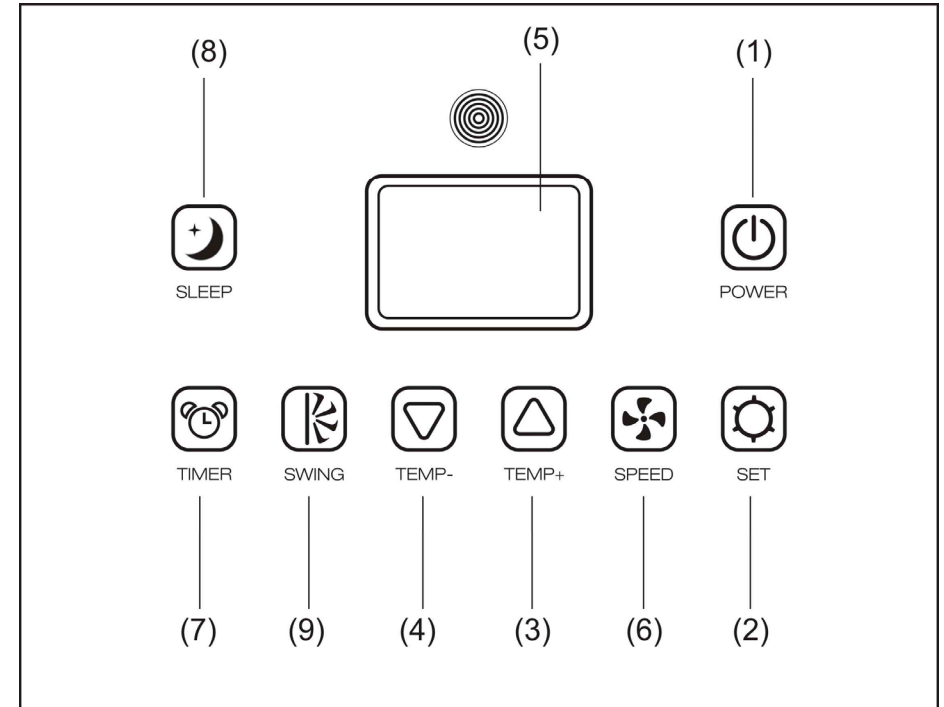

1. POWER KEY

Press to turn unit "ON" or "OFF".

2. FUNCTION

Press this key to select cooling, dehumidifying or fan.

3. TEMPERATURE REGULATION KEY (UP)

Cooling mode (+): add 33.8°F by pressing the button once until 86°F at highest

4. TEMPERATURE REGULATION KEY (DOWN)

Cooling mode (-): reduce 33.8°F by pressing the button once until 62.6°F at lowest

5. L.C.D. DISPLAY

The display indicates the current setting temperature or the timer setting. When setting temperature or timer, the new setting is shown then the display returns the

current set temperature.

※ The display is also used to show error codes when a fault occur, see "ERROR CODES".

6. SPEED

Press to select either LOW, MEDIUM, HIGH or AUTO fan speed.

If "AUTO" is selected (During cooling function),"HIGH" or "MEDIUM" or "LOW" will be selected automatically according to the difference between setting temperature and ambient temperature.

Note: In dehumidifying function, this key is invalid because the unit is **defined** to low speed in dehumidifying mode.

7. PROGRAMMABLE TIMER

Programmable timer ON/OFF key.

TIMER-ON: The timer-on is used to turn on the unit automatically after the set time is over.

1. Press the "TIMER" key at stand-by status to set the time you desired.
2. Once the set hour has come to an end, the unit will turn on automatically.
3. Press the "POWER" key before time out, the setting time will be canceled and the unit will turn on.
4. You can set the function and fan speed while setting the timer.

TIMER-OFF: The timer-off is used to turn off the unit automatically after the setting time is over.

1. Press the "TIMER" key at operating status to set the time you desired.
2. Once the set hour has come to an end, the unit will turn off automatically.
3. Press the "POWER" key before the time out, the setting time will be canceled and the unit will turn off.

8. SLEEP CONTROL FUNCTION

1. While in cooling mode, press the SLEEP key to set the temperature. It increases 33.8°F after an hour and at most increases 35.6°F after 2 hours.
2. Press the SLEEP key again can cancel the setting.

9. SWING

Press this key and the outlet will cycle oscillating, and it will stop when this key pressed again .The blade will back to middle after turn off the appliance.

10. ALARM

When the water tank is full,"E4" will be displayed on the display panel. To resume operation, please remove the rubber cap of the drain hose to drain out the water firstly. The E4 warning will disappear after draining, and then you can restart the unit by pressing the POWER key.

REMOTE CONTROL FUNCTION

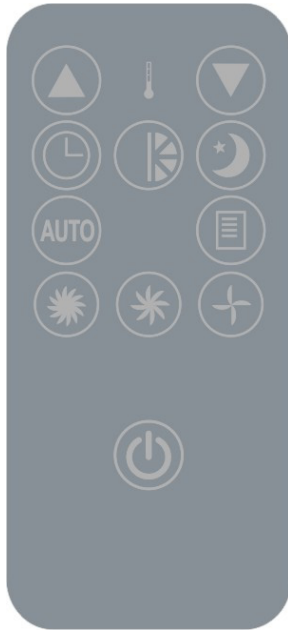

1. POWER 
2. FUNC 
3. TIMER 
4. AUTO 
5. HI 
6. MID 
7. LOW 
8. SLEEP 
9. TEMP. 
10. SWING 

- On/Off switch
- Function "MODE" selector
- Hourly programming
- Automatic fan speed
- High fan speed
- Mid fan speed
- Low fan speed
- Night operation selector
- Temperature selector
- Swing

NOTICE

The product can evaporate condensate water and drain the water through exhaust hose automatically.

1. When the product is cooling, there is no need to install the drain pipe. Please make sure the drain hole is installed with rubber cap
 2. When the product is dehumidifying, pull the rubber cap "①" from the drain hole and install a suitable drain pipe
- Please remove the rubber cap to enhance the dehumidification ability.
- ※ When the water tank is full, "E4" will be displayed on the display panel. Please remove the rubber cap "②" of the drain hole to drain out the water first. After the "E4" disappeared, please restart the unit and then the unit can operate normally.

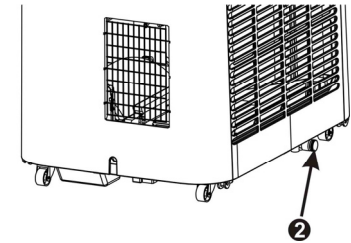
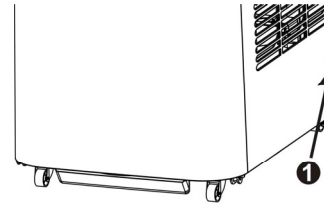

MAINTENANCE

Please cut off the power before cleaning.

FILTER

Grab the upper panel firmly by the place pointed by two arrows in picture ①, and lift upward the upper panel as shown in picture ②.

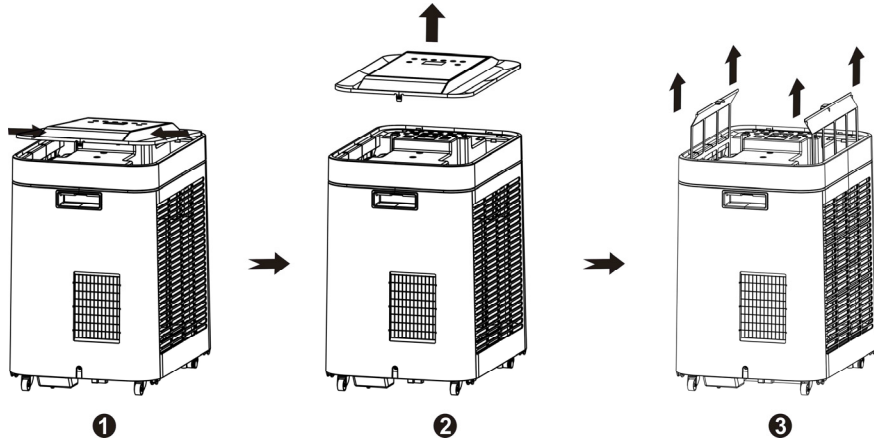

CONDENSER/EVAPORATOR

Use a brush attachment with a vacuum cleaner.

Shell

Clean the shell with wet cloth and wax it with soft cloth.

Please pull the filter up slightly according to the direction as shown in the figure to remove the filter screen for cleaning

WINDOW KIT INSTALL

- ◆ Install the Exhaust Hose and the Adjustable Window Slider Kit as depicted in Fig.1 & Fig.1a.

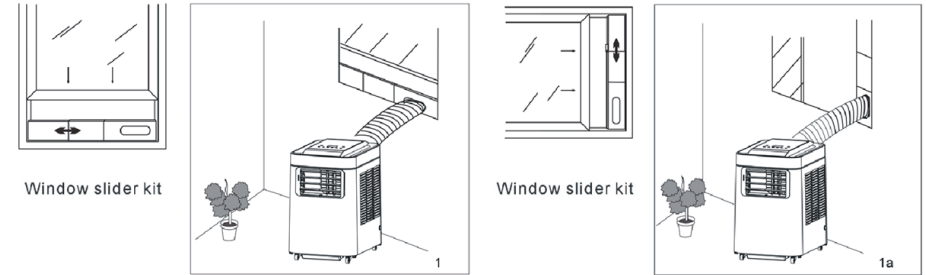

POWER SUPPLY

- (1) Confirm the correct power.
- (2) Insert the plug into the outlet firmly-In order to prevent any dangerous leakage.
- (3) Don't pull power wire by force because it will cause damage to power wire.



PLACE FOR USE

- (1) Because the machine distributes hot air, please don't place or operate in a narrow place.
- (2) In case of dangerous leak, don't work the machine in a humid place.
- (3) Don't place the machine in a sunlit corner otherwise the unit might shut down due to the overheat and the color of the machine may soon fade out.

HELPFUL HINTS

The unit is fitted with a special thermal cut off device.

Please ensure the unit is not placed against objects which will obstruct air intake e.g. furniture or curtains as this will affect it's performance dramatically.

TROUBLE SHOOTING

Problem	Cause	Trouble shooting
E1	Electrical short on both temperature sensor and PCB	Contact maintenance station to repair
E2	Electrical short on both temperature sensor and PCB	Contact maintenance station to repair
E4	Indicates water tank full	User needs to pull out the rubber stopper which is located at the bottom of the unit, to drain the water away.

SPECIFICATION

Model No.	EP23475
Power Source	120V~60Hz
Cooling Capacity	10000BTU/H
Cooling Power Input	1080W
EER	8.8
Amps(Cooling)	9.5A
Moisture Removed	105.7 Pints/Day
Refrigerant	R410A

MADE IN CHINA

(CE) N 842/2006:

R410A is a kind of fluorinated greenhouse gases covered by the Kyoto Protocol.

Its total global warming potential (GWP) is 2088.



This marking indicates that this product should not be disposed with other household wastes throughout the EU. To prevent possible hazards to the environment or human health from uncontrolled waste disposal, please recycle it to prove the sustainable reuse of material resources. Please ask return and collection systems or contact the retailer where the product was purchased to return your used device, they can recycle products safely.