

# FUTURA WATER SOFTENER

---

SALT FREE ANTI-SCALE WATER CONDITIONER

## INSTALLATION INSTRUCTION & OWNER'S MANUAL Ver 1.6



**APEC WATER**



[www.freedrinkingwater.com](http://www.freedrinkingwater.com)

All Rights Reserved © APEC Water Systems

Thank you for choosing APEC Futura Salt Free Anti-Scale Water Conditioning System.

Please read and become familiar with instructions and parts needed before proceeding with the installation.

## Parts List for Futura Salt Free Anti-Scale Water Conditioning System

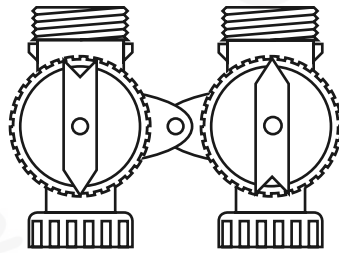

Bypass Valve

1 Each Bypass Valve

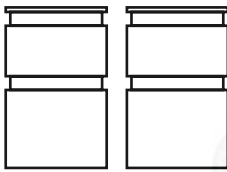

1" Brass Sweat Adapter Kit

1 Set of 1" Brass Sweat Adapter Kit

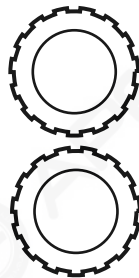

2 - 1" Quick Connects

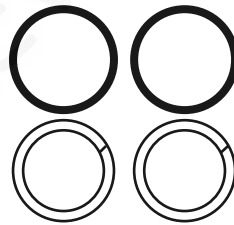

Plastic Split Rings & Rubber O Rings

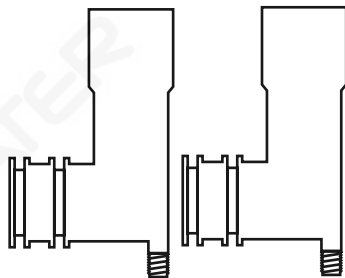

4 - 3/4" To 1" PVC 90° Elbow Solvent Kit

1 Set of 3/4" to 1" PVC Solvent 90 Degree Adapter Kit

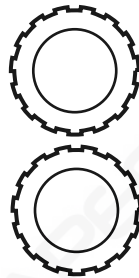

2 - 1" Quick Connects

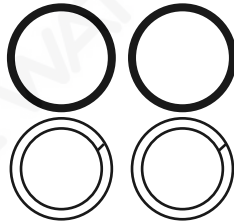

Plastic Split Rings & Rubber O Rings

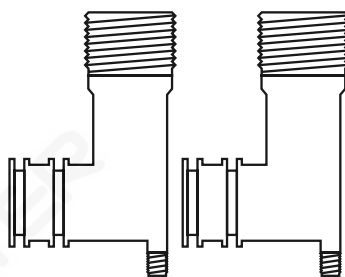

5 - 3/4" To 1" PVC Threaded Male Elbow

1 set of 3/4" to 1" PVC Threaded Male Elbow Assembly

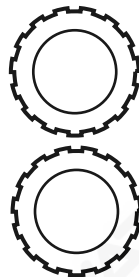

2 - 1" Quick Connects

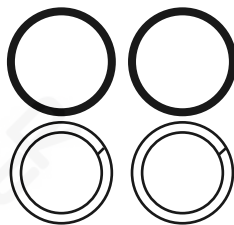

Plastic Split Rings & Rubber O Rings

## Pre Installation Preparation:

The media in the Futura Softener is recommended to be soaked by water for 15 to 20 minutes before use. The salt free ceramic media has already been placed in the Futura media tank by the manufacturer. Place the Futura Softener at the location of installation, as the tank will be heavy to move once filled with water. Once the system input/output connections are connected, please turn on the incoming water supply to fill the Futura Softener and soak the media for 15-20 minutes before using water at the home.

## System Installation:

This is an overview for system installation

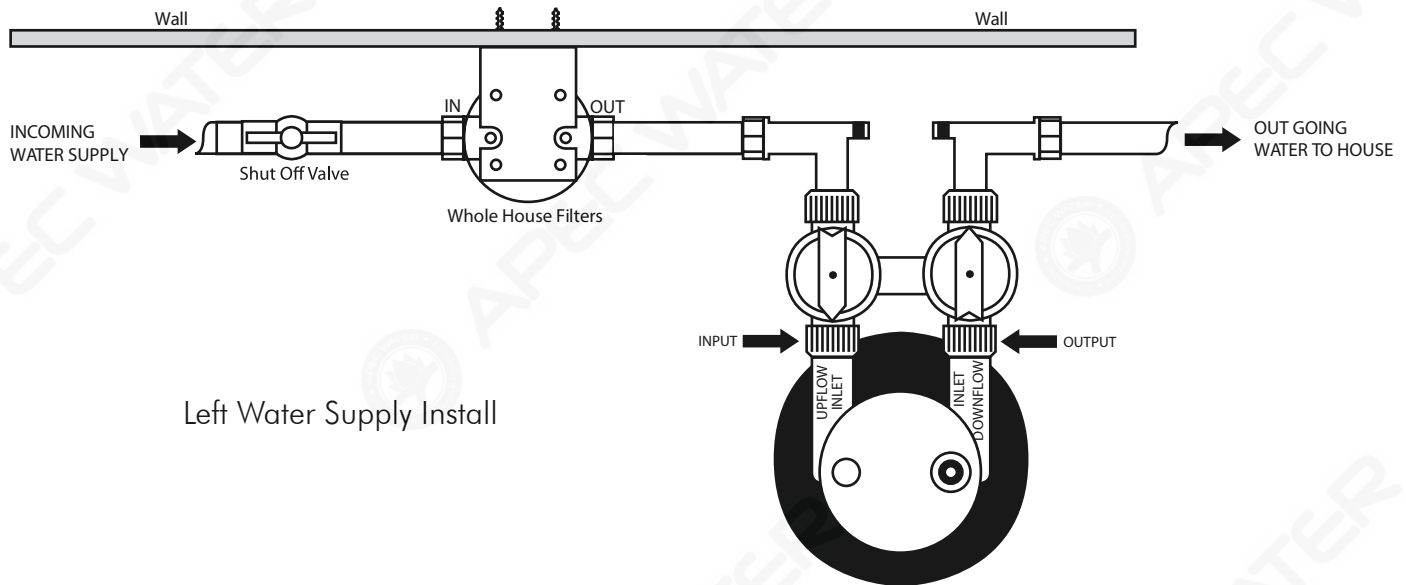

Left Water Supply Install

1. Turn off water supply where it enters the building.
2. Install a shut off valve (if needed) then install the Whole House Carbon Filter in the vertical position. Make sure the flow direction is correct. Plumbing pipes are not designed to support the weight of the filter. Use a mounting bracket to secure the Whole House Carbon Filter to the wall. Be sure to remove the plastic wrap on the filter before installing the filter. (See installation guide for Whole House Carbon Filter for more detail information)

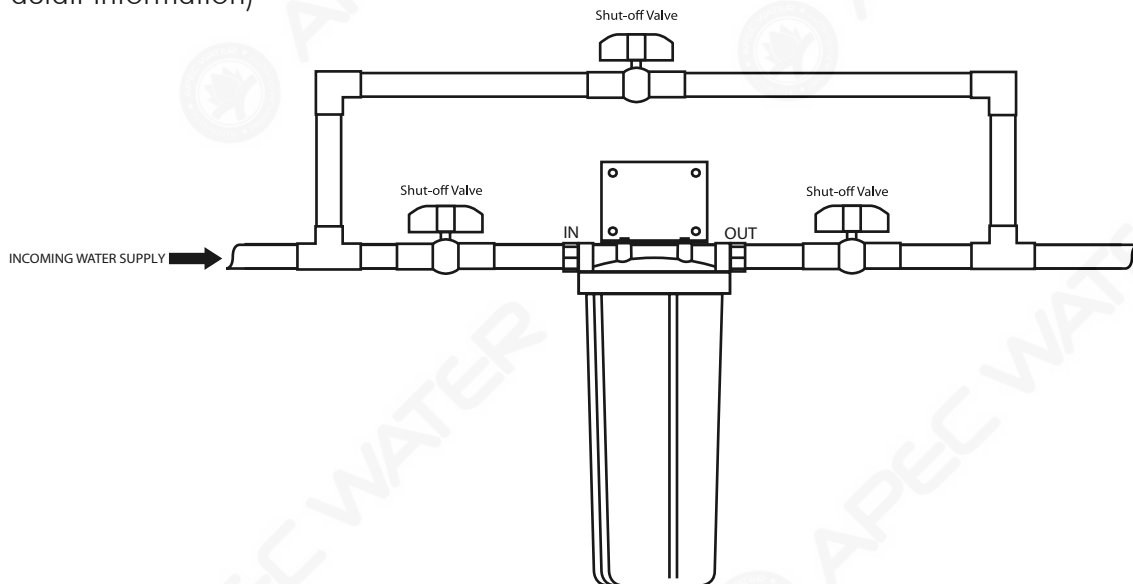

3. The bypass valve comes complete with O-rings, split rings and black quick connector nuts. Install the bypass valve by pressing the valve onto the head of the tank and hand tighten both black quick connect nuts.
4. When running the piping for the Futura Water Softener, connect the incoming water supply to the UP-FLOW INLET side. Connect the water supply line going into the house to the down-flow inlet side.

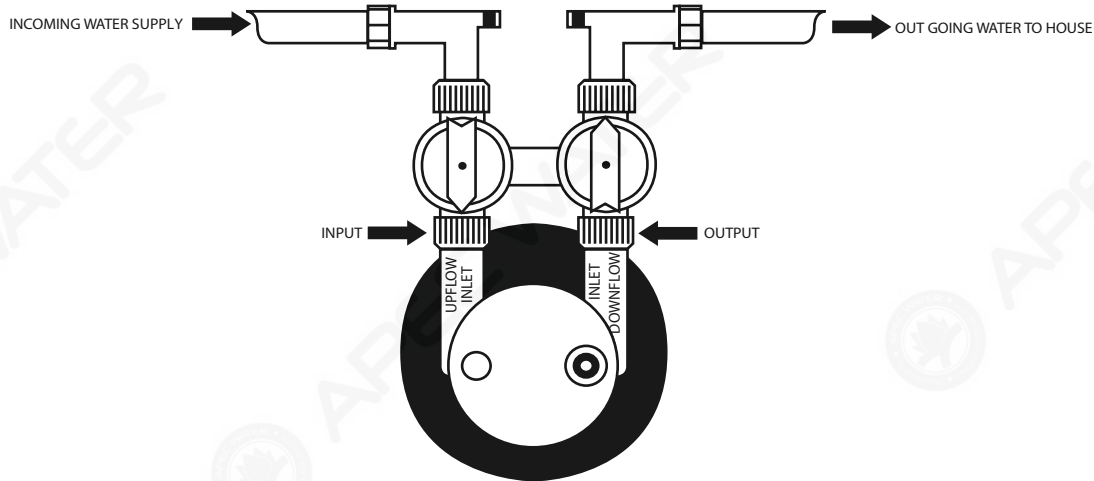

5. Use the appropriate fitting connections to the bypass valve. Brass Sweat Adapter Kit for copper piping and PVC Solvent 90 degree Adapter Kit for PVC Piping. (Follow the instructions supplied with the fittings for assembly)

- a. **Important:** If soldering connections are used, do not install the o-rings, split rings and black quick connector nuts until the soldering are done and given time to cool down. Heat from soldering might damage plastic and rubber components.
- b. **Important:** If PVC solvent connections are used, use solvent cements and primers to connect fittings and piping. Allow solvent cements to set before installing the black quick connector nut, split ring and O-rings.

## Bypass Valve Operation Mode

**Normal Operation Mode:** Water flows through the Bypass Valve and into the Futura supplying treated water into the house.

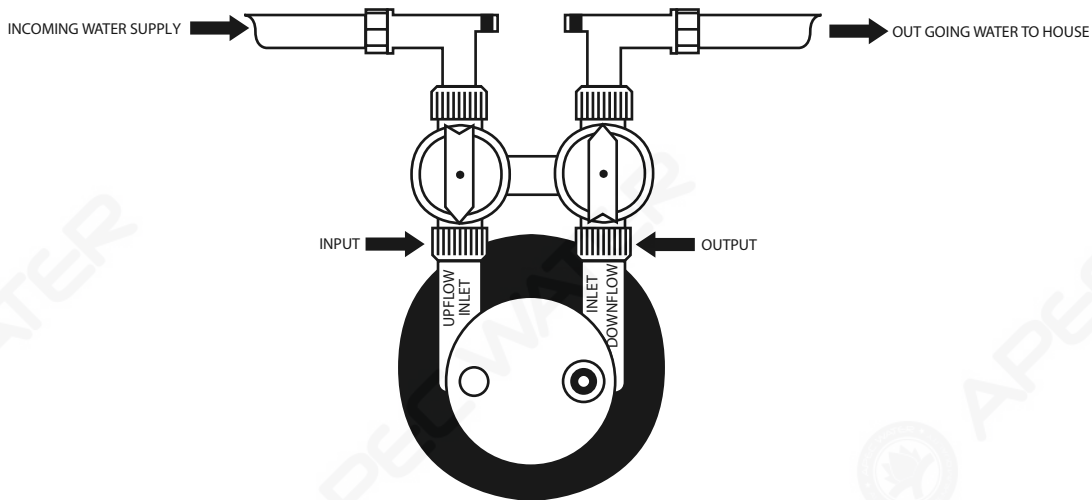

**Bypass Operation Mode:** Water flows through the Bypass Valve without entering the Futura and the water entering the house is untreated.

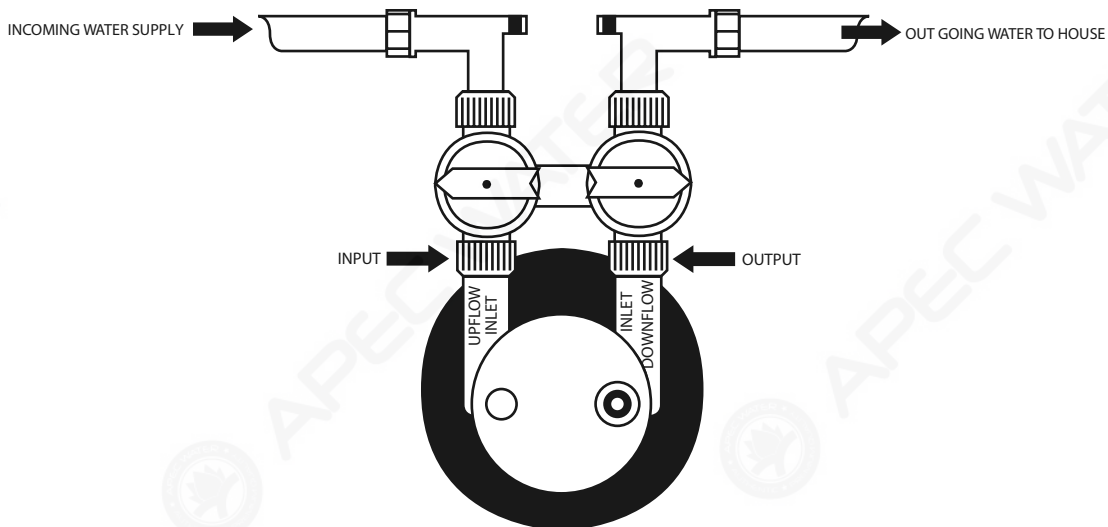

6. Once the Futura Water Softener is hooked up, slowly turn the water supply on. Use high flow rate to flush the system for 15 minutes. Turn on 2 or 3 **COLD WATER** faucets that are located nearest the Futura all the way open to flush the system. Preferably outside garden hose faucets that do not have any aerators attached to it. If using household faucets, use bathtub faucet or remove aerators for sink faucets. It is normal to see small particles of media that is flushed out by the water. We have supplied enough media in the Futura to compensate for this. Make sure the control valve is secured as the head mail swivel loose during the bypass connections. **Check for leaks on all connections.**

**\*\*\* End of Installation Guide \*\*\***

# OWNER'S MANUAL

Please read this section for basic questions and concepts on the FUTURA Salt-Free AntiScale Water Softener/ Conditioner.

## TABLE OF CONTENTS

FUTURA Vs. Traditional Softener .....	Page 6
Prevent Scale Buildup .....	Page 7
Rusted Water Pipes .....	Page 7
Clean the Media .....	Page 7
Microorganisms .....	Page 7
Allowed the Media to Rest .....	Page 7
25 Grains of Hardness or More .....	Page 8
Test the Soften Water .....	Page 8
Composition of the Media .....	Page 8
Maximum Operating Temperature .....	Page 9
ph Range .....	Page 9
Special Precautions .....	Page 9
Replace the Depleted Media .....	Page 9

## Maintenance: Frequently Asked Questions

The Information provided will help keep your Futura Water Softener running at Top Performance for years to come.

### What's the difference between traditional water softener and FUTURA Salt Free Anti-Scale Water Softener/Conditioner?

**1) Sodium content will not increase:** The traditional water softener operates on the basis of ion exchange. Ion Exchange resins remove calcium and magnesium ions from water, and replace these with sodium ions. These traditional ion exchange softeners produce salty water - Intake salty water increase risks for the cardiovascular system. Also, due to negative impacts to the environment, many local cities have banned the use of traditional salt-based systems.

**2) No salt and no regeneration:** When the Ion Exchanger is depleted, it requires water for backwashing and must be regenerated using salt or potassium chloride. A drain must be installed to Discharge the salty water and minerals.

Since FUTURA Water Conditioner is a pure catalytic process, the water hardness is transformed into firm lime crystals. When the calcite crystals reach a size in the range of nano-meters, they detach from the resin-plated template and are carried away by the water flow. The media is not used up in the process; therefore, no regeneration or salt is needed.

**3) No Control head required, so no need for periodic maintenance:** Traditional ion exchange units require a control head, it is an additional ongoing maintain cost. In contrast, FUTURA Water Conditioner is a simple in-out valve for water to flow.

**4) No need to backwash:** Because the FUTURA media is continually in motion in the counter-current, and no particles are held up in granulate, a backwashing process is not required. A central control valve is therefore not needed.

**5) No maintenance costs:** The estimated expense to purchase and replace the salt is about \$100 to \$400 per year, and most traditional water softeners use an Electronic Control Head, which will result in monthly energy expenses.

**6) No slippery feeling that you have with the traditional softener:** Because the water hardness was not removed or replaced with sodium ions, you will not have the slippery feel like using the traditional water softener. The water hardness is crystallized.



## **How FUTURA media prevents scale or remove existing scale?**

Negative calcium and magnesium ions in the existing scales are attracted to the neutral calcium and magnesium crystal clusters. The neutral calcium and magnesium crystals will not attach to any kind of surface. Because ions are formed into stable calcium and magnesium crystals and floating in the water from the FUTURA Conditioner, existing scale is usually reduced or eliminated within 1 to 2 months.

Depending on the thickness of the existing scale, it will take some weeks to remove 100% of the scale buildup. But after this, the pipe system and the heat exchanger surfaces will be absolutely clean. During these weeks, customers may experience a salty taste or light odor in the water for a short period of time. This happens because the FUTURA Water Conditioner is cleaning the pipes that may have a sodium and/or calcium build up in the pipes. This will last for a short time until the pipes are clean.

## **What is the effect of using a FUTURA Water Conditioner on rusted water pipes?**

In older pipe systems and the areas where high water hardness is a problem, significant lime deposits have often formed in the interior of water pipes. These in turn often contain rust particles and other corrosive products. When these lime deposits are broken down using the FUTURA Water Conditioner, released rust can come out of water faucets and possibly plug aerators and showerheads for a while.

This problem can best be solved by occasionally cleaning the parts, or replacing the rusted pipes.

## **Do I need to clean the media?**

The media does not need to be cleaned prior to installation. However, we do recommend soaking the media with water for 15-20 minutes before installation.

## **Do microorganisms accumulate in the media and must be regularly be disinfected?**

No. The media does not demonstrate any filtration effects. When in service, the media is always suspended in the water and therefore microorganisms are repressed. The continuous backwash is the best action to keep the media clean; therefore, disinfecting the media granulate in most cases is not required.

The media nevertheless can be treated with chlorine (up to 2-3 ppm) to kill any bacteria and remove organic matter. Please contact our technicians for detailed instructions.

## **What happens at night when there is no water flow?**

The media bed is not suspended when there is no water flow. The media bed will rest. It is recommended to allow the media bed to rest every 8 hours. This is never a problem in residential applications because you have at least 8 hours when the water is not flowing.



## Why does FUTURA function only up to 25 grains of hardness?

This value is based upon the required amount of media, and in most cases (about 80%), the water hardness is below 25 grains.

Units that function successfully with maximum 25 grains of hardness, are valued based upon the required amount of media granulate.

## How can I test the media? Can I use a conductivity meter? What results tell me that the system is working?

Depending on the flow rate (and the contact time) the pH may decrease by 0.5 units and the TDS value is reduced significantly. When hardness is falling out of solution into a hard crystal form, you get the lower TDS reading. You may experience TDS reductions between 10 to 20% depending on the contact time and depending on the original TDS value.

You can witness a convincing result by trying the following method. First, you need to prepare two saucepans and place them on a heater. Fill one Saucepan with the untreated water and the other Saucepan with water treated by the FUTURA Water Conditioner. As the water boils down the untreated water, water will build a hard scum on the side of the saucepan. The saucepan with treated water will have no hardness scum on the side. You may see a circulation of hardness crystals on the bottom of the pan just before the water is boiled out. The residual white spot can easily be wiped off with a towel.

You can also observe the heating equipment and appliances that were already covered with scales. A few days after installing the FUTURA Water Conditioner, you will notice that any existing white scale will begin to disappear, and appliances will soon be free of new scale buildup.

## What is the composition of the media?

Composition/Information on Ingredient		Weight (%)
Ceramic	Not Hazardous	15
Modified acrylic copolymer	Not Hazardous	85

No other media can be combined with the FUTURA Salt-Free AntiScale Water Softener products.

Media is certified by the Water Quality Association (WQA) to NSF/ANSI-61 for health effects to daily water usage.

### **What is the maximum operating temperature of the FUTURA media?**

This material of the media is considered stable under specified conditions of usage. The FUTURA media will tolerate feed water temperature in between 41-120° F. However, avoid repeated freeze-thaw cycles; beads may fracture. If frozen, thaw at room temperature.

### **What is the pH range of the media? What is the low and high pH range?**

The Media works in a range of 6 to 9 pH, and is highly recommended to be used at that range to avoid any malfunction to the system.

However, we also found that it works at 5.5 pH as well. (We always recommend that you do a pilot to find out if your water is below 6 pH).

### **How can I destroy the media or can it get fouled? What special precautions should I take?**

Hydrogen sulfide, concentrated nitric acid, and oil in the water can foul the media. No special precautions is needed, as the media is not hazardous, so skin contact with the media is harmless.

### **Why do I occasionally get water spots on my dishes using the dishwasher?**

Many commercial dishwashing detergent products contain toxic chlorine and harsh phosphates, which will sometimes cause water spots even when a water softener is used.

We highly recommend using the Automatic Dishwashing Detergents by Seventh Generation. This special detergent uses a unique nontoxic polymer formula, and is free of toxic chlorine and harsh phosphates, leaving dishes and glassware spotless in an eco-friendly way. We have found that the Seventh Generation detergents works perfect with our Futura Softener.

This detergent can be found at most grocery stores or online.

### **When and how should I replace the media that is in the mineral tank?**

The media is strong and can last for 5 years or 600,000 gallons with normal usage. After its estimated useful life, you can just simply replace the old media with new media.

To replace the media, you will need to unscrew the tank head and pull out the tank head assembly. Then, pour out the old media and refill with the new media.

**\*\*\* End of FUTURA Maintenance \*\*\***

## WARRANTY POLICY

For a period of ten years from the date of original purchase, APEC will replace any part of the water softener that APEC finds to be defective in operation due to faulty materials or workmanship with the exception of the replaceable media, which shall be prorated. The customer pays only for shipping. Service schedule depends on local input water quality.

Damage to any part of this water softener because of misuse, misapplication, negligence, alteration, accident, installation or operation contrary to our instructions, incompatibility with accessories not installed by APEC, or damage caused by freezing, flood, fire, or Act of God, is not covered by this warranty. In all such cases, regular charges will apply. This warranty is void if the unit is not operated under normal operating conditions as the unit is intended for.

We assume no warranty liability in connection with this water softener other than specified herein. This warranty is in lieu of all other warranties, expressed or implied, including warranties of fitness for a particular purpose. We do not authorize any person or representative to assume for us any other obligations on the sale of this water softener.

This warranty becomes effective when the system is installed correctly and used properly. This water softener unit has been inspected and approved at our factory. Through this warranty we are demonstrating our confidence in APEC products.

### Copyright:

This manual is copyrighted by APEC Inc. Under the copyright laws, this manual may not be reproduced in any form, in whole or part, without the prior written consent of APEC Inc. Manual print ver.1.6, 2018 May.



**Advanced Purification Engineering Corp.**

1320 S Johnson Drive  
City of Industry, CA 91745

*For questions or comments please visit our website at:*

**[www.FreeDrinkingWater.com](http://www.FreeDrinkingWater.com)**

*For technical support contact us at:*

**Techsupport@freedrinkingwater.com**  
**1-800-880-4808**