



# VINCENNES

## SINGLE HANDLE TUB & SHOWER FAUCET

### Model

---

MFF-VCNTS

### Available Finishes

---

Brushed Nickel (BN)  
Chrome (CP)

### Standards

---



- IAPMO UPC/cUPC
- NSF 61-9

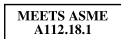

- ASME A112.18.1



- ADA Accessibility Guidelines for Buildings and Facilities 4.27.4 Controls and Mechanisms

### General Description

---

Cast brass valve body. Washerless disc cartridge. Zinc lever handle. Brass escutcheon. Plastic diverter tub spout  
Plastic 1-function shower head. 1/2" IPS connections  
Shower head max. flow rate: 2.5 gpm (9.5 lpm) minimum at 80 PSI. Tub spout min. flow rate: 2.4 gpm (9.1 lpm) maximum at 20 PSI



### Product Features

---

- Washerless Valve Cartridge
- Cast Brass Valve Body (MFF-TBSHW-VL)
- Metal Lever Handle
- Includes Diverter Tub Spout
- 100% Factory Pressure Tested

### Suggested Specification

---

Tub & shower faucet shall feature cast brass valve body. Shall also feature 120° turn washerless ceramic disc valve cartridge. Includes diverter tub spout. Fitting shall be Fontaine Model #MFF-VCNTS-\_\_\_\_.

# VINCENNES

## SINGLE HANDLE TUB & SHOWER FAUCET

### Flow Rate

Showerhead max. flow rate: 2.5 gpm (9.5 lpm) at 80 PSI  
 Tub spout min. flow rate: 2.4 gpm (9.1 lpm) at 20 PSI

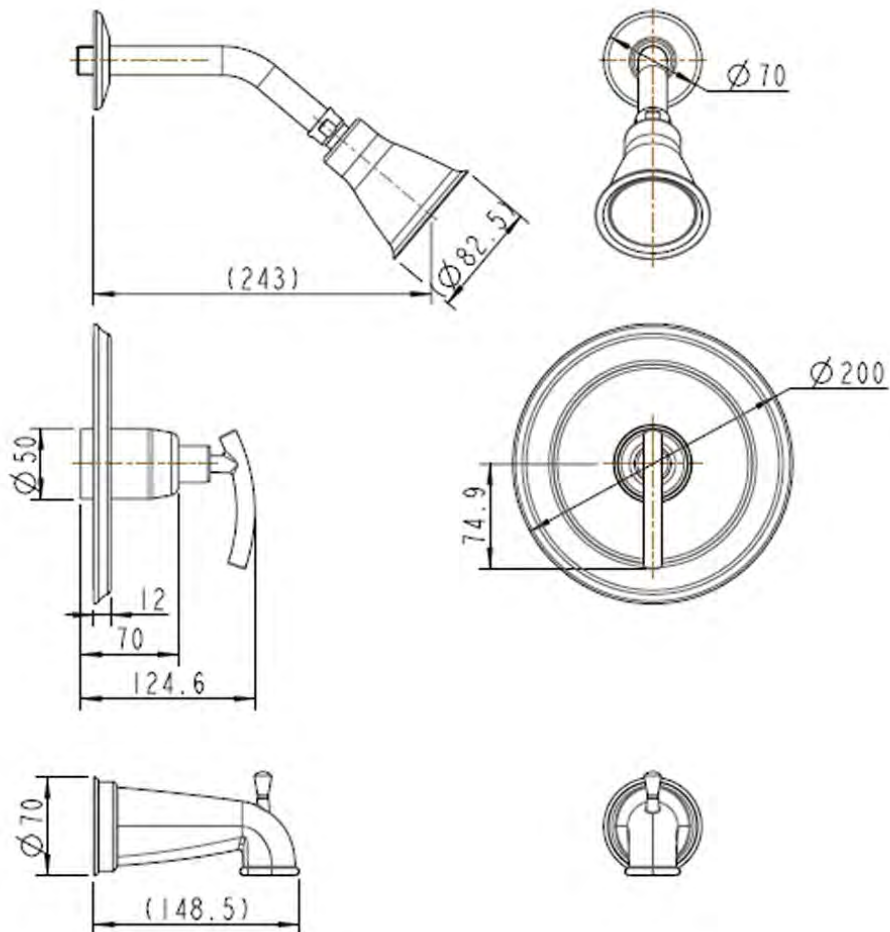
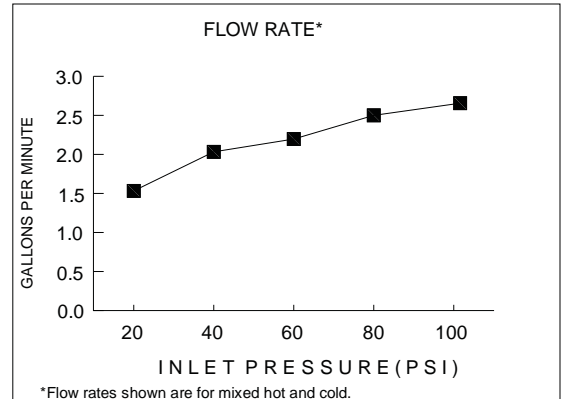



# TUB AND SHOWER VALVE

PRESSURE BALANCED

## Model

MFF-TBSHW-VL



## Standards



- IAPMO UPC/cUPC
- NSF 61-9
- ASSE 1016

## Product Features

- Washerless Valve Cartridge
- Cast Brass Valve Body

## General Description

Pressure balanced tub and shower valve. Brass body. Washerless cartridge. Two (2) .5 in. NPT outlets. Check valves included to prevent backflow or stop inlets, if necessary.

## Suggested Specification

Pressure balanced tub and shower valve shall feature cast brass valve body. Shall also feature washerless valve cartridge. Fitting shall be Fontaine Model #MFF-TBSHW-VL.

