

Arria Antique Bronze Cast Aluminum Bistro Set Item#: 61490



**ATTACH YOUR  
RECEIPT HERE**

Keep a copy of your proof of purchase or order confirmation which will be needed if you need to contact us about warranty coverage.

Purchase Date: \_\_\_\_\_



**SAVE THESE  
INSTRUCTIONS FOR  
FUTURE REFERENCE.**



**Questions, problems, missing parts?**

Before returning to your retailer, our exceptional customer service is available.

Call toll-free (866) 985-7877 9 a.m. – 9 p.m., EST  
Email [cservice@welltraveled.net](mailto:cservice@welltraveled.net)  
Live chat [www.wtliving.com](http://www.wtliving.com) 9 a.m. – 4 p.m., EST, Monday – Friday



## BEFORE YOU BEGIN

Before beginning assembly, make sure all parts are present. Compare parts received with the “Parts List.” If any part is missing or damaged, do NOT attempt to assemble the product. Please read and understand this entire manual before attempting to assemble, operate or install this product. If you have any questions regarding the product, please contact customer service.



## GENERAL INFORMATION

Your new patio furniture is made from the finest materials available. It should provide many years of enjoyment with minimal care.

Keep your patio furniture clean and apply a coat of wax a few times a year. For best results, clean the patio furniture with warm soapy water and use an outdoor furniture wax. If you use furniture covers, always make sure the furniture is clean and completely dry before covering as mold may form in dark, wet places. Check the bolts on your patio furniture regularly to make sure they are tight.

To provide a rust free product, this patio furniture is made of Cast Aluminum which is a relatively soft material. Be careful not to over-tighten your hardware. Stripped hardware is not covered under the manufacturer’s warranty. The weight limit for each seat is 225 lbs.



## SAFETY INFORMATION

### WARNING

DO NOT stand or allow children to stand on the assembled product. DO NOT tighten bolts completely until instructed to do so. After final alignment, make sure all nuts and bolts are securely fastened. NEVER use a power tool to assemble or tighten your furniture. Perform periodic checks to make sure the hardware is secure and tighten if needed.

### CAUTION

READ all instruction before beginning assembly. Failure to do so may result in faulty assembly and potential injury. Assemble the items on a soft, non-abrasive surface such as a carpet or cardboard to avoid damaging the item.

# PARTS LIST

# BALKENE —HOME—

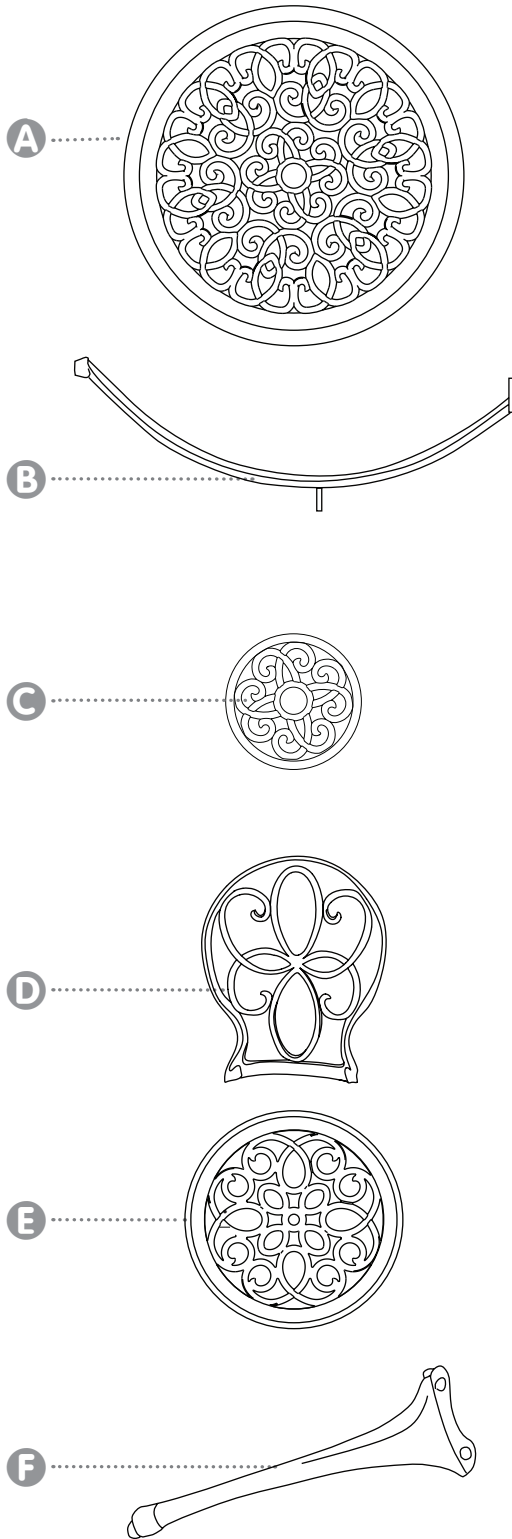

PART	DESCRIPTION	QUANTITY
<b>A</b>	Table Top	1
<b>B</b>	Table Leg	3
<b>C</b>	Leg Support	1
<b>D</b>	Back Rest	2
<b>E</b>	Seat	2
<b>F</b>	Chair Leg	8



## HARDWARE CONTENTS

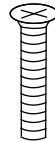

**G**

**6x35mm Bolt**  
**Qty: 7**  
*(6 for assembly + 1 extra)*

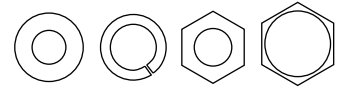

**H**

**Washer/Spring Washer/  
Nut/Plastic Cap (8mm)**  
**Qty: 24**  
*(23 for assembly + 1 extra)*

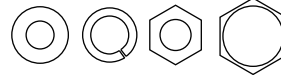
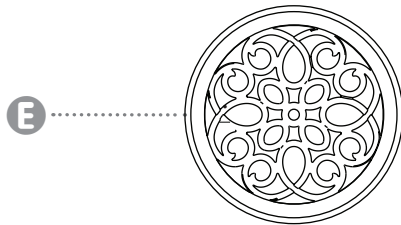
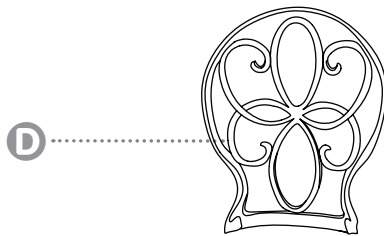
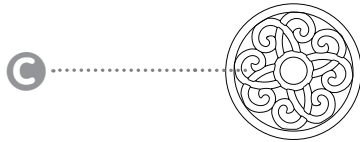

**I**

**Washer/Spring Washer  
/Nut/Plastic Cap (6mm)**  
**Qty: 7**  
*(6 for assembly + 1 extra)*



**J**

**8x30mm Stud**  
**Qty: 4**  
*(3 for assembly + 1 extra)*

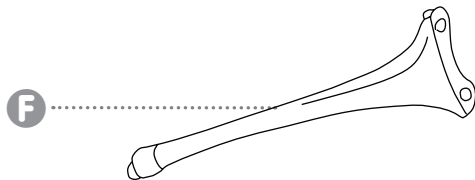

**K**

**Wrench**  
**Qty: 1**



**L**

**Adjustable Foot**  
**Qty: 11**  
*(Pre-Installed)*

# ASSEMBLY

# BALKENE —HOME—



## PREPARATION

Before beginning assembly, be sure to empty contents of carton and make sure all parts are present. If any parts are missing, please contact Customer Service at (866)-985-7877, Monday-Friday, 9 a.m. - 6 p.m. EST or email at [cservice@welltraveled.net](mailto:cservice@welltraveled.net).

Place all parts on a soft, level surface for assembly. Estimated Assembly Time: 30 Minutes | DO NOT over tighten hardware!

## TABLE ASSEMBLY

**1** Lay the **Table Top A** upside down on a nonabrasive, level surface. Affix **3 Studs J** into the underside of the **Table Top**.



Hardware Used:

**J** 8x30mm Stud x3

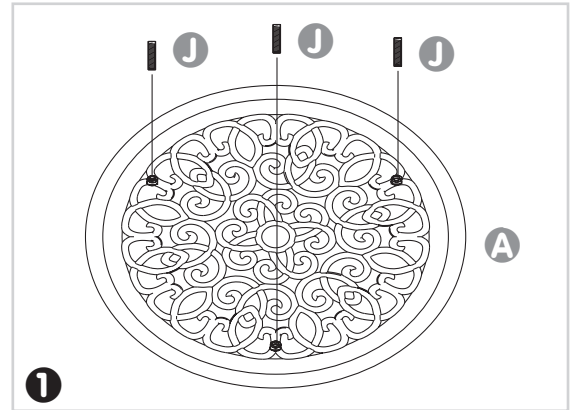

**2** Fit the **3 Legs B** over the **Studs J** and secure in position using **3 Washers/Spring Washers/Nuts H** (In that order). DO NOT OVERTIGHTEN.



Hardware Used:

**H** 8mm Washer/Spring Washer/Nut x3

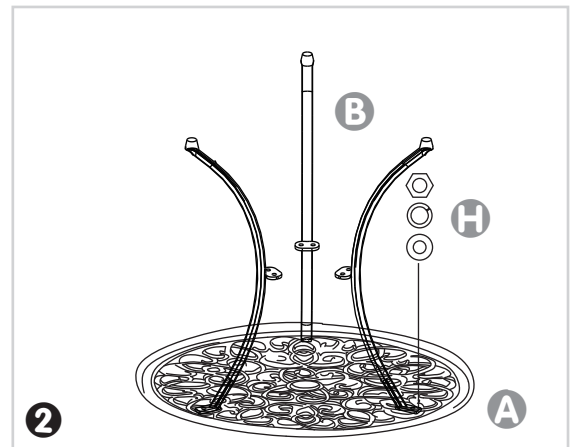

**3** Turn the assembled **Table Top/Legs** over. Position the round **Leg Support C** on top of the 3 leg brackets. Attach the **Leg Support** to the **Legs B** using a **Bolt G** through of the 6 holes on the **Leg Support** and through the holes on each leg bracket. Place **Washer/Spring Washer/Nut I** (in that order) over the end of each **Bolt**. DO NOT OVERTIGHTEN.



Hardware Used:

**G** 6x35mm Bolt x6

**I** 6mm Washer/Spring Washer/Nut x6

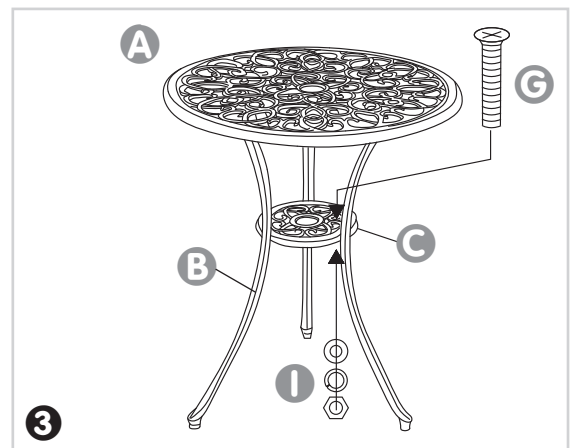

## CHAIR ASSEMBLY

**4** Attach the **Chair Back D** to the **Seat E** by inserting the pre-installed studs at the base of the **Chair Back** into the holes on the **Seat**. Secure with a **Washers/Spring Washers/Nuts H** (in that order) on each stud.

 **Hardware Used:**  **8mm Washer/Spring Washer/Nut x2**

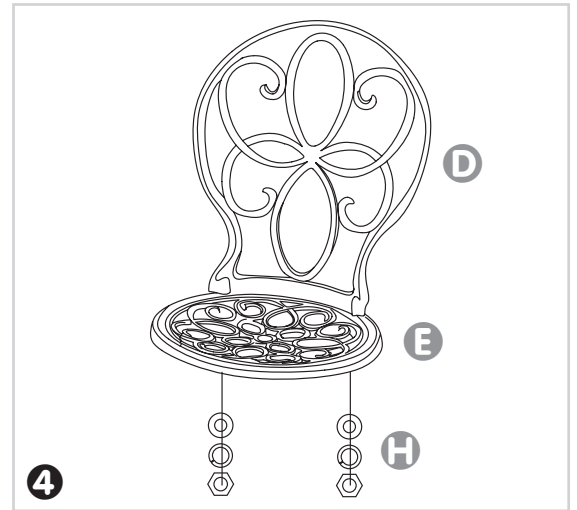

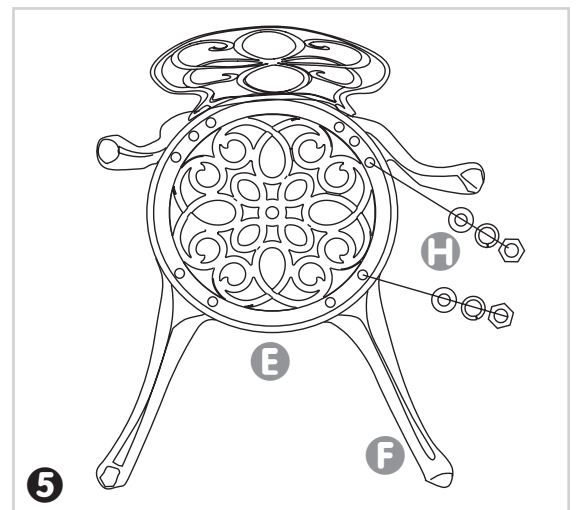

**5** Turn the seat upside-down. Attach the **Chair Legs F** to the **Seat E** by inserting the pre-installed studs on the bottom of the **Seat** into the holes at the top of each **Chair Leg**. (*HINT: Begin with REAR legs, then attach FRONT legs.*) Secure each **Leg** with 2 sets of **Washers/Spring Washers/Nuts H** (in that order). **DO NOT OVERTIGHTEN.**

 **Hardware Used:**  **8mm Washer/Spring Washer/Nut x8**



**6** Repeat Steps 4 and 5 to assemble second chair. Adjust the pre-installed **Rubber Feet L** until the Bistro Set sits level on the ground. Check **ALL Nuts** on table and chairs for tightness and adjust as necessary using **Wrench K**. Lastly, cover all **Nuts** with **Plastic Caps H/I**.

Your Bistro Set is ready for use!

 **Hardware Used:**  **Plastic Cap x23**  
 **Plastic Cap x6**



# BALKENE

—HOME—



## LIMITED WARRANTY

Customers in the Contiguous US

This product is warranted for a period of 1 year from original purchase date against defects in materials and workmanship under normal use. This warranty does NOT cover normal wear/weathering, exposure to water, freezing temperatures, oils, fluids, or chemicals OR use in a commercial context if the unit is not designated as a commercial model. At Well Traveled Living's sole discretion, products under warranty will be repaired and/or replaced at no charge to the customer. Returns sent back to Well Traveled Living must be sent via prepaid freight in the original retail packaging.

For warranty service, contact Well Traveled Living at the address, phone numbers or website and email listed in this owner's manual. Be sure to have your sales receipt, date of purchase and catalogue/model numbers available when calling. All warranty service will be coordinated by Well Traveled Living's, Amelia Island, Florida service center. This warranty is extended only to the original owner. Proof of purchase will be required before warranty service is rendered. The sales receipt is the only valid proof of purchase. This warranty only covers failures due to defects in materials or workmanship which occur during normal use. Failures and/or damage which result from accident, negligence, misuse, abuse, neglect, mishandling, alteration or modification, failure to maintain, improper assembly or maintenance, service by unauthorized agency or use of unauthorized components or damage that is attributable to acts of God are NOT covered.

This limited warranty gives you specific legal rights and you may also have other rights which vary from jurisdiction to jurisdiction. The provisions of the United Nations Convention on Contracts for the Sales of Goods shall not apply to this limited warranty or the sale of products covered by this limited warranty.

- THERE ARE NO EXPRESS WARRANTIES EXCEPT AS LISTED.
- PURCHASER ASSUMES ALL RISKS IN THE ASSEMBLY AND OPERATION OF THIS UNIT.
- FAILURE TO FOLLOW WARNINGS AND OPERATIONAL INSTRUCTIONS CONTAINED IN THIS MANUAL CAN RESULT IN SEVERE PROPERTY DAMAGE AND/OR PERSONAL INJURY.
- IN NO EVENT WILL WELL TRAVELED LIVING, OR ITS DIRECTORS, OFFICERS OR AGENTS BE LIABLE TO THE PURCHASER OR ANY THIRD PARTY, WHETHER IN CONTRACT, IN TORT, OR ON ANY OTHER BASIS, FOR ANY INDIRECT, SPECIAL, PUNITIVE, EXEMPLARY, CONSEQUENTIAL, OR INCIDENTAL LOSS, COST, OR DAMAGE ARISING OUT OF OR IN CONNECTION WITH THE SALE, MAINTENANCE, USE, OR INABILITY TO USE THE PRODUCT, EVEN IF WELL TRAVELED LIVING OR ITS DIRECTORS, OFFICERS OR AGENTS HAVE BEEN ADVISED OF THE POSSIBILITY OF SUCH LOSSES, COSTS OR DAMAGES, OR IF SUCH LOSSES, COSTS, OR DAMAGES ARE FORESEEABLE. IN NO EVENT WILL WELL TRAVELED LIVING, OR ITS OFFICERS, DIRECTORS, OR AGENTS BE LIABLE FOR ANY DIRECT LOSSES, COSTS OR DAMAGES THAT EXCEED THE PURCHASE PRICE OF THE PRODUCT.
- SOME JURISDICTIONS DO NOT ALLOW THE EXCLUSION OR LIMITATION OF INCIDENTAL OR CONSEQUENTIAL DAMAGES, SO THE ABOVE LIMITATION OR EXCLUSION MAY NOT APPLY TO THE PURCHASER.

## EXTEND YOUR WARRANTY

When you purchase a Fire Sense or Balkene Home product, you'll have peace of mind in knowing that it comes with a one-year warranty. Extend your warranty for *an additional year* when you write a review of your purchase on [www.wtliving.com](http://www.wtliving.com) within 365 days of purchase.



### Important Notice

Do NOT return to place of purchase—for customer service and warranty issues:

Call toll-free	<b>(866) 985-7877</b>	9 a.m. – 9 p.m., EST
Email	<b><a href="mailto:cservice@welltraveled.net">cservice@welltraveled.net</a></b>	
Live chat	<b><a href="http://www.wtliving.com">www.wtliving.com</a></b>	9 a.m. – 4 p.m., EST, Monday – Friday

Distributed by:

Well Traveled Living

716 S 8th Street, Amelia Island, FL 32034

[wtliving.com](http://wtliving.com) | [cservice@welltraveled.net](mailto:cservice@welltraveled.net)

(866) 985-7877