

HZ202100TX

Dayne Bar Cart

Assembly Instructions



Southern
ENTERPRISES







For assistance with assembly contact:
Southern Enterprises, Inc.
Customer Service 1-800-633-5096
service@seidal.com
www.seidal.com

PO# :

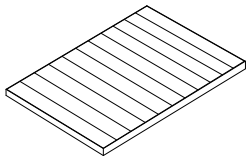
Dayne Bar Cart

Parts List

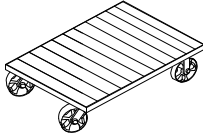
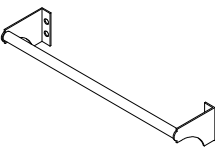
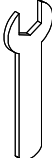
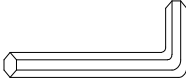
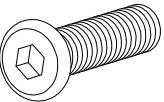
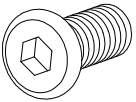
Please check packaging for all parts and hardware before discarding. Unpack and lay parts on clean, padded surface like carpet or blanket. Check that you have all parts indicated. Call customer service if hardware is missing. Before beginning assembly, carefully study the diagrams below and sort your hardware according to the pictures. Using the incorrect hardware will cause damage.

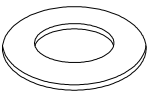
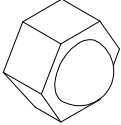
<p>A. Quantity of 1</p>  <p>Top Panel</p>	<p>B. Quantity of 1</p>  <p>Left Back Leg</p>	<p>C. Quantity of 1</p>  <p>Left Front Leg</p>
<p>D. Quantity of 1</p>  <p>Right Back Leg</p>	<p>E. Quantity of 1</p>  <p>Right Front Leg</p>	<p>F. Quantity of 1</p>  <p>Bottom Panel with Caster</p>
<p>G. Quantity Of 1</p>  <p>Handrail</p>	<p>H. Quantity Of 1</p>  <p>Wrench</p>	<p>1. Quantity of 1</p>  <p>Allen Wrench</p>
<p>2. Quantity Of 8</p>  <p>Bolt Ø 5/16"x1"L</p>	<p>3. Quantity of 4</p>  <p>Bolt Ø 5/16"x1/2"L</p>	<p>4. Quantity of 12</p>  <p>Spring Washer Ø 5/16</p>
<p>5. Quantity of 12</p>  <p>Flat Washer Ø 5/16</p>	<p>6. Quantity of 4</p>  <p>Nut</p>	

Care and Cleaning Instructions:
 Before using, wipe with a clean, dry cloth. Periodically apply furniture wax to renew the finish. Avoid rubbing or scratching the surface with rough or abrasive objects.

For replacement parts or questions, please call customer service at 1-800-633-5096.

Assembly Tool Required No.2 Phillips Screwdriver (Not Included)

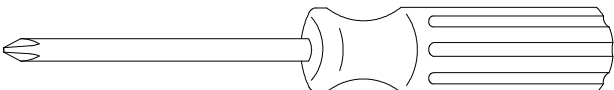

Dayne Bar Cart

Assembly Instructions

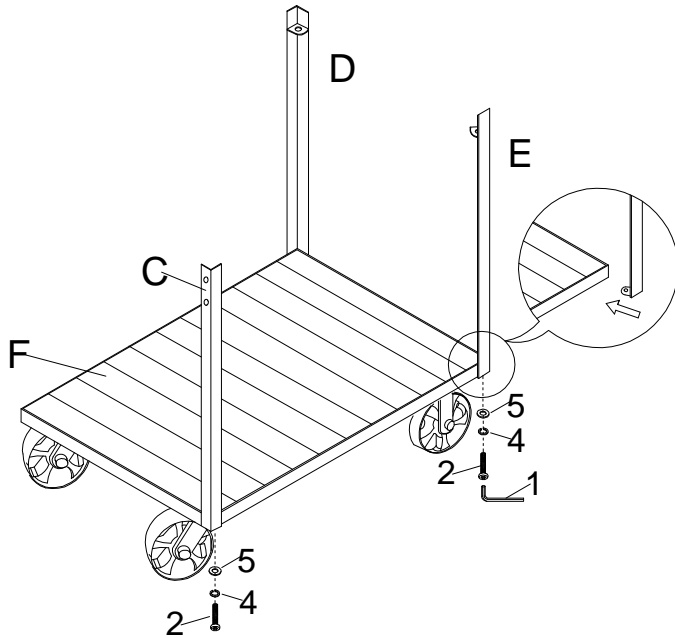

Figure 1

Attach three Legs (**C/D/E**) to Bottom Panel with Casters (**F**) using Bolts (**2**), Spring Washers (**4**) and Flat Washers (**5**).

Tighten all Bolts (**2**) by using Allen Wrench (**1**) as shown.

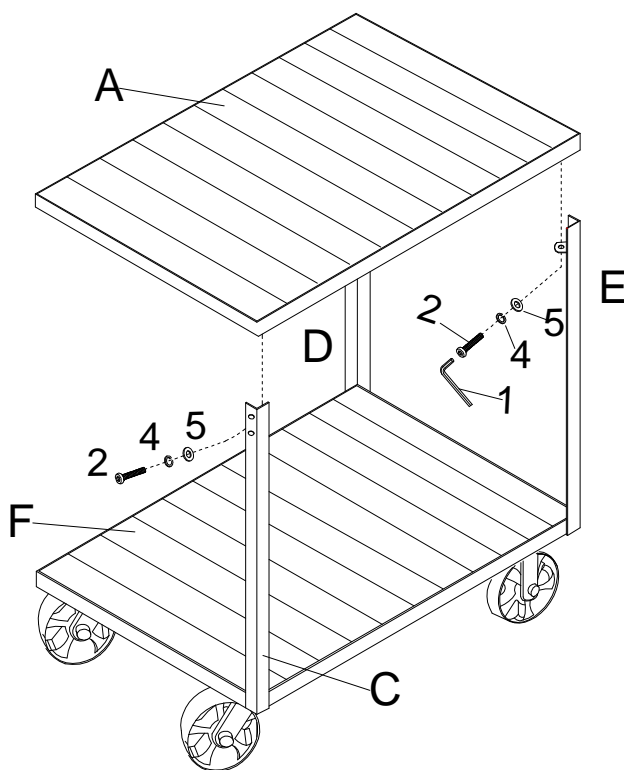

Figure 2

Attach Top Panel (**A**) to the assembled unit from Figure 1 with Bolts (**2**), Spring Washers (**4**) and Flat Washers (**5**).

Tighten all Bolts (**2**) using Allen Wrench (**1**) as shown.

Tip: It may be easier to lay the unit on its side in order to attach the Top Panel.

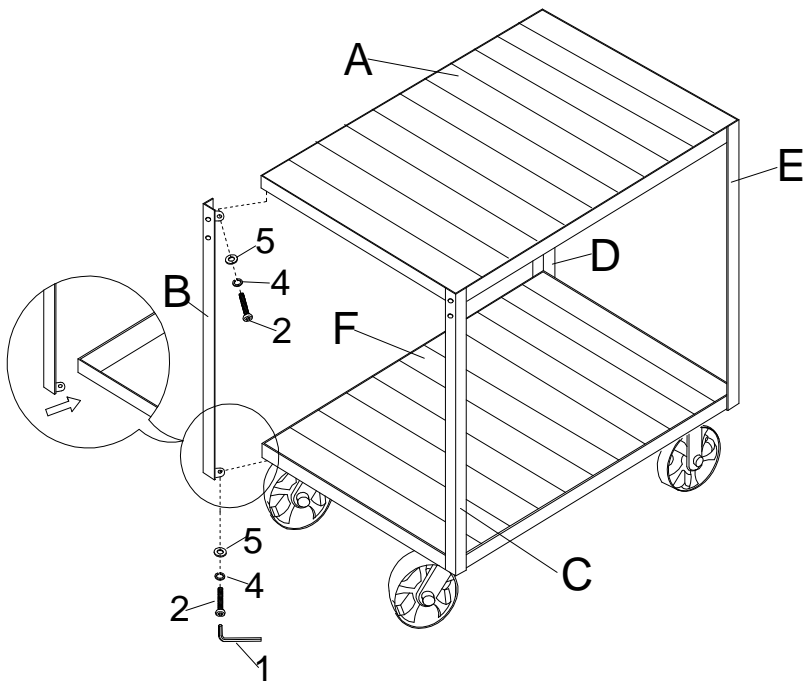
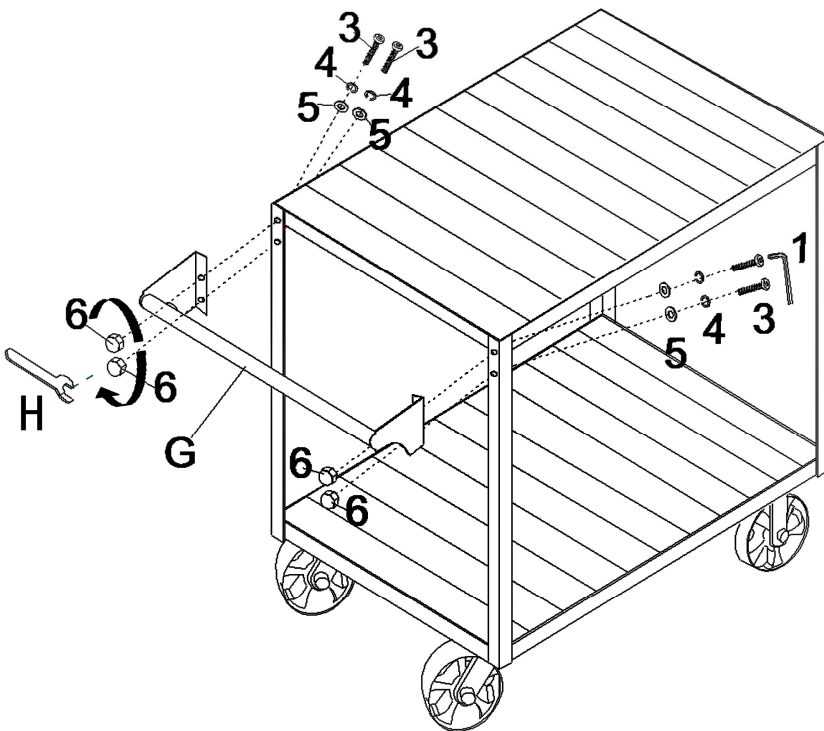

Figure 3

Attach the fourth Leg **(B)** to the assembled unit from Figure 2 using Bolts **(2)**, Spring Washers **(3)** and Flat Washers **(4)**.

Tighten all Bolts **(2)** using Allen Wrench **(1)** as shown.

Tip: It may be easier to lay the unit on its side in order to attach the Leg.



Attach Handrail **(G)** to the assemble unit from Figure 3 with Bolts **(3)**, Spring Washers **(4)**, Flat Washers **(5)** and Nuts **(6)**.

Tighten all Bolts **(3)** by using Allen Wrench **(1)** as shown.

Tighten nuts with Wrench **(H)** as shown.

Note: Bolts with Spring Washers and Flat Washers Should be inserted through the Legs, through the Handrail and into the Nuts.

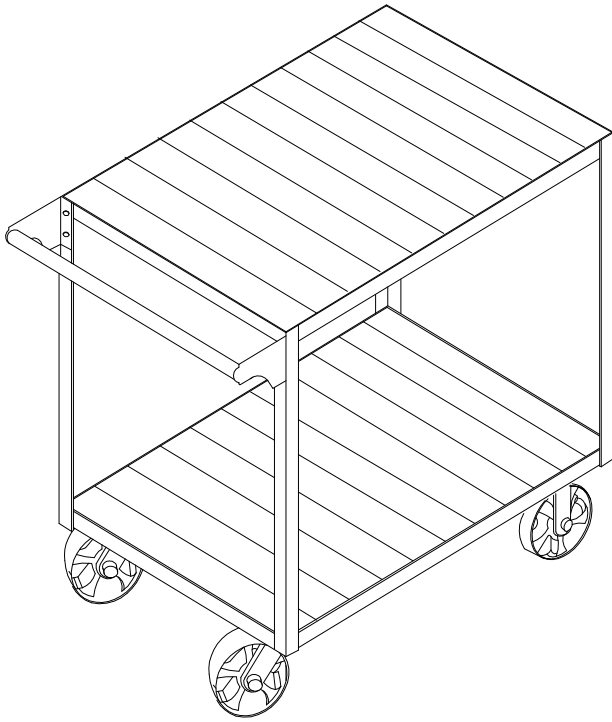

Figure 4

Now your Dayne bar cart is ready to use.

Parts Replacement Form

Customer Information

Name _____

Address _____

City/State/Zip Code _____

Phone Number _____

Please indicate where you purchased this item: Store/Website/Catalog

Please indicate color/size/style number:

Style No	Parts Letter	Parts Description	Quantity Needed
_____	_____	_____	_____
_____	_____	_____	_____
_____	_____	_____	_____

Please immediately examine this product carefully. Any request for missing parts or damage replacement must be received within 90 days of your receipt of the product. Replacement, if available, will be honored within this time frame. Parts will not be available for items arriving fully assembled. We do not recommend modifying product(s) and we are not responsible for any damages due to product modification(s). If damages or missing parts are not reported within 90 days of your receipt, we are under no obligation to provide parts or replacement merchandise.

Please contact Southern Enterprises at 800-633-5096 or in Dallas 972-869-0111/ 9am – 4pm Mon-Fri Central time if you have product issues or email us at service@seidal.com. Please ask for customer service representative for issues involving damages or replacement parts. Please ask for technical assistance representative for any issues with product and assembly/construction.

Please contact the retailer that you purchased from for returns.



Southern
ENTERPRISES

Customer Service 1-800-633-5096
service@seidal.com
Southern Enterprises, Inc.
600 Freeport Parkway, Suite 200
Coppell, Texas 75019