

MANOR BROOK™

Model # MB 98264

USE AND CARE GUIDE

TWIGS 1 LIGHT WALL SCONCE

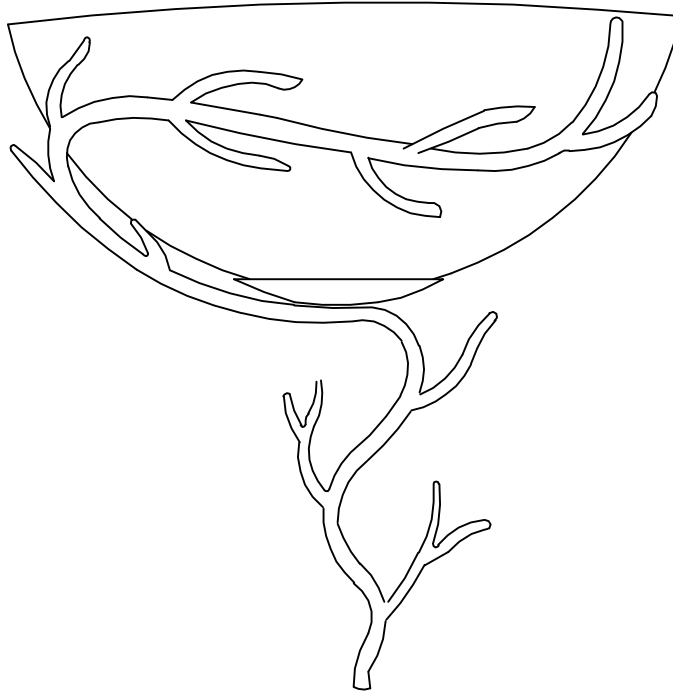

Questions, problems, missing parts? Before returning to the store,
call Manor Brook Customer Service
8 a.m.-6 p.m., EST, Monday-Friday

904-642-4340

THANK YOU

We appreciate the trust and confidence you have placed in Manor Brook through the purchase of this light fixture. We strive to continually create quality products designed to enhance your home.

Thank you for choosing us!

Table of Contents

Safety Information	2	Assembly	5
Warranty	2	Installation	5, 6
Pre-Installation	3	Care and Cleaning	7
Planning Installation	3	Troubleshooting	7
Tools Required	3		
Hardware Included	3		
Package Contents	4		

Safety Information

- Consult a qualified electrician with any electrical questions you may have.



IMPORTANT: Inspect the wire insulation for any cuts, abrasions, or exposed copper that may have occurred during shipping. If there is a defect in the wire, do not continue the assembly process. Please call our Customer Service Team at 904-642-4340.

Warranty

1-YEAR LIMITED WARRANTY

WHAT IS COVERED

The manufacturer warrants this lighting fixture to be free from defects in the materials and workmanship for a period of one (1) year from date of purchase. This warranty applies only to the original consumer purchaser and only to products used in normal use. If this product is found to be defective, the manufacturer's only obligation, and your exclusive remedy, is the repair or replacement of the product at the manufacturer's discretion, provided that the product has not been damaged through misuse, abuse, accident, modifications, alterations, neglect or mishandling. This warranty shall not apply to any product that is found to have been improperly installed, assembled, or used in any way not in accordance with the instructions supplied with the product. This warranty shall not apply to a failure of the product as a result of an accident, misuse, abuse, negligence, alteration, faulty installation, or any other failure not relating to faulty material or workmanship.

WHAT IS NOT COVERED

This warranty shall not apply to the finish on any portion of the product due to weathering, as this is considered normal wear. The manufacturer does not warrant and specifically disclaims any warranty, whether expressed or implied, other than the warranty contained herein. The manufacturer specifically disclaims any liability and shall not be liable for any consequential or incidental loss or damage, including but not limited to, any labor or expense costs involved in the replacement or repair of the product.

Contact the Customer Service Team at 904-642-4340.

Pre-Installation

PLANNING INSTALLATION

Read all instructions before assembly.

To avoid damaging this product, assemble it on a soft, non-abrasive surface such as carpet or cardboard. Inspect each part for defects that may have occurred during shipping.

Keep your receipt and these instructions for proof of purchase.



NOTE: This light fixture requires the use of one 120V, 60HZ, 100-Watt max, medium-base type A bulb (not included). Do not exceed the recommended wattage.

TOOLS REQUIRED



Safety goggles

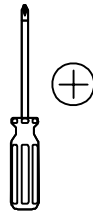

Phillips screwdriver

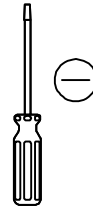

Flathead screwdriver



Pliers



Wire strippers



Wire cutters

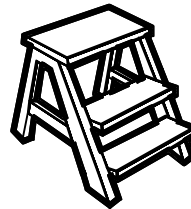

Ladder



Electrical tape

HARDWARE INCLUDED



NOTE: Hardware not shown to actual size.

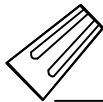

AA

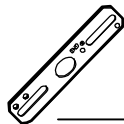

BB

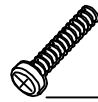

CC



DD



EE



FF



GG

Part	Description	Quantity
AA	Wire nut	3
BB	Cross bar	1
CC	Outlet box screw	2
DD	Ground screw	1
EE	Lock nut	1
FF	Nipple	1
GG	Finial	1

Pre-Installation (continued)

PACKAGE CONTENTS

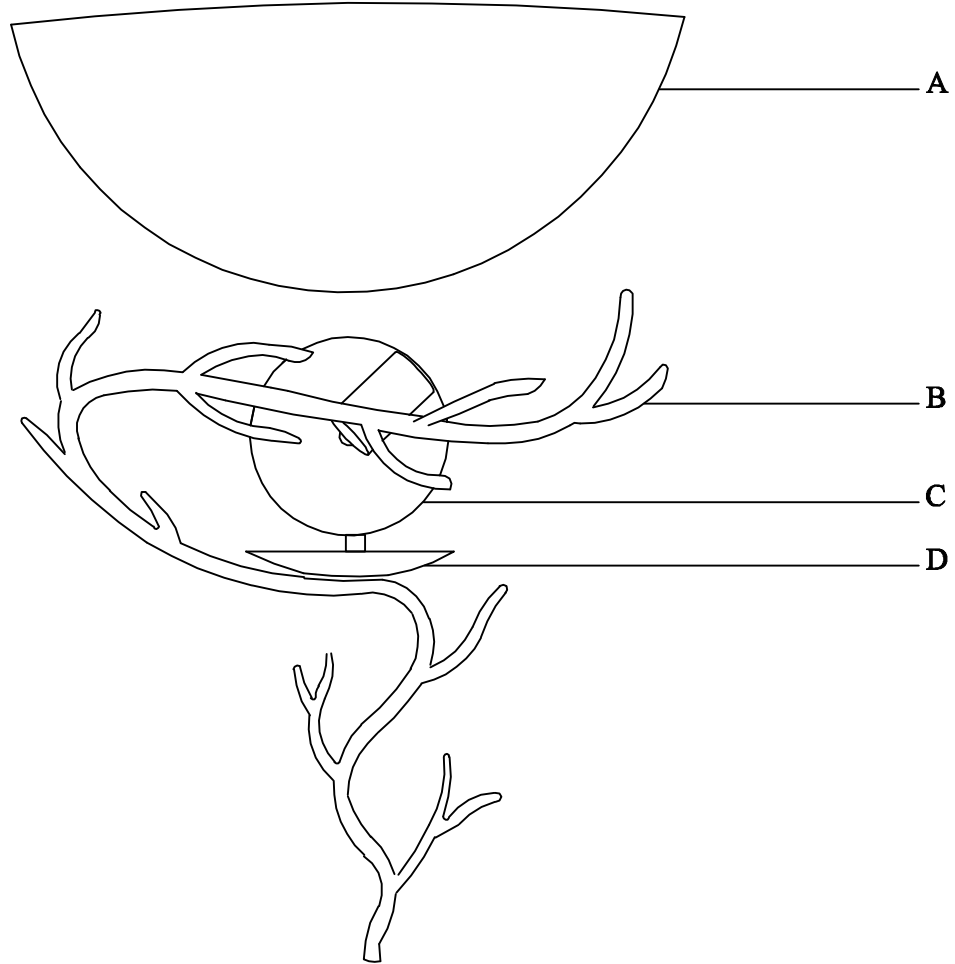

Part	Description	Quantity
A	Glass Shade	1
B	Fixture body	1
C	Backplate	1
D	Cup	1

Assembly

1 Assembling the light fixture

- Carefully unpack the fixture and lay out all parts on clean surface.

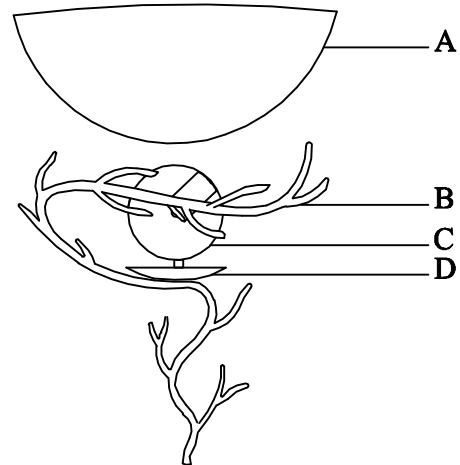

Installation

1 Installing the mounting plate



CAUTION: Ensure the power is off at the main fuse box prior to beginning installation.

- Turn off the switch at the wall.
- Turn the power off at the main fuse box.
- Screw the nipple (FF) into the hole in the cross bar (BB) and secure with a lock nut (EE).
- Attach the cross bar (BB) to the wall outlet box using the outlet box screws (CC).

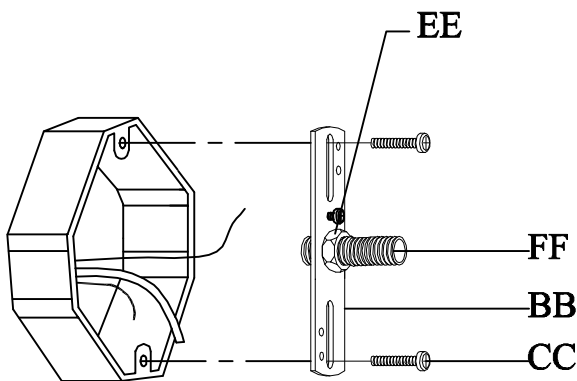

2 Connecting the wires

- Install the fixture bare copper ground wire (1) under the ground screw (DD) on the cross bar (BB).
- Connect the fixture ground wire (1) to the supply ground wires (2) in the outlet box using a wire nut (AA).
- Connect the white fixture wire (3) to the white supply wire (4) in the outlet box using a wire nut (AA).
- Connect the black fixture wire (5) to the black supply wire (6) in the outlet box using a wire nut (AA).

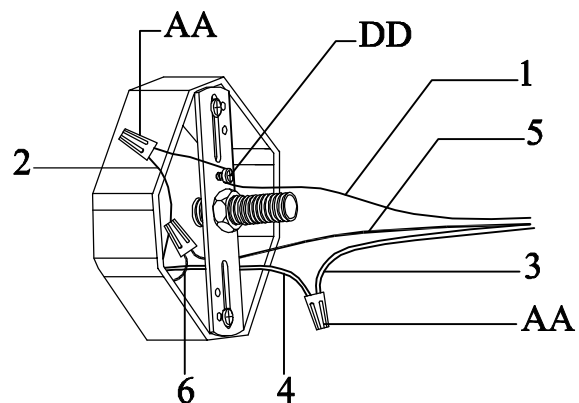

Installation (continued)

3

Hanging the light fixture

- Push all excess wires into the outlet box.
- Line up the hole of backplate (C) with the nipple (FF), and then secure the fixture body (B) to the wall with the finial (GG).

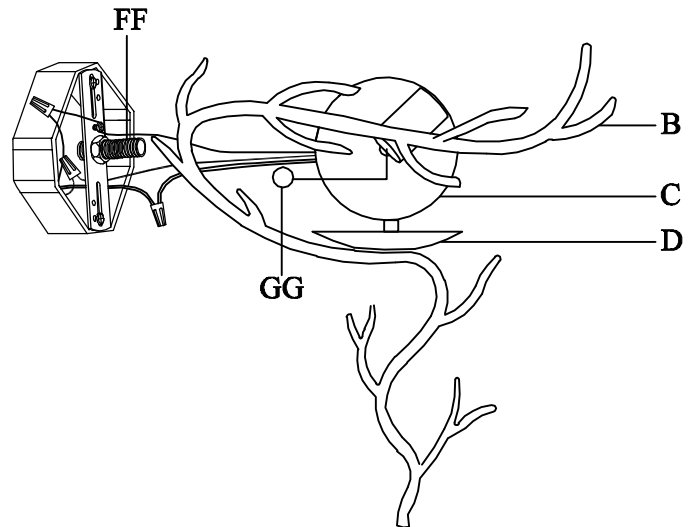

4

Assembling the glass shade

- Slide the glass shade (A) into fixture body (B) to let it sit on cup (D).

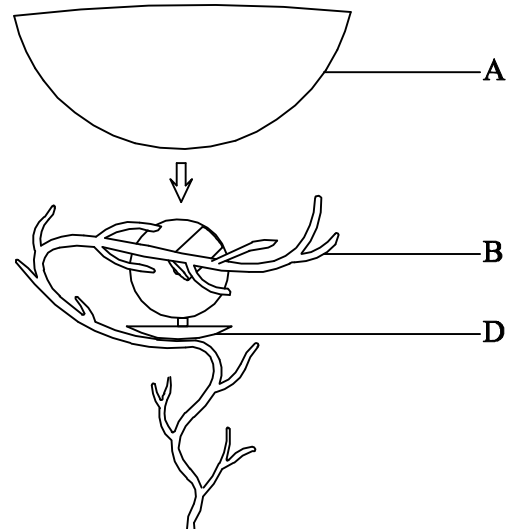

5

Installing the bulb

- Prior to installing the bulb, inspect socket for silica packet. If packet is present, then remove and throw away. Do not expose it to children or pets.
- Install the 120V, 60HZ, 100-watt max. medium-base type A bulb (not included) in the socket of the light fixture.

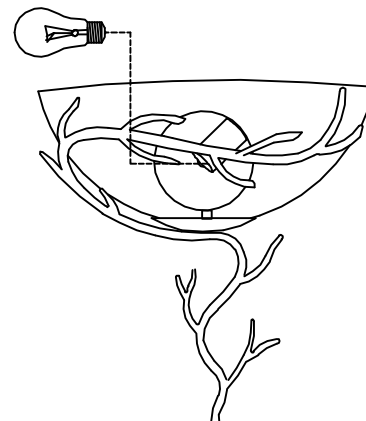

Care and Cleaning

Clean the light fixture with a soft, dry cloth. Do not use any cleaners with chemicals, solvents, or harsh abrasives.

Troubleshooting

Problem	Possible Cause	Solution
The bulb will not light.	<input type="checkbox"/> The bulb is burned out.	<input type="checkbox"/> Replace the light bulb.
	<input type="checkbox"/> The power is off.	<input type="checkbox"/> Ensure that the power supply is turned on.
	<input type="checkbox"/> There is a faulty wire connection.	<input type="checkbox"/> Check the wiring.
	<input type="checkbox"/> The circuit breaker is off.	<input type="checkbox"/> Ensure that the circuit breaker is set in the on position.
The fuse blows or a circuit breaker trips when the light is turned on.	<input type="checkbox"/> There is an exposed wire. <input type="checkbox"/> There are too many items on one circuit.	<input type="checkbox"/> Discontinue use of the light fixture. <input type="checkbox"/> Contact a qualified electrician or call the Customer Service Team at 904-642-4340. <input type="checkbox"/> Unplug other items on the circuit.

MANOR BROOK™

Questions, problems, missing parts? Before returning to the store,
call Manor Brook Customer Service
8 a.m.-6 p.m., EST, Monday-Friday

904-642-4340

Retain this manual for future use.