

# ASUNA

## *8580 VENTUS AIR MAGNETIC ROWER*

### *USER MANUAL*

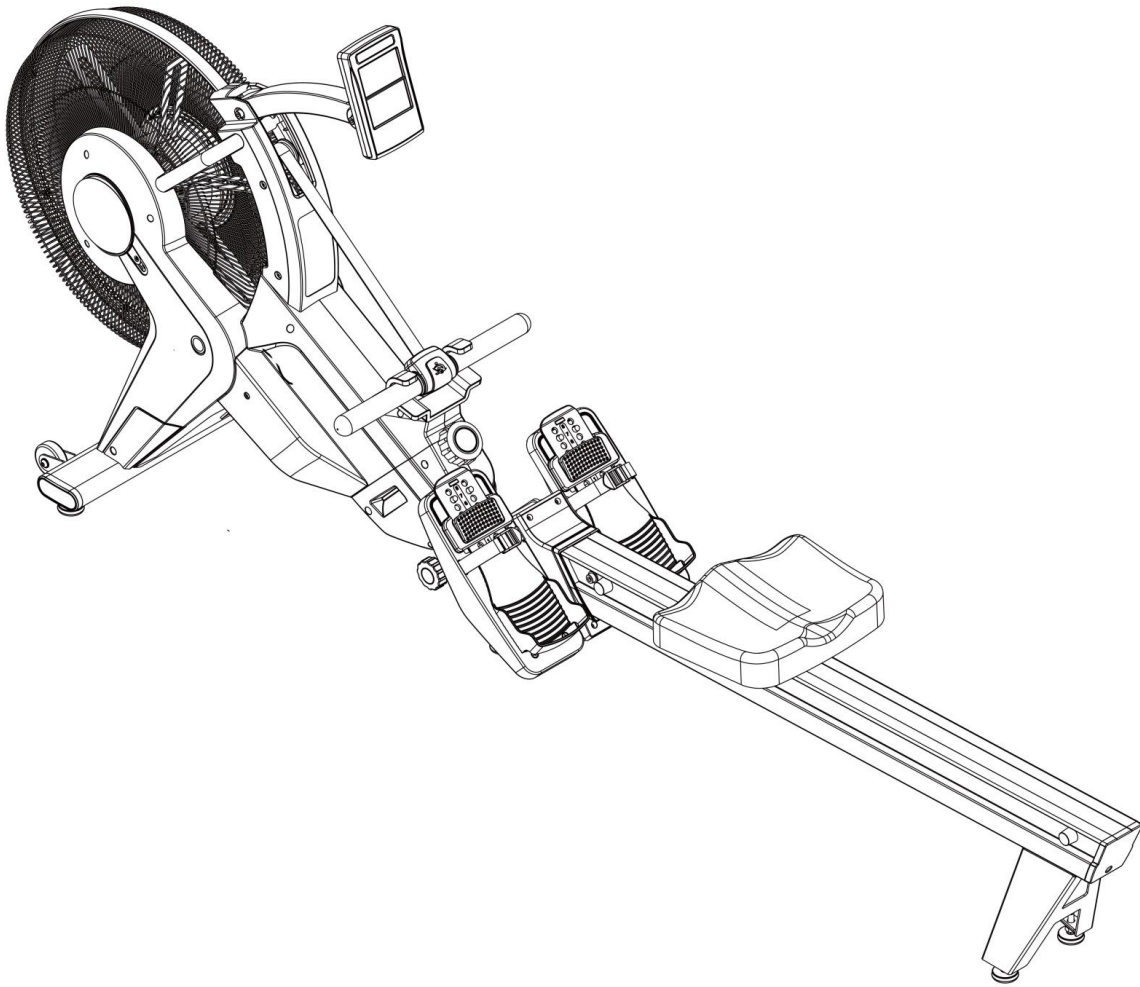

**IMPORTANT:** Read all instructions carefully before using this product. Retain owner's manual for future reference. For customer service, please contact: [support@sunnyhealthfitness.com](mailto:support@sunnyhealthfitness.com)

# IMPORTANT SAFETY INFORMATION

We thank you for choosing our product. To ensure your safety and health, please use this equipment correctly. It is important to read this entire manual before assembling and using the equipment. Safe and effective use can only be achieved if the equipment is assembled, maintained and used properly. It is your responsibility to ensure that all users of the equipment are informed of all warnings and precautions.

1. Before starting any exercise program you should consult your physician to determine if you have any medical or physical conditions that could put your health and safety at risk, or prevent you from using the equipment properly. Your physician's advice is essential if you are taking medication that affects your heart rate, blood pressure or cholesterol level.
2. Be aware of your body's signals. Incorrect or excessive exercise can damage your health. Stop exercising if you experience any of the following symptoms: pain, tightness in your chest, irregular heartbeat, shortness of breath, lightheadedness, dizziness or feelings of nausea. If you do experience any of these conditions, you should consult your physician before continuing with your exercise program.
3. Keep children and pets away from the equipment. The equipment is designed for adult use only.
4. Use the equipment on a solid, flat level surface with a protective cover for your floor or carpet. To ensure safety, the equipment should have at least 2 feet (60cm) of free space all around it.
5. Ensure that all nuts and bolts are securely tightened before using the equipment. The safety of the equipment can only be maintained if it is regularly examined for damage and/or wear and tear.
6. Always use the equipment as indicated. If you find any defective components while assembling or checking the equipment, or if you hear any unusual noises coming from the equipment during exercise, discontinue use of the equipment immediately and do not use until the problem has been rectified.
7. Wear suitable clothing while using the equipment. Avoid wearing loose clothing that may become entangled in the equipment. Do not use without shoes, or with loose shoes.
8. Do not place fingers or objects into moving parts of the exercise equipment.
9. The maximum weight capacity of this unit is 330 pounds (150 kgs).
10. The equipment is not suitable for therapeutic use.
11. Please take proper precautions when lifting and moving the equipment. Always use proper lifting technique and seek assistance if necessary.
12. For all adjustable parts be aware of the maximum position to which they can be adjusted.
13. Be aware of non-fixed or moving parts while mounting or dismounting the bike.
14. We take no responsibility for personal injury or damage sustained by or through the use of this exercise bike.

# WARM UP & COOL DOWN

The warming up is an important part of your workout. It should begin every session to prepare your body for more strenuous exercise by heating up and stretching out your muscles. Cool down at the end of your workout, repeat these exercises to reduce soreness in tired muscles. We suggest the following warm-up and cool-down exercises:

## HEAD ROLLS



Rotate your head to the right for one count, feeling the stretch up the left side of your neck, then rotate your head back for one count, stretching your chin to the ceiling and letting your mouth open. Rotate your head to the left for one count, then drop your head to your chest for one count.

## SHOULDER LIFTS



Lift your right shoulder toward your ear for one count. Then lift your left shoulder up for one count as you lower your right shoulder.

## SIDE STRETCHES



Open your arms to the side and lift them until they are over your head. Reach your right arm as far toward the ceiling as you can for one count. Repeat this action with your left arm.

## QUADRICEPS STRETCH



With one hand against a wall for balance, reach behind you and pull your right foot up. Bring your heel as close to your buttocks as possible. Hold for 15 counts and repeat with left foot.

## INNER THIGH STRETCH



Sit with the soles of your feet together and your knees pointing outward. Pull your feet as close to your groin as possible. Gently push your knees toward the floor. Hold for 15 counts.

## TOE TOUCHES



Slowly bend forward from your waist, letting your back and shoulders relax as you stretch toward your toes. Reach as far as you can and hold for 15 counts.

## HAMSTRING STRETCHES

Extend your right leg. Rest the sole of your left foot against your right inner thigh. Stretch toward your toe as far as possible. Hold for 15 counts. Relax and then repeat with left leg.

## CALF/ACHILLES STRETCH



Lean against a wall with your left leg in front of the right and your arms forward. Keep your right leg straight and the left foot on the floor; then bend the left leg and lean forward by moving your hips toward the wall. Hold, then repeat on the other side for 15 counts.

# PARTS AND ASSEMBLY INSTRUCTIONS

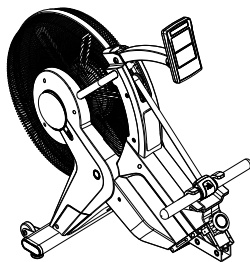

**Frame X1**  
**NO. 1**

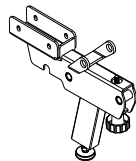

**Frame bracket set X1**  
**NO. 120**

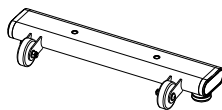

**Front stabilizer X1**  
**NO. 81**

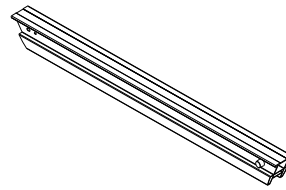

**Aluminum Rail X1**  
**NO. 110**

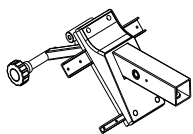

**Rail bracket set X1**  
**NO. 93**

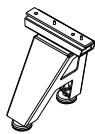

**NO. 74**  
**Rear Bracket For**  
**Aluminum Rail X1**

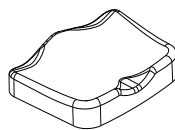

**Seat Assembly X1**  
**NO. 86**

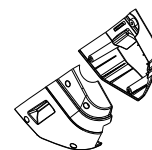

**Cover set for**  
**main shrouds X1**  
**NO. 114/115**



**Rear Cover For**  
**Aluminum Rail X1**  
**NO. 75**

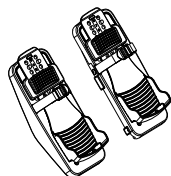

**Pedal set X1**  
**NO. 103/104**



**M5X12L Screw X4**  
**NO. 58**



**M4X20L Screw X2**  
**NO. 57**



**M6\*10L Screw X8**  
**NO. 50**



**M6X20L Screw X1**  
**NO. 51**



**M10X40L Screw X1**  
**NO. 53**



**M10X50L Screw X1**  
**NO. 54**

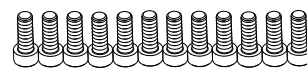

**M10X20L Screw X12**  
**NO. 52**

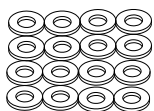

**M10X21X2.0T**  
**Flat Washer X16**  
**NO. 56**



**M6X16X1.5T**  
**Flat Washer X8**  
**NO. 55**

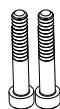

**M10X60L Screw X2**  
**NO. 62**



**SPACER RING X2**  
**NO. 60**



**RING X2**  
**NO. 59**



**Rubber Pad X2**  
**NO. 61**

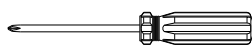

**Tool X1**



**M5X113L Tool X1**



**M8X180L Tool X1**

# ASSEMBLY INSTRUCTIONS

1

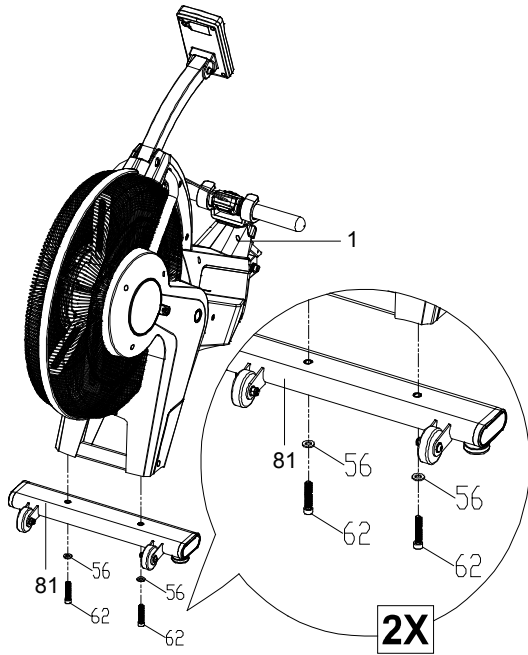

## STEP 1

Attach the **Front Stabilizer (No. 81)** to the **Frame (No. 1)** using 2 **Screws (No. 62)** and 2 **Washers**.

2

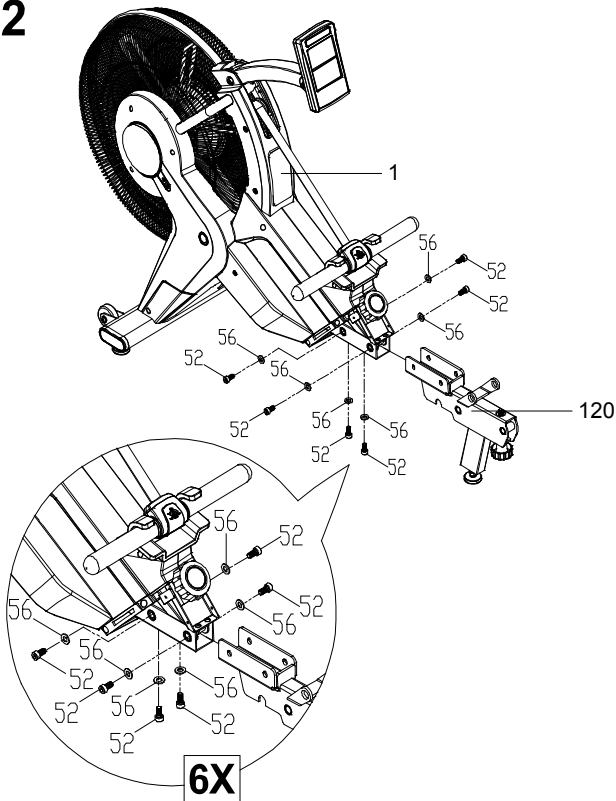

## STEP 2

Attach the **Middle Fixed Set (No. 120)** to the **Frame (No. 1)** using 6 **Screws (No. 52)** and 6 **Washers (No. 56)**.

**3****STEP 3**

Attach the **Left Case (No. 114)** to the **Middle Fixed Set (No. 120)** using 2 **Screws (No. 58)** and 2 **Screws (No. 57)**.

Attach the **Right Case (No. 115)** to the **Middle Fixed Set (No. 120)** using 2 **Screws (No. 58)**.

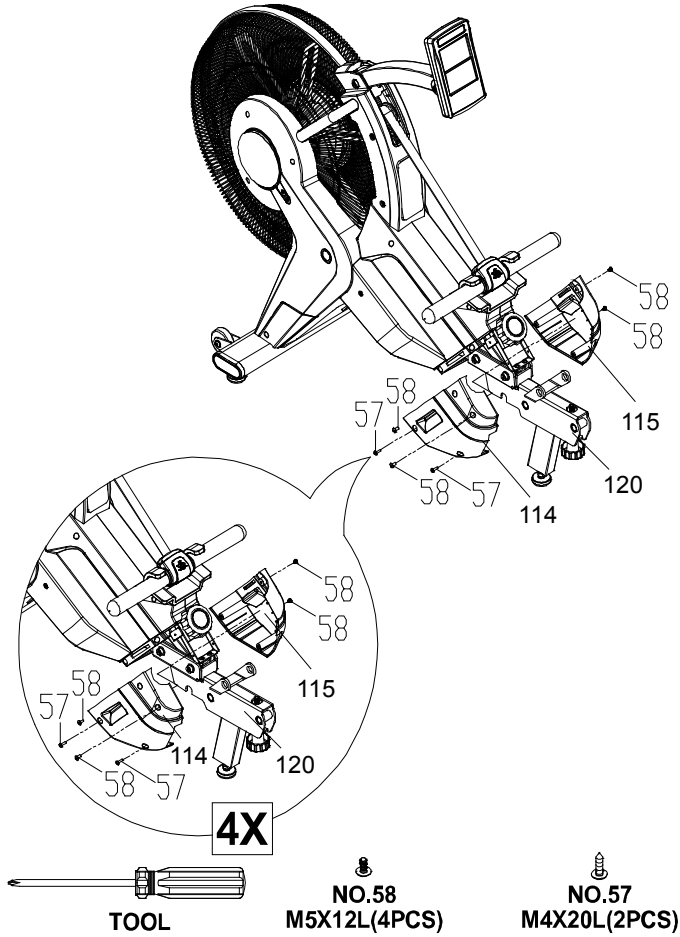
**4****STEP 4**

Attach the **Rail Bracket Set (No. 93)** to the **Middle Fixed Set (No. 120)** using 2 **Screws (No. 52)**, 2 **Washers (No. 56)**, 2 **Rings (No. 59)** and 2 **Spacer Rings (No. 60)**.

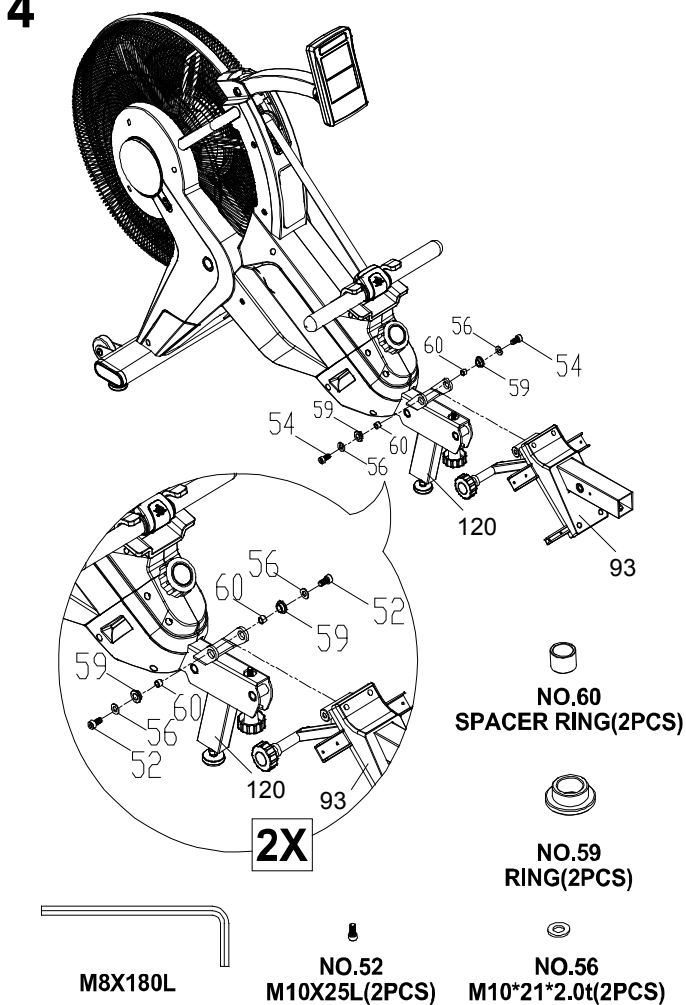

5

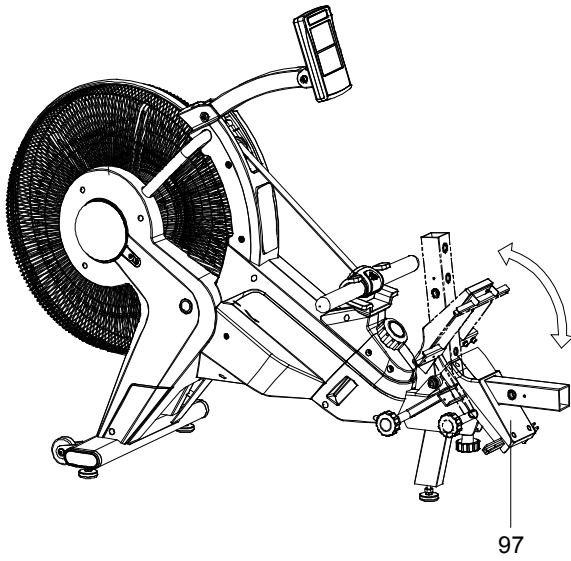

STEP 5

Check the **Rail Bracket Cover (No. 97)** can be raised and lowered.

6

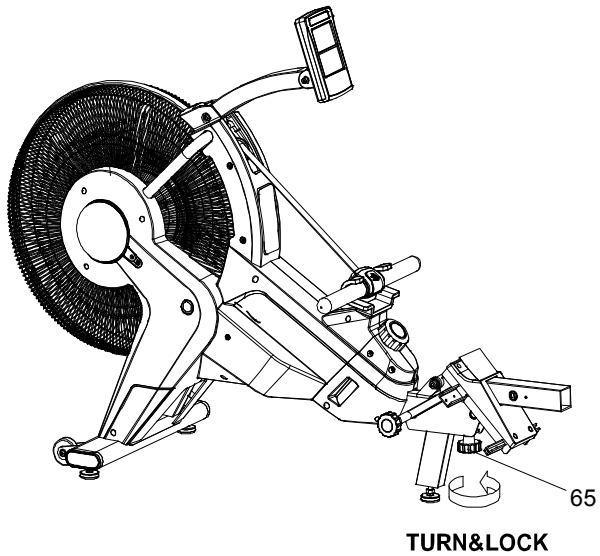

STEP 6

Turn **Knob (No. 65)** to tighten.

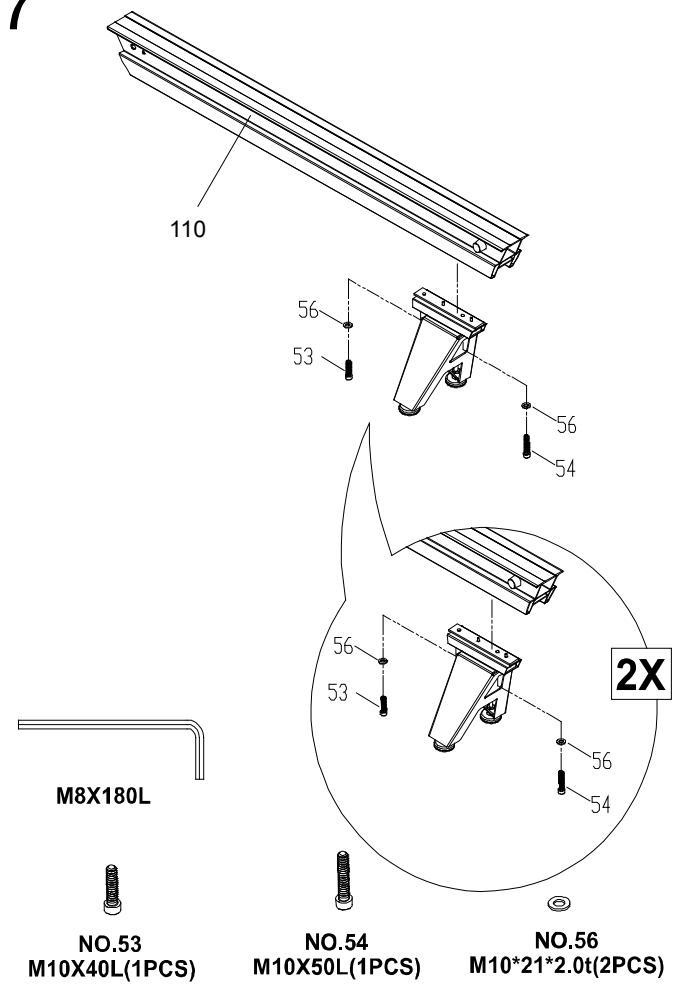
**7****STEP 7**

Attach the **Rear Bracket** to the **Rail (No. 110)** using **1 Screw (No. 53)**, **1 Screw (No. 54)** and **2 Washers (No. 56)**.

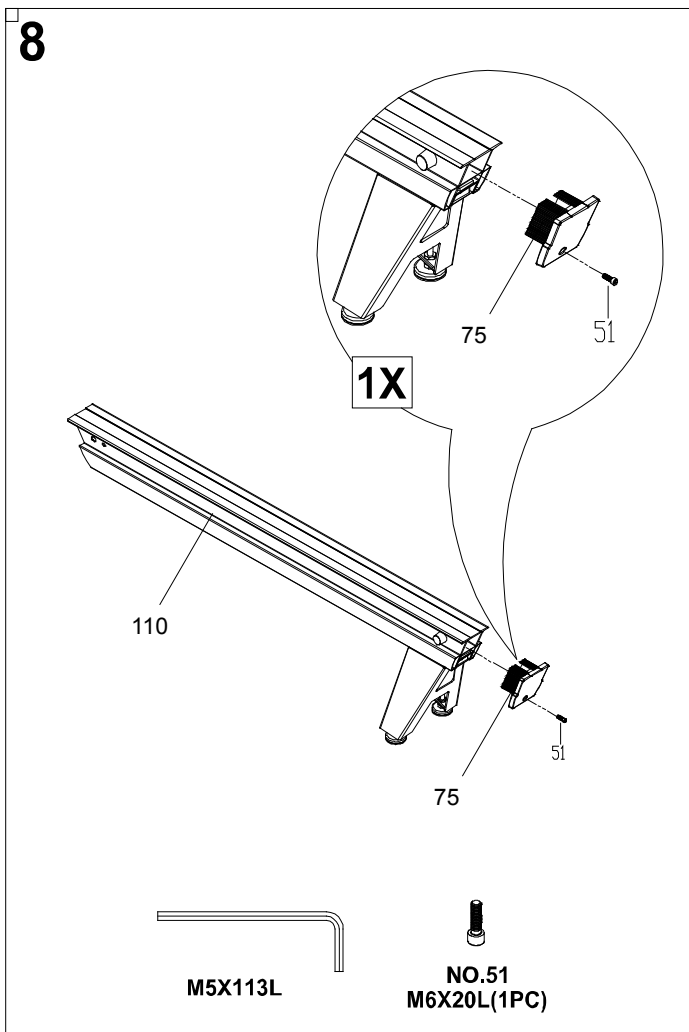
**8****STEP 8**

Attach the **Rail Rear Cover (No. 75)** to the **Rail (No. 110)** using **Screw (No. 51)**.



9

STEP 9

Slide the Seat Assembly onto the **Rail (No. 110)**.

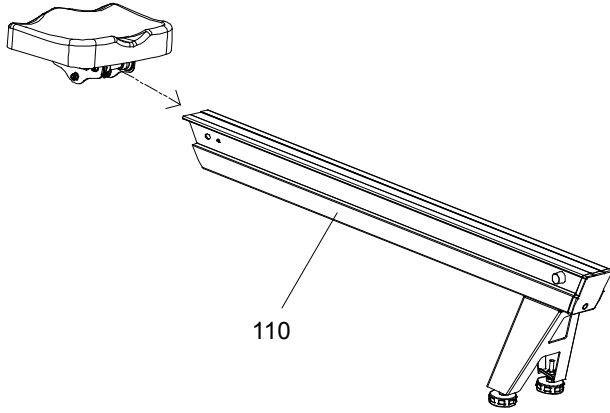

10

STEP 10

Attach the **Rail Front Cover (No. 111)** to the **Rail (No. 110)**.

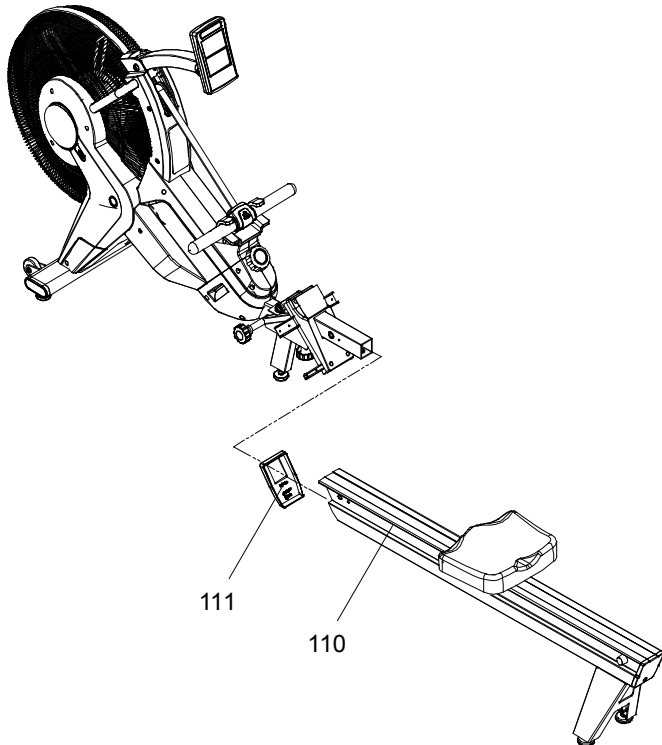

11

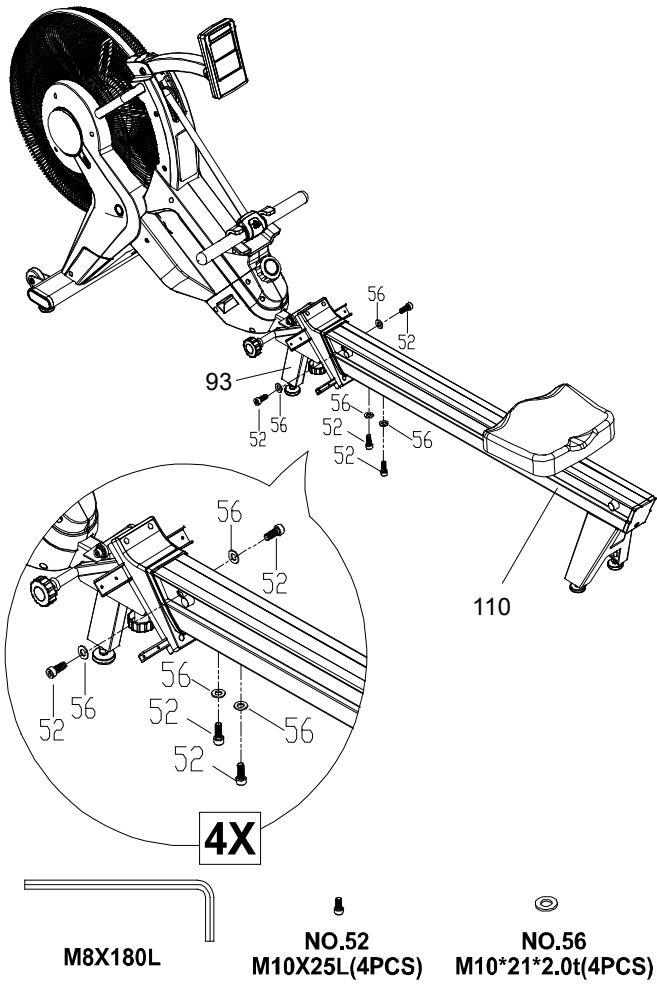

STEP 11

Attach the **Rail (No. 110)** to the **Rail Bracket Set (No. 93)** using 4 **Screws (No. 52)** and 4 **Washers (No. 56)**.

12

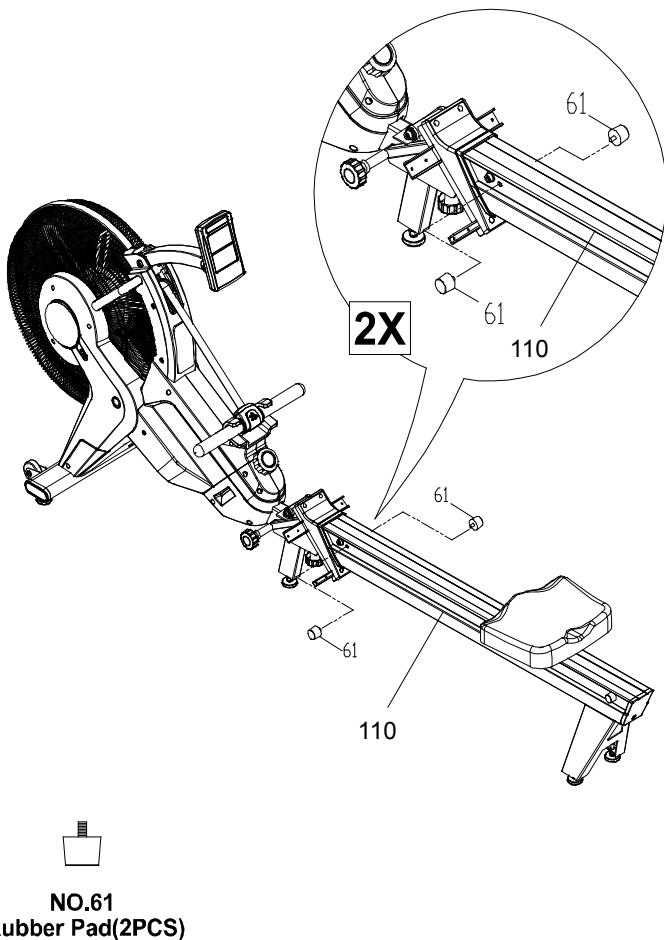

STEP 12

Insert the 2 **Rubber Pads (No. 61)** into the **Rail (No. 110)**.

13

STEP 13

Slide the left and right pedals onto the rower.

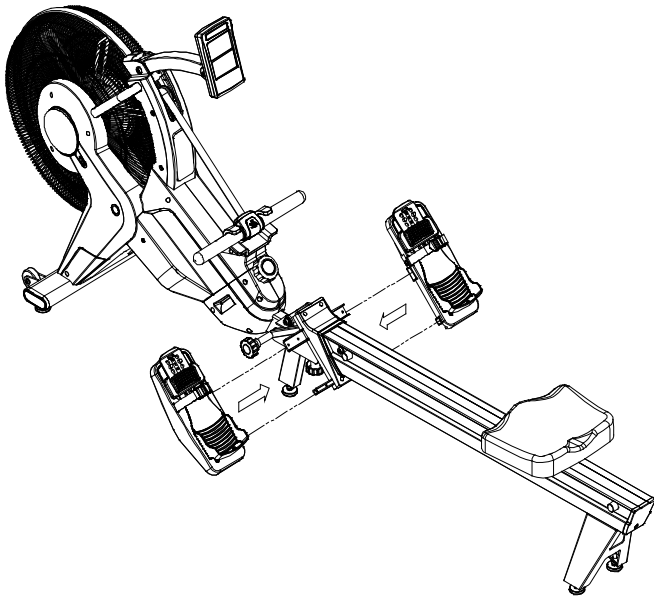

14

STEP 14

Attach the left pedal using 4 **Screws (No. 50)** and 4 **Washers (No. 55)**.

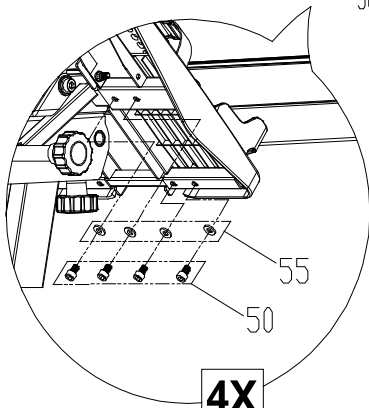
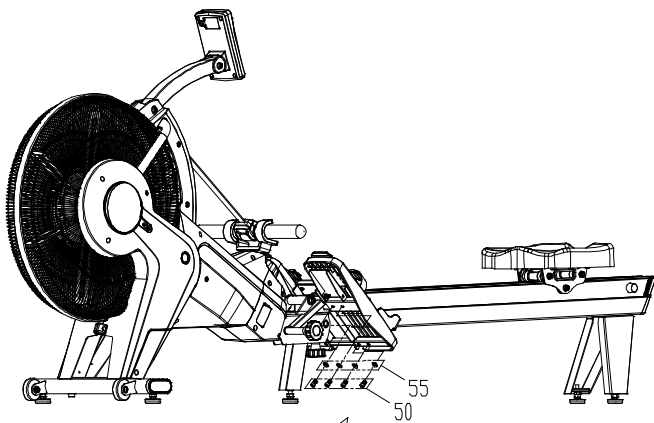

M5X113L



NO.50  
M6\*10L(4PCS)



NO.55  
M6\*16\*1.5t(4PCS)

15

STEP 15  
Attach the right pedal using 4 **Screws (No. 50)** and  
4 **Washers (No. 55)**.

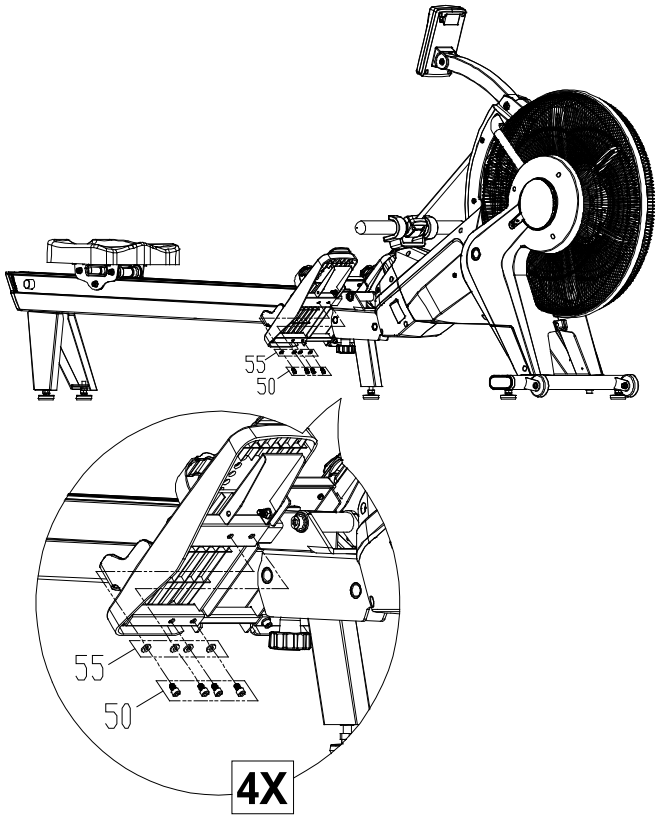

M5X113L

NO.50  
M6\*10L(4PCS)

NO.55  
M6\*16\*1.5t(4PCS)

16

STEP 16  
Assembly is complete!

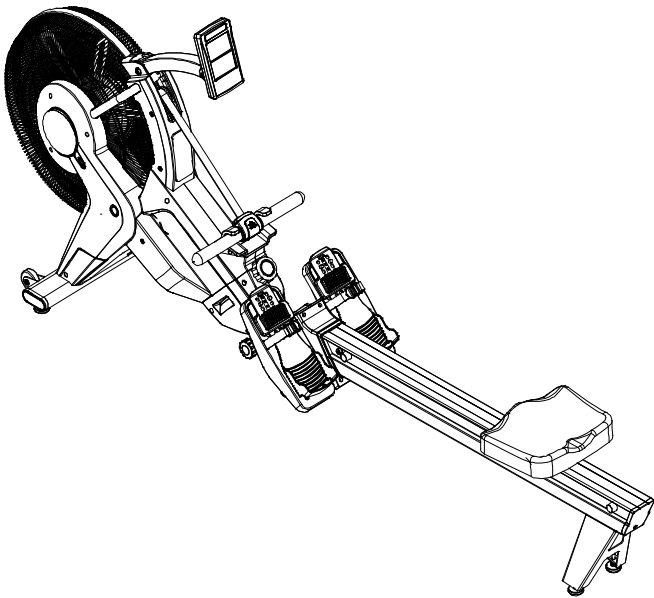

# OVERVIEW

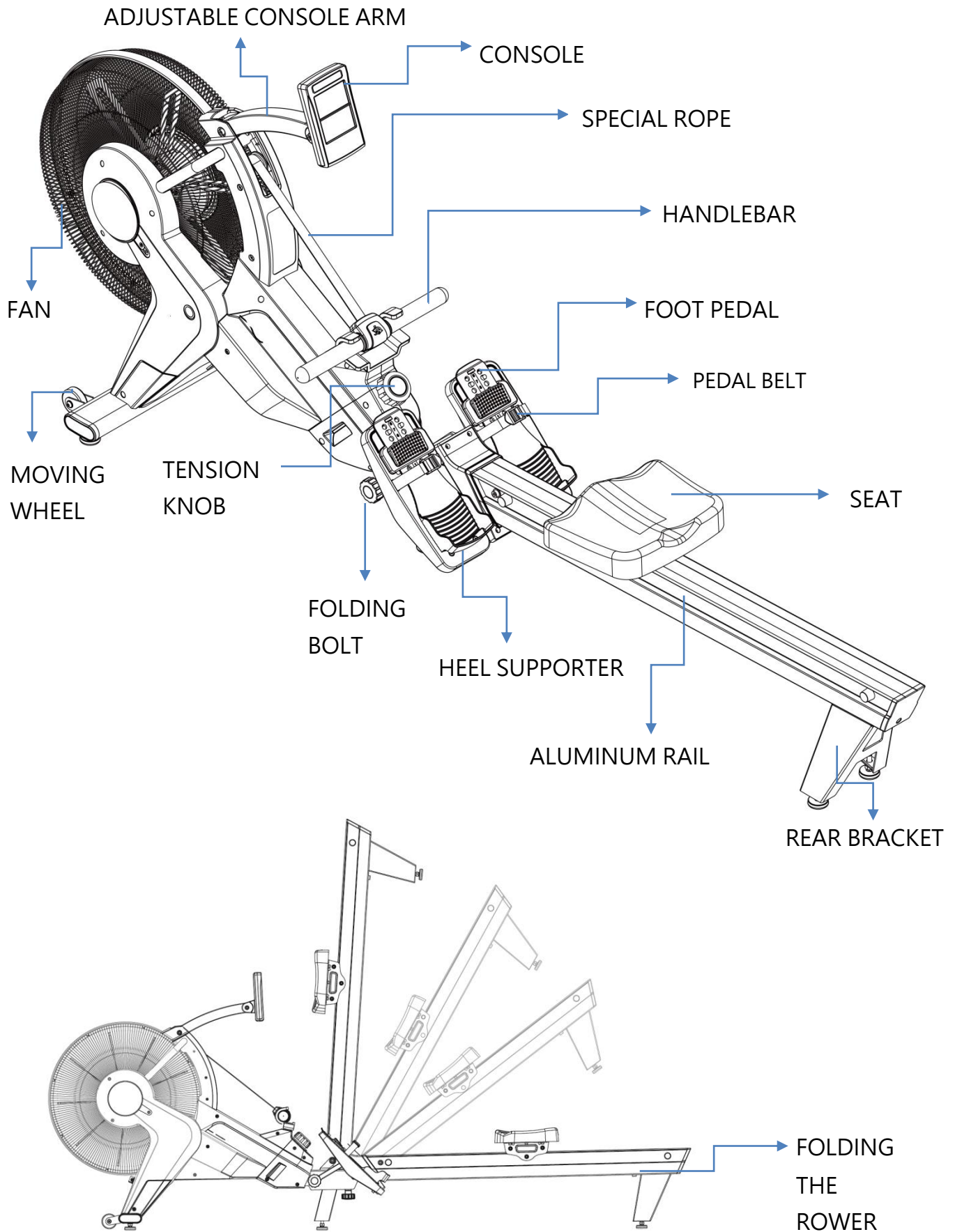

# FOLDING INSTRUCTION

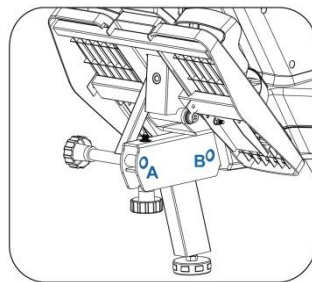
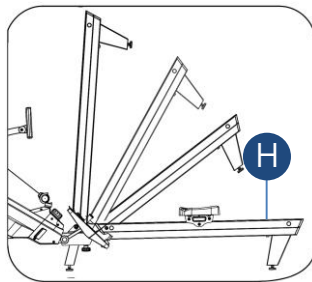
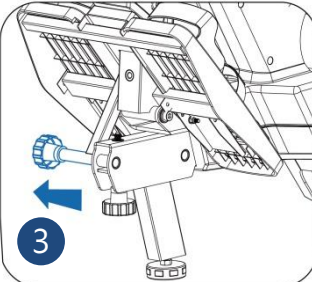
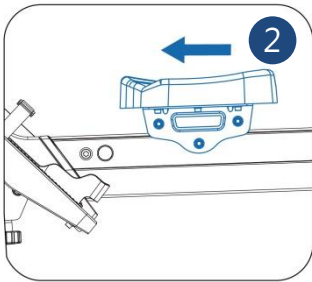
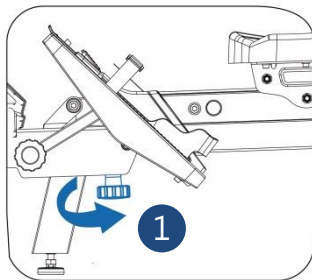
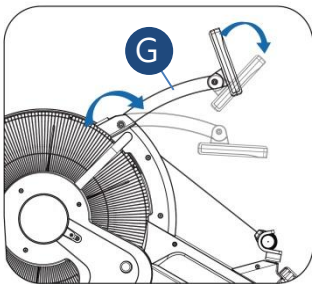
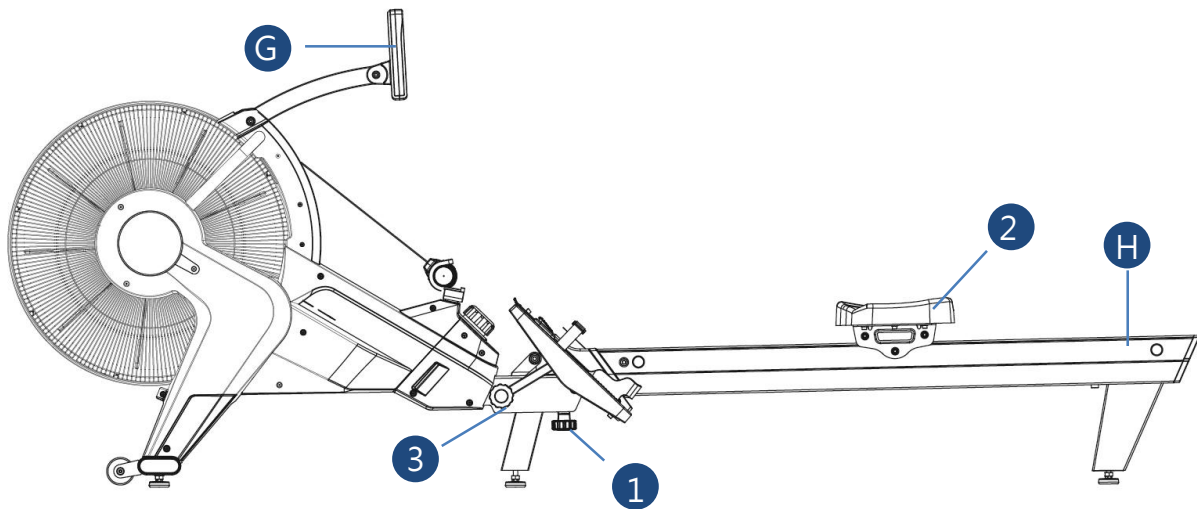

- **STEP 1**  
Press down console and adjustable arm (G), and loosen the knob (1)
- **STEP 2**  
Then move the seat to the front rail.
- **STEP 3**  
Pull the bolt (3), and lift up rail (H)
- When you use the machine, please pull the bolt (3), put down rail (H), and then lock the knob (1).

## CAUTION!

1. Before and after exercise, make sure knob is locked completely at Position A or B. (When lay down the rail flatly, pull X point up, and then the knob will be well-locked)

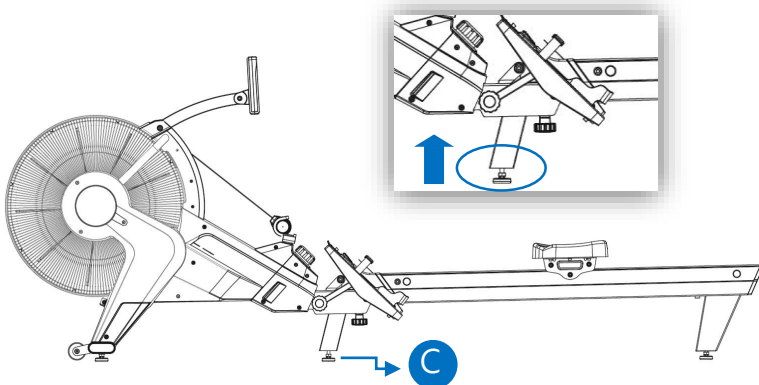
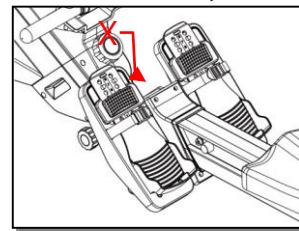

2. When you use machine, lay rail (H) flat first. Then, adjust the feet (C) up for 3mm to prevent machine shaking during exercise.

# USING THE ROWING MACHINE

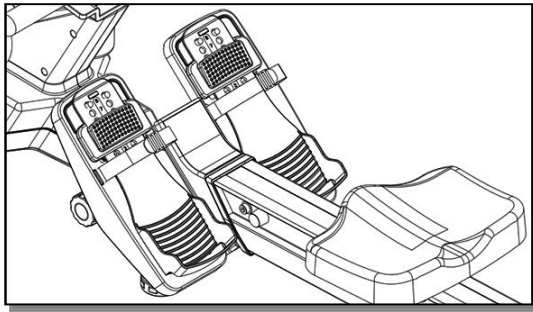

- **READY YOUR BODY**

Sit down on the rowing seat and place your feet under the adjustable straps. Pull the straps tight to secure your feet to the pedals. Adjust the pedals if needed. Lean your body slightly forward with your back straight and extend your arms to grab the handle.

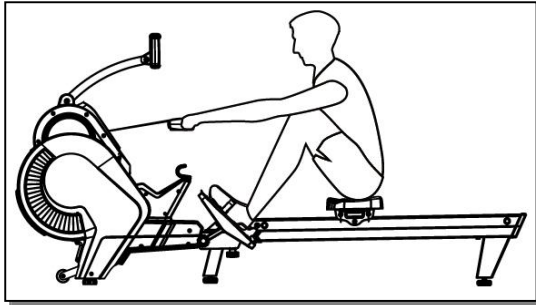

- **STEP 1**

Use your legs to push your body back. Keep your arms straight and grip the handle firmly.

- **STEP 2**

Begin to pull on the handle bar while bending your elbows. As you pull with your arms, lean back slightly.

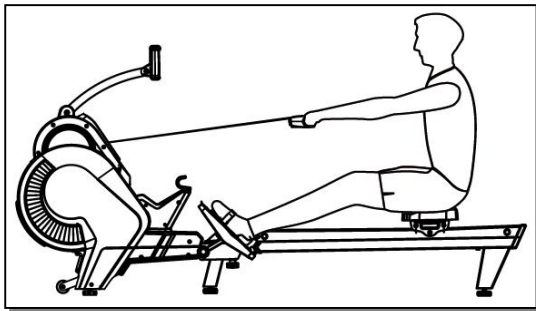

- **STEP 3**

Pull the bar to the area between your navel and lower chest. Keep your elbows close to your body.

- **RECOVER**

To return to the starting position, extend your arms first. Lean forward slightly while maintaining an upright posture and tight core. Bend your knees to slide the rowing seat back into the starting position.

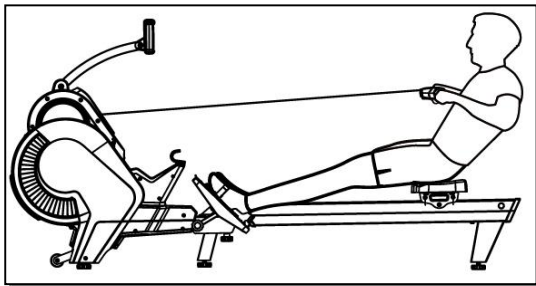

### CAUTION !

1. When returning to the starting position, make sure to extend your arms first before bending your knees.
2. Practice is encouraged since it might take some time until your rowing form feels smooth.
3. During exercise, you should feel your hamstrings, gluteus, dorsal, and biceps muscles being used.
4. When using rowing, please make sure the rope is straight and not twisted.

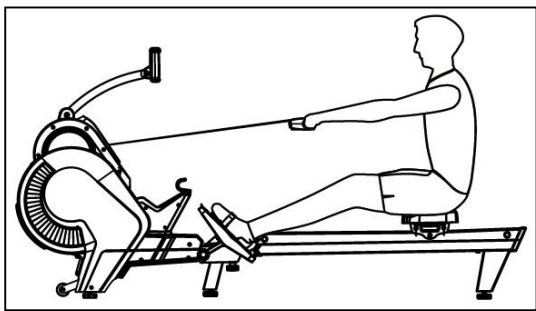

# CONSOLE OVERVIEW





# CONSOLE OVERVIEW

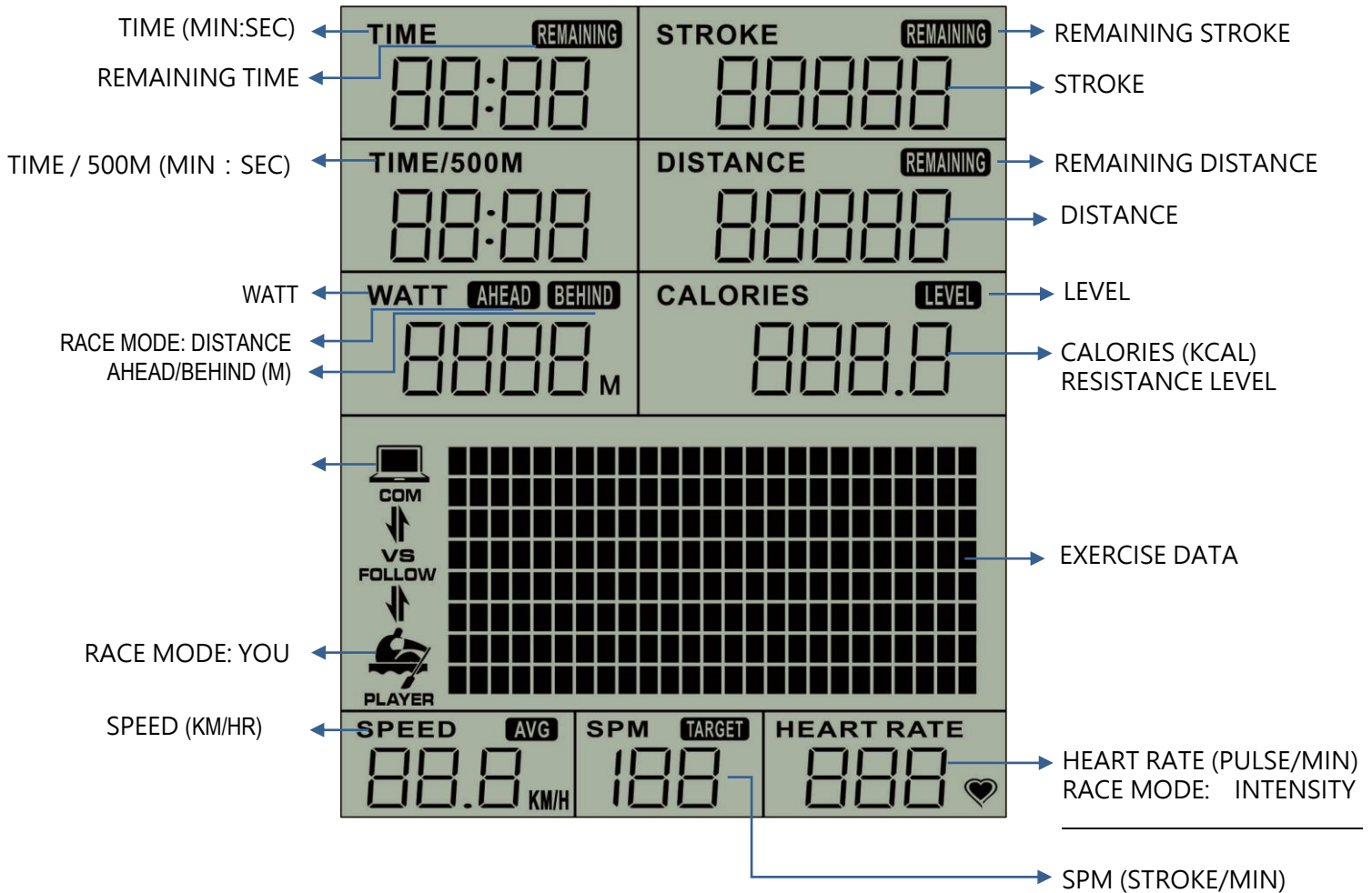

RACE MODE: COMPUTER

# CONSOLE OPERATING INSTRUCTIONS

- **POWER**

Use 2 batteries AA-size (UM-3) for console power supply.

- **TURN ON CONSOLE**



Press any console button to turn on console.

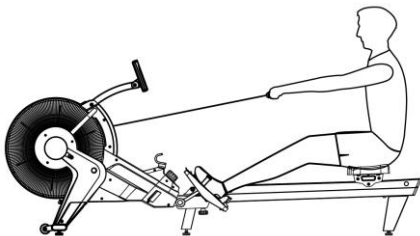

Or, start exercise to turn on console.



Then, the machine will go into 「Manual Mode.」

- **SLEEP STATE**

It will go into SLEEP MODE (power-saving) automatically if no input or exercise within 4 minutes.

- **3 BUILT-IN EXERCISE MODES**

Press **MODE**. You can select preset modes for your exercise. You can adjust the setting at each mode. The three built-in modes are:



Manual Mode



Training Mode



Race Mode

- **BUILT-IN HEART-RATE RECEIVER**

This rower has built-in wireless heart-rate receiver. Wireless chest strap is not included.

# CONSOLE OPERATING INSTRUCTIONS

## ● EXERCISE MODE

### MODE & ICON



### MANUAL MODE

After you start exercise, console will detect your data.

### EXERCISE

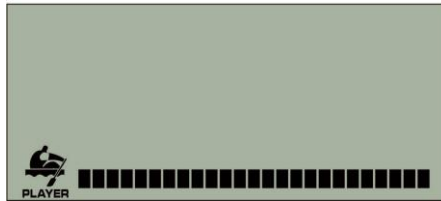

Example 1

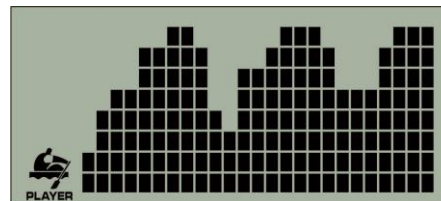

Example 2

Data display screen will show STROKE-SPEED chart, according to speed of your stroke.

### ADJUSTABLE SETTING (range ; increment ; preset)

STROKE  
(0~99999 ; ±10 ; 0)

TIME  
(0:00~99:59 ; ±1:00 ; 0:00)

DISTANCE  
(100~99900 ; ±100 ; 500M)

NOTE : You select one setting for your exercise.

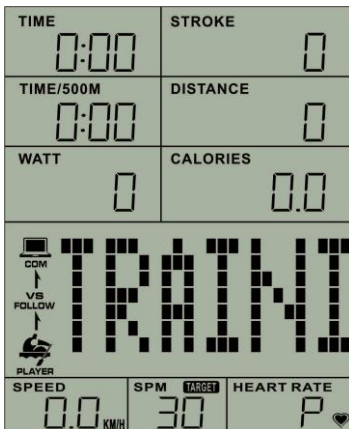

### TRAINING MODE

You can follow the display screen guide to row. The purpose of this mode is to

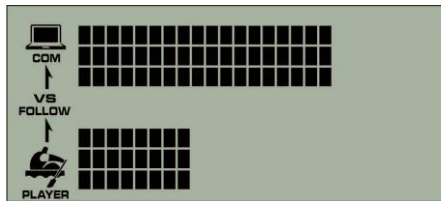

Training Example 1

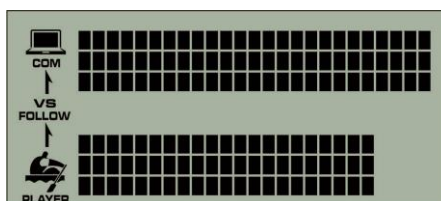

Training Example 2

Upper display screen will show the computer rowing guide.

SPM  
(20~80 ; ±1 ; 30 SPM)

STROKE  
(0~99999 ; ±10 ; 0)

TIME  
(0:00~99:59 ; ±1:00 ; 0:00)

train your rowing stability. Lower will show your exercise. You can check your exercise to meet training target or not.

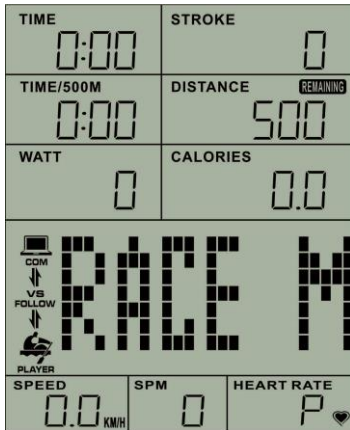

RACE MODE

Race with machine.

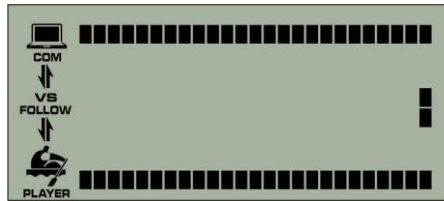

Race Example 1

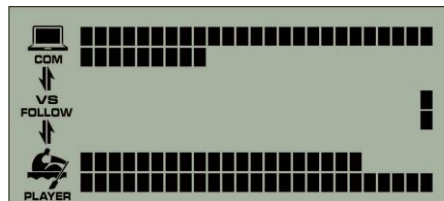

Race Example 2

DISTANCE  
(100~99900 ; ±100 ; 500M)

Competition  
(L1~L5 ; ±1 ; L3)  
[L1 is low speed; L5 is the high speed.]

Upper display screen will be machine distance, and the lower will be your distance. Right side of screen will be the end. Winner is the first to the end point.



After Competition, WATT display screen will show your ahead / behind distance.

# ● FUNCTIONS

## ➤ EXERCISE MODE

You may press **MODE** to select modes.



Console will show as

「 MANUAL MODE 」 → 「 TRAINING MODE 」 → 「 RACE MODE 」 → 「 MANUAL MODE 」 → ...



Hold **START/STOP** for 3 sec, console will clean all exercise data and back to MANUAL MODE.

## ➤ RESISTANCE LEVEL SETTING ( OPTION FUNCTION )

- ✧ Before your program, press **▲UP** / **▼DOWN** to adjust your level. Please make the 「 LEVEL 」 adjustment same as the machine resistance knob. Then, press **ENTER** to confirm.
- ✧ During exercise (at START STATE), press **▲UP** / **▼DOWN** to adjust console resistance level.



(LEVEL: 1-12)



(LEVEL UP / DOWN)

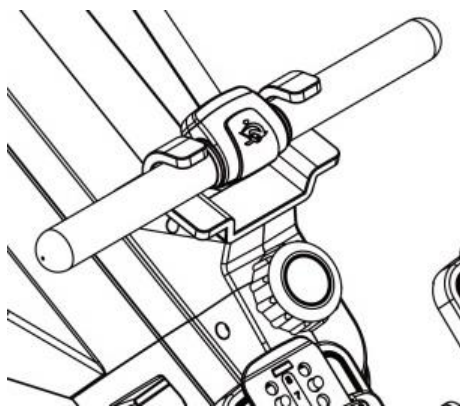

- ✧ After adjusting the resistance using the console and machine resistance knob, console can calculate more accurate data for SPEED, WATT, CALORIES...and so on.

➤ **TRAINING TARGET SETTING (OPTIONAL)**

- ✧ After selecting training program, press **ENTER** to program target setting. The setting you select will flicker.
- ✧ You may press **UP** or **DOWN** to adjust your setting. Then, press **ENTER** to confirm.

**NOTE:** All adjustment is for one time. After console re-starting or selecting other mode, all data will be back to preset.

➤ **START / PAUSE / RESUME / END PROGRAM**

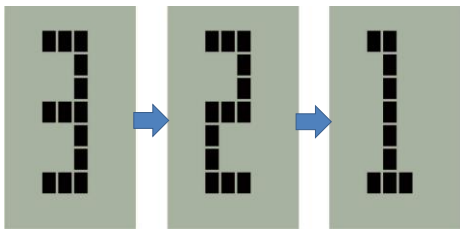

After selecting mode and confirm target setting, please press **START/STOP**. Console will count down 「3→2→1」 and start your program (console will be at START STATE). You may control the program as below:

- ✧ During the program, press **START/STOP** to pause program (console will be at PAUSE STATE). Console will stop counting, and show 「PAUSE」.

**NOTE :**

1. In MANUAL MODE, at PAUSE STATE, 「 SPEED 」 will show your last stroke SPEED and AVG SPEED.
  2. At TRAINING MODE, at PAUSE STATE, 「 SPM 」 will show TARGET SPM and AVG SPM; 「 SPEED 」 will show your last stroke SPEED and AVG SPEED.
  3. At RACE MODE, at PAUSE STATE, 「 WATT 」 will show WATT and your AHEAD / BEHIND DISTANCE; 「 SPEED 」 will show your last stroke SPEED and AVG SPEED. 「 HEART RATE 」 will show HEART RATE and Competition INTENSITY.
  4. If selecting machine resistance setting, at PAUSE STATE, 「 CALORIES 」 will show CALORIES and LEVEL.
- ✧ During program or PAUSE STATE, you may press **START / STOP** to end the program. Console will be STOP STATE.
  - ✧ After finishing program, console will stop counting with a beep sound. Console will be STOP STATE.
  - ✧ Display screen will show all your exercise data until console into SLEEP STATE.

# TROUBLE SHOOTING

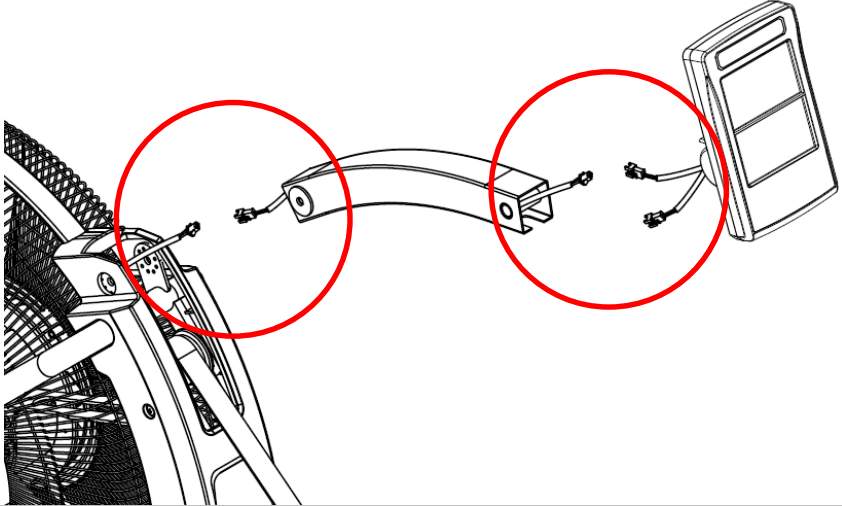
ISSUE	CAUSE	INSPECTION and ELIMINATING
No Power On (can't turn on)	Battery Power NOT enough	Replace two new batteries AA-size (UM-3), and make sure positive (+) and negative (-) pole at the right position.
Display Off	Battery Power NOT enough	Replace two new batteries AA-size (UM-3), and make sure positive (+) & negative (-) pole at the right position.
Data does not change (during the exercise)	Console is showing 「 PAUSE 」 or 「 STOP 」	When the screen is showing 「 PAUSE 」 or 「 STOP 」, console is at pause or stop state. You may press START to start, and TIME display screen will continue counting. Console will continue to work.
	Speed sensor NOT connected completely	When the screen is showing 「 TIME 」, console is at start state. And, SPEED & SPM display data will show "0." This means console detect no exercise. Please check and connect the console wire completely. 
Suddenly no display	Console NO input for long time (into SLEEP MODE)	Console is with power-saving function. It will go into SLEEP MODE automatically, if after 4 minutes of no input or exercise. You may press any button or pull the handlebar more than 30cm to wake up console.

# EXPLODED DIAGRAM

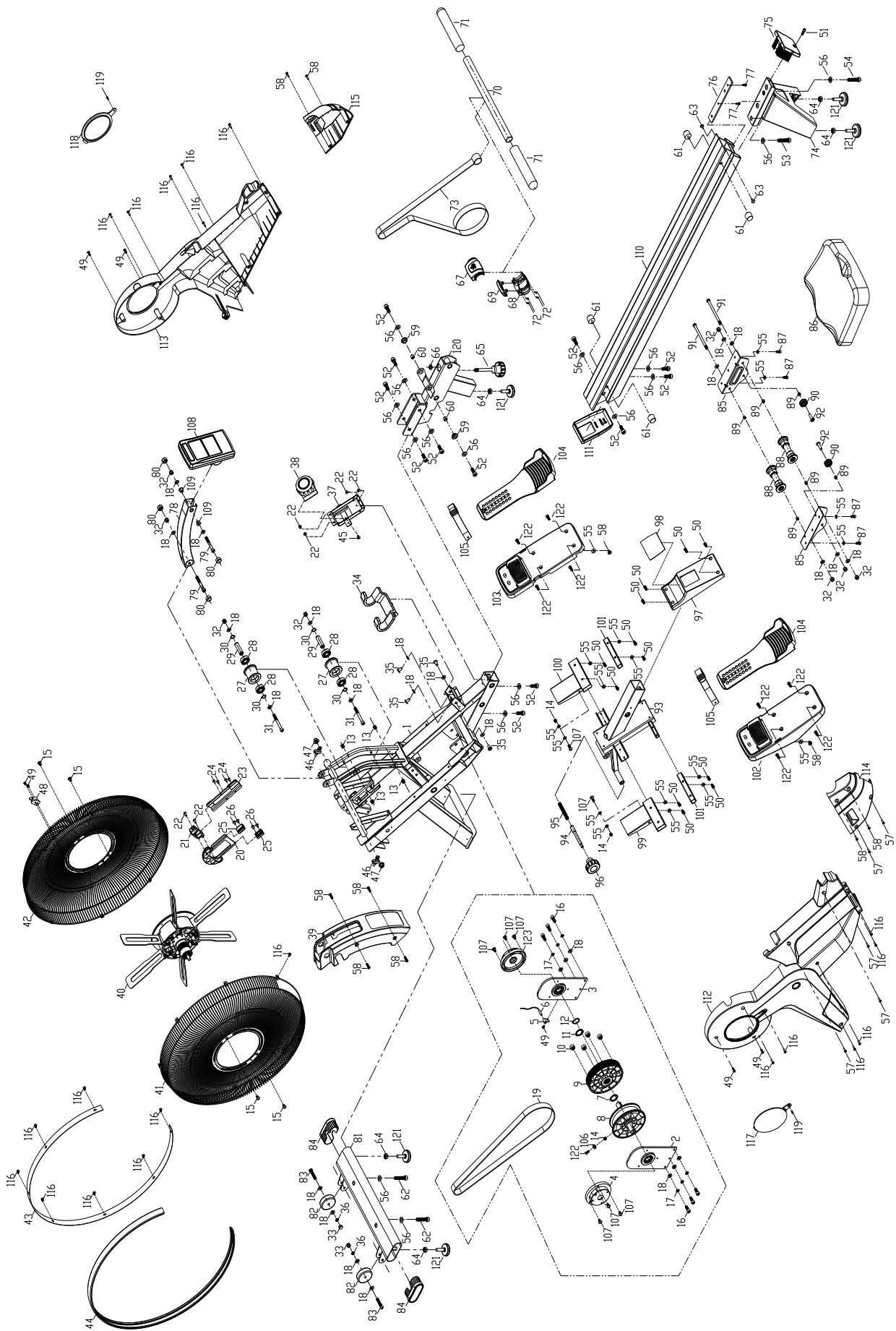



# PARTS LIST

PART NO.	Name	Qty	PART NO.	Name	Qty
1	FRAME	1	63	WASHER 32*25.2*T2.0	1
2	BELT AXLE BRACKET	2	64	NUT M10*1.5*8t	5
3	SPEED SENSOR FIXED PLATE	1	65	KNOB	1
4	LEFT SCROLL SPRING SET	1	66	NUT M10*1.5*6t	1
5	SPEED SENSOR BRACKET	1	67	HANDLEBAR COVER - UPPER	1
6	SENSOR - DOWN	1	68	HANDLEBAR COVER - DOWN	1
7	CURVE WASHER 25.5*34*2.0T	1	69	HANDLEBAR ANTI-COLLISION COVER	1
8	ROPE WHEEL SET	1	70	ALUMINUM PIPE	1
9	BELT WHEEL SET	1	71	HANDLEBAR COVER	2
10	ROUND MAGNET	4	72	SCREW M3*10L	4
11	HANDLEBAR SPACER RING	1	73	SPECIAL ROPE	1
12	C25 CLIP	1	74	REAR STABILIZER	1
13	SCREW M5*8L	2	75	RAIL REAR COVER	1
14	NYLOCK NUT M6	3	76	RAIL PLATE	1
15	SCREW M5*12L	4	77	SCREW M8*16L	2
16	SCREW M8*20L	6	78	CONSOLE ARM	1
17	SPRING WASHER M8	6	79	SCREW M8*65L	2
18	WASHER M8*16*2.0	27	80	NUT 13MM	4
19	BELT	1	81	FRONT STABILIZER	1
20	MAGNET FIXED PLATE SET	1	82	MOVING WHEEL	2
21	MAGNET BRACKET	1	83	SCREW M8*45L	2
22	SCREW M5*16L	4	84	OVAL PIPE	2
23	GUIDE PLATE	1	85	SEAT FIXED PLATE	2
24	SCREW M5*8L	4	86	SEAT	1
25	MAGNETIC DRAG RAIL	2	87	SCREW M6*16L	4
26	SCREW M5*10L	4	88	UPPER PULLEY SET	2
27	GUIDE WHEEL	2	89	DOWN PULLEY SPACER RING	6
28	BEARING TPI6202	4	90	DOWN PULLEY	2
29	GUIDE SHAFT	2	91	SCREW M8*122	2
30	C15 CLIP	4	92	SCREW M8*25L	2
31	SCREW M8*75L	2	93	RAIL BRACKET SET	1
32	NYLOCK NUT M8	8	94	BOLT	1
33	CAP NUT M8	2	95	SPRING	1
34	HANDLEBAR FIXED SEAT	1	96	KNOB	1
35	SCREW M8*15L	4	97	RAIL BRACKET MIDDLE COVER	1
36	SPRING WASHER M8	2	98	STICKER	1
37	TRIMMING FIXED SET	1	99	LEFT PEDAL PIPE	1
38	TRIMMING KNOB	1	100	RIGHT PEDAL PIPE	1
39	ROPE GATE FRAME	1	101	REAR PEDAL PIPE	2
40	FAN COVER	1	102	LEFT PEDAL BRACKET	1

# PARTS LIST

PART NO.	Name	Qty	PART NO.	Name	Qty
41	FAN LEFT COVER	1	103	RIGHT PEDAL BRACKET	1
42	FAN RIGHT COVER	1	104	HEEL SUPPORTER	2
43	FAN COVER TRIM	1	105	PEDAL BELT	2
44	TRIM PLATE	1	106	WASHER M6*20*1.5T	1
45	SCREW M4*12L	1	107	SCREW M6*16L	12
46	CHAIN TENSIONER	2	108	CONSOLE	1
47	WH NUT M10*1.5X14X8	2	109	PLASTIC PLUG	2
48	ROPE BRACKET	1	110	ALUMINUM RAIL	1
49	SCREW M4*8L	3	111	RAIL FRONT COVER	1
50	SCREW M6*10L	12	112	LEFT MAIN CASE	1
51	SCREW M6*20L	1	113	RIGHT MAIN CASE	1
52	SCREW M10*25L	12	114	LEFT CASE	1
53	SCREW M10*40L	1	115	RIGHT CASE	1
54	SCREW M10*50L	1	116	SCREW M4*16L	24
55	WASHER M6*16*1.5	18	117	LEFT MAIN COVER	1
56	WASHER M10*21*2.0	16	118	RIGHT MAIN COVER	1
57	SCREW M4*20L	5	119	SCREW M4*12	2
58	SCREW M5*12L	8	120	MIDDLE FIXED SET	1
59	RING	2	121	ADJUSTABLE FOOT	5
60	SPACER RING	2	122	SCREW M6*20L	9
61	RUBBER PAD	4	123	RIGHT SCROLL SPRING SET	1
62	SCREW M10*60L	2			

## Ordering Replacement Parts (U.S. and Canadian Customers only)

Please provide the following information in order for us to accurately identify the part(s) needed:

- ✓ The model number (found on cover of manual)
- ✓ The product name (found on cover of manual)
- ✓ The part number found on the “EXPLODED DIAGRAM” and “PARTS LIST”

