

Assembly

1 Attaching the legs

- Attach the leg support (D) to the chair legs (B1 and B2) by using the 1/4 in. x 20 mm bolts (AA).
- Guide the bolts (AA) through the holes in the leg support (D), into the pre-drilled holes in the chair legs (B1 and B2).
- Hand tighten only.

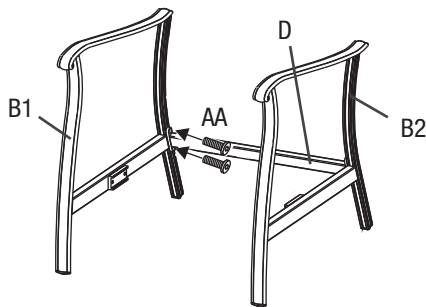

2 Attaching the support bar

- Attach the support bar to the chair legs by using the 1/4 in. x 20 mm bolts (BB) and the $\text{\O}6.5 \times 1.6$ mm spring washers (GG).
- Guide these bolts (BB) through the holes in the support bar (C), into the pre-drilled holes in the chair legs (B1 and B2).
- Hand tighten only. Do not over tighten. Over tightening may strip bolts.

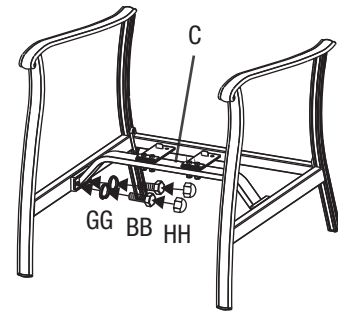

3 Setting the chair frame

- Set the chair frame (A) on the rocker assembly with the front of the seat facing you and the arrows on the "U" bar pointing towards you. This is very important for a safe, balanced rocking motion.
- If the chair frame (A) has been properly positioned on the rocker assembly, all arrows on the "U" bar and rocker assembly will be pointing in the same direction.
- Adjust alignment of the holes of support bar (C) and "U" bar.
- Insert a metal plate (EE).
- Guide the 5/16 in. x 40 mm bolts (CC) through the holes of metal plate (EE), "U" bar, and support bar (C) from the top side of metal plate (EE).
- Add a $\text{\O}8.0 \times 2.3$ mm spring washer (DD) and a nut (FF) to each bolt (CC).
- Hand tighten only. Repeat the same procedure on the other side.
- Tighten all nuts and bolts with the hex wrenches (KK and LL) provided and cover all bolts (AA, BB and CC) with bolt covers (HH and II).

