



YOW sku #690 132/694 431

Model# D11200-7PC-B

USE AND CARE GUIDE

MIDDLETOWN 7PC DINING SET

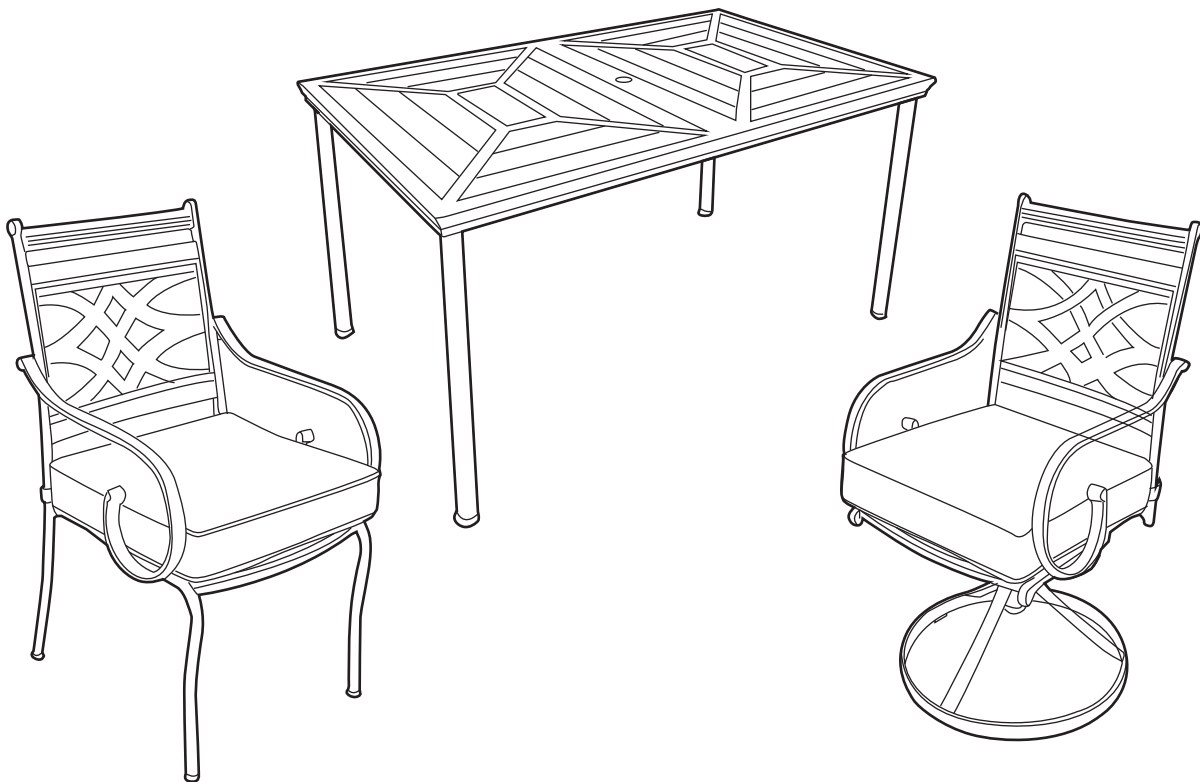

Questions, problems, missing parts? Before returning to the store,

call Hampton Bay Customer Service

8 a.m. - 7 p.m., EST, Monday-Friday

9 a.m. - 6 p.m., EST, Saturday

1-855-HD-HAMPTON

HAMPTONBAY.COM



THANK YOU

We appreciate the trust and confidence you have placed in Hampton Bay through the purchase of this dining set. We strive to continually create quality products designed to enhance your home. Visit us online to see our full line of products available for your home improvement needs. Thank you for choosing Hampton Bay!

Table of Contents

Table of Contents	2	Assembly	7
Safety Information	2	Care and Cleaning	10
Warranty	2		
What is Covered	2		
What is Not Covered	2		
Pre-assembly	3		
Planning Assembly	3		
Tools Required	3		
Hardware Included	3		
Table Package Contents	4		
Dining Chair Package Contents	5		
Swivel Dining Chair Package Contents	6		

Safety Information

-  **WARNING:** Do not sit or stand on the table top.
-  **WARNING:** Do not place heavy items on the table top.
-  **WARNING:** An umbrella base must be used at all times. Umbrella should not be used in the event of wind, rain, hail, sleet, snow or any other inclement weather.

Warranty

THIS IS A RESIDENTIAL WARRANTY AND DOES NOT APPLY FOR COMMERCIAL USE.

2 YEAR FRAME AND FABRIC LIMITED WARRANTY

WHAT IS COVERED

We warrant the frame and fabric to be free of manufacturing defects to the original purchaser for two years.

WHAT IS NOT COVERED

It remains the customer's responsibility for freight and packaging charges to and from our service center.

This warranty does not cover commercial use, hardware, acts of nature, fire, freezing and abusive use.

In addition, purchased parts are not covered under this warranty. We reserve the right to make substitutions with similar merchandise, if the model in question is no longer in production.

For a copy of our full limited warranty, please contact our customer service team below.

Contact the Customer Service Team at 1-855-HD-HAMPTON or visit www.hamptonbay.com.

Pre-assembly

PLANNING ASSEMBLY

PLEASE READ COMPLETE INSTRUCTION MANUAL PRIOR TO ASSEMBLY!

Identify all parts packed in the carton against the parts list. Remove all protective materials and place the parts on a nonabrasive surface to avoid scratching.



NOTE: More than one person may be required to complete the assembly of this product.

HARDWARE INCLUDED



NOTE: Tools not shown to actual size.

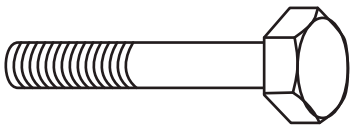

AA

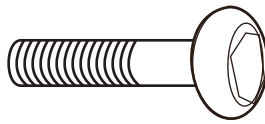

BB

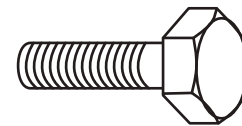

CC

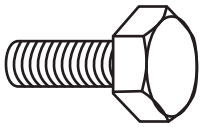

DD



EE



FF



GG



HH



II

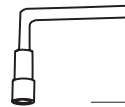

JJ

Part	Description	Quantity
AA	M6*35 Hex bolt	24
BB	M6*25 Socket hex bolt	12
CC	M6*20 Hex bolt	8
DD	M6*15 Hex bolt	12
EE	Washer	56
FF	M6 Hex bolt cap	44
GG	M6 Socket hex bolt cap	12
HH	Allen Wrench	2
II	Hex Wrench	2
JJ	Socket Wrench	1

Pre-assembly (continued)

TABLE PACKAGE CONTENTS

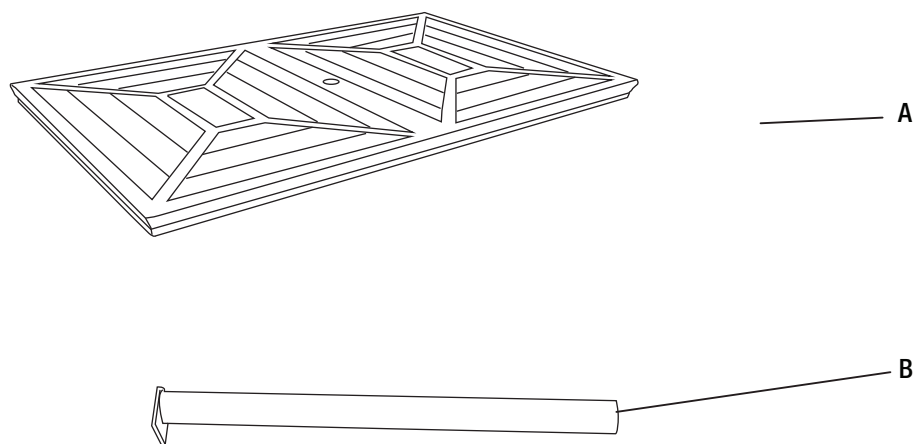

Part	Description	Quantity
A	Table top	1
B	Table leg	4

Pre-assembly (continued)

DINING CHAIR PACKAGE CONTENTS



NOTE: More than one person may be required to complete the assembly of this product.

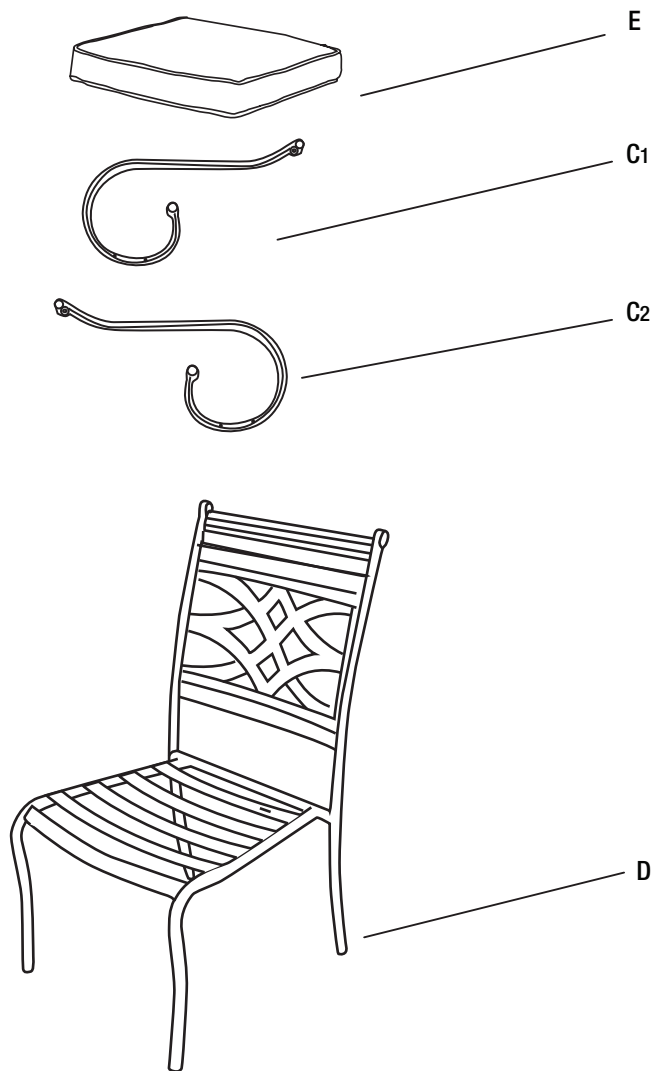

Part	Description	Quantity
D	Seat frame	4
E	Seat cushion	4
C1	Left Arm	4
C2	Right Arm	4

Pre-assembly (continued)

SWIVEL DINING CHAIR PACKAGE CONTENTS

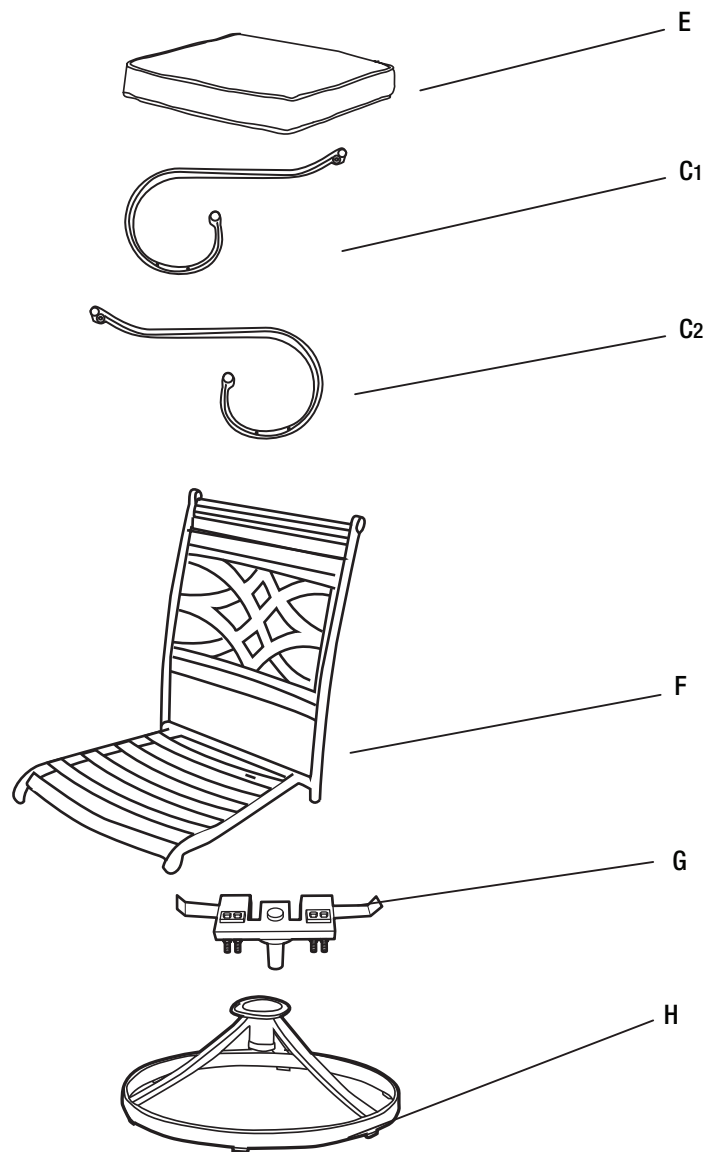

Part	Description	Quantity
E	Seat cushion	2
F	Seat frame	2
G	Stem bracket	2
H	Base	2
C1	Left Arm	2
C2	Right Arm	2

1 Attaching the table legs

- Place the table top (A) on a soft, flat non-abrasive surface.
- Attach the table legs (B) to the table top (A) using the M6*15 hex bolts (DD) and washers (EE).
- Please ensure all the bolts are assembled correctly. Tighten all the bolts (DD) with the socket wrench (JJ). Attach the hex bolts caps (FF).

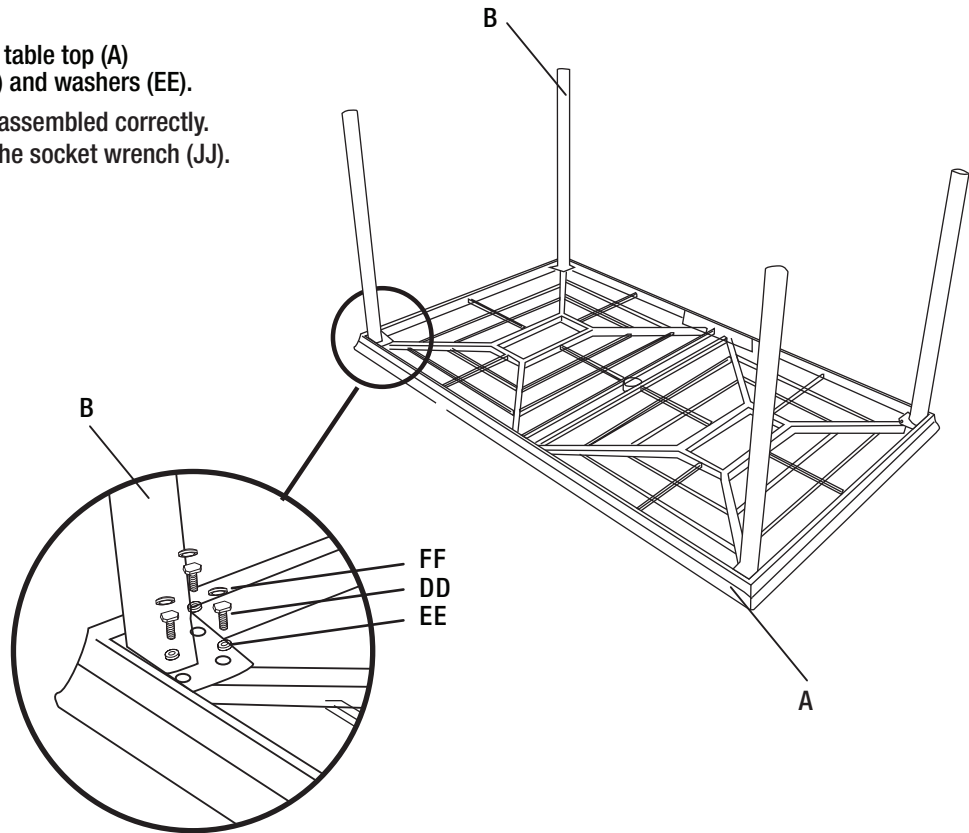

2 Positioning the table

- Turn the table over and set it down on its legs.
- The table is now ready for use.

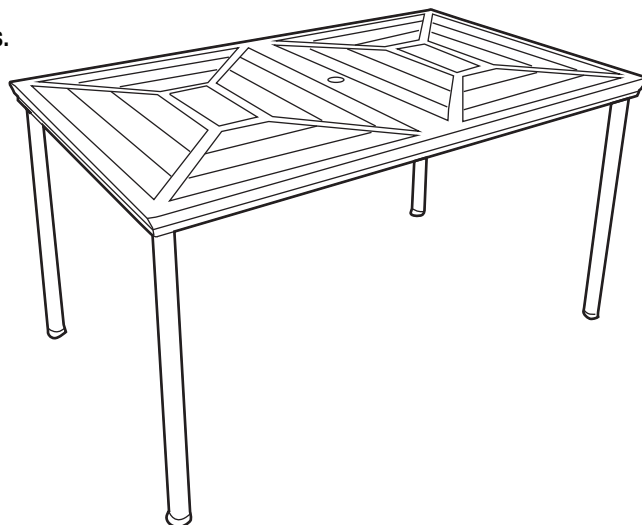

3 Attaching the arms

- Place the seat frame (D) on a soft, flat non-abrasive surface.
- Attach the front of the arms (C1) and (C2) to the seat frame (D) using washers (EE) and M6*35 hex bolts (AA). Do not fully tighten the bolts.
- Attach the back of the arms (C1) and (C2) to the seat frame (D) using a washer (EE) and M6*25 socket hex bolt (BB). Do not fully tighten the bolts.
- Ensure all bolts are aligned and assembled correctly.
- Tighten all hex bolts (AA) with the hex wrench (II). Attach the hex bolt caps (FF).
- Tighten all socket hex bolts (BB) with the allen wrench (HH). Attach the socket hex bolt caps (GG).

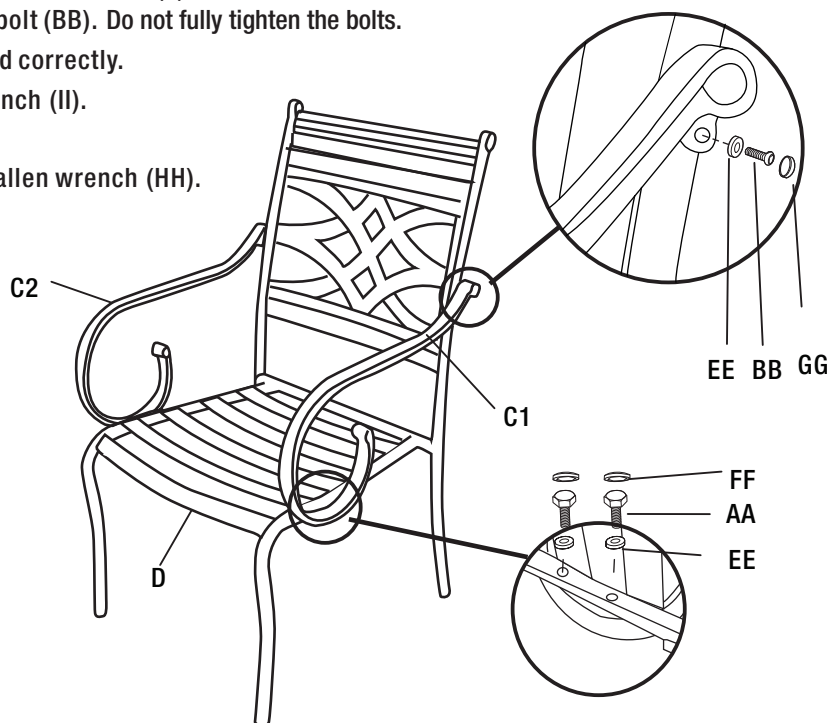

4 Adding the seat cushions

- Place the seat cushion (E) onto the chairs.

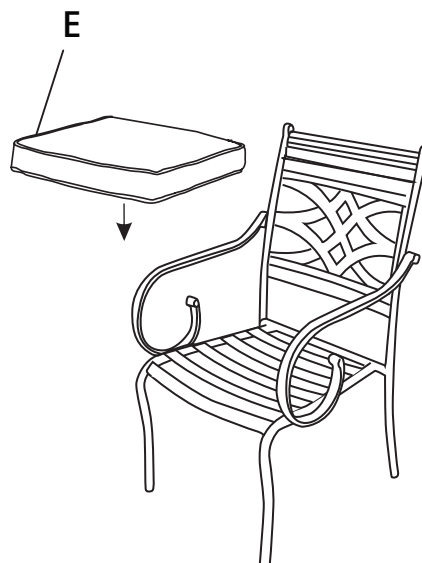

Assembly (continued)

5 Attaching the arms

- Place the seat frame (F) on a soft, flat non-abrasive surface.
- Attach the front of the arms (C1) and (C2) to the seat frame (F) using washers (EE) and hex bolts (AA). Do not fully tighten the bolts.
- Attach the back of the arms (C1) and (C2) to the seat frame (F) using a washer (EE) and socket hex bolt (BB). Do not fully tighten the bolts.
- Ensure all bolts are aligned and assembled correctly.
- Tighten all socket hex bolts (BB) with the allen wrench (HH). Attach the socket hex bolt caps (GG).
- Tighten all hex bolts (AA) with the hex wrench (II). Attach the hex bolt caps (FF).

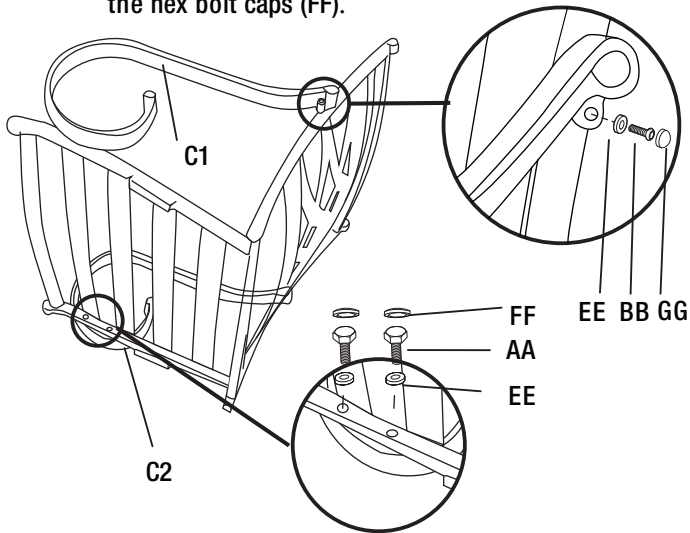

6 Attaching the stem bracket

- Attach the stem bracket (G) to the seat frame (F) using the washers (EE) and hex bolts (CC).
- Ensure all bolts are aligned and assembled correctly.
- Tighten all hex bolts (CC) with the hex wrench (II). Attach the hex bolt caps (FF).

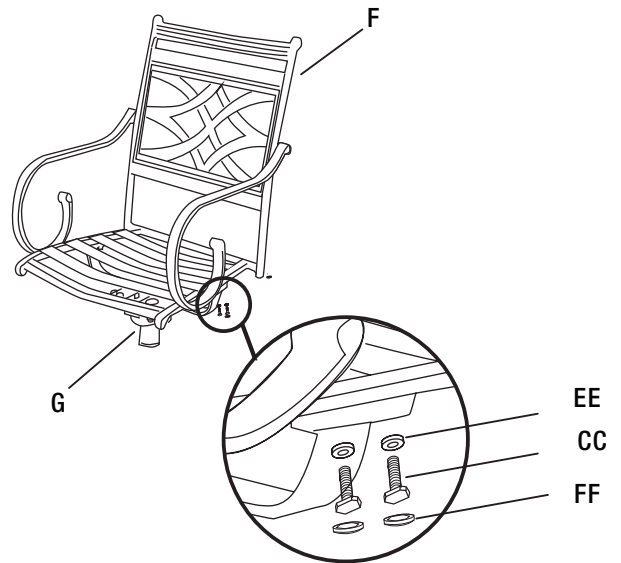

7 Connecting the base and seat

- Place the base (H) on a flat surface and align the stem under the seat frame (F) with the hole on the base. Push down firmly to lock the seat frame (F) and base (H) together.

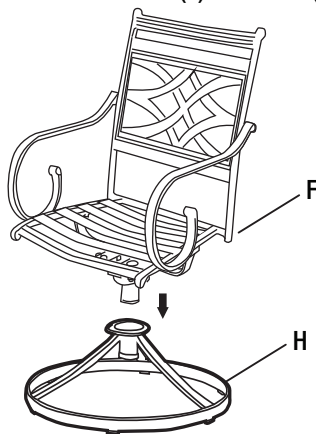

8 Adding the seat cushions

- Place the seat cushions (E) onto the chairs.

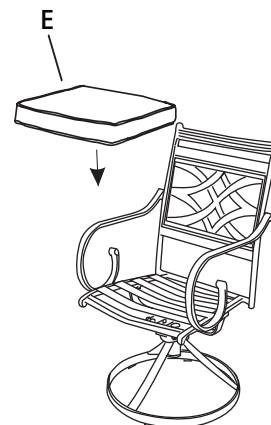

Care and Cleaning

- Do not allow water to build up in frames. This will cause corrosion and possible freezing damage in cold climates.
- Use a mild soap and water for normal cleaning. DO NOT use janitorial or alcohol based cleaners. Some cleaners may be marked as natural, but some ingredients may cause discoloration or have an adverse reaction to your finish.
- Rinse with clean water and dry with a soft, absorbent cloth towel.
- Treat frames with a liquid wax for maximum protection against UV rays and/or salty, damp air.



Questions, problems, missing parts? Before returning to the store,
call Hampton Bay Customer Service
8 a.m. - 7 p.m., EST, Monday-Friday
9 a.m. - 6 p.m., EST, Saturday

1-855-HD-HAMPTON

HAMPTONBAY.COM

Retain this manual for future use.