

# Assembly Instructions

**Caution : You must read this before you proceed**

## **BENCH**

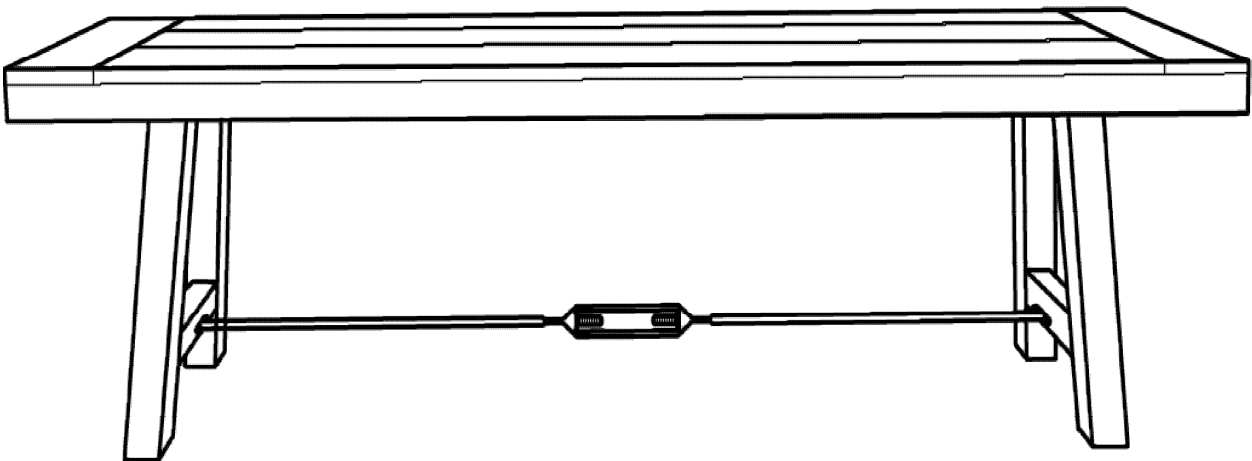

**CAUTION:** This Bench is NOT a TOY.



Keep your child / children at bay during the assembly process.

For moving the Bench and to prevent damage to the Bench, two adults are needed to execute this action.

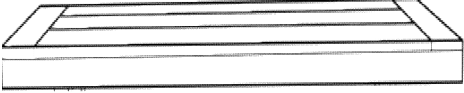
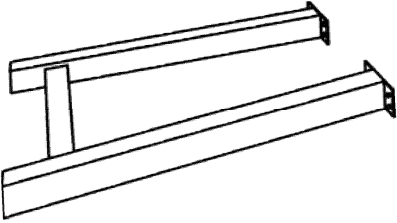
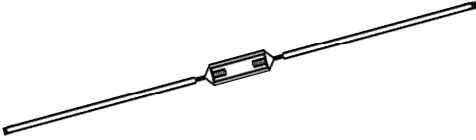
## Parts List

Label	Picture	Description	QTY
A		Seat	1
B		Iron Leg	2
C		Turnbuckle Set	1

## Hardware

Label	Picture	Description	QTY
①		Bolt (M8x20mm)	13
②		Washer	13
③		Allen Key	1

## Assembly Preparation

Before Beginning Assembly:

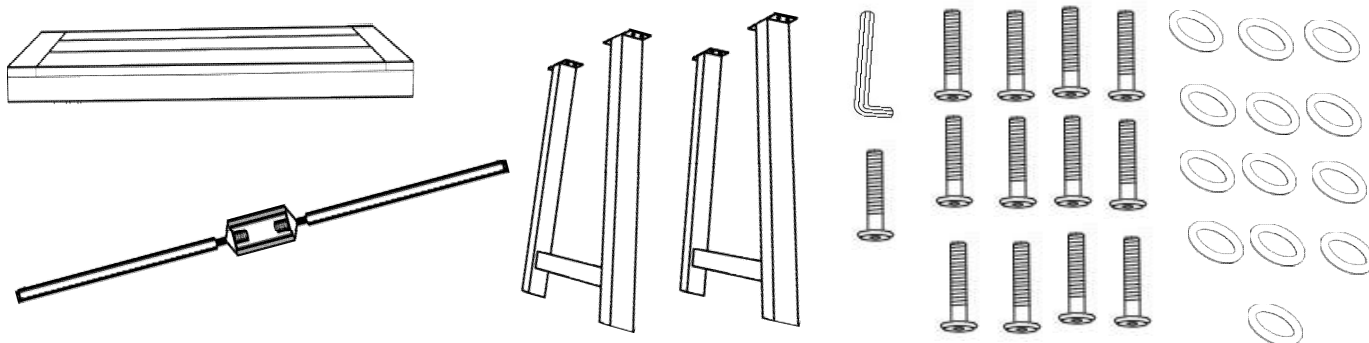

- Read instructions, cover to cover-



- Have 2 adults on hand for assembly-



- Do not assemble on flooring or carpet-



- Assemble on a clean non-marring surface (packing foam)-



- Save all packaging until finished-

## Assembly Steps

### OVERVIEW

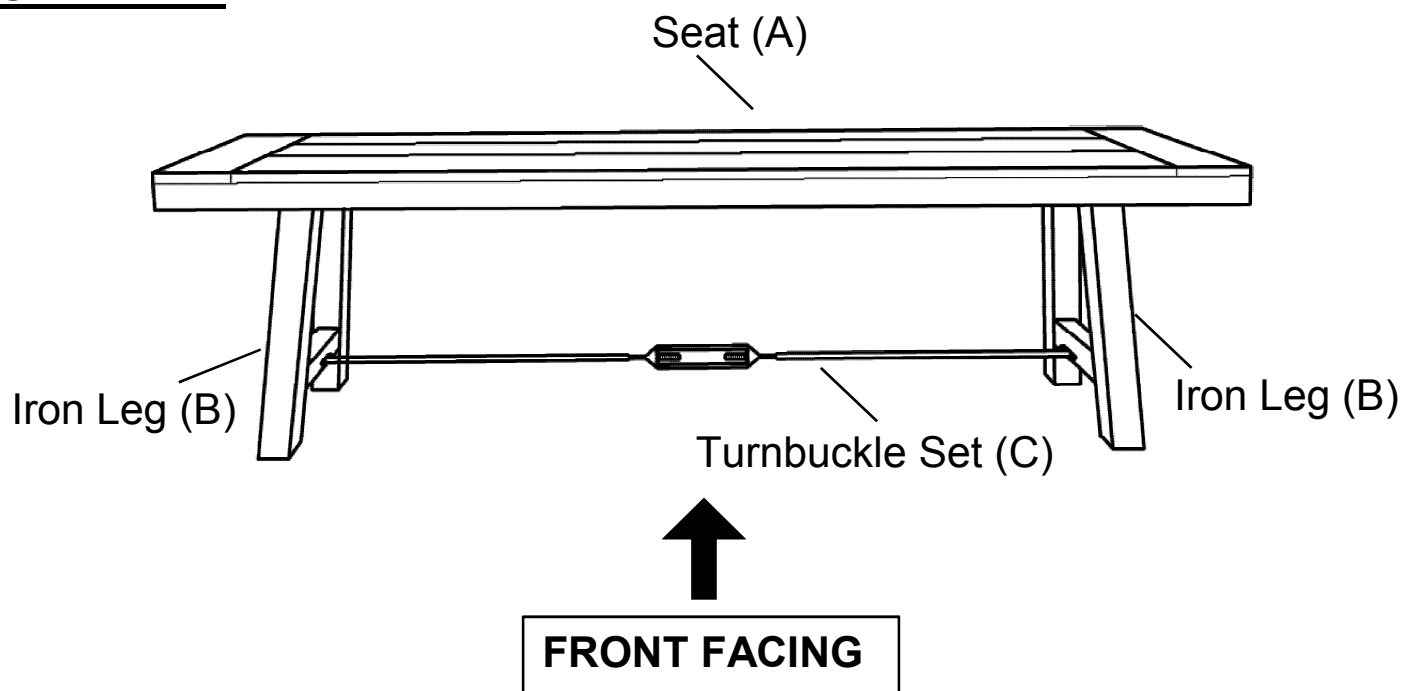

This Bench has multiple parts and may require up to some 30 minutes to assemble. To give you an overview of the Bench parts, the above picture is to help you put the various parts into perspective. Please read through the instructions below to familiarise yourself with the parts and steps before assembly.

## Step 1

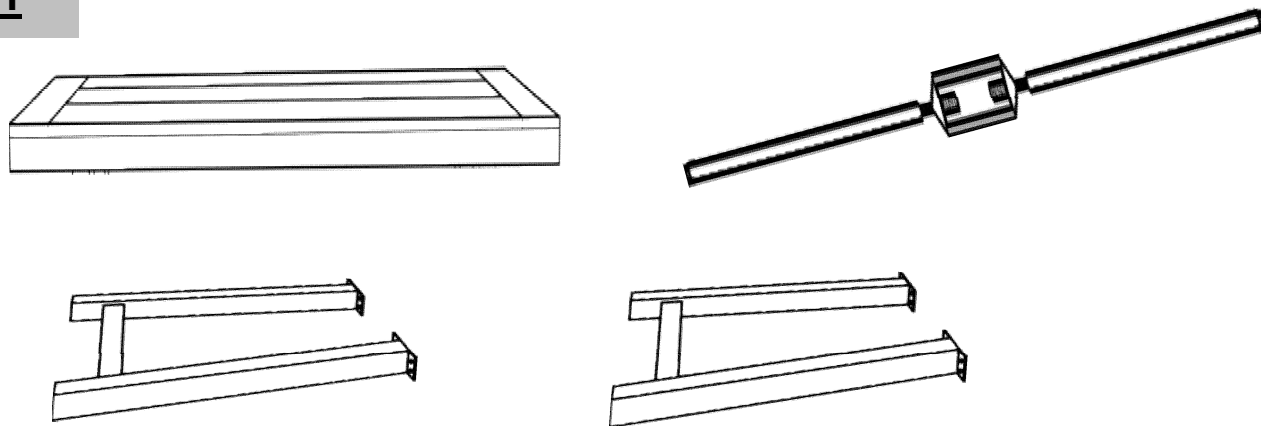

Unpack and place all parts on a clean, non-marring surface.

## Step 2

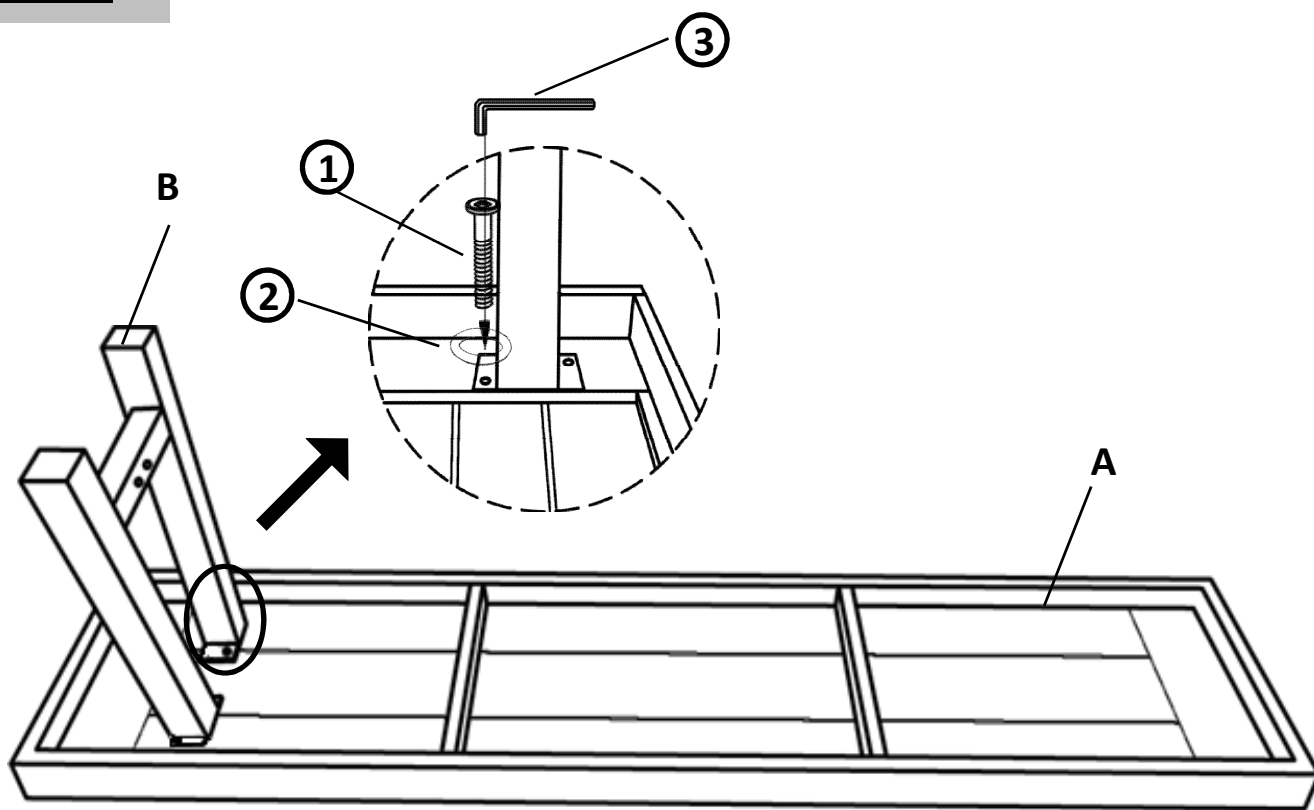

Place the Seat(A) facedown onto a clean, non-marring surface.  
Attach Iron Leg (B) to the Seat(A), using Bolt(①) and Washer(②) with Allen Key(③).

**Notice:** The leg with hole should be face inside against  
**Only loosely tighten the Bolts.**

Repeat the same process with the other Iron Leg(B)

### Step 3

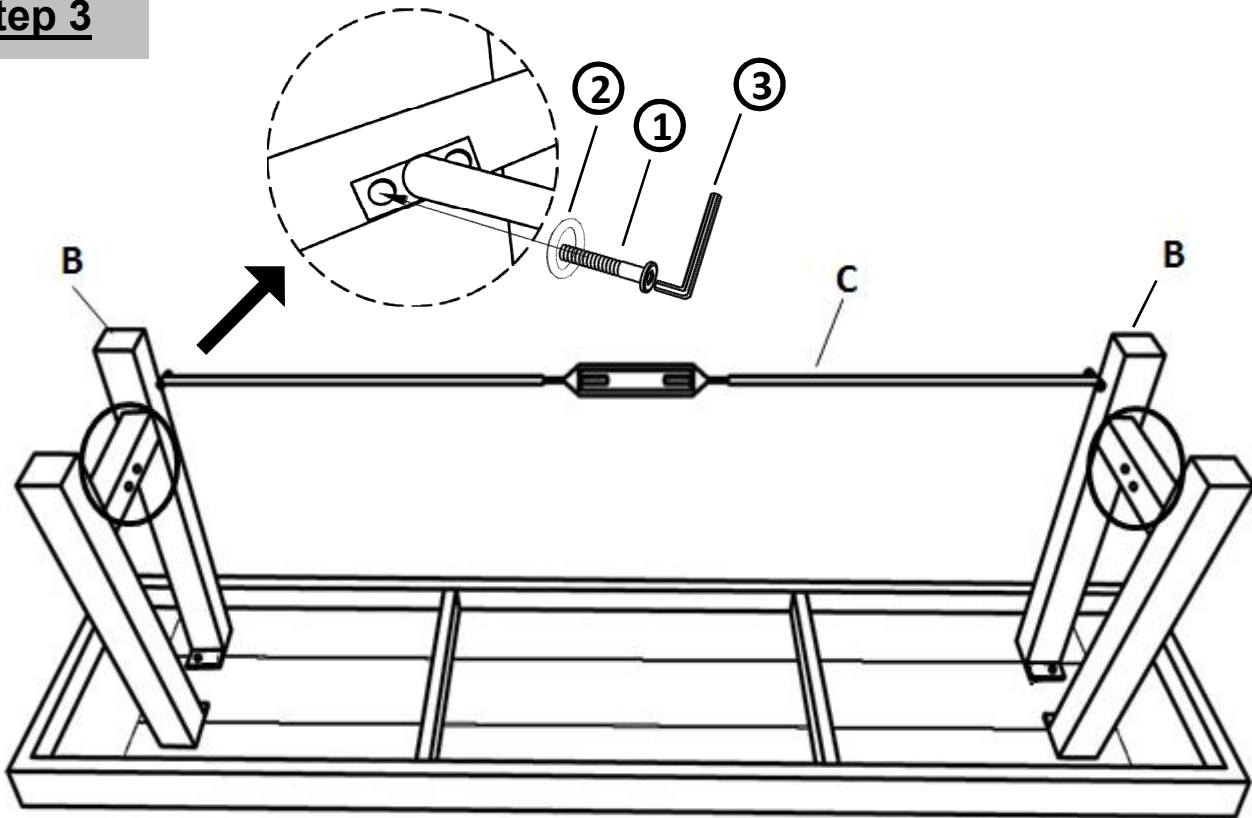

Attach the Turnbuckle Set(C) to the Iron Legs(B) using Bolt(①) and Washer(②) with Allen Key(③).

**Only loosely tighten the Bolts.**

### Step 4

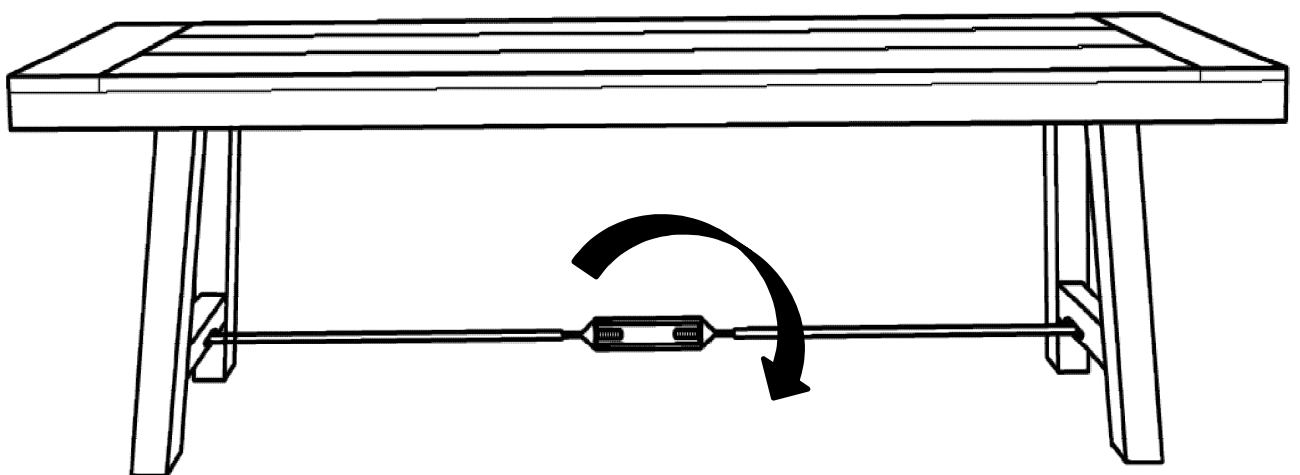

Stand the Bench right side up.

In a sequential manner, tighten all Bolts until fully locked into position.

**Notice:** By hand, turn the Turnbuckle Set(C) to fixed point on Turnbuckle Set(C) to further secure the Bench and maximize stability and show the Turnbuckle Set as place as the picture.

Your Bench is ready for use.

**This Bench can only be used on a flat, level surface.**

## Care & Maintenance



- Do not put hot items directly on furniture surface.



- Do not clean furniture with harsh cleansers or polish.



- To obtain the longest lifespan of your outdoor products, minimizing exposure to direct sunlight is recommended.



- Children should not climb or jump on the furniture.



- Do not write on furniture without a padded barrier to protect the surface.



- To obtain the longest lifespan of your outdoor products, avoid extended and lengthy exposure to rain, snow, and direct sunshine. Whenever possible cover the product and /or place under patio or awnings.



- Not for commercial use. For residential use only .



- Stains may be removed with mild soap solution and damp cloth.



- Dust and pick-up spills using a clean, non-colored, lint-free cloth .