

REVISIONS				
ZONE	REV.	DESCRIPTION	DATE	APPROVED

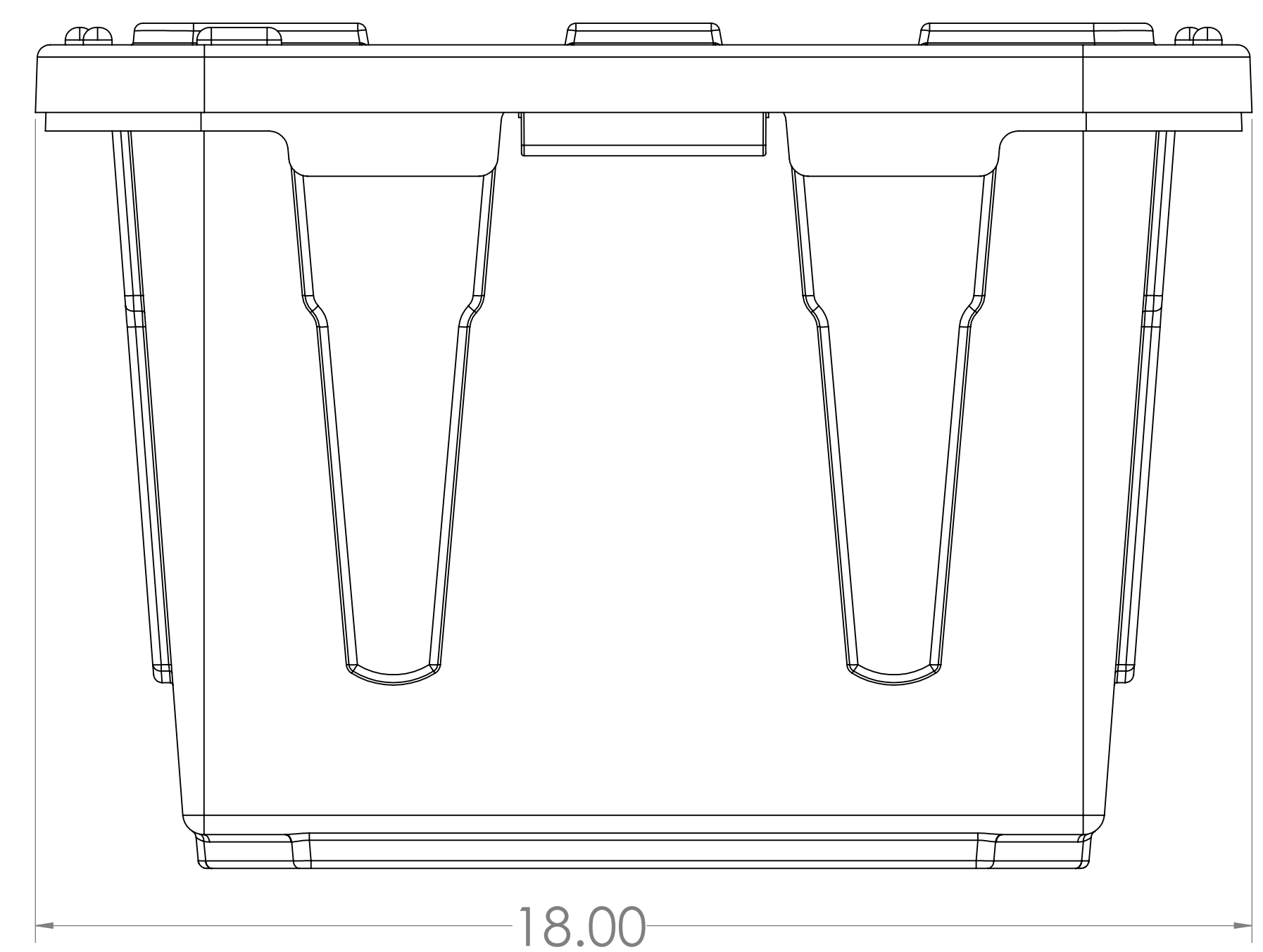
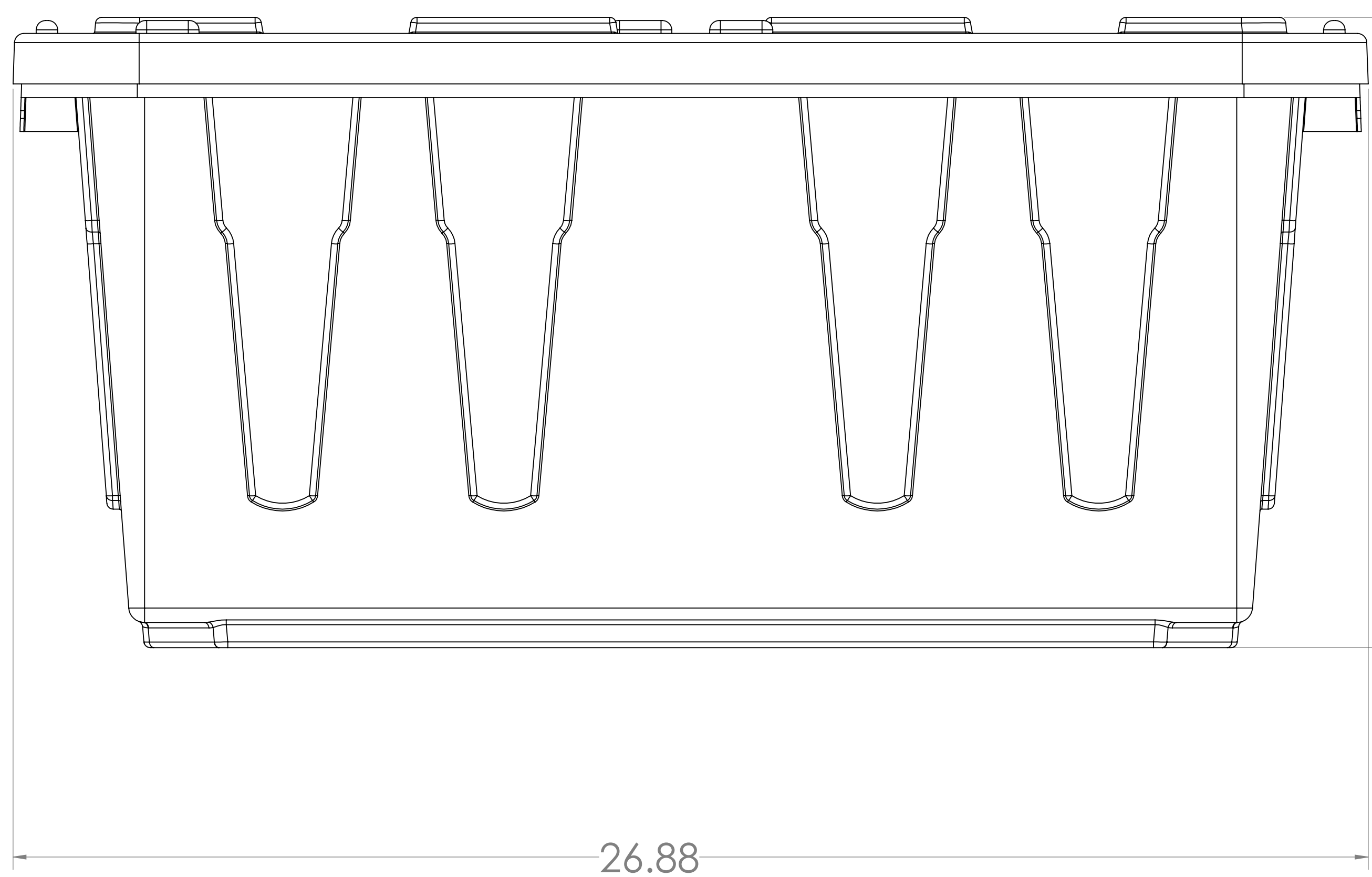
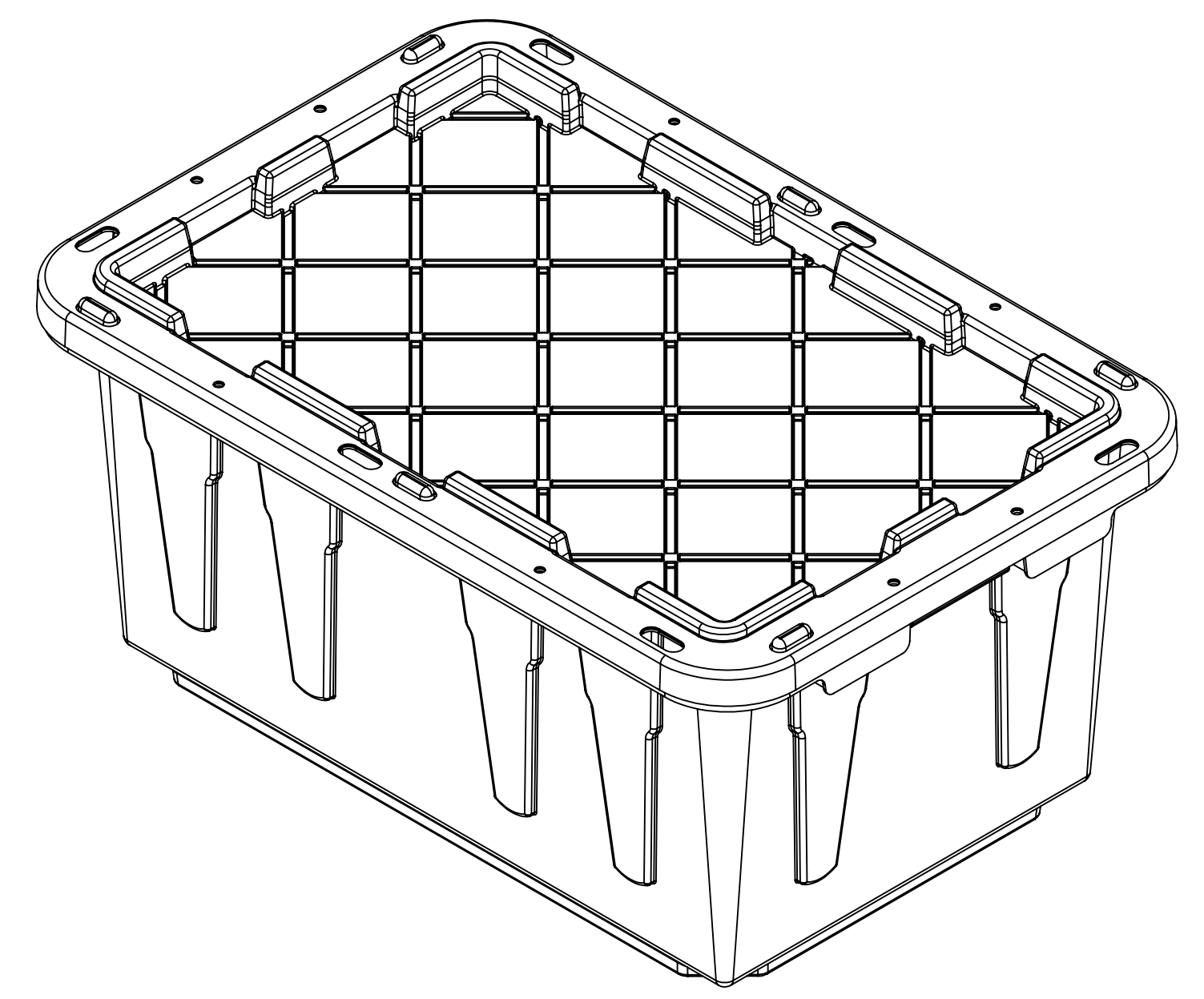
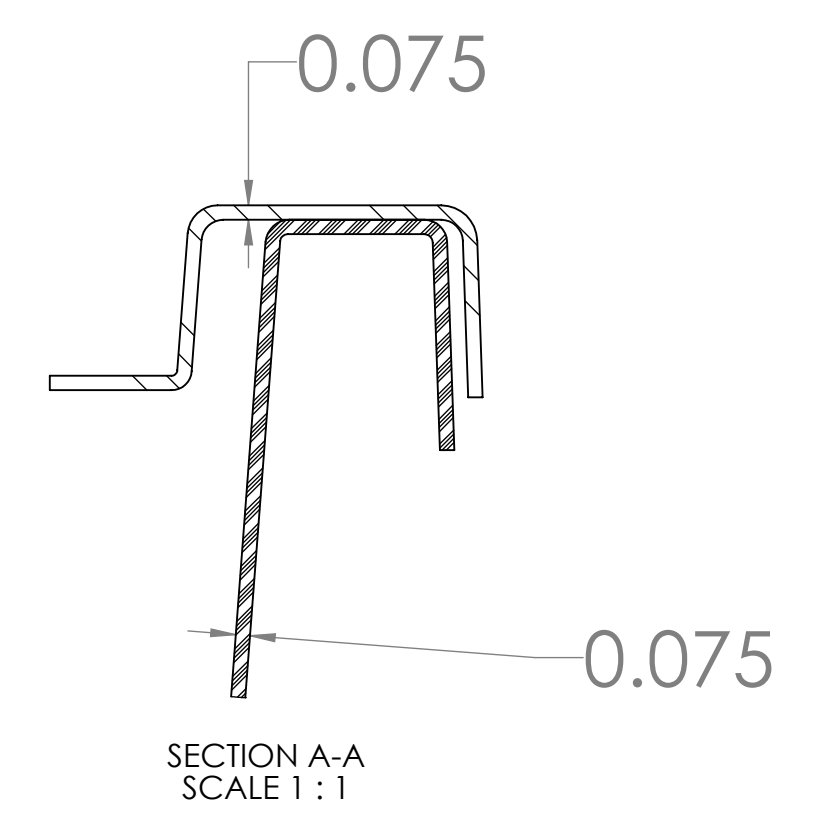
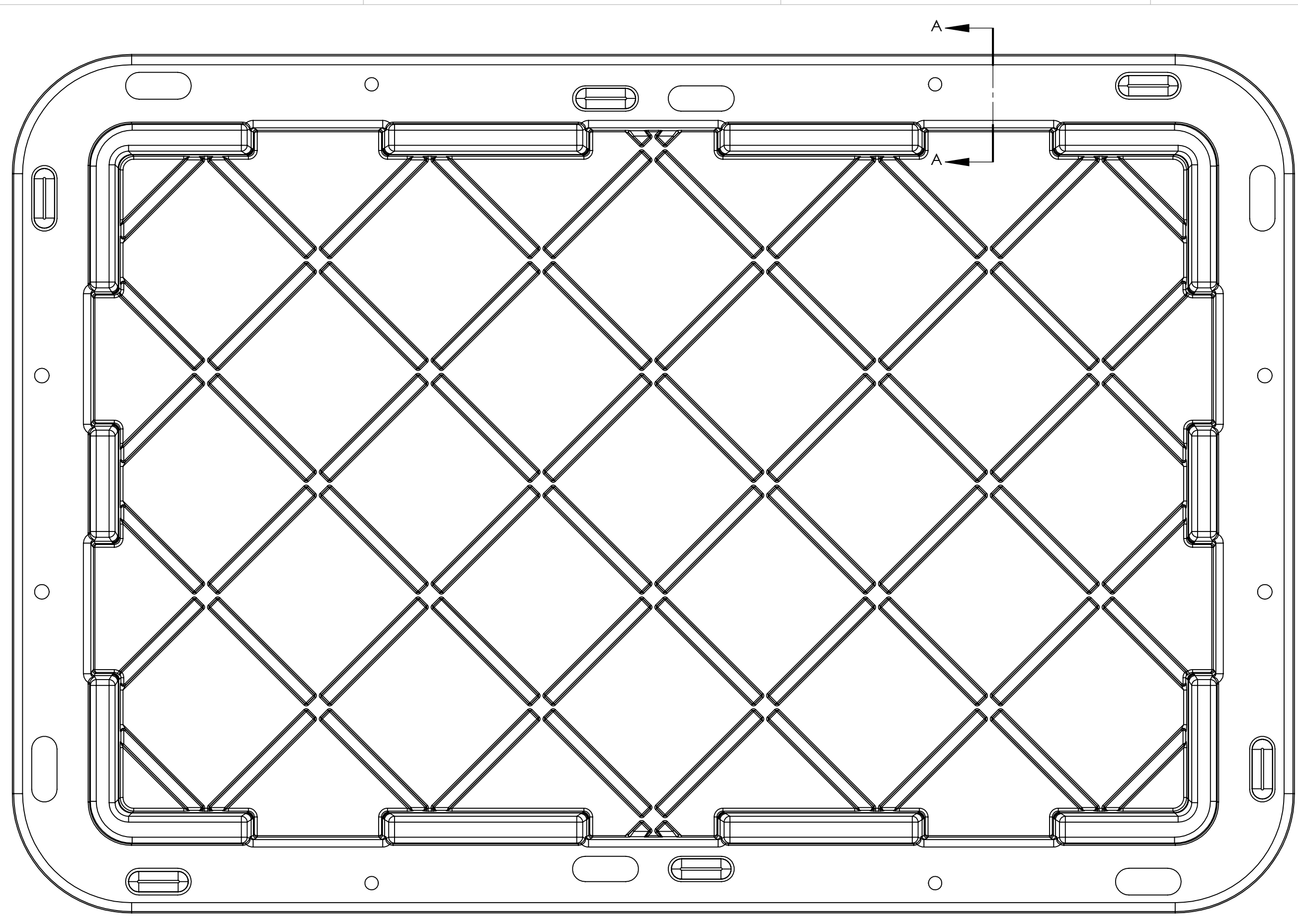

ITEM NO.	DESCRIPTION	Weight	QTY.
1	17 GALLON BIN	3.76	1
2	17 GALLON DIAMOND LID	1.76	1

**PROPRIETARY AND CONFIDENTIAL**  
 THE INFORMATION CONTAINED IN THIS DRAWING IS THE SOLE PROPERTY OF CREATIVE PLASTICS CONCEPTS. ANY REPRODUCTION IN PART OR AS A WHOLE WITHOUT THE WRITTEN PERMISSION OF CREATIVE PLASTICS CONCEPTS IS PROHIBITED.

UNLESS OTHERWISE SPECIFIED:		NAME	DATE
DRAWN			
CHECKED			
ENG APPR.			
MFG APPR.			
INTERPRET GEOMETRIC TOLERANCING PER:		Q.A.	
MATERIAL		COMMENTS:	
NEXT ASSY	USED ON	FINISH	
APPLICATION			

**CREATIVE PLASTIC**  
 C.O.P.C. P.L.C.

TITLE:  
**17 GALLON BIN ASSEMBLY**

SIZE DWG. NO. REV  
**D**

SCALE: 1:2 WEIGHT: 5.52 SHEET 1 OF 1

REVISIONS				
ZONE	REV.	DESCRIPTION	DATE	APPROVED

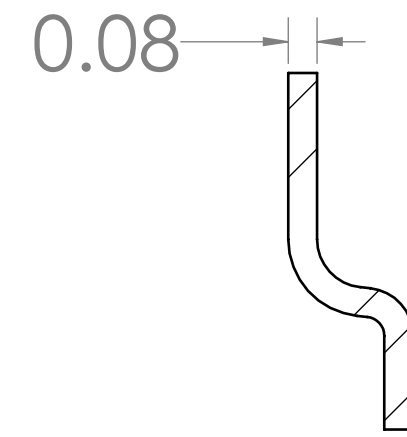
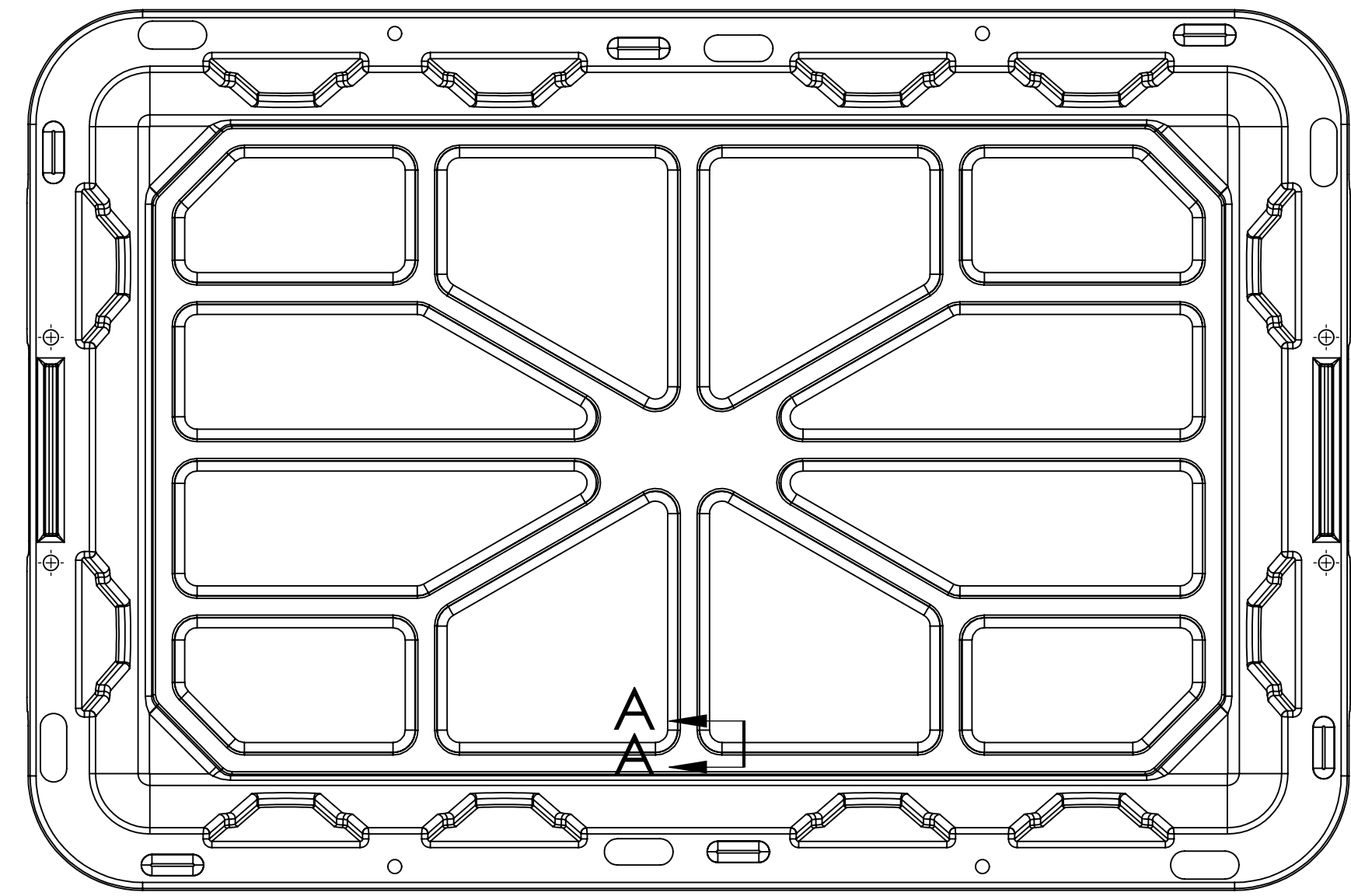

SECTION A-A  
SCALE 2:1

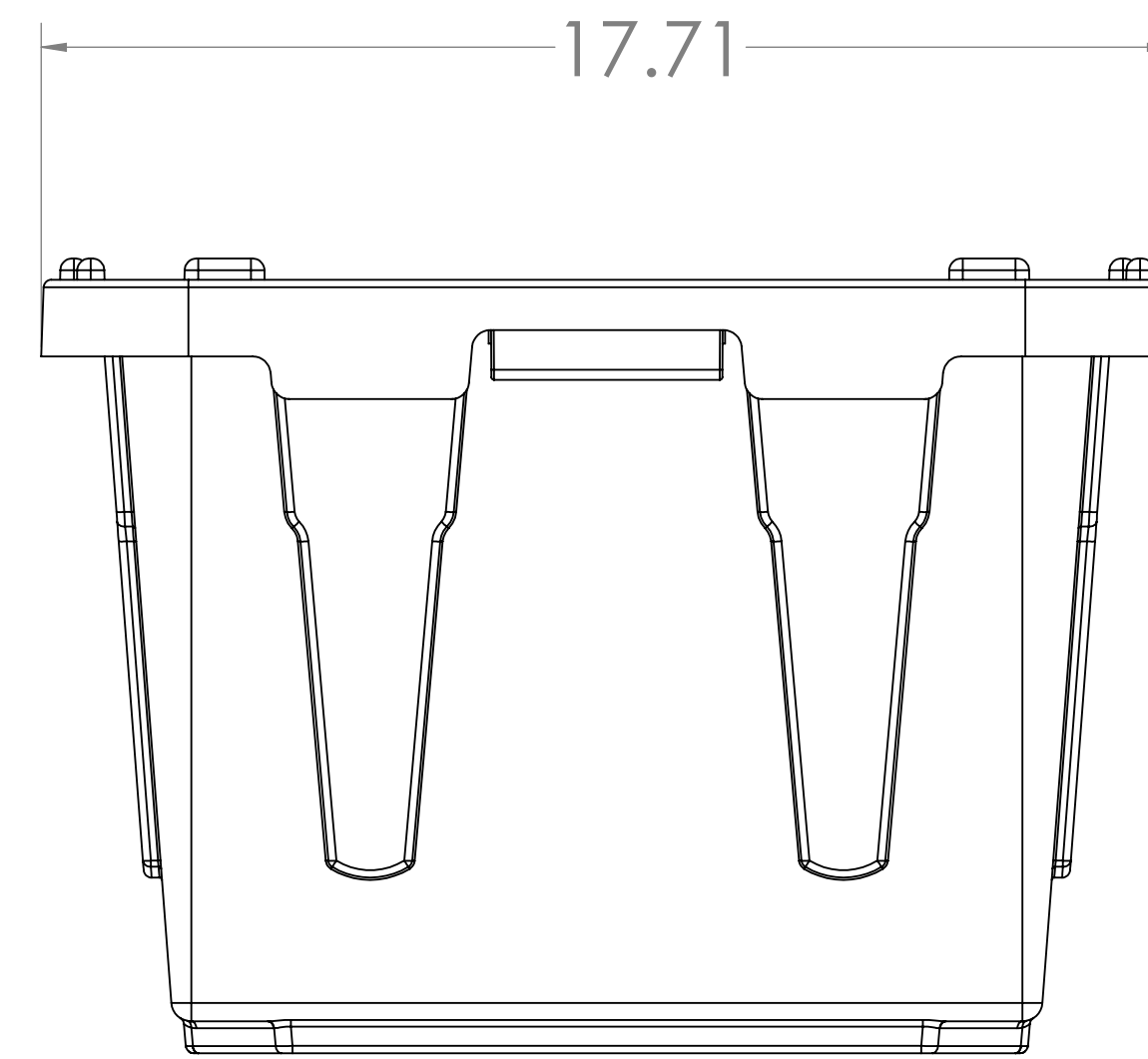
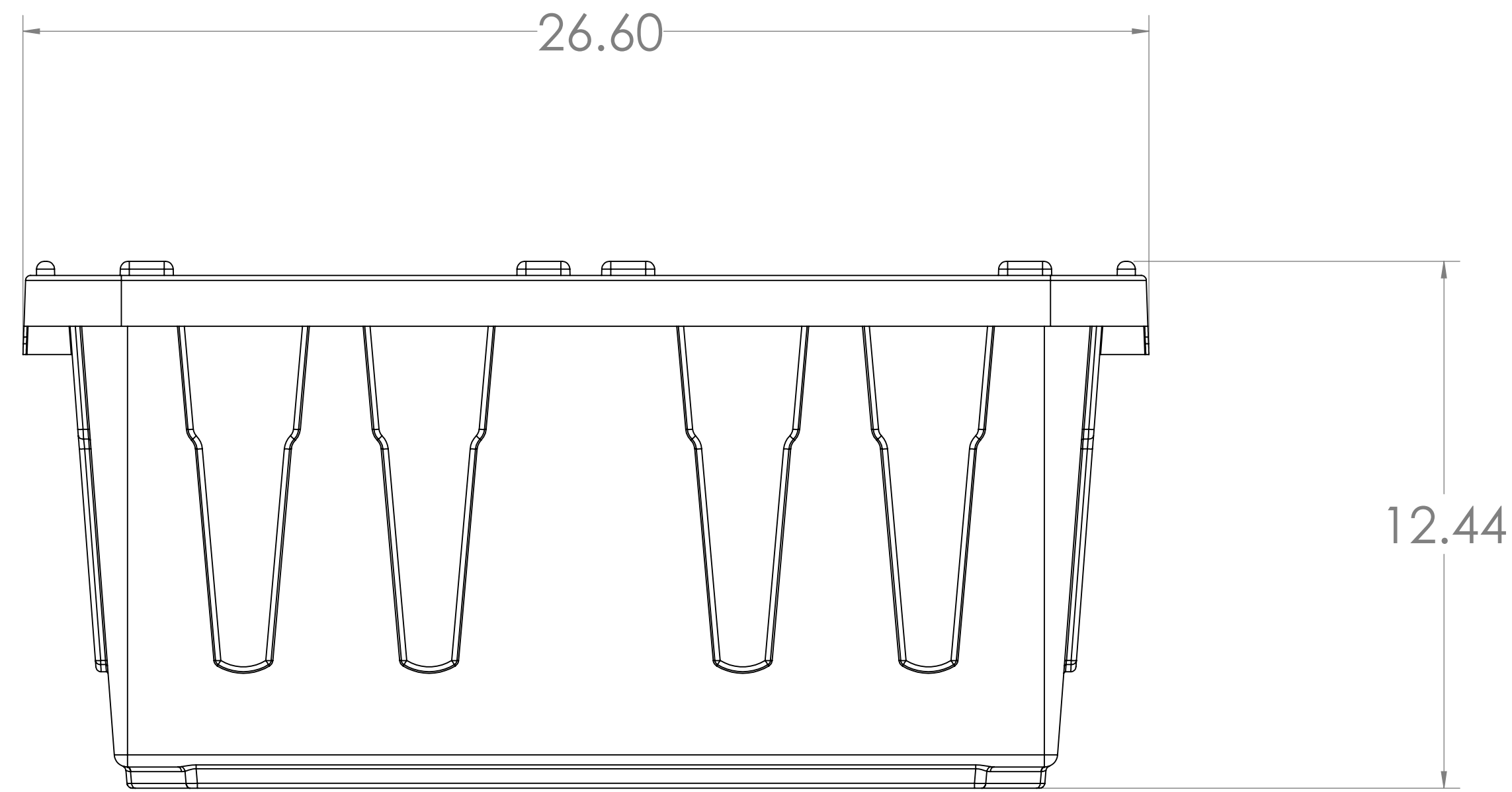
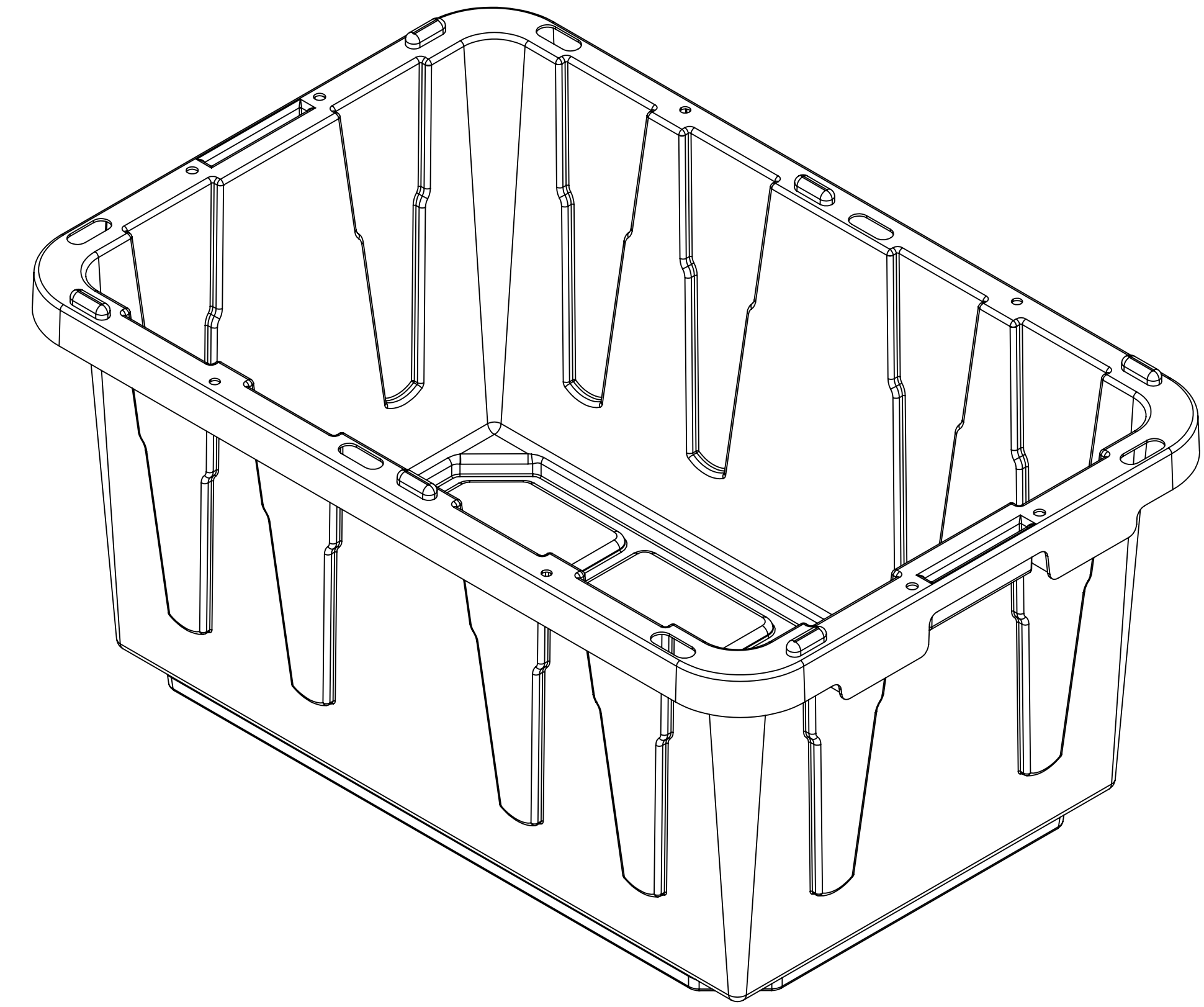

ITEM NO.	DESCRIPTION	Weight	QTY.
1	17 GALLON BIN	3.76	1

UNLESS OTHERWISE SPECIFIED:		NAME	DATE
DIMENSIONS ARE IN INCHES			
TOLERANCES:			
FRACTIONAL ±		DRAWN	
ANGULAR MATCH ±		CHECKED	
TWO PLACE DECIMAL ±		ENG APPR.	
THREE PLACE DECIMAL ±		MFG APPR.	
INTERPRET GEOMETRIC TOLERANCING PER:		Q.A.	
MATERIAL		COMMENTS:	
PP Homopolymer			
FINISH			
NEXT ASSY	USED ON		
APPLICATION			

**PROPRIETARY AND CONFIDENTIAL**  
THE INFORMATION CONTAINED IN THIS DRAWING IS THE SOLE PROPERTY OF CREATIVE PLASTICS CONCEPTS. ANY REPRODUCTION IN PART OR AS A WHOLE WITHOUT THE WRITTEN PERMISSION OF CREATIVE PLASTICS CONCEPTS IS PROHIBITED.



TITLE:  
17 GALLON BIN

SIZE DWG. NO. REV  
D  
SCALE: 1:4 WEIGHT: 3.76 SHEET 1 OF 1