



User Manual

Read and understand this manual before using machine.

10" CABINET SAW



STEEL CITY TOOL WORKS
VER. 06.11

Model Number
35951G
35951C

User can option 30" & 50" rail
with fence

Manual Part No. SC76077

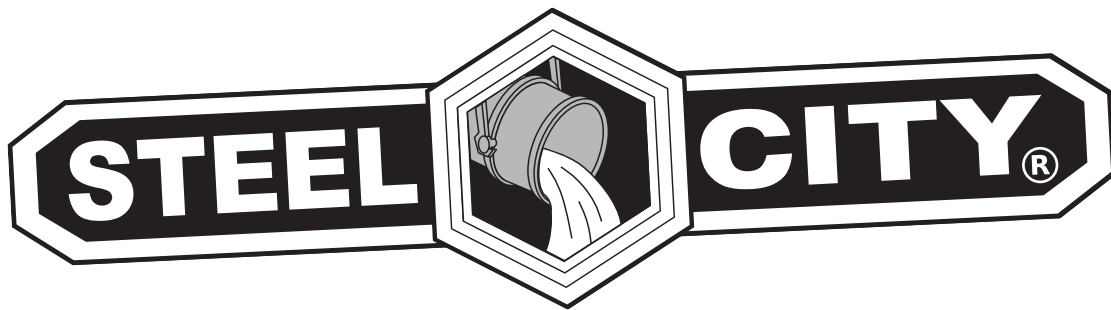

THANK YOU for purchasing your new Steel City Table Saw. This table saw has been designed, tested, and inspected with you, the customer, in mind. When properly used and maintained, your table saw will provide you with years of trouble free service, which is why it is backed by one of the longest machinery warranties in the business.

This table saw is just one of many products in the Steel City's family of woodworking machinery and is proof of our commitment to total customer satisfaction.

At Steel City we continue to strive for excellence each and every day and value the opinion of you, our customer. For comments about your table saw or Steel City Tool Works, please visit our web site at www.steelcitytoolworks.com.

TABLE OF CONTENTS

INTRODUCTION

SECTION 1	Warranty	4
SECTION 2	Product Specifications	7
SECTION 3	Accessories and Attachments	7
SECTION 4	Definition of Terms	8
SECTION 5	Feature Identification	9
SECTION 6	General Safety	10
SECTION 7	Product Safety	12
SECTION 8	Electrical Requirements.....	13
SECTION 9	Grounding Instructions.....	14
SECTION 10	Unpacking & Inventory.....	15
SECTION 11	Assembly	17
SECTION 12	Adjustments.....	23
SECTION 13	Operation.....	27
SECTION 14	Maintenance	32
SECTION 15	Troubleshooting Guide.....	33
SECTION 16	Parts List.....	35

INTRODUCTION

This user manual is intended for use by anyone working with this machine. It should be kept available for immediate reference so that all operations can be performed with maximum efficiency and safety. Do not attempt to perform maintenance or operate this machine until you have read and understand the information contained in this manual.

The drawings, illustrations, photographs, and specifications in this user manual represent your machine at time of print. However, changes may be made to your machine or this manual at any time with no obligation to Steel City Tool Works.

WARRANTY

STEEL CITY TOOL WORKS 5 YEAR LIMITED WARRANTY

Steel City Tool Works, LLC ("SCTW") warrants this "STEEL CITY TOOL WORKS" machinery to be free of defects in workmanship and materials for a period of 5 years from the date of the original retail purchase by the original owner. (Granite components are warranted for 10 years. Please inform SCTW within 30 days for any damages or defects on the Granite components found upon receipt of the products to qualify for the 10 year limited warranty. See the Granite warranty statement supplied with those products.)

Important Notice:

- Proof of Purchase must be present when requesting Warranty service.
- All warranty communications should be directed to Steel City Tool Works Technical Service 1-877-724-8665.
- Warranty Card must be completed and returned within 90 Days from original Purchase Date.

What is covered under the 5 year Limited Warranty:

- This warranty covers all defects in workmanship or materials and normal wear items such as motors, switches, cords, gears and bearings for 2 years following the date of purchase of the tool. Warranties on other Steel City Tools may vary.

How to get Service:

- To obtain service for this Steel City Tool you must return it; Freight Prepaid, or take in to an authorized service center for Steel City Tools. You may obtain the Service Location or Service Technician location nearest to you by calling (toll free) 1-877-724-8665.
- When requesting warranty service you must present the original dated sales receipt and Date code, which can be found on the original carton and machine body. SCTW will repair or replace, at its expense and at its option, any SCTW machine, machine part (Motor, Switch and Cords), or machine accessory which in normal use has proven to be defective.

What is not covered:

- This warranty applies only to the original purchaser at retail and may not be transferred. This warranty only covers defects arising from normal usage and does not cover any malfunction, failure or defect resulting from misuse, abuse, neglect, alteration, modification or repair by other than an authorized Service Center or Technician of Steel City Tool Works. Consumable accessories provided with the tool such as, but not limited to , brushes, blades, belts, bits are not covered.
- Steel City Tool Works make No Warranties, Representations or Promises as to the Quality or Performance of its Power Tools other than those specifically stated in this Warranty.

Except as set forth above, SCTW makes no express or implied representations or warranties with respect to its machinery, or its condition, merchant-ability, or fitness for any particular purpose or use. SCTW furnishes the above warranties in lieu of all other warranties, express or implied, including the warranties of merchantability and fitness for a particular purpose, which are hereby specifically disclaimed. SCTW shall not be liable for any (a) special, indirect, incidental, punitive or consequential damages, including without limitation loss of profits, arising from or related to this warranty, the breach of any agreement or warranty, or the operation or use of its machinery, including without limitation damages arising from damage to fixtures , tools , equipment, parts or materials, direct or indirect loss caused by any other party, loss of revenue or profits, financing or interest charges , and claims by any third person, whether or not notice of such possible damages has been given to SCTW; (b) damages of any kind for any delay by or failure of SCTW to perform its obligations under this agreement ; or (c) claims made a subject of a legal proceeding against SCTW more than one (1) year after such cause of action first arose.

The validity, construction and performance of this Warranty and any sale of machinery by SCTW shall be governed by the laws of the Commonwealth of Pennsylvania, without regard to conflicts of law's provisions of any jurisdiction. Any action related in any way to any alleged or actual offer, acceptance or sale by SCTW, or any claim related to the performance of any agreement including without limitation this Warranty, shall take place in the federal or state courts in Allegheny County, Pennsylvania.

WARRANTY CARD

Name _____
 Street _____
 Apt. No. _____
 City _____ State _____ Zip _____
 Phone Number _____
 E-Mail _____

Product Description: _____
 Model No.: _____ Serial No.: _____

NOTE: The **Proof of Purchase** must be submitted along with this card in order to have the Warranty to take into effect. Fail to submit the Proof of Purchase may invalidate your Product Warranty.

The following information is given on a voluntary basis and is strictly confidential.

1. Where did you purchase your STEEL CITY machine?
 Store: _____
 City: _____ Online: _____

2. How did you first learn of Steel City Tool Works?
 Advertisement Mail Order Catalog
 Web Site Friend
 Local Store Other _____

3. Which of the following magazines do you subscribe to?
 American Woodworker Cabinetmaker
 Canadian Woodworking Family Handyman
 Fine Homebuilding Fine Woodworking
 Journal of Light Construction Old House Journal
 Popular Mechanics Popular Science
 Popular Woodworking Today's Homeowner
 WOOD Woodcraft
 WOODEN Boat Woodshop News
 Woodsmith Woodwork
 Woodworker Woodworker's Journal
 Workbench Other _____

4. Which of the following woodworking / remodeling shows do you watch?
 Backyard America The American Woodworker
 Home Time The New Yankee Workshop
 This Old House Woodwright's Shop
 Other _____

5. What is your annual household income?
 \$20,000 to \$29,999 \$30,000 to \$39,999
 \$40,000 to \$49,999 \$50,000 to \$59,999
 \$60,000 to \$69,999 70,000 to \$79,999
 \$80,000 to \$89,999 \$90,000 +

6. What is your age group?
 20 to 29 years 30 to 39 years
 40 to 49 years 50 to 59 years
 60 to 69 years 70 + years

7. How long have you been a woodworker?
 0 to 2 years 2 to 8 years
 8 to 20 years over 20 years

8. How would you rank your woodworking skills?
 Simple Intermediate
 Advance Master Craftsman

9. How many Steel City machines do you own? _____

10. What stationary woodworking tools do you own?
Check all that apply.
 Air Compressor Band Saw
 Drill Press Drum Sander
 Dust Collection Horizontal Boring Machine
 Jointer Lathe
 Mortiser Panel Saw
 Planer Power Feeder
 Radial Arm Saw Shaper
 Spindle Sander Table Saw
 Vacuum Veneer Press Wide Belt Sander
 Other _____

11. Which benchtop tools do you own? *Check all that apply.*
 Belt Sander Belt / Disc Sander
 Drill Press Band Saw
 Grinder Mini Jointer
 Mini Lathe Scroll Saw
 Spindle / Belt Sander Other _____

12. Which portable / hand held power tools do you own?
Check all that apply.
 Belt Sander Biscuit Jointer
 Dust Collector Circular Saw
 Detail Sander Drill / Driver
 Miter Saw Orbital Sander
 Palm Sander Portable Thickness Planer
 Saber Saw Reciprocating Saw
 Router Other _____

13. What machines / accessories would you like to see added to the STEEL CITY line?

14. What new accessories would you like to see added?

15. Do you think your purchase represents good value?
 Yes No

16. Would you recommend STEEL CITY products to a friend?
 Yes No

17. Comments:

CUT HERE

FOLD ON DOTTED LINE

PLACE
STAMP
HERE

Steel City Tool Works
821 Bluff Road
Romeoville, IL, 60446

FOLD ON DOTTED LINE

PRODUCT SPECIFICATION

	<u>Model 35951G</u>	<u>Model 35951C</u>
Motor type	Induction	Induction
HP	1.75	1.75
Amps	15 /7.5	15 /7.5
Volts	120 / 240	120 / 240
Hertz	60	60
RPM	3450	3450
Blade Tilt	Left	Left
Blade Drive	Poly-V Belt	Poly-V Belt
Blade Dimeter	10-in	10-in
Blade Arbor	5/8-in	5/8-in
Number of Teeth	40	40
Blade Speed	3450	3450
Max Depth of cut at 90°	3-3/8-in	3-3/8-in
Max Depth of cut at 45°	2-1/4-in	2-1/4-in
Table in front of blade at max depth of cut	12-1/2-in	12-1/2-in
Max Dado width	13/16-in	13/16-in
Max Dado blade diameter	8-in	8-in
Left Extention table wing	15.7-in Granite	15.7-in Cast Iron
Rigjht Extention table wing	16.9-in Granite	16.9-in Cast Iron
Main Table	11.5-in Granite	11.5-in Cast Iron

Product Dimensions - Cabinet

Length	42-in	42-in
Width	27-in	27-in
Height (This is height from floor to table top.)	34-1/2-in (with Wheel)	34-1/2-in (with Wheel)
Net Weight	335 lbs	282 lbs

Product Dimensions - Crate

Length	31-in	31-in
Width	31in	31-in
Height	43-in	43-in
Net Weight	384 lbs	331 lbs

ACCESSORIES AND ATTACHMENTS

Dado Insert:	35830
Zero Clearance Insert:	35831

There are more accessories available for your Steel City Product. For more information on any accessories associated with this and other machines, please contact your nearest Steel City distributor, or visit our website at: www.steelcitytoolworks.com.

DEFINITION OF TERMS

Anti-Kickback Fingers– A safety device attached to the blade guard and splitter assembly designed to minimize the chance of a workpiece being thrown back during a cutting operation.

Arbor – The shaft on which the blade or accessory cutting-tool is mounted.

Bevel Cut– The operation of making any cut with the blade set on a degree other than 90 degrees.

Compound Cut– The operation of making both a bevel and a miter cut at one time.

Crosscut– The operation of making a cut across the grain or width of a workpiece.

Dado – A non-through cut that produces a square notch. A dado is typically from 1/8-in. to 13/16-in. wide. A dado requires a special set of blades, not included with this table saw.

Featherboard– An accessory device that can be made or purchased to help guide or hold down a workpiece during cutting operations.

Freehand – A very dangerous operation of making a cut without using the fence or miter gauge in a cutting operation. **FREEHAND CUTS MUST NEVER BE PERFORMED ON A TABLE SAW.**

Gum, Pitch or Resin– A sticky, sap based residue that comes from wood products.

Heeling – The misalignment of the blade to the miter slots; when the blade is not parallel to the miter slots.

Kerf – The material removed by the blade in the workpiece during any cutting operation.

Kickback– When the workpiece is thrown back toward the operator at a high rate of speed during a cutting operation.

Miter Cut– The operation of making a cut using the miter gauge at any angle other than zero degrees.

Push Stick– An accessory device that can be made or purchased to help push the workpiece through the blade. A push stick is used to keep the operator's hands away from the blade when ripping a narrow workpiece.

Rabbet – A square notch in the edge of the workpiece.

Rip Cut – The operation of making a cut with the grain of the workpiece.

Saw Blade Path– The area that is directly in line with the blade, including area over, under, behind and in front of it.

Set of the Saw Blade– The distance that the tips of the saw blade are angled outwards from the thickness of the blade. The set of the saw blade teeth allows for the blade body to pass safely through all cuts.

Table/Work Area– The total surface of the top of the table saw on which the workpiece rests while set-up or cutting operations are being performed.

FEATURE IDENTIFICATION

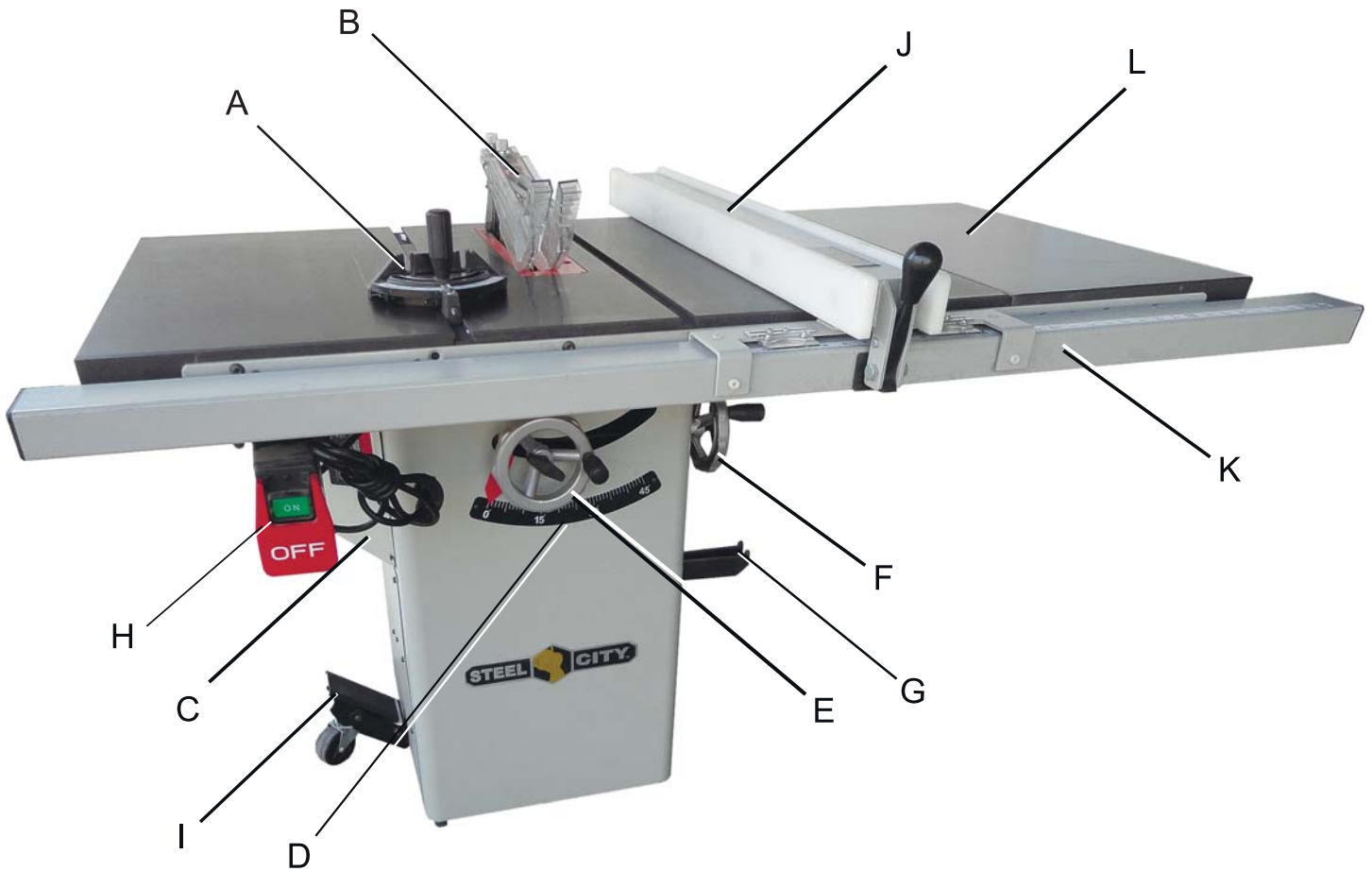

- A) Miter Gauge
- B) Blade Guard Assembly with Riving Knife
- C) Motor Cover
- D) Bevel Scale
- E) Height Adjustment Handwheel
- F) Bevel Adjustment Handwheel
- G) Fence Hooks
- H) On/Off Switch
- I) Mobile Base Caster Assembly
- J) Fence (Optional)
- K) 30" or 50" Rail (Optional)
- L) 12" or 34" Table Board (Optional)

GENERAL SAFETY

WARNING

TO AVOID serious injury and damage to the machine, read and follow all Safety and Operating Instructions before assembling and operating this machine.

This manual is not totally comprehensive. It does not and can not convey every possible safety and operational problem which may arise while using this machine. The manual will cover many of the basic and specific safety procedures needed in an industrial environment.

All federal and state laws and any regulations having jurisdiction covering the safety requirements for use of this machine take precedence over the statements in this manual. Users of this machine must adhere to all such regulations.

Below is a list of symbols that are used to attract your attention to possible dangerous conditions.



This is the safety alert symbol. It is used to alert you to potential personal injury hazards. Obey all safety messages that follow this symbol to avoid possible injury or death.

DANGER

Indicates an imminently hazardous situation which, if not avoided, **WILL** result in death or serious injury.

WARNING

Indicates a potentially hazardous situation which, if not avoided, **COULD** result in death or serious injury.

CAUTION

Indicates a potentially hazardous situation, if not avoided, **MAY** result in minor or moderate injury. It may also be used to alert against unsafe practices.

CAUTION

CAUTION used without the safety alert symbol indicates a potentially hazardous situation which, if not avoided, may result in property damage.

NOTICE

This symbol is used to alert the user to useful information about proper operation of the machine.

WARNING

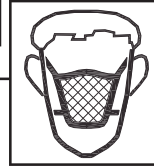

Exposure to the dust created by power sanding, sawing, grinding, drilling and other construction activities may cause serious and permanent respiratory or other injury, including silicosis (a serious lung disease), cancer, and death. Avoid breathing the dust, and avoid prolonged contact with dust. The dust may contain chemicals known to the State of California to cause cancer, birth defects or other reproductive harm.

Some examples of these chemicals are:

- Lead from lead-based paints.
- Crystalline silica from bricks, cement and other masonry products.
- Arsenic and chromium from chemically-treated lumber.

Always operate tool in well ventilated area and provide for proper dust removal. Use a dust collection system along with an air filtration system whenever possible. Always use properly fitting NIOSH/OSHA approved respiratory protection appropriate for the dust exposure, and wash exposed areas with soap and water.

1. To avoid serious injury and damage to the machine, read the entire User Manual before assembly and operation of this machine.

WARNING

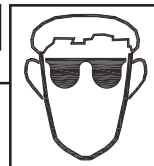

2. **ALWAYS** wear eye protection. Any machine can throw debris into the eyes during operations, which could cause severe and permanent eye damage. Everyday eyeglasses are **NOT** safety glasses. **ALWAYS** wear Safety Goggles (that comply with ANSI standard Z87.1) when operating power tools.

▲ WARNING

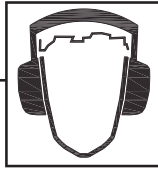

3. **ALWAYS** wear hearing protection. Plain cotton is not an acceptable protective device. Hearing equipment should comply with ANSI S3.19 Standards.

▲ WARNING

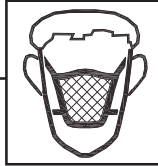

4. **ALWAYS** wear a NIOSH/OSHA approved dust mask to prevent inhaling dangerous dust or airborne particles.

5. **ALWAYS** keep the work area clean, well lit, and organized. **DO NOT** work in an area that has slippery floor surfaces from debris, grease, and wax.
6. **ALWAYS** unplug the machine from the electrical receptacle when making adjustments, changing parts or performing any maintenance.
7. **AVOID ACCIDENTAL STARTING.** Make sure that the power switch is in the "OFF" position before plugging in the power cord to the electrical receptacle.

▲ WARNING

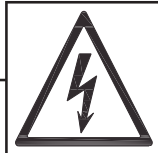

8. **AVOID** a dangerous working environment. **DO NOT** use electrical tools in a damp environment or expose them to rain or moisture.

▲ WARNING



9. **CHILDPROOF THE WORKSHOP AREA** by removing switch keys, unplugging tools from the electrical receptacles, and using padlocks.

10. **DO NOT** use electrical tools in the presence of flammable liquids or gasses.

11. **DO NOT FORCE** the machine to perform an operation for which it was not designed. It will do a safer and higher quality job by only performing operations for which the machine was intended.
12. **DO NOT** stand on a machine. Serious injury could result if it tips over or you accidentally contact any moving part.
13. **DO NOT** store anything above or near the machine.
14. **DO NOT** operate any machine or tool if under the influence of drugs, alcohol, or medication.
15. **EACH AND EVERY** time, check for damaged parts prior to using any machine. Carefully check all guards to see that they operate properly, are not damaged, and perform their intended functions. Check for alignment, binding or breakage of all moving parts. Any guard or other part that is damaged should be immediately repaired or replaced.
16. Ground all machines. If any machine is supplied with a 3-prong plug, it must be plugged into a 3-contact electrical receptacle. The third prong is used to ground the tool and provide protection against accidental electric shock. **DO NOT** remove the third prong.
17. Keep visitors and children away from any machine. **DO NOT** permit people to be in the immediate work area, especially when the machine is operating.
18. **KEEP** protective guards in place and in working order.
19. **MAINTAIN** your balance. **DO NOT** extend yourself over the tool. Wear oil resistant rubber soled shoes. Keep floor clear of debris, grease, and wax.
20. **MAINTAIN** all machines with care. **ALWAYS KEEP** machine clean and in good working order. **KEEP** all blades and tool bits sharp.
21. **NEVER** leave a machine running, unattended. Turn the power switch to the OFF position. **DO NOT** leave the machine until it has come to a complete stop.
22. **REMOVE ALL MAINTENANCE TOOLS** from the immediate area prior to turning the machine ON.
23. **SECURE** all work. When it is possible, use clamps or jigs to secure the workpiece. This is safer than attempting to hold the workpiece with your hands.
24. **STAY ALERT**, watch what you are doing, and use common sense when operating any machine. **DO NOT** operate any machine tool while tired or under the influence of drugs, alcohol, or medication. A moment of inattention while operating power tools may result in serious personal injury.

25. **USE ONLY** recommended accessories. Use of incorrect or improper accessories could cause serious injury to the operator and cause damage to the machine. If in doubt, **DO NOT** use it.
26. **THE USE** of extension cords is not recommended for 230V equipment. It is better to arrange the placement of your equipment and the installed wiring to eliminate the need for an extension cord. If an extension cord is necessary, refer to the chart in the Grounding Instructions section to determine the minimum gauge for the extension cord. The extension cord must also contain a ground wire and plug pin.
27. Wear proper clothing, **DO NOT** wear loose clothing, gloves, neckties, or jewelry. These items can get caught in the machine during operations and pull the operator into the moving parts. Users must wear a protective cover on their hair, if the hair is long, to prevent it from contacting any moving parts.
28. **SAVE** these instructions and refer to them frequently and use them to instruct other users.
29. Information regarding the safe and proper operation of this tool is also available from the following sources:

Power Tool Institute
 1300 Summer Avenue
 Cleveland, OH 44115-2851
www.powertoolinstitute.org

National Safety Council
 1121 Spring Lake Drive
 Itasca, IL 60143-3201

American National Standards Institute
 25 West 43rd Street, 4th floor
 New York, NY 10036
www.ansi.org

ANSI 01.1 Safety Requirements for
 Woodworking Machines, and the U.S. Department
 of Labor regulations
www.osha.gov

PRODUCT SAFETY

1. Serious personal injury may occur if normal safety precautions are overlooked or ignored. Accidents are frequently caused by lack of familiarity or failure to pay attention. Obtain advice from supervisor, instructor, or another qualified individual who is familiar with this machine and its operations.
2. Every work area is different. Always consider safety first, as it applies to your work area. Use this machine with respect and caution. Failure to do so could result in serious personal injury and damage to the machine.

3. Prevent electrical shock. Follow all electrical and safety codes, including the National Electrical Code (NEC) and the Occupational Safety and Health Regulations (OSHA). All electrical connections and wiring should be made by qualified personnel only.

WARNING

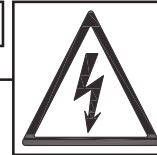

4. **TO REDUCE** the risk of electrical shock. **DO NOT** use this machine outdoors. **DO NOT** expose to rain or moisture. Store indoors in a dry area.

5. **STOP** using this machine, if at any time you experience difficulties in performing any operation. Contact your supervisor, instructor or machine service center immediately.
6. Safety decals are on this machine to warn and direct you to how to protect yourself or visitors from personal injury. These decals **MUST** be maintained so that they are legible. **REPLACE** decals that are not legible.
7. **DO NOT** leave the unit plugged into the electrical outlet. Unplug the unit from the outlet when not in use and before servicing, performing maintenance tasks, or cleaning.
8. **ALWAYS** turn the power switch "OFF" before unplugging the table saw.

WARNING

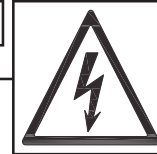

9. **DO NOT** handle the plug or table saw with wet hands.

10. **USE** accessories only recommended by Steel City.
11. **DO NOT** pull the table saw by the power cord. **NEVER** allow the power cord to come in contact with sharp edges, hot surfaces, oil or grease.
12. **DO NOT** unplug the table saw by pulling on the power cord. **ALWAYS** grasp the plug, not the cord.
13. **REPLACE** a damaged cord immediately. **DO NOT** use a damaged cord or plug. If the table saw is not operating properly, or has been damaged, left outdoors or has been in contact with water.
14. **DO NOT** use the table saw as a toy. **DO NOT** use near or around children.

15. **ENSURE** that the machine sits firmly on the floor before using. If the machine wobbles or is unstable, correct the problem by using shims or blocks prior to operation.
16. **KEEP** saw blade sharp and clean. Failure to do so greatly increases friction, decreases cut quality, and increases the possibility of a kickback.
17. **MAKE CERTAIN** the saw blade is parallel with the miter slots and with the rip fence. A blade that is not aligned parallel can cause the workpiece to be pinched between the blade and the fence causing burning or kickbacks.
18. **ALWAYS** use blade guard on all through cuts. This will help prevent the cut from closing on the back of the saw blade. The blade guard also has anti-kickback fingers which minimize the chance of a workpiece being thrown back during a cutting operation.
19. **ALWAYS** push the workpiece past the blade. **DO NOT** release a workpiece until it is past the blade and removed from the saw.
20. **DO NOT** execute a cut when you do not have complete control of the situation.
21. **DO NOT** cut a workpiece that is too large for you to handle.
22. **DO NOT** use the rip fence as a guide when cross-cutting.
23. **BE MINDFUL** of flaws in the wood. Cutting a warped or twisted board along the rip fence can get pinched between the fence and the blade, causing a kickback.
24. **ALWAYS** remove cut off pieces and scraps from the table before starting the saw.
25. **NEVER** start the machine with the workpiece against the blade.
26. **NEVER** perform freehand operations. Use either the fence or miter gauge to position and guide the workpiece through the blade.
27. **ALWAYS** use a pushstick for ripping narrow workpieces.
28. **NEVER** have any part of your body in line with the path of the saw blade. If a kickback occurs with you directly in front of the blade, a serious injury can occur.
29. **NEVER** attempt to free a stalled blade without first turning the machine off and disconnecting the saw from the power source.

ELECTRICAL REQUIREMENTS

WARNING

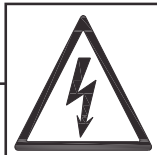

To reduce the risk of electric shock, follow all electrical and safety codes, including the National Electric Code (NEC) and the Occupational Safety and Health Regulations (OSHA). All electrical connections and wiring should be made by qualified personnel only.

The switch provided with your saw is a dual voltage capable switch, meaning it is designed to function at either 120 or 240 volts. The switch and saw comes prewired for 120 volt operation. If you decide to convert the saw to 240V, you will have to replace the 120 volt plug on the switch with a UL/CSA Listed plug, suitable for 240 volts.

The table saw with a 240 volt plug should only be connected to an outlet having the same configuration of your 240V outlet. Please follow the instruction of wiring diagram for changing the motor Voltage from 120 Volt to 240 Volt.

WIRING DIAGRAM

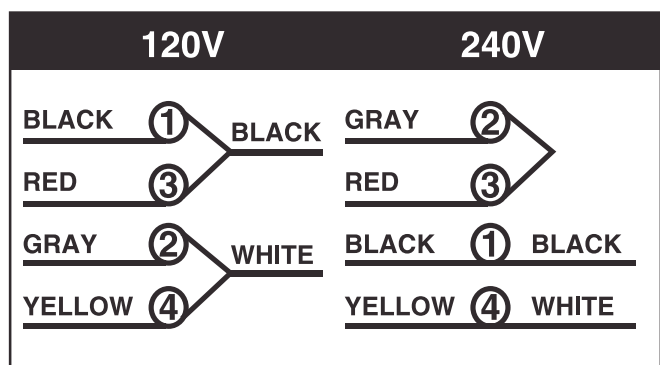

GROUNDING INSTRUCTIONS

⚠ WARNING

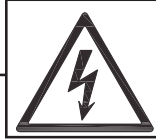

This machine **MUST BE GROUNDED** while in use to protect the operator from electric shock.

In the event of a malfunction or breakdown, **GROUNDING** provides the path of least resistance for electric current and reduces the risk of electric shock. The plug **MUST** be plugged into a matching electrical receptacle that is properly installed and grounded in accordance with **ALL** local codes and ordinances.

If a plug is provided with your machine **DO NOT** modify the plug. If it will not fit your electrical receptacle, have a qualified electrician install the proper connections to meet all electrical codes local and state. All connections must also adhere to all of OSHA mandates.

IMPROPER ELECTRICAL CONNECTION of the equipment-grounding conductor can result in risk of electric shock. The conductor with the green insulation (with or without yellow stripes) is the equipment-grounding conductor. **DO NOT** connect the equipment-grounding conductor to a live terminal if repair or replacement of the electric cord or plug is necessary.

Check with a qualified electrician or service personnel if you do not completely understand the grounding instructions, or if you are not sure the tool is properly grounded.

PLUGS/RECEPTACLES

⚠ WARNING



- Electrocution or fire could result if this machine is not grounded properly or if the electrical configuration does not comply with local and state electrical codes.
- **MAKE CERTAIN** the machine is disconnected from power source before starting any electrical work.
- **MAKE SURE** the circuit breaker does not exceed the rating of the plug and receptacle.

The motor supplied with your machine is either a 115/230 dual voltage motor or a dedicated 230 volt, single phase motor. Never connect the green or ground wire to a live terminal.

The machine should only be connected to an outlet having the same configuration as the plug.

EXTENSION CORDS

⚠ WARNING

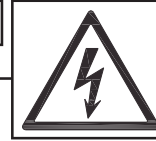

To reduce the risk of fire or electrical shock, use the proper gauge of extension cord. When using an extension cord, be sure to use one heavy enough to carry the current your machine will draw.

The smaller the gauge-number, the larger the diameter of the extension cord is. If in doubt of the proper size of an extension cord, use a shorter and thicker cord. An undersized cord will cause a drop in line voltage resulting in a loss of power and overheating.

⚠ CAUTION

USE ONLY a 3-wire extension cord that has a 3-prong grounding plug and a 3-pole receptacle that accepts the machine's plug.

If you are using an extension cord outdoors, be sure it is marked with the suffix "W-A" ("W" in Canada) to indicate that it is acceptable for outdoor use.

Make certain the extension cord is properly sized, and in good electrical condition. Always replace a worn or damaged extension cord immediately or have it repaired by a qualified person before using it.

Protect your extension cords from sharp objects, excessive heat, and damp or wet areas.

MINIMUM RECOMMENDED GAUGE FOR EXTENSION CORDS (AWG)

120 VOLT OPERATION ONLY			
	25' LONG	50' LONG	100' LONG
0 to 6 Amps	18 AWG	16 AWG	16 AWG
6 to 10 Amps	18 AWG	16 AWG	14 AWG
10 to 12 Amps	16 AWG	16 AWG	14 AWG
12 to 15 Amps	14 AWG	12 AWG	Not recommended

MINIMUM RECOMMENDED GAUGE FOR EXTENSION CORDS (AWG)

240 VOLT OPERATION ONLY			
	25' LONG	50' LONG	100' LONG
0 to 6 Amps	18 AWG	18 AWG	16 AWG
6 to 10 Amps	18 AWG	18 AWG	14 AWG
10 to 12 Amps	16 AWG	16 AWG	14 AWG
12 to 15 Amps	14 AWG	12 AWG	Not recommended

UNPACKING & INVENTORY

⚠ WARNING

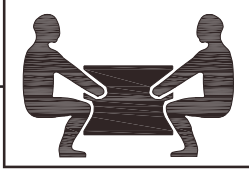

- The machine is heavy, two people are required to unpack and lift.
- Use a safety strap to avoid tip over when lifting machine.

Check shipping carton and machine for damage before unpacking. Carefully remove packaging materials, parts and machine from shipping carton. Always check for and remove protective shipping materials around motors and moving parts. Lay out all parts on a clean work surface.

Remove any protective materials and coatings from all of the parts and the table saw. The protective coatings can be removed by spraying WD-40 on them and wiping it off with a soft cloth. This may need redone several times before all of the protective coatings are removed completely.

After cleaning, apply a good quality paste wax to any unpainted surfaces. Make sure to buff out the wax before assembly.

Compare the items to inventory figures; verify that all items are accounted for before discarding the shipping box.

⚠ WARNING

If any parts are missing, do not attempt to plug in the power cord and turn "ON" the machine. The machine should only be turned "ON" after all the parts have been obtained and installed correctly. For missing parts, contact Steel City at 1-877-SC4-TOOL.

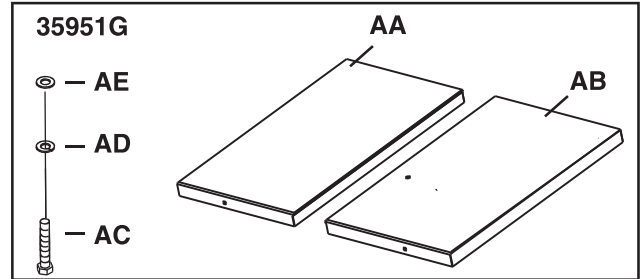

- AA)** LEFT GRANITE EXTENSION WING
- AB)** RIGHT GRANITE EXTENSION WING
- AC)** 5/16-18X50mm HEX BOLT (8)
- AD)** M8 LOCK WASHER (8)
- AE)** M8 SPECIAL WASHER (8)

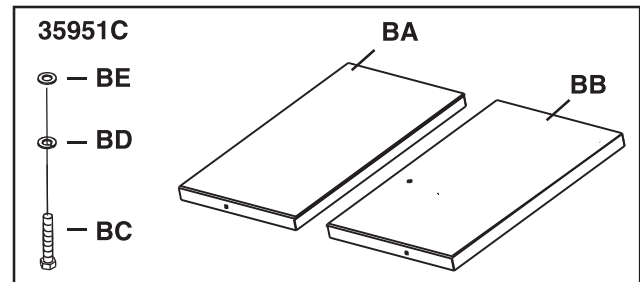

- BA)** LEFT CAST IRON EXTENSION WING
- BB)** RIGHT CAST IRON EXTENSION WING
- BC)** 5/16-18X50mm HEX BOLT (8)
- BD)** M8 LOCK WASHER (8)
- BE)** M8 SPECIAL WASHER (8)

Bag 1. Extension Wing Screw Package

- A) M8 FLAT WASHER OR91084 (8)
- B) M8 LOCK WASHER OR90248 (8)
- C) 5/16-18X50mm HEX BOLT SC80470 (8)



Location

Bag 2. Fence Bracket Package

- A) M4 X 8mm ROUND HD TAP SCREW OR91832 (2)
- B) WRENCH HOOK OR91134 (1)
- C) FENCE BRACKET OR91135 (2)
- D) 1/4 - 20 x 3/8" ROUND HD TAP SCREW OR91787 (4)

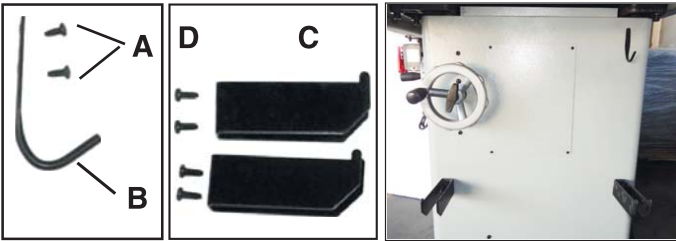

Location

Bag 3. Switch Screw Package

- G) M6 FLAT WASHER OR90059 (2)
- H) M6 LOCK WASHER OR90502 (2)
- I) M6X16 PAN HEAD SCREW SC80111 (2)



Location

Bag 4 Dust Chute / Port Screw Package

- A) 1/4-20 X 1/2 ROUND HD TAP SCREW SC80408 (4)

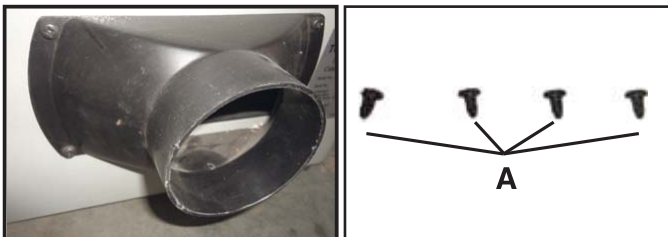

Location

Bag 5. Caster Wheel Screw Package

- A) M8X16 CARRIAGE BOLT OR94470 (2)
- B) M8 HEX FLANGE NUT OR94771 (2)
- C) LEVELING SCREW SC10529 (2)
- D) M8 HEX NUT OR90307 (2)
- E) CASTER WHEEL ASSY SC90010 (1)
- F) M8 x 50mm SCR-HEX HD OR91497 (2)
- G) M8 WASHER FLAT OR90311 (2)
- H) WHEEL OR91505 (2)

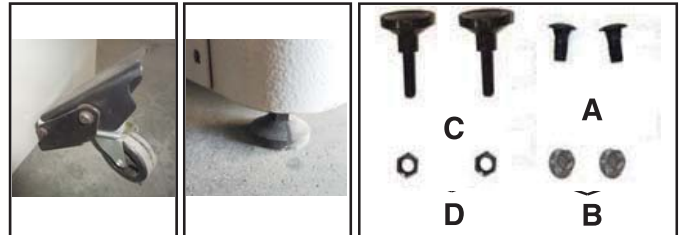

Location

Location

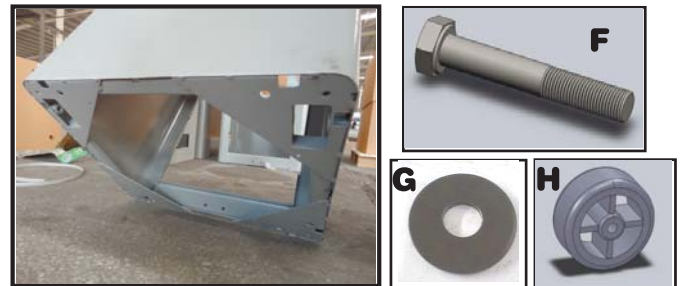

Location

Bag 6. Spacer Package

- A) SPACER SC76074 (2)

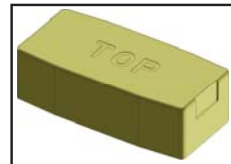

OTHERS

- A) Blade Guard & Splitter Assembly
- B) On/Off Switch
- C) Miter Gauge
- D) Blade Wrench
- E) Blade Wrench
- F) Handwheel Assembly
- G) Handwheel Knob
- H) Caster Wheel

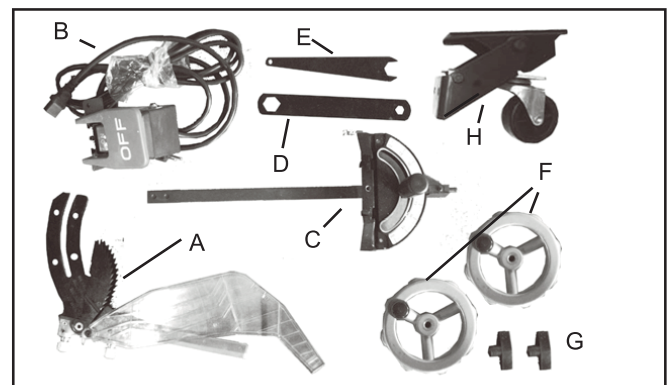

ASSEMBLY

⚠ WARNING

- The table saw is a heavy machine; two people may be required for certain assembly operations.
- **DO NOT** assemble the table saw until you are sure the tool is unplugged.
- **DO NOT** assemble the table saw until you are sure the power switch is in the “OFF” position.
- For your own safety, **DO NOT** connect the machine to the power source until the machine is completely assembled and you read and understand this entire User Manual.

WHEEL KIT ASSEMBLY

⚠ WARNING

MAKE CERTAIN THAT THE SAW IS DISCONNECTED FROM THE POWER SOURCE.

NOTE: Use **FIG. 1** as a referencing guide.

1. Acquire something sturdy to maintain the weight of the saw.
2. Lay the saw on back. **CAUTION:** The table saw is heavy; two people are required for this operation. Be sure to lay cardboard on the floor to protect the table and cabinet. Use wedge to have an angle. Approximate 40°~45°.

CAUTION: DO NOT LET EDGE OF GRANITE CONTACT FLOOR, IT MAY CHIP.

Fig. 1



3. Install the adjust feet (Key #422/422a) and install the straight wheel (Key #433, #434, and #435).
4. Tighten all the screws.
5. Flip wheel assembly that includes Key #436~443. Carriage bolts are Key #444.
6. Attach the Flip Wheel to the opposite side by using Carriage bolts (2) and Lock Nuts (2). Tighten them in position.
7. With help, raise the saw to leveling position.

HANDWHEEL ASSEMBLY

⚠ WARNING

MAKE CERTAIN THAT THE SAW IS DISCONNECTED FROM THE POWER SOURCE.

Fig. 3

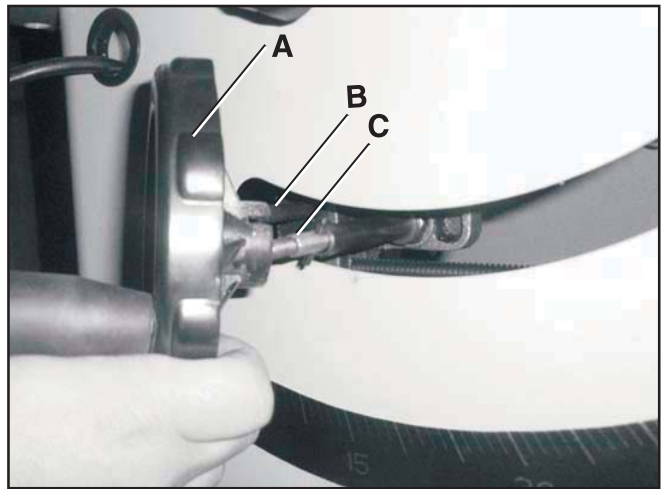

1. Place one of the handwheels (A) onto the blade raise / lower shaft (B) located on the front of the cabinet. Align the groove in the back of the handwheel with the pin (C). SEE FIG. 3

Fig. 4

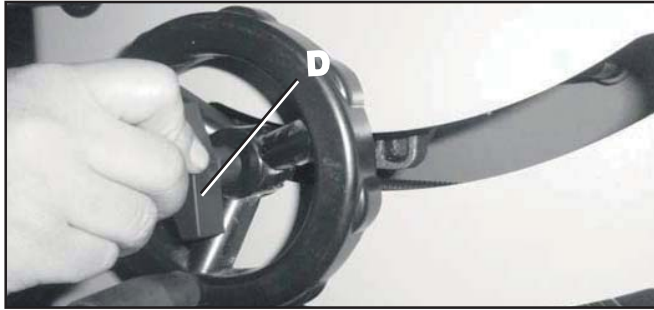

2. Thread the locking knob (D) onto the threaded end of the shaft. **SEE FIG. 4**

Repeat the steps above to assemble the remaining handwheel and locking knob onto the bevel shaft located on the side of the cabinet.

WRENCH AND FENCE HOOK ASSEMBLY

⚠ WARNING

MAKE CERTAIN THAT THE SAW IS DISCONNECTED FROM THE POWER SOURCE.

Fig. 5

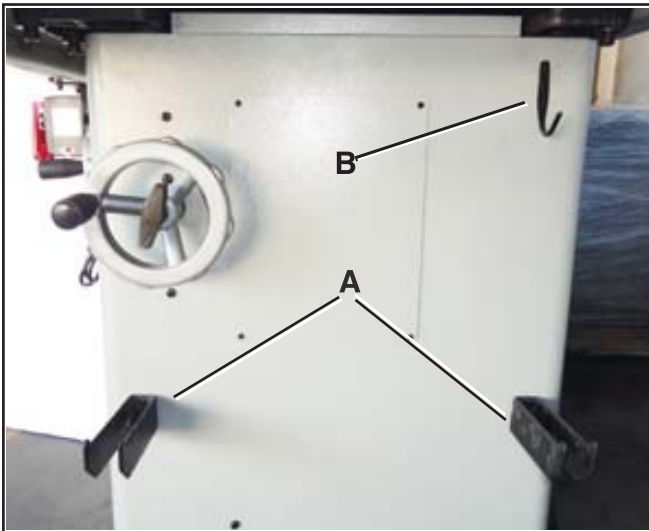

1. Assemble both of the fence hooks (A) to the left and right cabinet using two M4 X 8mm tap screw.
2. Assemble wrench hook (B) to the right side of cabinet using two 2-1/4" tap screws. **SEE FIG.5**

EXTENSION WING ASSEMBLY FOR 35951G & 35951C

⚠ WARNING

MAKE CERTAIN THAT THE SAW IS DISCONNECTED FROM THE POWER SOURCE.

CAUTION: The extension wings are heavy; two people are required to assemble both extension wings to the table saw. The installation method for granite and cast iron wing is the same.

1. One person put right/ left extension wing on the top of cabinet. Match the alignment pin (A) to the holes on the bottom of the wing. **SEE FIG. 6**

Fig. 6

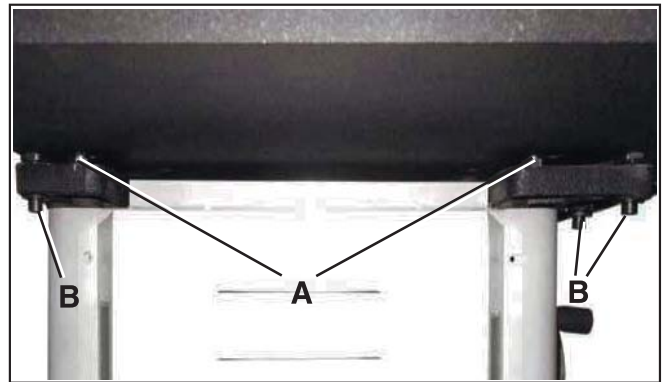

2. The other person installs 50mm Shoulder bolts (4), (B) with Flat and Spring Washers from the bottom of the cabinet. Do not fully tighten. Then use the provided spacer, fit into the mitre slots to achieve proper width for the mitre guage. Tighten the Shoulder Screws in place and remove the mitre slot spacer.

NOTE: The Pre-adjustment and Pre-setting of the extension wings for the flatness has been completed in Factory.

3. To adjust wings, if needed, loosen the set screws by 2.5mm Allen Wrench at (C) location **SEE FIG. 7**

Fig. 7

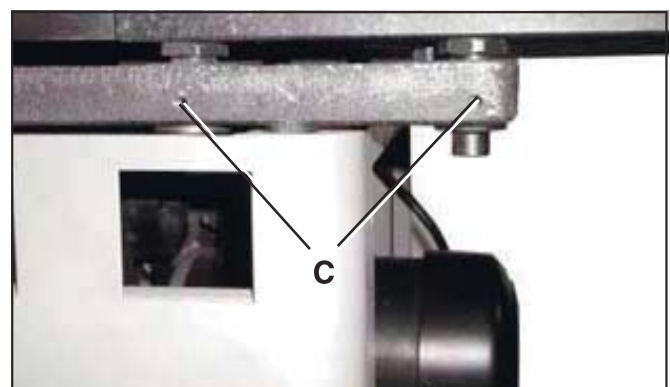

4. Use blade wrench to adjust the hollow bolt (B).
SEE FIG. 8

Fig. 8

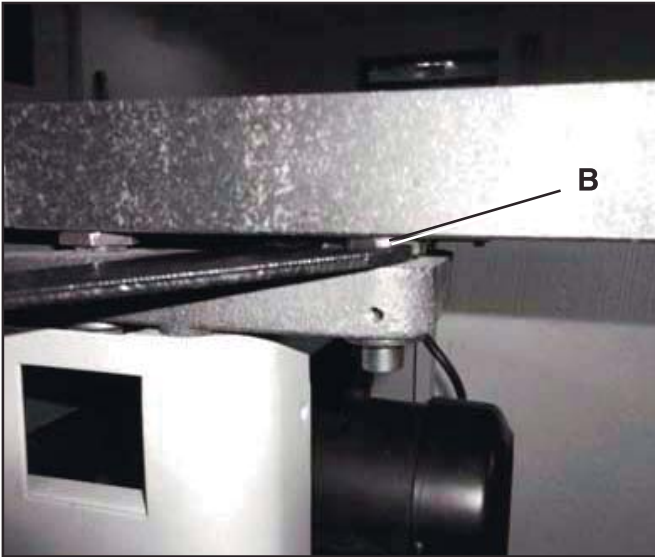

5. Tightening the set screws (C).**SEE FIG. 7**
6. Use a straight edge across to the main table and extension wings, checking the flatness on all assembled.**SEE FIG. 9**

Fig. 9

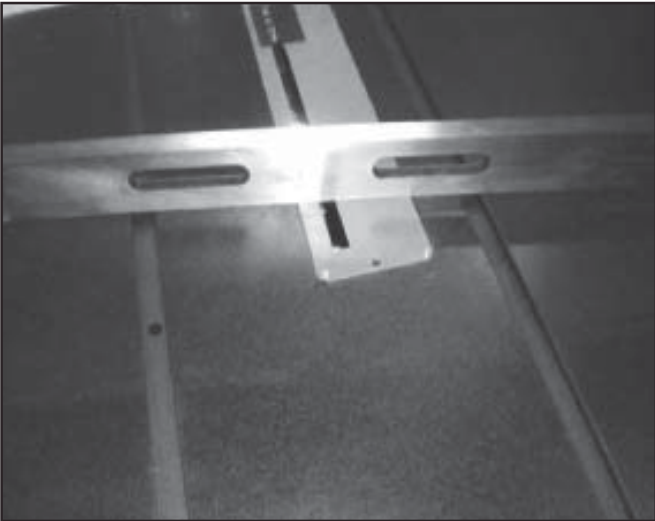

7. If the wings are not leveled, please repeat Step 3 to 5.

CONNECTING SWITCH CORD TO MOTOR CORD

⚠ WARNING

MAKE CERTAIN THAT THE SAW IS DISCONNECTED FROM THE POWER SOURCE.

1. Place the switch cord (A) through hole (B) in front of Cabinet. **SEE FIG. 18**
2. Open motor cover, insert three prong switch cord (C) into three hole outlet (D) of the motor cord. **SEE FIG. 19**

Fig. 18

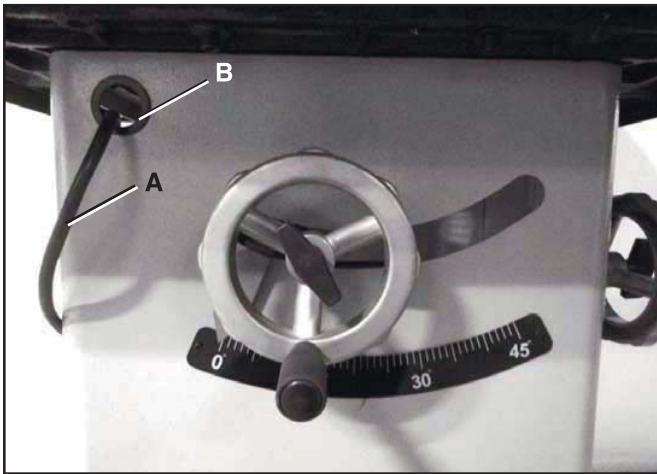

3. Pull slack in switch cord into the cabinet. Make sure that the power cord inside of the cabinet is properly routed and clear of the saw blade and any pinch points for all blade height and blade angle settings.

Fig. 19

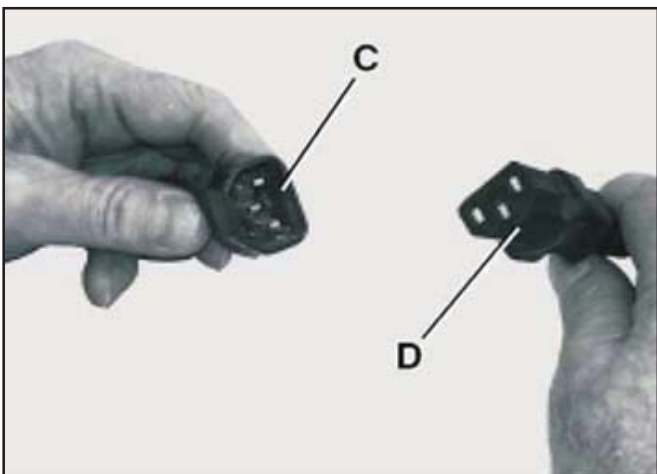

INSTALLATION AND LEVELING

Final location for the saw must be level, dry, well lighted, and have enough room to allow movement around the saw with long pieces of wood stock.

Level the saw front to back and side to side, using a carpenter's level placed on the table. Use shims under the corners, if necessary, but make sure the saw is stable before being placed into service.

RIVING KNIFE / SPLITTER COMPONENTS ASSEMBLY

⚠ WARNING

MAKE CERTAIN THAT THE SAW IS DISCONNECTED FROM THE POWER SOURCE.

NOTE: Remove the table insert (Table insert are gripped by four magnets on the table).

Fig. 20

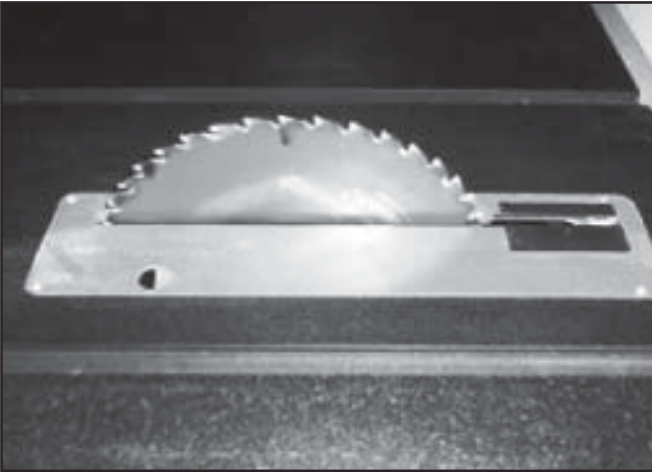

INSTALLING AND REMOVING THE RIVING KNIFE / SPLITTER

The factory will install the blade & splitter at factory to ensure they are in alignment.

To Install:

1. Loosen the knob by pulling upwards (C), Line up the riving knife/splitter in the proper direction to the mounting bracket (B).
SEE FIG. 21
2. Push the Riving Knife/ Splitter all the way down into the mounting bracket, make sure the location pin is properly locked in the hole of the Riving Knife/ Splitter. (The location hole is on the button side of the Riving Knife/ Splitter).
3. Lock the splitter by lowering arm towards front.
SEE FIG. 22

To Remove:

1. Loosen the fasten knob (C).**SEE FIG. 22**
2. Remove the Riving Knife/ splitter out of mounting bracket (B).**SEE FIG. 22**

NOTE: Make sure blade or arbor is at the highest position before adding or removing the riving Knife/ Splitter.

Fig. 22

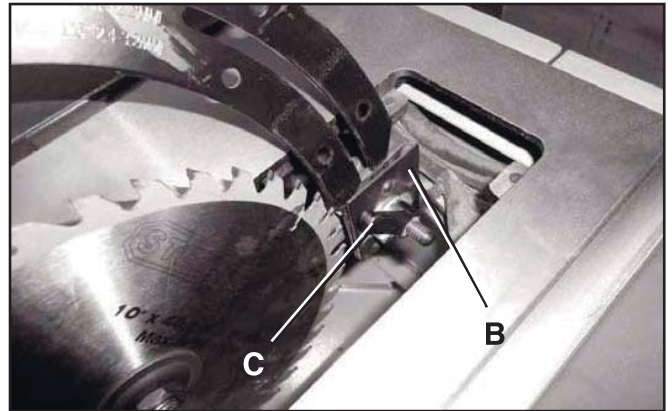
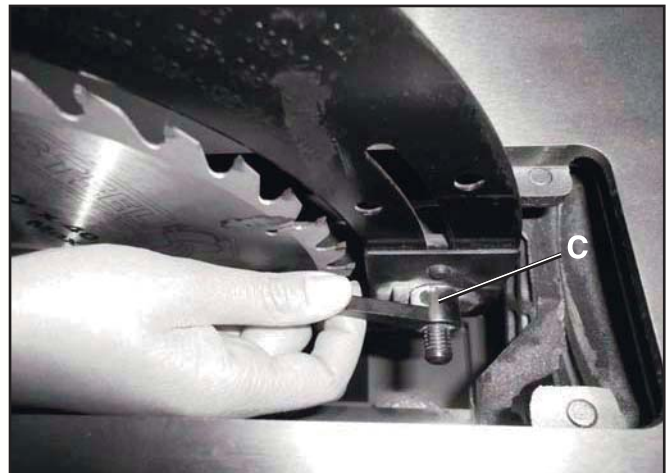

Fig. 22



BLADE ASSEMBLY

⚠ WARNING

MAKE CERTAIN THAT THE SAW IS DISCONNECTED FROM THE POWER SOURCE.

Fig. 23

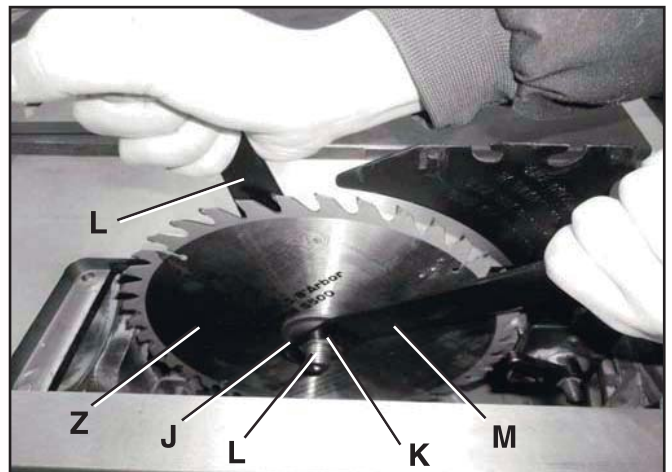

1. Remove the hex nut (K) and outer flange (J) from the blade arbor (I).

NOTE: The arbor has a right hand thread; to loosen the hex nut turn it counterclockwise by using the supplied wrenches.

2. Place a 10" saw blade (Z) onto the blade arbor (I), make sure the teeth of the blade are pointing down in the front of the table saw. Place the outer flange (J) and hex nut (K) onto the blade arbor and snug hex nut by hand. Place the open-end blade wrench (L) on the flats of the inner blade flange (not shown) and the box-end blade wrench (M) onto the hex nut and securely tighten. **SEE FIG. 23**

NOTE: The blade arbor has a right hand thread, to tighten the hex nut turn it clockwise.

Fig. 24



3. Place a square (N) onto the saw blade and against the splitter assembly (O). Make sure the splitter is square to table. **SEE FIG.24**

4. Lay a straight edge (R) against the left side of the saw blade (S) Align the splitter and make sure the splitter is aligned to the blade. **SEE FIG.25**

Fig. 25

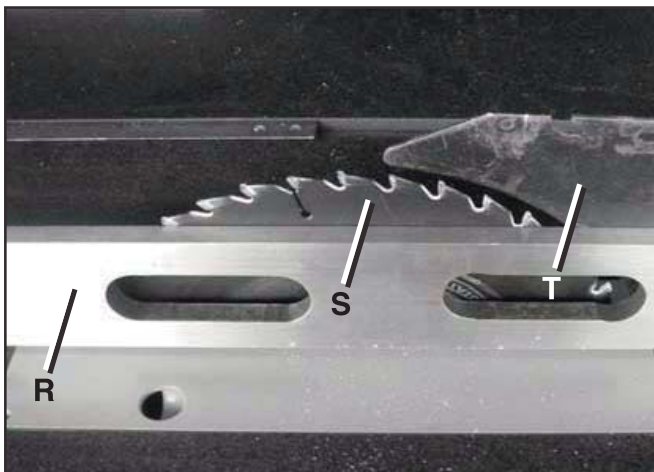

CONVERSION THE SPLITTER TO RIVING KNIFE

⚠ WARNING

MAKE CERTAIN THAT THE SAW IS DISCONNECTED FROM THE POWER SOURCE.

NOTE: Splitter can be used as riving knife.

1. Remove the guard assembly (C) and kick-back pawl assembly (D) by loosening knob (A) and (B). **SEE FIG. 26**

Fig. 26

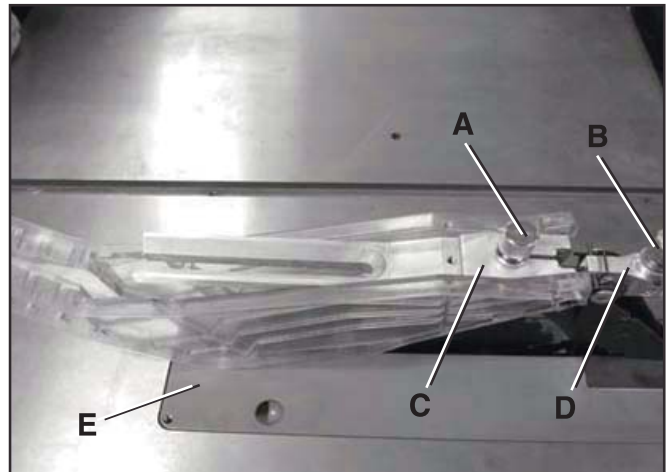

2. Remove the table insert (E). **SEE FIG. 26**

Fig. 27

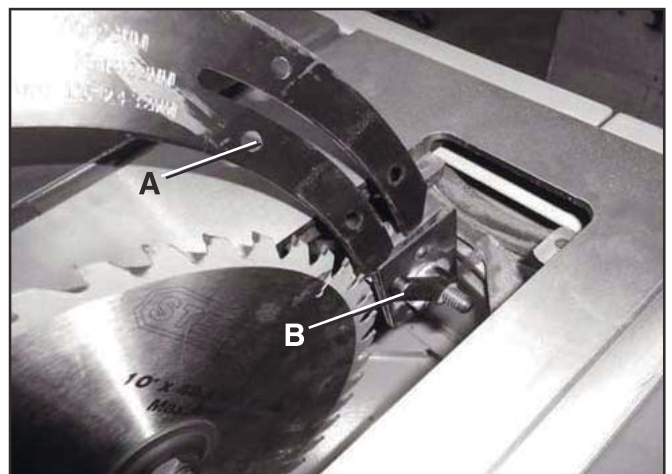

3. Loosen locking arm (B), move splitter to lower position by tilting blade slightly to right. Align pins to holes (A). **SEE FIG. 27**

4. Tighten the Arm (B) and re-install the table insert. **SEE FIG. 27**

ADJUSTMENTS

RAISING AND LOWERING THE BLADE

Fig. 28

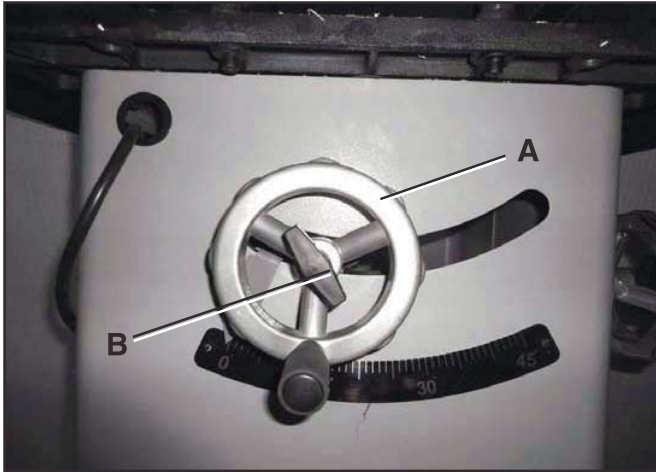

The blade height adjustment handwheel and handwheel lock knob are located on the front of the cabinet above the blade bevel scale. To raise the saw blade, loosen the handwheel lock knob (B) (counterclockwise) and turn the handwheel (A) clockwise. When the saw blade is at its desired height, tighten the handwheel lock knob (clockwise) until it is securely tightened.

To lower the saw blade, loosen the handwheel lock knob (counterclockwise) and turn the handwheel counterclockwise. When the saw blade is at its desired height, tighten the handwheel lock knob (clockwise) until it is securely tightened. **SEE FIG. 28**

TILTING THE BLADE

The blade bevel handwheel and handwheel lock knob are located on the right side of the cabinet. To increase the saw blade bevel, loosen the adjustment knob (C) and then turn the hand wheel clockwise. When the saw blade is at its desired degree, tighten the adjustment knob (clockwise) (C). **SEE FIG. 28A**

Fig. 28A

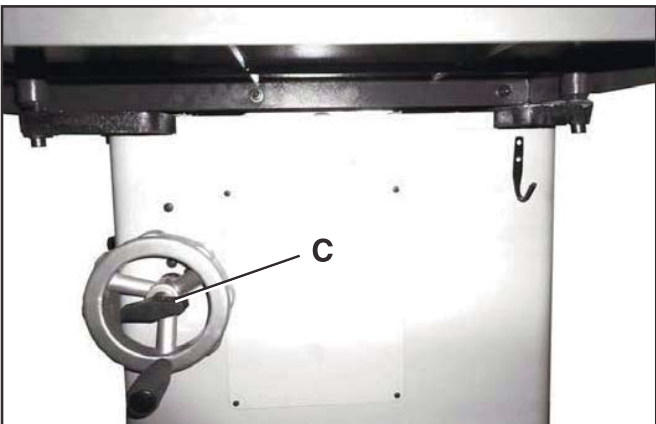

ADJUSTING BLADE BEVEL POSITIVE STOP

Fig. 29



1. To adjust blade to a 90-degree blade bevel positive stop, raise the saw blade (A) to its highest position. **SEE FIG. 29**
2. Using a combination square (B) check that the blade is 90 degrees to the saw table (zero degrees on bevel Scale).
3. If the blade will not tilt to 90 degrees, when the set screw contacts the stop position, and turn it until the blade can be positioned to 90 degrees. **SEE FIG. 30 (C)**
4. Once the blade has been tilted to 90 degrees (confirm this using your square), tighten the adjustment handle, located on the front of the cabinet. This will keep the blade from tilting further. **SEE FIG. 30 (C)**
5. If the blade will not tilt to 45 degrees, when the set screw (D) contacts the stop position and turn it until the blade can be positioned to 45 degrees. **SEE FIG. 30**

Fig. 30

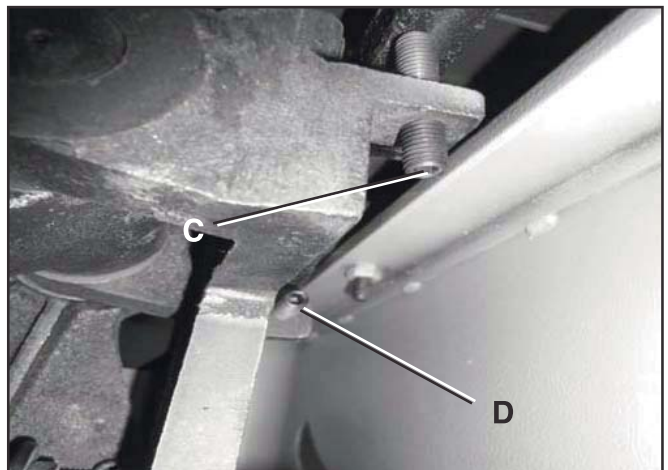
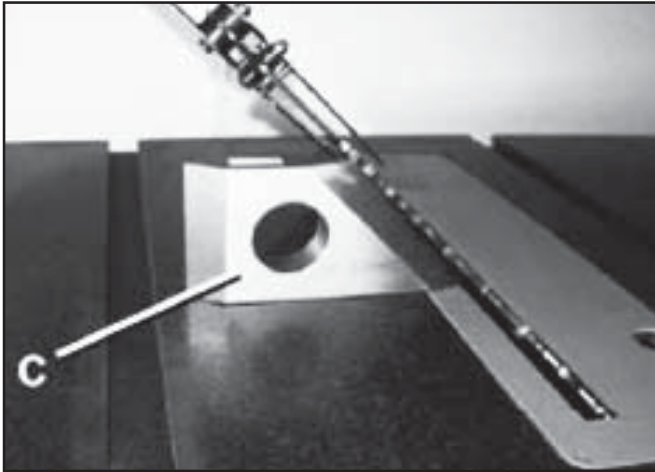

Fig. 31



6. Using a combination square (C), make sure that the blade is at 45 degrees. **SEE FIG. 31**
7. With the blade at 45 degrees, tighten the adjustment handle to keep the blade from further tilting. **SEE FIG. 30 (D)**
8. Turn the set screw clockwise until it comes in contact with the positive stop (D). **SEE FIG. 30**

CHECKING BLADE ALIGNMENT

Blade heel is the misalignment of the blade to the miter slots. This means that the blade is not parallel to the miter slots. The blade is set parallel at the factory and should not need any adjustments. You can check this by using a dial indicator (not included) or a combination square (not included). It is recommended to check the alignment before initial operation as follows:

⚠ WARNING

MAKE CERTAIN THAT THE SAW IS DISCONNECTED FROM THE POWER SOURCE.

Fig. 32

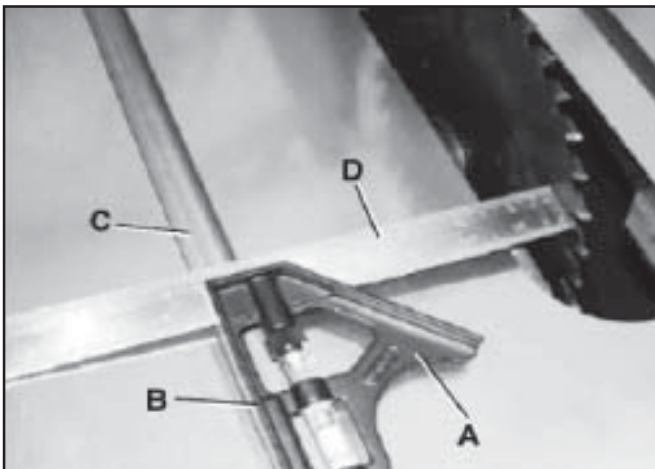

1. Raise the saw blade to its highest point.

2. Place a combination square (A) on the saw table with one edge (B) of the square against the left miter slot (C). **SEE FIG. 32**
3. Adjust the square so the rule (D) just touches the saw blade. Make sure the rule is not touching any of the carbide tips of the saw blade.
4. Lock the rule in this position.

Fig. 33

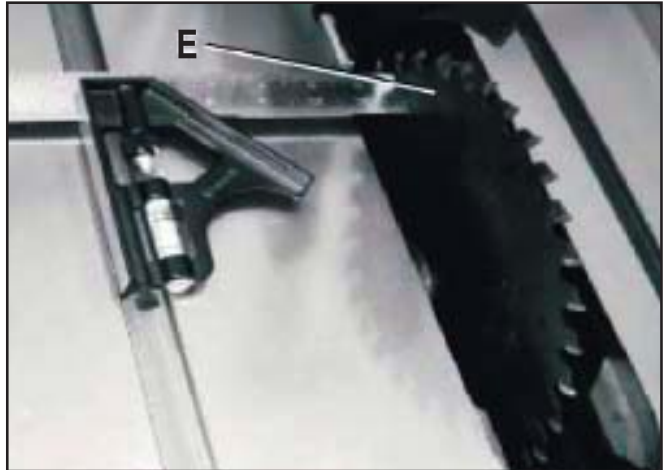

6. Rotate the saw blade back so that you take the measurement from the same spot on the saw blade. **SEE FIG. 33**
7. Take a reading at the rear of the blade (E) with the combination square. If there is a difference of more than .01 in between the rule and the blade, then an adjustment will have to be made.

ADJUSTING BLADE ALIGNMENT

NOTICE: Blade alignment is factory set and should not need adjustment. All saw blades have some runout. Therefore, readjusting the blade alignment should only be attempted if it becomes necessary (see "CHECKING BLADE ALIGNMENT")

⚠ WARNING

MAKE CERTAIN THAT THE SAW IS DISCONNECTED FROM THE POWER SOURCE.

1. To align the blade parallel to the miter slot, first loosen two hex soc head screws (A) under the front side of the table saw. This is the same side as the raise/lower handwheel (B). **SEE FIG. 34**
2. Remove the End cap on the rear side of the table saw, Loosen two hex soc head screws (A). **SEE FIG. 35**
3. The saw table is now loose and can be repositioned until the blade is parallel to the miter slot. Repeat steps in "CHECKING BLADE ALIGNMENT."

Fig. 34

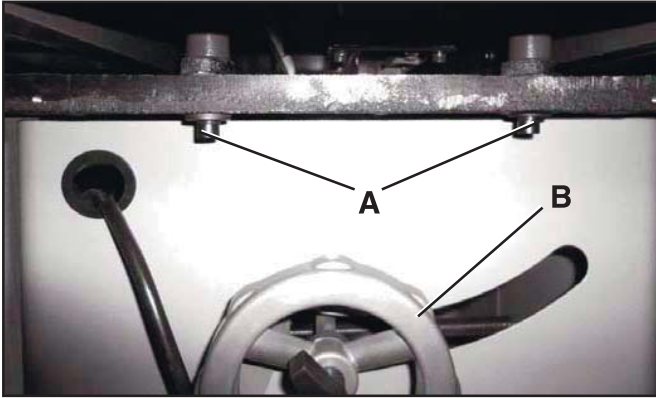
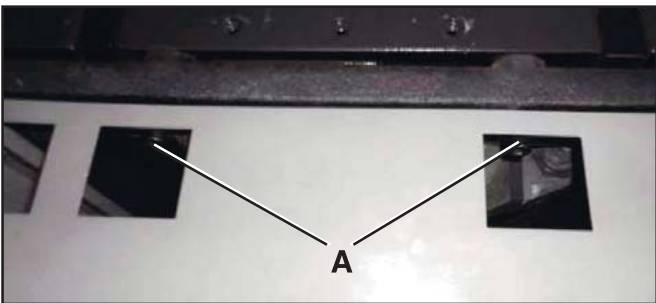

Fig. 35



4. When blade is parallel to miter slot, tighten all four hex soc head screws.
5. Recheck blade alignment.
6. Tilt the blade to 45 degrees, and rotate the saw blade by hand. Make sure the blade does not contact the table insert.

BEVEL ARROW ADJUSTMENT

1. Make certain that the blade is at 90-degrees to the table surface with a combination square.
2. Check that the bevel arrow is pointing to the zero degree mark on the bevel scale located on the front of the cabinet.
3. To adjust arrow, loosen the Phillips head screw (A), and reposition the bevel arrow and tighten screw.

Fig. 36

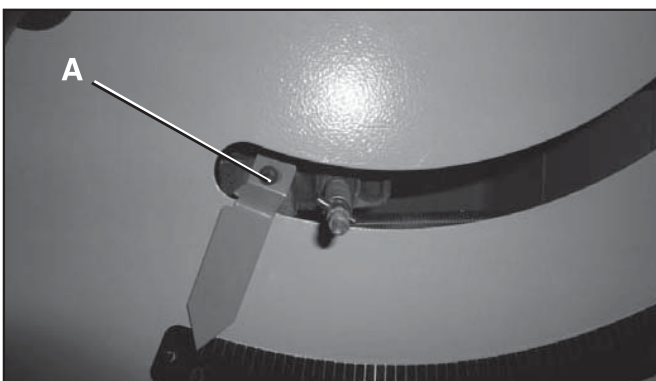

POLY-V BELT ASSEMBLY

1. Loosen 6 of M5x10mm cross pan head tap screws (A) and remove the cabinet access door **SEE FIG. 37**

Fig. 37



2. Install the belt on the Arbor Pulley and raise motor by loosening 1 of the motor mounting bolts (B) and nuts (C) to reach the belt distance for assembling the belt on the motor Pulley. **SEE FIG. 38 & FIG. 39**

Fig. 38

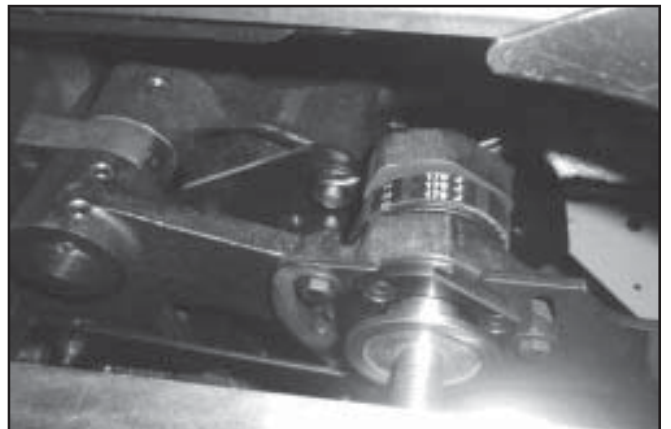
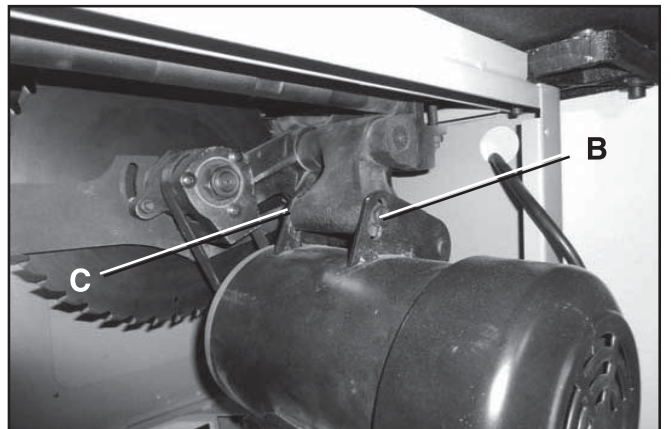

Fig. 39



3. Replace the cabinet access door.

TABLE INSERT ADJUSTMENT

⚠ WARNING

MAKE CERTAIN THAT THE SAW IS DISCONNECTED FROM THE POWER SOURCE.

Fig. 40

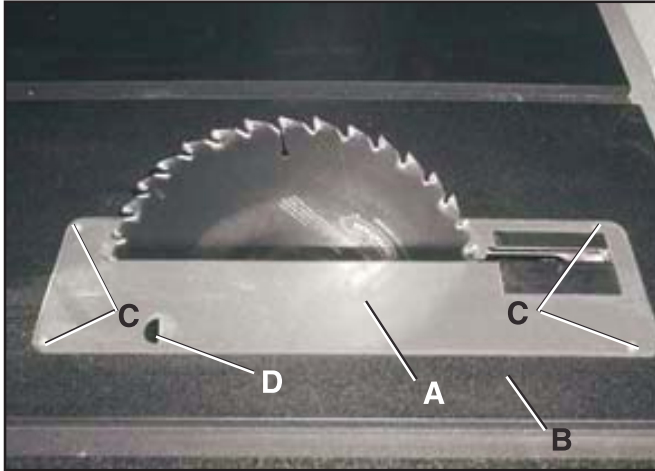

1. The table insert (A) must always be level with the saw table (B).
2. Place a straight edge across the front and rear of the table insert. Check that the insert is perfectly level with the saw table.
3. To level the table insert, turn the one or more adjusting set screws (C) as needed and recheck.
4. The table insert is equipped with a finger hole (D) for easy removal. **SEE FIG. 40**

MITER GAUGE ADJUSTMENT

⚠ WARNING

MAKE CERTAIN THAT THE SAW IS DISCONNECTED FROM THE POWER SOURCE.

Fig. 41

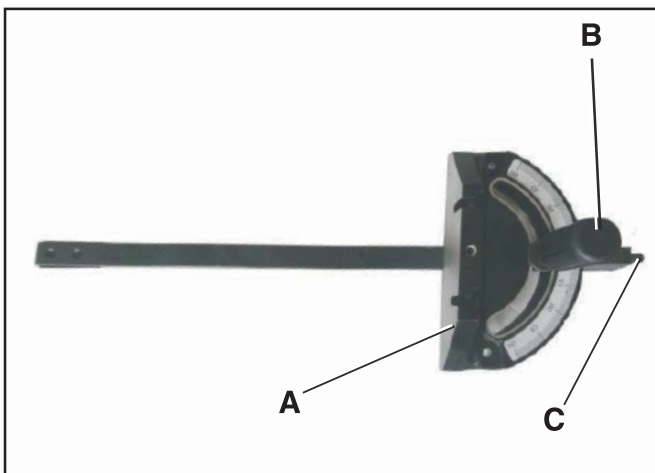

1. The miter gauge has adjustable positive stops at 0-degree and 45-degrees or it can be manually set at any angle between 60-degrees.
2. To rotate miter gauge body (A), loosen knob (B) and pull out plunger (C) and rotate miter gauge body to desired angle and tighten knob.
3. To rotate to the next positive stop, pull plunger (C) out, rotate miter gauge body then push plunger back in and continue rotating miter gauge body until it stops against next positive stop.

ADJUSTING POSITIVE STOPS

Fig. 42

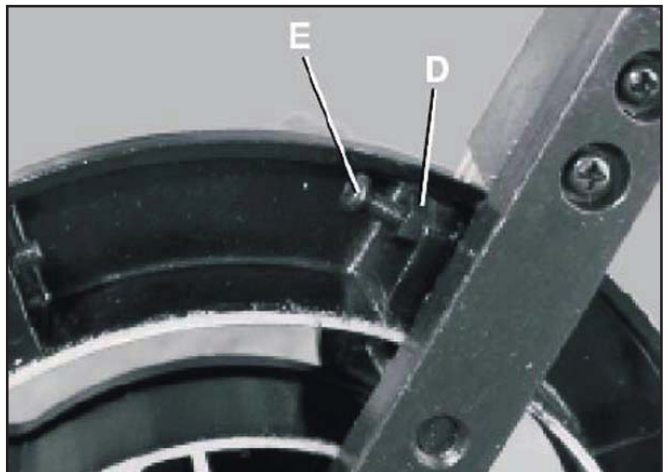

1. To adjust 0-degree positive stops, loosen knob (B), pull out on plunger (C) and turn miter gauge over.
2. Loosen the lock nut (D) 3 or 4 turns **SEE FIG. 42**
3. Place a square against the guide bar and front of the miter gauge body. Square the miter gauge body to the guide bar and tighten knob.
4. Push in plunger and make adjustments to stop screw (E) so that it touches the plunger and tighten lock nut.
5. Recheck the positive stop angle to the saw blade. insert the guide bar into the miter slot and slide the miter gauge up to the saw blade.
6. To check, place a square against the saw blade and miter gauge body. If any more adjustments are needed repeat steps above.
7. To set both 45-degree positive stops, repeat steps 1 thru 6 above at the 45-degree settings.

OPERATIONS

⚠ CAUTION

- A separate electrical circuit should be used for your table saw. The circuit should not be less than #14 AWG wire and should be protected with a 15-amp time lag fuse.
- Have a qualified electrician repair or replace damaged or worn cord immediately.
- Before connecting the motor to the power line, make certain the switch is in the “OFF” position and be sure that the electric current is of the same characteristics as the motor nameplate. All line connections should make good contact.
- Running on low voltage or long extension cords will damage the motor.

⚠ WARNING

- **DO NOT** expose the table saw to rain or operate the in damp locations.
- **MAKE SURE** all parts have been assembled correctly and are in working order.
- **KEEP** table surface clear of tools and debris before starting table saw.

STARTING AND STOPPING THE SAW

Fig. A

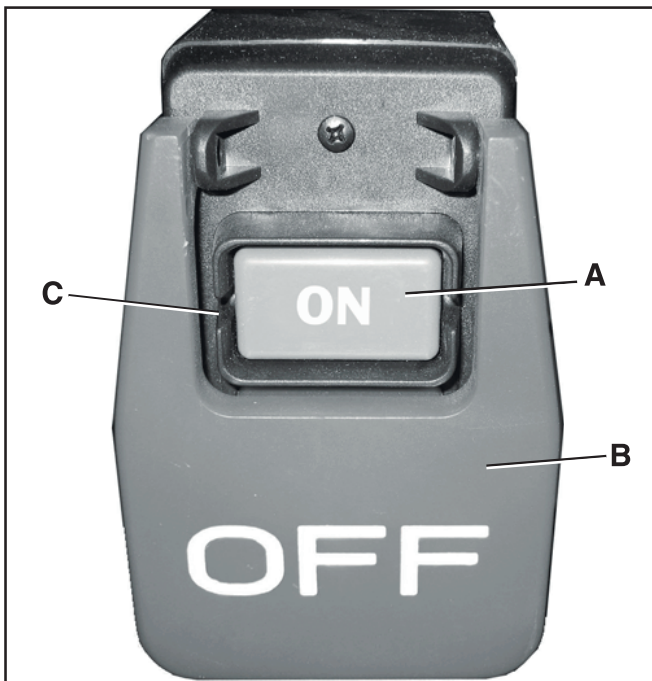

1. The ON/OFF switch is located under the front rail on the table saw.
2. To turn the table saw on, press the green “START” button (A) in one-half inch. Note: There is a safety feature on the switch to insure that the switch must be completely pressed before the saw will START. **SEE FIG. A.**
3. To turn the table saw off, press the large red “OFF” paddle (B) or lift the paddle and press directly on the red “OFF” button.
4. When the table saw is not in use, the “ON” button should be locked so that it cannot be started.
5. Using a padlock (not provided), it is possible to lock the switch to prevent unauthorized use. Lift the red “OFF” paddle and place a padlock through the holes (C) in the side of the “ON” button and then lock the padlock. Make sure keys have been removed from padlock and placed where no children can get them. **SEE FIG. A.**
6. To use the table saw, unlock and remove the padlock from the “ON” button.

THERMAL-OVERLOAD PROTECTION

⚠ WARNING

- Turn the power switch “OFF” and unplug the power cord from its power source prior to doing or performing any maintenance.
- Make certain that the “OFF” button has been depressed before pushing the thermal-overload reset button.

The motor supplied with your table saw has a resettable thermal-overload relay located on the side of the switch. If the motor shuts off during an operation (cutting a workpiece too fast or using a dull blade, using the saw beyond its capacity, or low voltage) press the “OFF” button and let the motor cool three to five minutes. Push the reset thermal-overload button on the side of the ON/OFF switch assembly. Make certain that the saw blade and work area has been cleared of debris before restarting saw. The motor can now be turned on again.

⚠ WARNING

MAKE CERTAIN THAT THE SAW IS DISCONNECTED FROM THE POWER SOURCE.

⚠ WARNING

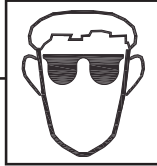

ALWAYS wear eye protection. Any machine can throw debris into the eyes during operations, which could cause severe and permanent eye damage. Everyday eyeglasses are **NOT** safety glasses. **ALWAYS** wear Safety Goggles (that comply with ANSI standard Z87.1) when operating power tools.

⚠ WARNING

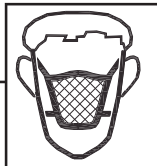

ALWAYS wear a NIOSH/OSHA approved dust mask to prevent inhaling dangerous dust or airborne particles.

NOTICE

The following section was designed to give instructions on the basic operations of this table saw. However, it is in no way comprehensive of every table saw application. It is strongly recommended that you read books, trade magazines, or get formal training to maximize the potential of your table saw and to minimize the risks.

PRE-RUN CHECK

Before you begin to use your Table Saw, you should give it a thorough inspection, making sure you ask yourself the following questions:

1. Is the blade mounted correctly?
2. Is the saw stable?
3. Is it wired properly?
4. Is your electrical system properly configured?
5. Have you checked your workpiece for obvious defects?
6. Is the guard assembly installed and functional?
7. Have you checked the saw blade clearance when it is adjusted to varying angles and depths?
8. Have you read all the warnings and directions regarding the operation of this machine?

TEST RUN

1. Face the table saw and stand to the left of the blade path.
2. With one finger on the ON button and one finger on the OFF button, turn the saw on. Be ready to turn the saw off in case of a mishap.
3. Watch and listen to the saw. Note whether there are any unusual sounds or excessive vibrations.
4. If anything appears abnormal, immediately turn off the saw, unplug it, and fix the problems. If a problem exists that is beyond the scope of this manual, contact your dealer.
5. If the saw is behaving normally, turn it off and prepare to make a cut according to the instructions outlined in this section.

BLADE SELECTION

Choosing the correct blade for the job is essential for the safe and efficient use of your table saw. Ignoring this important step could result in damage to the saw and serious injury to the operator. Below are the most common saw blades and their uses.

1. **Rip Blade:** Used for cutting with the grain. Typically, 10" rip blades have between 18-40 teeth and large gullets to allow for large chip removal. SEE FIG. 31.

Fig. 31

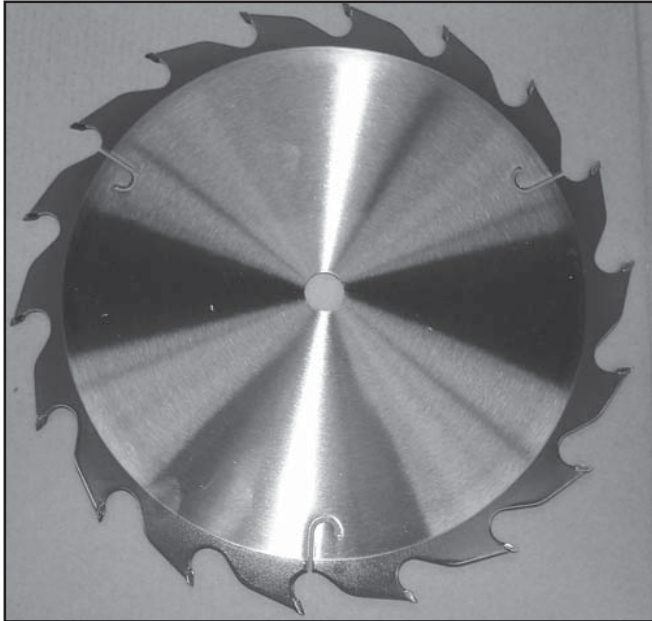

2. **Cross-cut Blade:** Used for cutting across the grain. 10" cross-cut blades have between 60-80 teeth and a shallow gullet. SEE FIG. 32.

Fig. 32

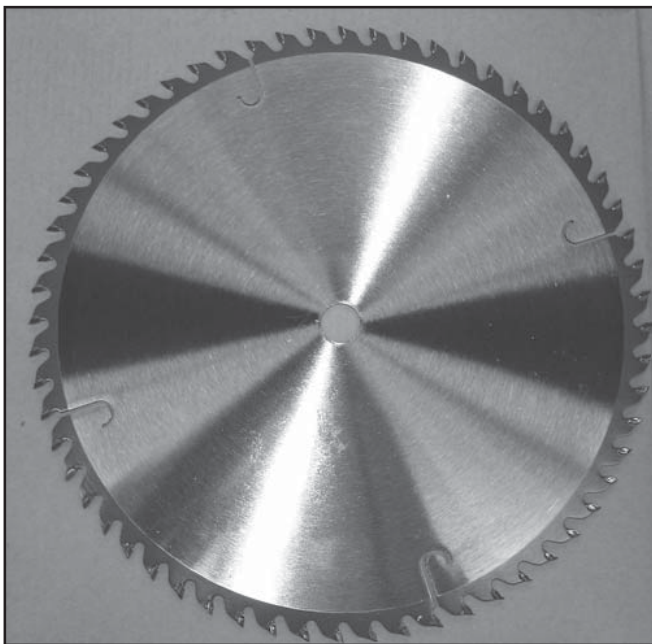

3. **Combination Blade:** Used for cutting with and across the grain. A compromise between a rip blade and a cross-cut blade, a 10" combination blade will typically have between 40-50 teeth. SEE FIG. 33.

Fig. 33

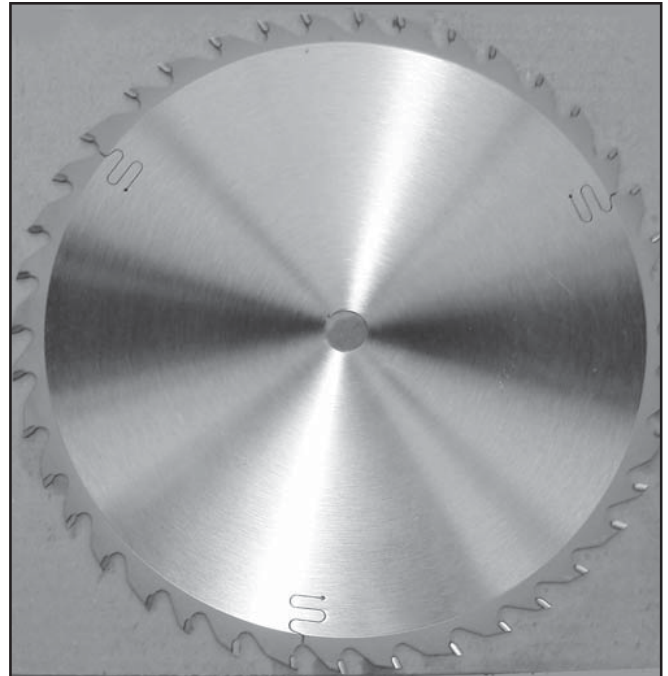

4. **Thin-kerf:** Most types of saw blades are available in a thin-kerf style. Designed primarily to minimize stock waste, thin-kerf blades are used in conjunction with a blade stabilizer to reduce blade wobble. **Note:** Many blade guards/splitters are thicker than many thin-kerf blades. Make sure that the stock will pass by the guard/splitter before beginning a cut.
5. **Dado Blades:** There are two types of dado blades: stack and wobble. Stack dados involve more set-up time, but they provide a superior finish cut when compared to a wobble dado.
6. **Moulding Heads:** A moulding head is a cutterhead that attaches to the arbor and holds individual moulding knives. They are very dangerous and require training beyond the scope of this manual.

This section on blade selection is by no means comprehensive. Always follow the saw blade manufacturer's recommendations to assure safe and efficient operation of your table saw.

CROSSCUTTING

Crosscutting means cutting across the grain of the wood. In wood products without grain (i.e. MDF, particleboard), crosscutting simply means cutting across the width of the stock.

Crosscuts are made with the miter gauge. There are two miter gauge slots in the table top. Use the one that works best for the piece being crosscut. **To make a crosscut using the miter gauge:**

1. Inspect the board for soundness. You do not necessarily need a square edge to crosscut with accuracy.
2. Inspect the miter gauge. Is it properly set and tight? Move the rip fence completely out of the way.
3. Turn on the saw and allow it to come to full speed.
4. Hold the workpiece firmly against the face of the miter gauge and ease it into the blade and through the workpiece. **SEE FIG. 34.**

Fig. 34

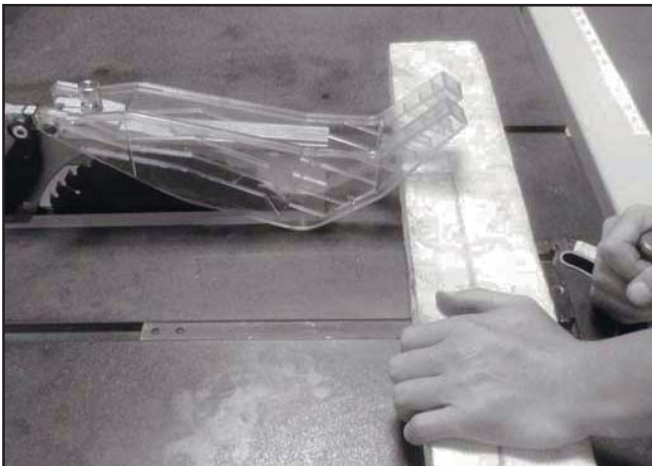

5. Turn off the saw and allow the blade to come to a full stop.

⚠ WARNING

Small cutoff pieces can contact the moving blade and be thrown back toward the operator. Always use the least amount of clearance between the table insert and the blade to reduce the risk of injury from these pieces. Never attempt to grab these pieces while the table saw is turned on. Your hand may come into contact with the blade. Turn the table saw off and safely remove these pieces AFTER the blade has come to a complete stop.

RIPPING

Ripping means to cut with the grain of the wood. In other materials such as MDF or plywood, ripping simply means to cut lengthwise. **To rip a board:**

1. Inspect the board for soundness. You will need a straightedge to rip with accuracy. Your workpiece may need to be jointed flat before attempting to cut on the table saw.

⚠ WARNING

Never attempt to rip a board that does not have one perfectly straight edge on it. Always run the straight edge of the board against the rip fence. Failure to do this could result in kickback and serious personal injury.

2. Set the rip fence to the desired distance from the blade. **IF YOU ARE MAKING NARROW CUTS, USE A PUSH-STICK** Serious injury can occur if you put your hands close to the blade. A push-stick pattern has been included at the end of this manual. Use it to hold the workpiece against the table and fence and push the workpiece fully past the blade. When a small width is to be ripped and a push-stick cannot be safely put between the blade and rip fence, rip a larger piece to obtain the desired piece.
3. Turn on the saw and allow it to reach full speed. Place the trued edge of the board against the rip fence. Feed the workpiece slowly and evenly into the blade and through the workpiece. When ripping, always stand off to the side of the workpiece and push it through, making sure to keep your fingers out of line with the blade. **SEE FIG. 35.**

Fig. 35

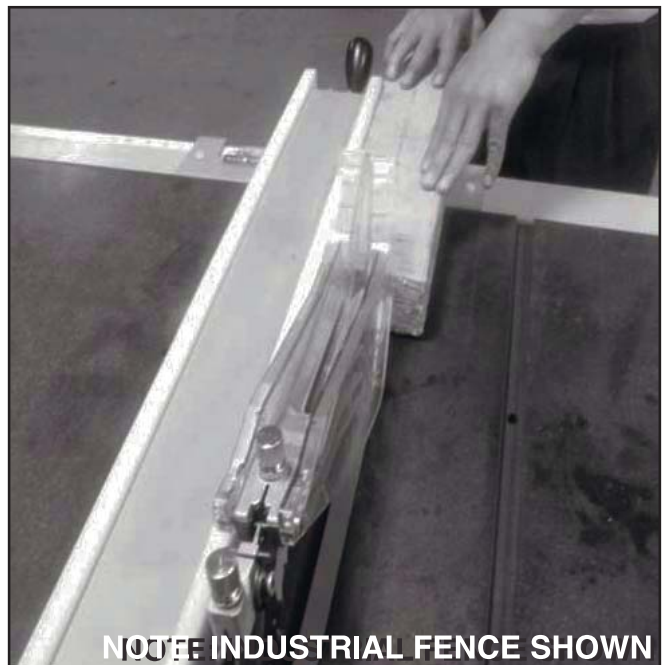

Do not stand directly behind the workpiece when ripping. SEE FIG. 36.

Fig. 36



⚠ WARNING

Stand out of the line of potential kickback. Hold the workpiece firmly against the fence and table. Do not allow your fingers to get close to the blade! Do not reach over the blade to off-load the workpiece.

DADO OPERATIONS

In addition to its ability to rip and crosscut lumber, the table saw is also an invaluable tool for creating a variety of dados. These non-through cuts can be created with specially-designed stacking or wobbling dado blades.

⚠ WARNING

Never allow hands or arms to be above or behind the saw blade. Should kickback occur, the hands and arms can be pulled into the saw blade. Serious injury will result.

⚠ WARNING

Never perform a through cut operation with a dado blade. A dado blade was designed to make non-through cuts only. Failure to follow these directions could result in serious injury.

⚠ WARNING

Dado operations present very real hazards requiring proper procedures to avoid serious injury. The chance of kickback is always greater when dado blades are used so extra precautions must be used. Any movement of the stock away from the fence will cause kickback. Be certain that stock is flat and straight. Failure to follow these warnings could result in serious personal injury.

⚠ CAUTION

Always use push sticks, featherboards, push paddles and other safety accessories whenever possible to increase safety and control during operations which require the blade guard and splitter to be removed from the saw. ALWAYS replace the blade guard after dadoing is complete.

Proper dado operations will differ depending on the blade system you choose. Consult the instructions included with your dado blades for directions regarding attachment and adjustment. To use a dado blade:

⚠ WARNING

MAKE CERTAIN THAT THE SAW IS DISCONNECTED FROM THE POWER SOURCE.

1. Remove the table insert, splitter guard, and regular saw blade.
2. Attach and adjust the dado blade system as recommended in the dado blade's instructions.
3. Install the dado table insert.
4. Raise the blade system up to the desired depth of the dado. Make sure the dado blade will not cut through the workpiece.
5. If dadoing along the length of your workpiece, adjust the distance between the fence and the inside edge of the blade to suit your needs. When cutting across the wood grain, use the miter gauge as a guide while dadoing. **Remember:** Never use the fence as a stop in conjunction with your miter gauge.
6. Reconnect the saw to the power source.
7. Using a scrap piece as a test piece, switch on the saw and take a pass over the dado blade.
8. If the cut is satisfactory, repeat with your finish stock.

MAINTAINENCE

PROTECTING CAST IRON TABLE FROM RUST

⚠ WARNING

MAKE CERTAIN THAT THE SAW IS DISCONNECTED FROM THE POWER SOURCE.

The environment and frequency of human contact can have a very detrimental impact on unpainted cast iron surface. Moisture, humidity and oils (from human hands!) can cause the unpainted cast iron surfaces to mar or rust, so it is important to conduct routine maintenance to keep your table saw looking new. Cleaning and waxing the cast iron surfaces on a regular maintenance schedule is recommended as follows:

To clean and maintain the unpainted cast iron surfaces:

- Apply a heavy coat of WD-40 onto the unpainted cast iron surface.
- Use a fine steel wood pad to buff the unpainted cast iron. Make sure to buff in a “front-to-rear” direction only. A side-to-side buffing motion will show in the finely ground cast iron as a flaw, defect or scratches.
- Reapply WD-40 and buff the unpainted cast iron surfaces until the stains or rust is removed. Make sure you use the same front-to-rear buffing direction to avoid scratching or marring the cast iron surface.
- After all stains and/or rust have been removed, clean all oil and dirt from the table saw using a soft cloth or rag.
- Lastly, you need to apply a good automotive paste wax to all unpainted cast iron surfaces. This will help to protect the saw from rusting from further contact with moisture or oily hands.

This table saw requires very little maintenance other than minor lubrication and cleaning. The following sections detail what will need to be done in order to assure continued operation of your saw.

LUBRICATION

The table saw has sealed lubricated bearings in the motor housing that do not require any additional lubrication from the operator.

Use a wire brush to clean off the worm gears and trunnions and apply a white lithium grease to keep them lubricated.

CLEANING

Keep the inside of the cabinet clear of saw dust and wood chips. With the table saw unplugged, vacuum out the inside of the cabinet or blow out the inside with an air hose. Be sure to use air pressure no higher than 50 P.S.I. as high pressure air may damage insulation.

⚠ WARNING

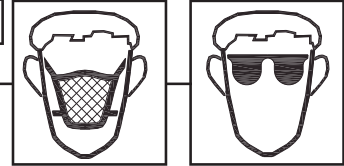

Be sure to wear protective eyewear and dust mask when cleaning out the cabinet of the saw.

LOCATE YOUR SERIAL NUMBER

The Serial Number of your unit can be located on the specification sticker label and the carton label. It is a letter L followed by 8 digit code. Please use the model number and serial number as reference. **SEE FIG. 37 & 38**

Fig. 37



Fig. 38

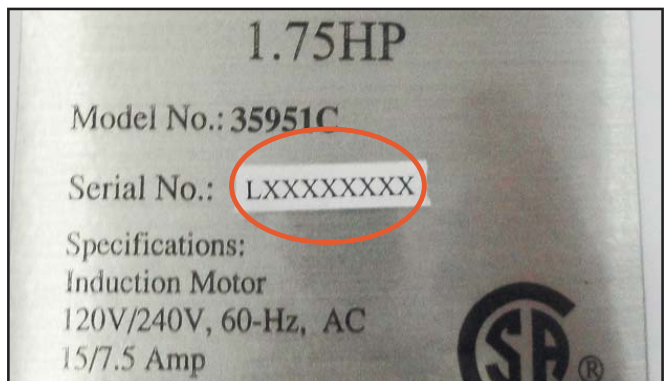

TROUBLESHOOTING GUIDE

This section covers the most common processing problems encountered in sawing and what to do about them. Do not make any adjustments until the table saw is unplugged and moving parts have come to a complete stop.

PROBLEM	LIKELY CAUSE(S)	SOLUTION
Saw stops or will not start.	<ol style="list-style-type: none"> 1. Overload tripped. 2. Saw unplugged from wall or motor. 3. Fuse blown or circuit breaker tripped. 4. Cord damaged. 	<ol style="list-style-type: none"> 1. Allow motor to cool and reset by pushing reset switch. 2. Check all plug connections. 3. Replace fuse or reset circuit breaker. 4. Replace cord.
Does not make accurate 45° or 90° cuts.	<ol style="list-style-type: none"> 1. Stops not adjusted correctly. 2. Angle pointer not set accurately. 3. Miter gauge out of adjustment. 	<ol style="list-style-type: none"> 1. Check blade with square and adjust stops. 2. Check blade with square and adjust pointer. 3. Adjust miter gauge.
Material binds blade when ripping.	<ol style="list-style-type: none"> 1. Fence not aligned with blade. 2. Warped wood. 3. Excessive feed rate. 4. Splitter not aligned with blade. 	<ol style="list-style-type: none"> 1. Check and adjust fence. 2. Select another piece of wood. 3. Reduce feed rate. 4. Align splitter with blade.
Saw makes unsatisfactory cuts.	<ol style="list-style-type: none"> 1. Dull blade. 2. Blade mounted backwards. 3. Gum or pitch on blade. 4. Incorrect blade for cut. 5. Gum or pitch on table. 	<ol style="list-style-type: none"> 1. Sharpen or replace blade. 2. Turn blade around. 3. Remove blade and clean. 4. Change blade to correct type. 5. Clean table.
Blade does not come up to speed.	<ol style="list-style-type: none"> 1. Extension cord too light or too long. 2. Low shop voltage. 3. Motor not wired for correct voltage. 	<ol style="list-style-type: none"> 1. Replace with adequate size cord. 2. Contact your local electric company. 3. Refer to motor junction box.
Saw vibrates excessively.	<ol style="list-style-type: none"> 1. Stand on uneven floor. 2. Damaged saw blade. 3. Bad poly V-belts. 4. Bent pulley. 5. Improper motor mounting. 6. Loose hardware. 7. Loose set screw in pulley. 	<ol style="list-style-type: none"> 1. Reposition on flat, level surface. 2. Replace saw blade. 3. Replace poly V-belts. 4. Replace pulley. 5. Check and adjust motor. 6. Tighten hardware. 7. Tighten set screw.
Rip fence binds on guide rails.	<ol style="list-style-type: none"> 1. Guide rails or extension wing not installed correctly. 2. Guide of rip fence not adjusted properly. 	<ol style="list-style-type: none"> 1. Reassemble guide rails, refer to fence manual. 2. Adjust guides, refer to fence manual.
Material kicked back from blade.	<ol style="list-style-type: none"> 1. Rip fence out of alignment. 2. Splitter not aligned with blade. 3. Feeding stock without rip fence. 4. Splitter not in place. 5. Dull blade. 6. Letting go of material before it is past blade. 7. Anti-kickback fingers dull. 	<ol style="list-style-type: none"> 1. Align rip fence with miter slot. 2. Align splitter with blade. 3. Install and use rip fence. 4. Install and use splitter (with guard). 5. Replace blade. 6. Push material all the way past blade before releasing work. 7. Replace or sharpen anti-kickback fingers.
Blade does not raise or tilt freely.	<ol style="list-style-type: none"> 1. Sawdust and debris in raising and tilting mechanisms. 	<ol style="list-style-type: none"> 1. Clean and grease.

◆ NOTES ◆

PARTS

35951G
35951C

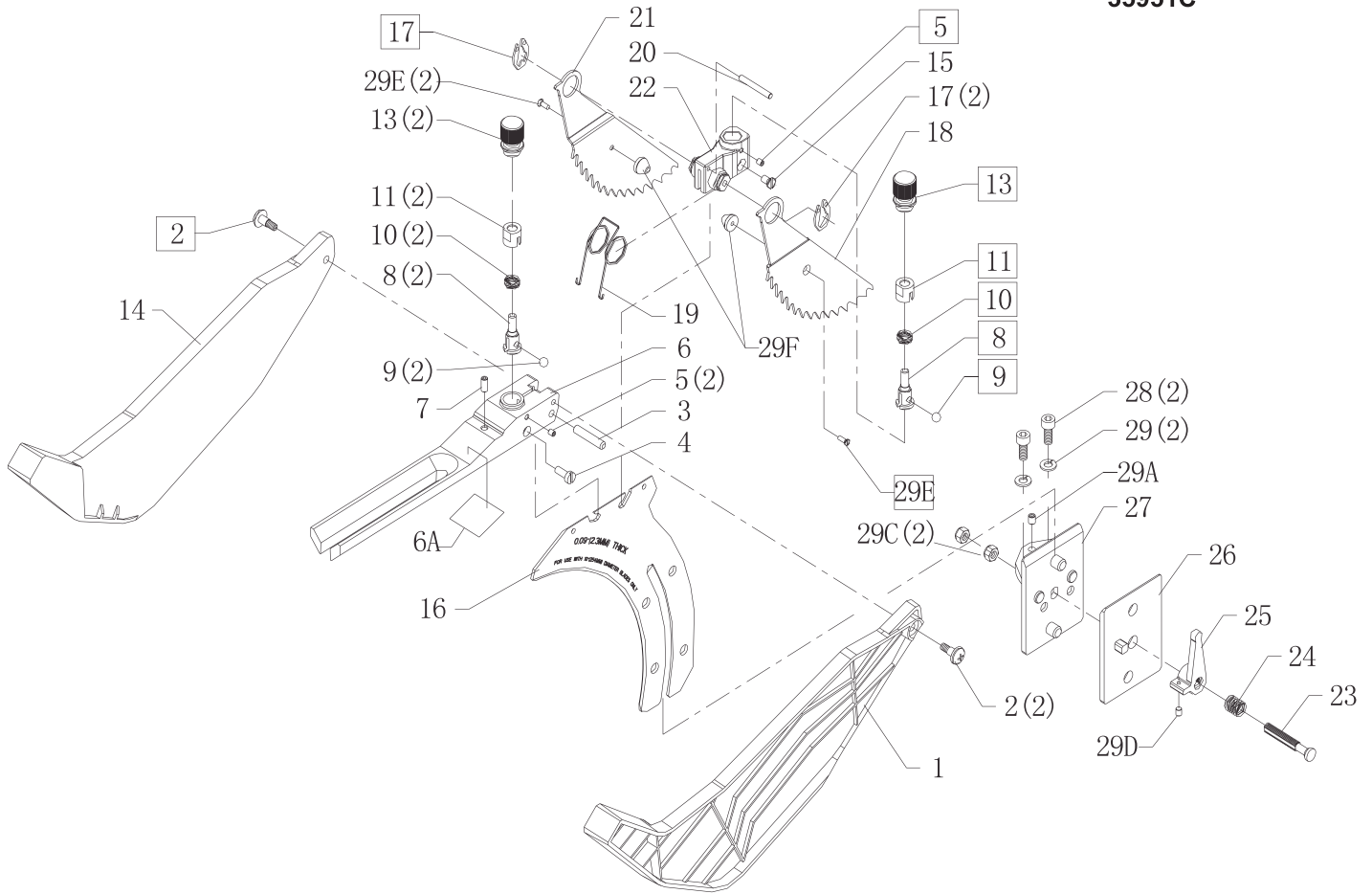

KEY NO.	PART NO.	DESCRIPTION	QTY	KEY NO.	PART NO.	DESCRIPTION	QTY
1	SC10464	RIGHT BLADE GUARD	1	18	SC10475	RIGHT ANTI KICKBACK FINGER	1
2	SC10465	SHOULDERED SCR	2	19	SC10476	TWIST SPRING	1
3	SC10466	ROUND PIN	2	20	SC84302	∅ 3X30mm SPRING PIN	1
4	SC80439	M4X10mm ROUND HD CUTTING SCR	1	21	SC10477	LEFT ANTI KICKBACK FINGER	1
5	SC80318	M4X6mm HEX SOC SET SCR W/FLAT POINT	2	22	SC10478	ANTI KICKBACK FINGER SUPPORT	1
6	SC10467	BLADE GUARD SUPPORT ARM	1	23	SC10479	SPECIAL BOLT	1
6A	SC76039	WARNING LABEL	1	24	SC10480	SPRING	1
7	SC80319	M5X12mm HEX SOC SET SCR W/CONE POINT	1	25	SC10481	FAST NUT BASE	1
8	SC10468	FIXED SHAFT	2	26	SC10482	RIVING KNIFE PLATE	1
9	SC10469	7/32 STEEL BALL	2	27	SC10483	RIVING KNIFE SUPPORT	1
10	SC10470	SPRING	2	28	OR93372	SCR SOC HD CAP M6 X 12mm	2
11	SC10471	BUSHING	2	29	OR90502	M6 LOCK WASHER	2
13	SC10472	TWIST GRIP	2	29A	SC80321	M6X8mm HEX SOC HD SCR WITH FLAT POINT	1
14	SC10473	LEFT BLADE GUARD	1	29C	SC81113	M8 LOCK NUT(LEFT)	2
15	OR95116	M4X8mm COUNTERSUNK HD SCR	1	29D	SC80322	M5X10mm HEX SOC HD SCR WITH FLAT POINT	1
16	SC10474	RIVING KNIFE 2.3MM	1	29E	SC80437	ST2.9X6.5 CROSS COUNTERSUNK TAP SCR	2
17	OR94858	RETAINING RING E-RING 9	2	29F	SC10484	ANTI KICKBACK FINGER SUPPORT BEARER	2

Switch Assembly--OR91712 1.75 HP/110V

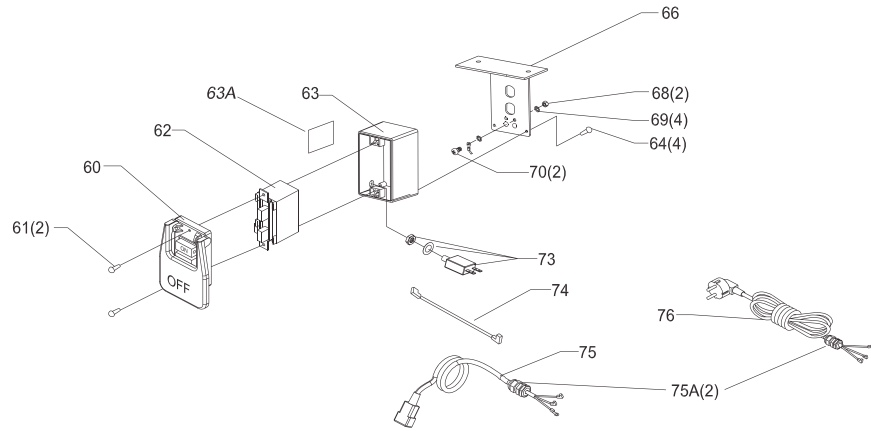

Miter Gauge Assembly--SC10160

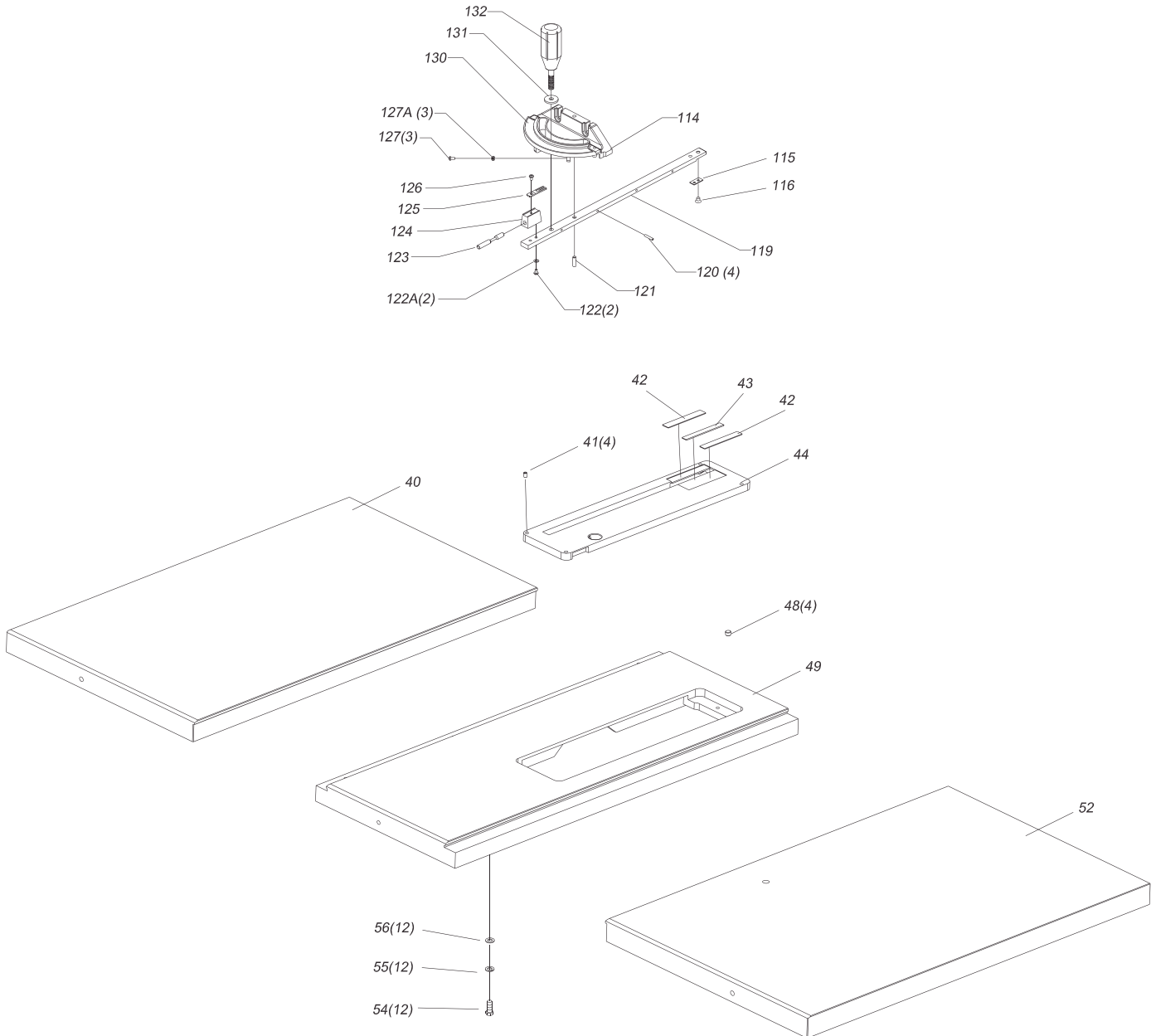

KEY NO.	PART NO.	DESCRIPTION	QTY
35951C			
40	SC10755	LEFT EXTENSION WING	1
41	OR91789	1/4-28X 3/8" SET SCREW	4
42	SC10154	TABLE INSERT LEFT PAD	2
43	SC10155	TABLE INSERT RIGHT PAD	1
44	SC10486	TABLE INSERT	1
48	SC10487	Φ8X5mm MAGNET	4
49	SC10756	TABLE ASSY	1
52	SC10757	RIGHT EXTENSION WING	1
54	SC80470	5/16-18X50mm HEX BOLT	12
55	OR90248	M8 LOCK WASHER	12
56	OR91084	SPECIAL WASHER(8.3X25X3.5)	12

35951G

40	SC10766	LEFT EXTENSION WING	1
41	OR91789	1/4-28X 3/8" SET SCREW	4
42	SC10154	TABLE INSERT LEFT PAD	2
43	SC10155	TABLE INSERT RIGHT PAD	1
44	SC10486	TABLE INSERT	1
48	SC10487	Φ8X5mm MAGNET	4
49	SC10767	TABLE ASSY	1
52	SC10768	RIGHT EXTENSION WING	1
54	SC80470	5/16-18X50mm HEX BOLT	12
55	OR90248	M8 LOCK WASHER	12
56	OR91084	SPECIAL WASHER(8.3X25X3.5)	12

KEY NO.	PART NO.	DESCRIPTION	QTY
*	OR91712	SWITCH ASSY(#60-#76)	
60	OR91060	SWITCH PADDLE	1
61	SC80411	M4X25mm ROUND HD TAP SCR	2
62	OR90343	SWITCH	1
63	OR91063	SWITCH BOX	1
63A	OR91579	SWITCH RESET LABEL	1
64	SC80410	M4X16 ROUND HD TAP SCR	4
66	OR91062	SWITCH SUPPORT	1
68	OR90381	M5 HEX NUT	2
69	OR90362	M5 EXT TOOTH WASHER	4
70	OR90505	M5X12 PAN HD SCR	2
73	OR70139	RESET SWITCH (25Amp,125/250V)	1
74	OR91032	WIRE JUMPER (BLACK)	1
75	OR91007	SWITCH CORD	1
75A	OR70141	STRAIN RELIEF(7P-2)	2
76	OR91030	POWER CORD	1
*	SC10160	MITER GAUGE ASSY(#114-#132)	
114	OR91076	MITER GAUGE BODY	1
115	SC10161	SPECIAL WASHER	3
116	SC10162	SPECIAL SCREW	2
119	SC10163	GUIDE BAR	1
120	OR91763	M4 X 16MM SET SCREW	4
121	OR91783	1/4"x3/4 PIN	1
122	OR91774	M4X10 PAN HD SREW	2
122A	OR90143	M4 FLAT WASHER	2
123	OR91080	PLUNGER	1
124	OR91081	PLUNGER BLOCK	1
125	OR91082	CURSOR	1
126	OR91775	M4X15 PAN HD SCREW	1
127	OR94404	M4X20 PAN HD SCREW	3
127A	OR90078	M4 HEX NUT	3
130	OR91573	MITER SCALE	1
131	OR91084	SPECIAL WASHER	1
132	SC10153	MITER GAUGE KNOB	1

35951C
35951G

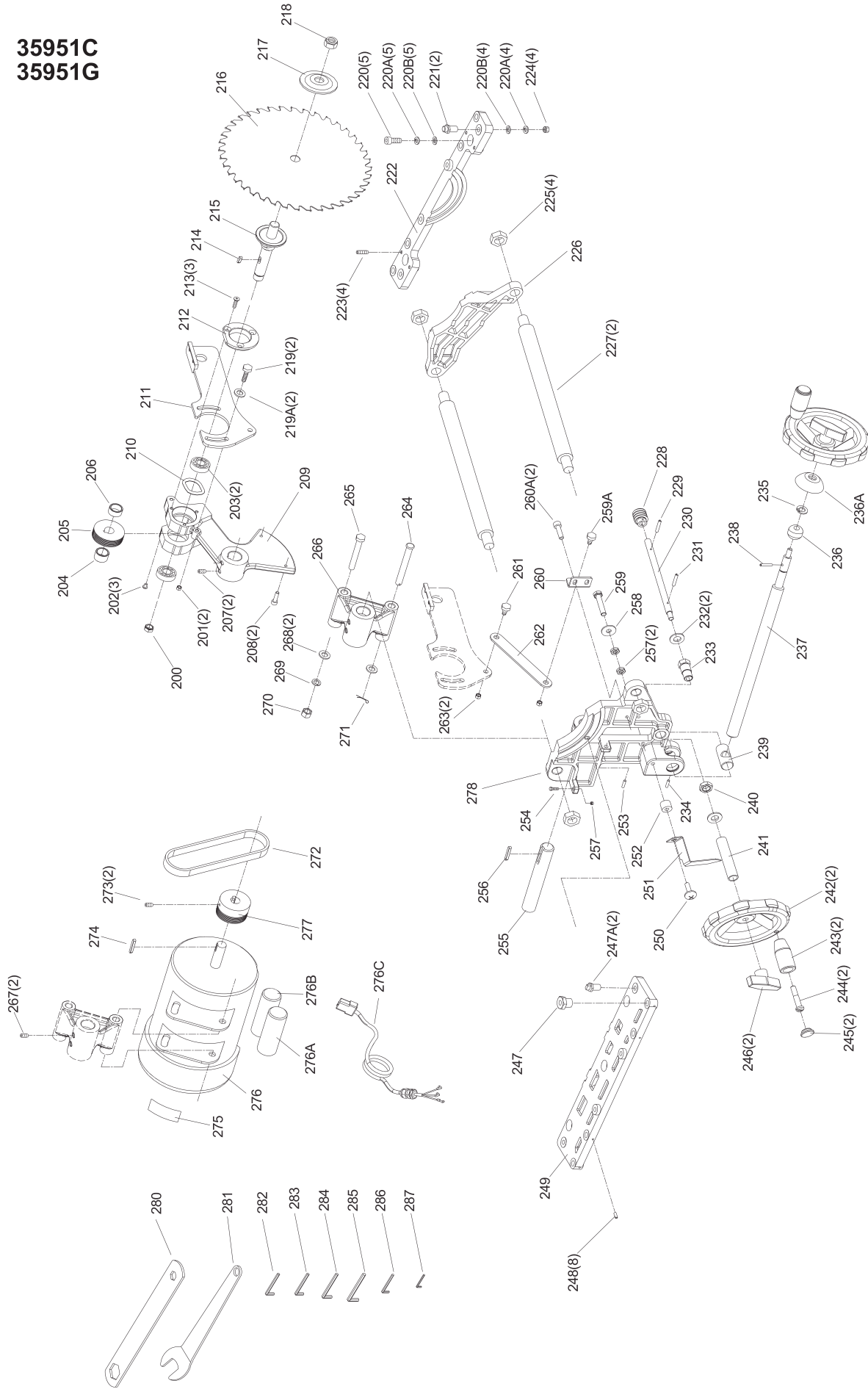

KEY NO.	PART NO.	DESCRIPTION	QTY	KEY NO.	PART NO.	DESCRIPTION	QTY
200	OR91766	5/8-18 JAM NUT	1	242	SC10722	HANDWHEEL	2
201	OR90235	M6 HEX NUT	2	243	OR72942	ELEVATING KNOB ASSY	2
201	OR92137	M5X12mm PAN HD SCR	3	244	OR91038	KNOB BOLT	2
203	OR91733	(6203 LLB) BALL BEARING	2	245	OR70157	KNOB END CAP	2
204	SC10491	BUSHING	1	246	OR91046	HANDWHEEL LOCK KNOB	2
205	SC10492	ARBOR PULLEY	1	247	OR72944	ADJUSTMENT SCREW	8
206	SC10493	BUSHING	1	247A	SC10761	PIN	2
207	SC80113	M8X8mm HEX SOC HD SCR	2	248	OR93906	SCR HEX SOC SET M5 X 6mm	8
208	SC80104	M6X10mm HEX SOC HD SCR	2	249	SC10743	REAR BRACKET	1
209	SC10494	ARBOR RAISING SUPPORT BRACKET	1	250	SC80469	M6X25 PAN HD SCR	1
210	OR91801	WAVE WASHER	1	251	SC10506	POINTER	1
211	SC10495	SPLITTER MOUNT SUPPORT	1	252	SC10762	BUSHING	1
212	SC10496	FLANGE	1	253	OR90308	M8X30mm SET SCR	1
213	SC80325	M5X12mm HEX SOC HD SCR	3	254	OR93891	M8X40mm HEX HD SCR	1
214	OR91824	5X5X15 KEY	1	255	SC10507	SHAFT	1
215	SC10497	ARBOR SHAFT	1	256	OR74452	6X6X35 KEY	1
216	OR70400	BLADE (RA-10*3.2*5/8-40T-STL)	1	257	OR90307	M8 HEX NUT	3
217	OR91026	BLADE FLANGE	1	258	OR91084	SPECIAL WASHER(8.3X25X3.5)	1
218	SC10540	ARBOR NUT	1	259	OR93891	M8X40mm HEX HD SCR	1
219	OR73016	M6X35mm HEX SOC HD SCR	2	259A	SC10508	SCREW	1
219A	OR90059	M6 FLAT WASHER	2	260	SC10509	SUPPORT BOARD	1
220	OR91761	M8X25mm SOC HEX HD SCR	5	260A	SC80104	M6X10mm HEX SOC HD SCR	2
220A	OR90248	M8 LOCK WASHER	9	261	SC10510	SCREW	1
220B	OR91084	SPECIAL WASHER(8.3X25X3.5)	9	262	SC10511	LINK ROD	1
221	SC10738	PIN	2	263	OR91754	M6 NYLON HEX NUT	2
222	SC10737	REAR BRACKET	1	264	SC84303	8X90 B PIN	1
223	OR91821	M8X20MM HEX SOC SET SCREW	4	265	SC80706	M8X100mm HEX HD SCR	1
224	OR90307	NUT HEX M8	4	266	SC10512	MOTOR SUPPORT BRACKET	1
225	OR91766	5/8-18 LOCK NUT	4	267	SC80323	M8X8mm HEX HD SET SCR	2
226	SC10499	REAR TRUNNION	1	268	OR90311	M8 FLAT WASHER	2
227	SC10500	TIE BAR	2	269	OR90248	M8 LOCK WASHER	1
*	SC10758	ELEVATING SHAFT ASSY(#228-#230)	1	270	OR90307	M8 HEX NUT	1
228	OR91744	GEAR	1	271	SC84307	B PIN	1
229	OR91792	3 x 15mm SPRING PIN	1	272	SC10513	6PJ 434 BELT	1
230	SC10759	ELEVATING SHAFT	1	273	SC80409	1/4-20 x 3/8" ROUND HD TAP SCREW	2
231	OR90232	4 x20mm SPRING PIN	1	274	OR91770	5X5X36mm KEY	1
232	OR91740	3/8" FIBER WASHER	2	275	SC76014	MOTOR LABEL 1.75HP	1
233	SC10501	ECCENTRIC SCR	1	276	SC90011	MOTOR ASSEMBLY 1.75 HP	1
234	OR93906	M5X6mm HEX SOC HD SCR	1	276A	SC72067	RUN CAPACITOR,35uF/300V	1
*	SC10542	TILT SHAFT ASSY(#235-#237)	1	276B	SC72066	START CAPACITOR,300uF/150V	1
235	SC85308	RETAINING RING ϕ 9	1	276C	OR91007	CORD W/FEMALE DISCONNECTOR	1
236	SC10740	SUPPORT BUSHING	1	277	OR91023	MOTOR PULLEY	1
236A	SC10741	FLANGE	1	278	SC10514	REAR TRUNNION	1
237	SC10742	TILT SHAFT	1	280	SC10515	7/8"X1/2" WRENCH	1
238	OR90232	4 x20mm SPRING PIN	1	281	SC10516	OPEN END WRENCH--22MM	1
239	SC10502	TILE NUT	1	282	OR90289	2.5MM ALLEN WRENCH	1
240	OR91766	5/8-18 LOCK NUT	1	283	OR90290	3MM ALLEN WRENCH	1
241	SC10760	BUSHING	1	284	OR90291	4MM ALLEN WRENCH	1
				285	OR91728	5MM ALLEN WRENCH	1
				286	OR92172	6MM ALLEN WRENCH	1
				287	OR91808	1/8" MM ALLEN WRENCH	1

**35951C
35951G**

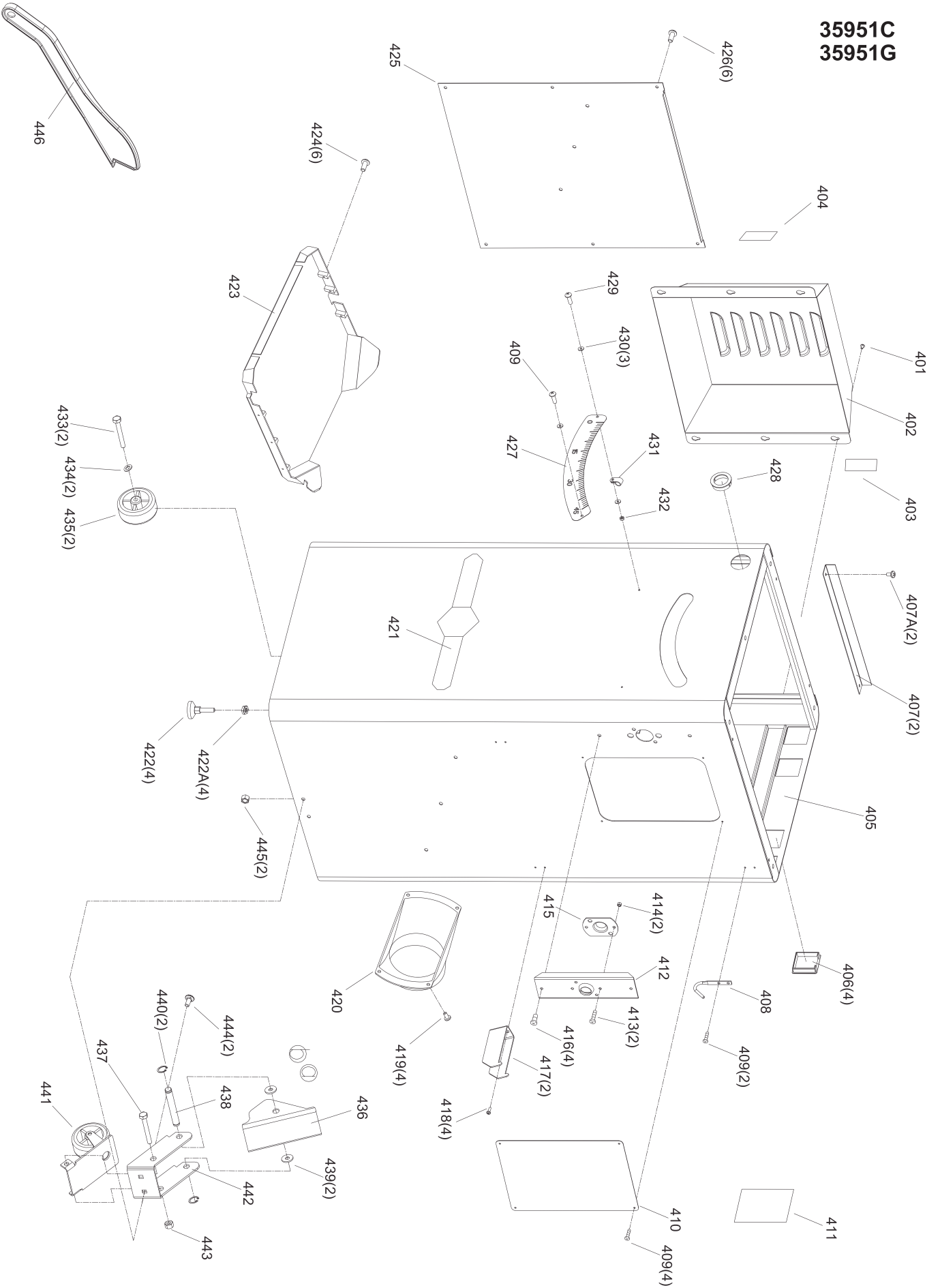

KEY NO.	PART NO.	DESCRIPTION	QTY	KEY NO.	PART NO.	DESCRIPTION	QTY
401	OR90761	M5X10mm PAN HD SCR	6	422A	OR90307	M8 HEX NUT	4
402	SC10520	MOTOR COVER	1	423	OR91124	DUST CHUTE	1
403	SC10212	BIG WARNING LABEL	1	424	OR91787	1/4-20x3/8 ROUND HD TAP SCR	6
404	SC10215	SMALL WARNING LABEL	1	425	SC10765	CABINET SIDE PANEL	1
405	SC10763	CABINET WELDMENT ASSY	1	426	OR91787	1/4-20x3/8 ROUND HD TAP SCR	6
406	SC10456	END CAP	4	427	SC76045	BEVEL SCALE	1
407	SC10764	SUPPORT PLATE	2	428	OR91106	INSULATOR	1
407A	OR90761	M5X10mm PAN HD SCR	4	429	OR91775	M4X15mm PAN HD SCR	1
408	OR91134	WRENCH HOOK	1	430	OR90143	M4 FLAT WASHER	3
409	OR91832	M4X8 TRIANGULAR THREAD TAP SCR	7	431	OR91737	CABLE CLAMP	1
410	SC10523	CABINET ACCESS DOOR	1	432	OR90078	M4 HEX NUT	1
411	SC76075	SPEC LABEL FOR 35951G	1	433	OR91497	SCR HEX HD M8 X 50mm	2
411	SC76076	SPEC LABEL FOR 35951C	1	434	OR90311	M8 FLAT WASHER	2
412	SC10524	SUPPORT BOARD	1	435	OR91505	WHEEL	2
413	OR90761	M5X10mm PAN HD SCR	2	436	OR91469	FOOT PEDAL	1
414	OR94428	M5 LOCK NUT	2	437	OR91502	SCR HEX HD 5/16-18 X 4"	1
415	SC10525	FIXED BOARD	1	438	OR91508	PIN	1
416	OR91787	1/4-20 x3/8 ROUND HD TAP SCR	4	439	OR91504	WASHER FLAT 1/2"	2
417	OR91135	FENCE BRACKET	2	440	OR91507	RETAINING RING EXTERNAL 1/2"	2
418	OR91787	1/4-20 x3/8 ROUND HD TAP SCR	4	441	OR91506	CASTER ASSEMBLY	1
419	OR91833	SCR PAN HD TAP 1/4-20 X 1/2	4	442	OR72922	REAR WHEEL BRACKET	1
420	OR91128	DUST PORT	1	443	OR91503	NUT LOCK 5/16-18	1
421	OR70003	NAME PLATE	1	444	OR94775	SCR CARRIAGE HD M8 X 20mm	2
422	SC10529	LEVELING SCREW	4	445	OR94771	NUT HEX FLANGE M8	2

◆ NOTES ◆

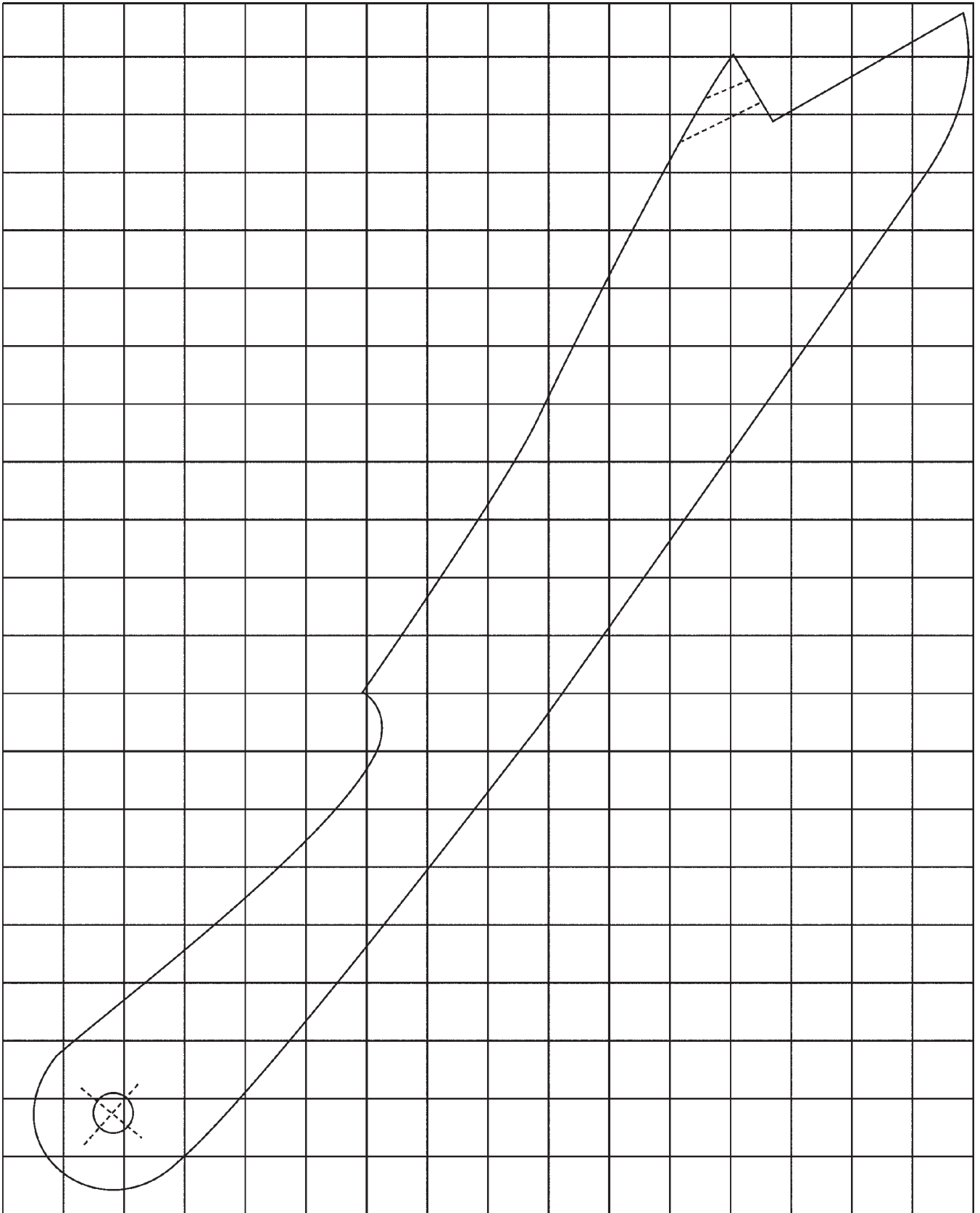



STEEL CITY TOOL WORKS

www.steelcitytoolworks.com

1-877-SC4-TOOL
(1-877-724-8665)

5 Year Warranty



A T T E N T I O N

Spacer use for setting the wings on your new Steel City table saw.



1. Mount the left and right wings onto the top of your table saw but do not tighten bolts at this time.
2. Insert a spacer in the miter slot at front and rear of the table saw.
3. Use your hand to hold the wing tight against the main table.
4. Tighten the bolts and remove the spacers.
5. Test the miter gauge in the slot, adjust if necessary.
6. Repeat on the other wing.
7. Save you spacers with your manual for future use. i.e. move the table saw from your garage to your new workshop.

Please note the miter gauge is a standard size, measuring 19mm (3/4") and the spacers are 19.2mm each.

