

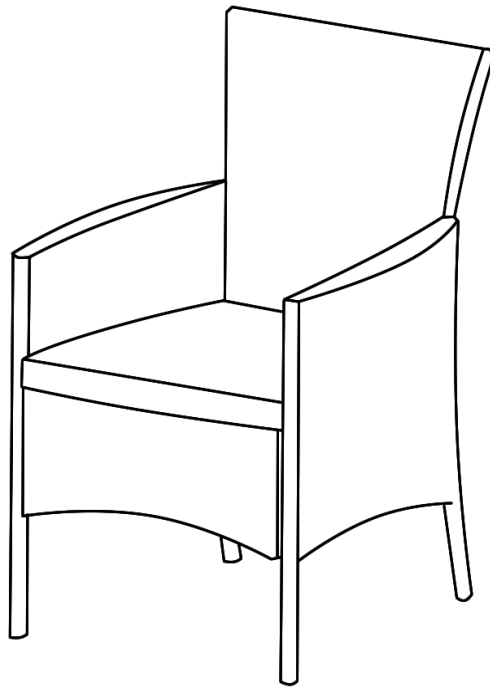



Assembly Instructions

Caution : You must read this before you proceed

Dinning Chair



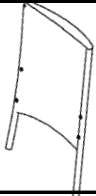
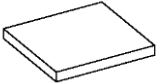

Parts List

Label	Picture	Description	QTY
A		Backrest	1
B		Seat	1
C		Right Armrest / Leg	1

D		Left Armrest /Leg	1
E		Seat Cushion	1

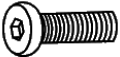
Hardware

Label	Picture	Description	QTY
F		Bolt(M6*35MM)	12
G		Washer	12
H		Allen Key	1

Assembly Preparation

Before Beginning Assembly:

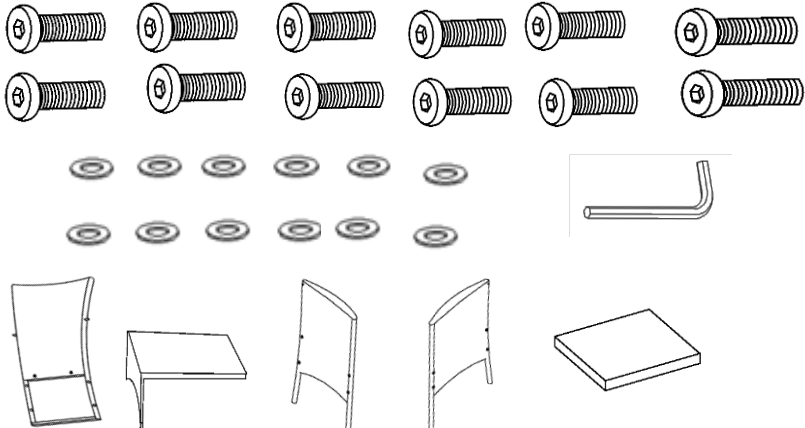

- Read instructions, cover to cover-



- Have 2 adults on hand for assembly-



- Do not assemble on flooring or carpet-



- Assemble on a clean non-marring surface (packing foam)-



- Save all packaging until finished-

Assembly Steps

Step 1

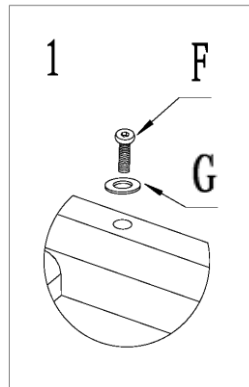
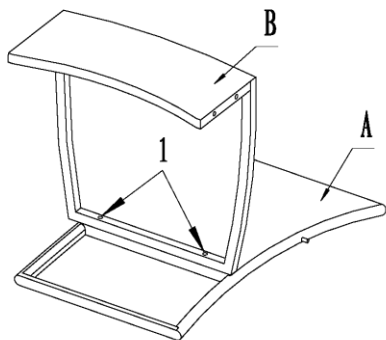

Open the carton and place all the parts onto a clean and soft surface.
Unpack all packages of hardware.
Place the Backrest (A) with its inside facing skywards.
Attach Seat(B) to Backrest(A) using Hardware(H, G) with Allen Key(H).
LOOSELY TIGHTEN.

ATTENTION: Occasionally some of the PE Wicker shifts and covers the mounting positions preventing easy assembly.
The PE wicker should never be cut, but moved away from the mounting positions.

Step 2

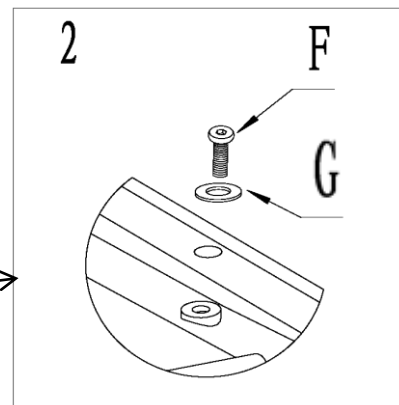
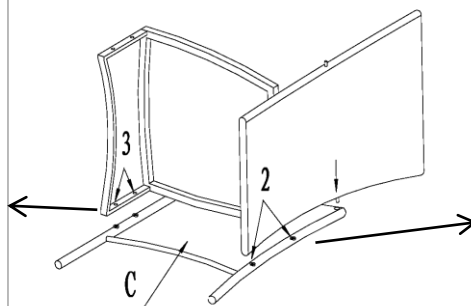
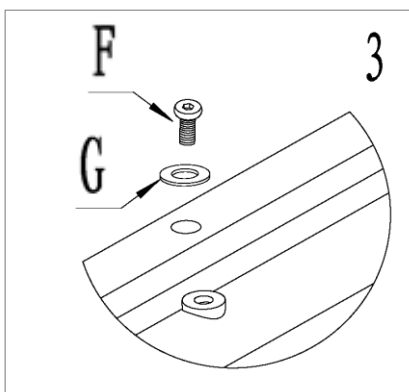

Place the Right Armrest/Leg(C), as picture above so as to be attached to the Backrest (A) and Seat(B) using Hardware(F, G) with Allen Key(H).
LOOSELY TIGHTEN.

Step 3

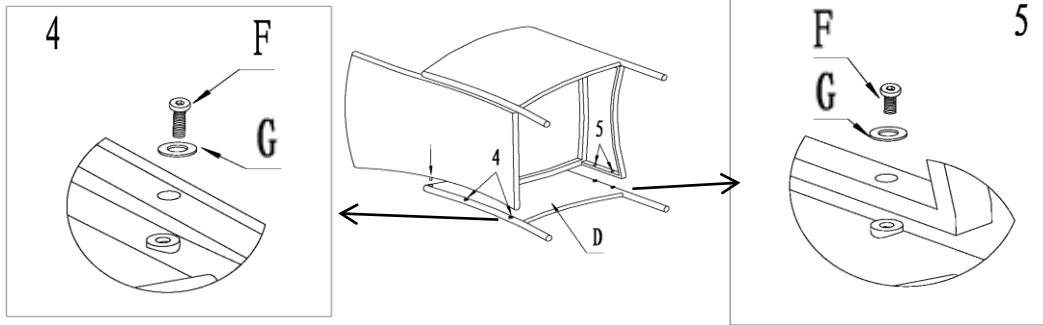

Place the Left Armrest/Leg (D) as pictured above and affix to Backrest (A) and Seat(B) using Hardware(F, G) with Allen Key(H) as shown in Picture 4 and Picture 5.

LOOSELY TIGHTEN.

Step 4

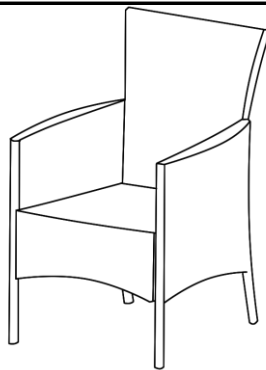

Stand CHAIR rightside up.
Check stability and then tighten the bolts.

Note: DO NOT fully tighten a BOLT in one go and then move on to the next. Rather, In a sequential manner, gradually tighten each Bolt until all bolts are evenly secured. This methodology will ensure maximum evenness once all Bolts are fully tightened.

Step 5

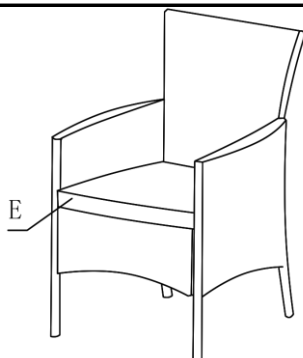

Put the Seat Cushion(E) on the Seat.
Your Chair is ready for use.

Care & Maintenance



- Do not put hot items directly on furniture surface.



- Do not clean furniture with harsh cleansers or polish.



- To obtain the longest lifespan of your outdoor products, minimizing exposure to direct sunlight is recommended.



- Children should not climb or jump on the furniture.



- Do not write on furniture without a padded barrier to protect the surface.



- To obtain the longest lifespan of your outdoor products, avoid extended and lengthy exposure to rain, snow, and direct sunshine. Whenever possible cover the product and /or place under patio or awnings.



- Not for commercial use. For residential use only .



- Stains may be removed with mild soap solution and damp cloth.



- Keep away from sources of ignition.



- Dust and pick-up spills using a clean, non-colored, lint-free cloth .