

HILTI

TE 30 /
TE 30-AVR /
TE 30-C-AVR /
TE 30-M-AVR

Bedienungsanleitung

de

Operating instructions

en

Mode d'emploi

fr



CE

1

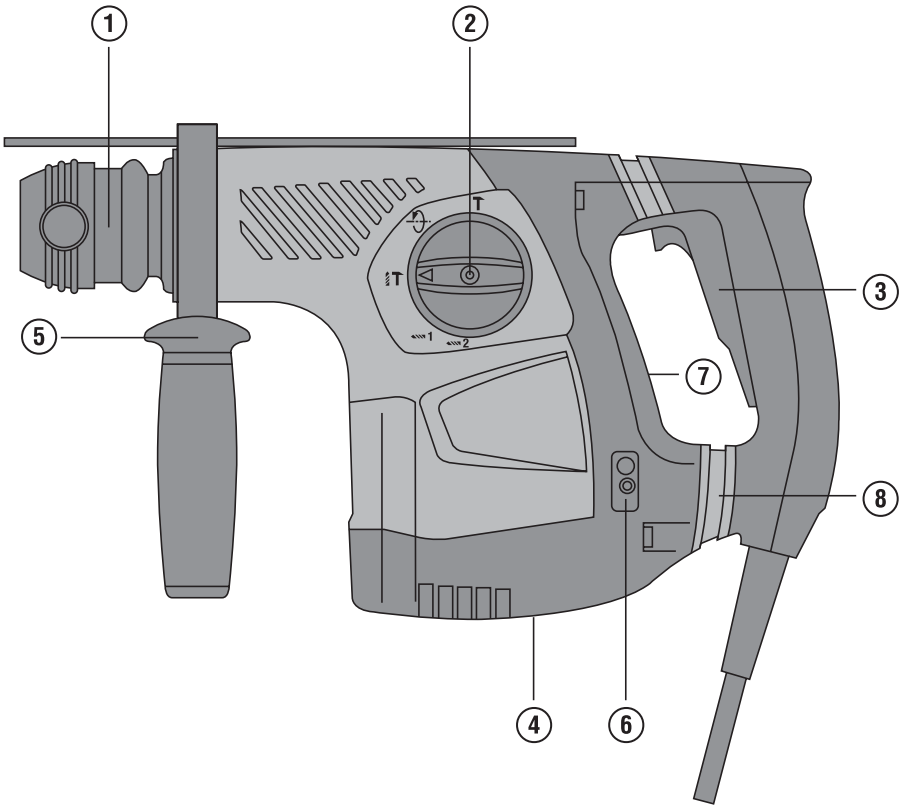

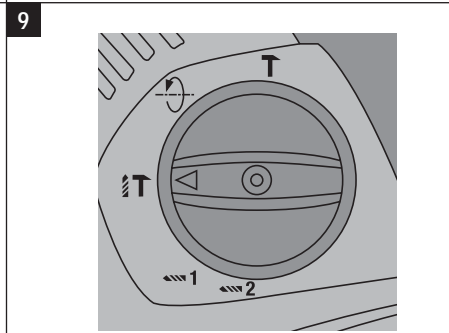
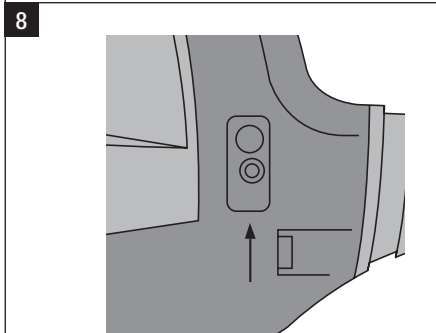
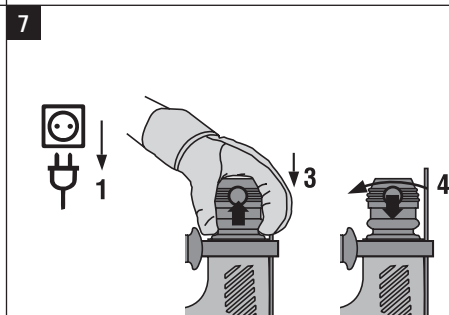
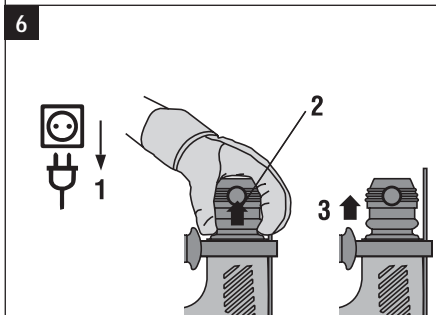
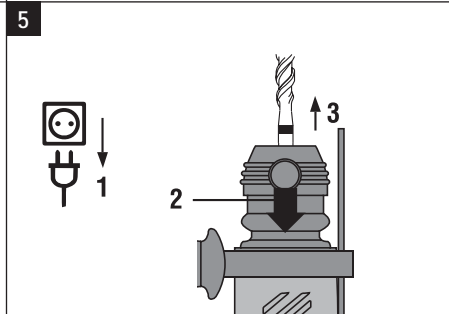
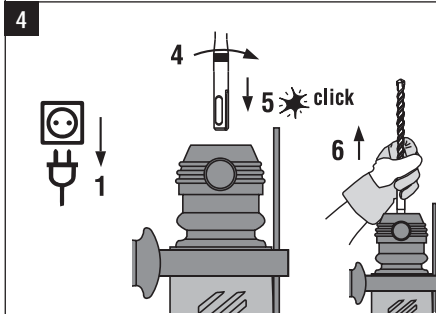
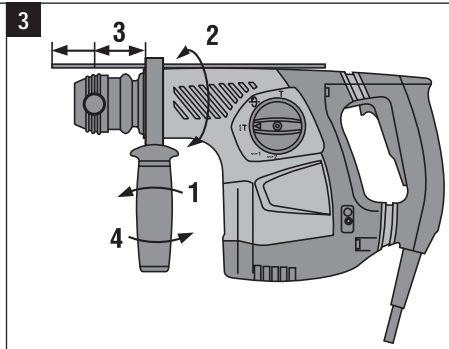
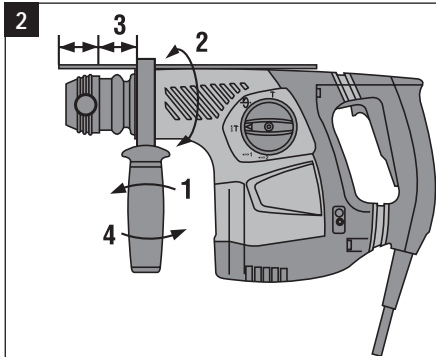

10

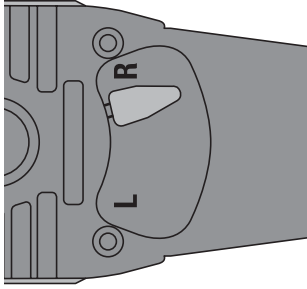

ORIGINAL OPERATING INSTRUCTIONS

TE 30 / TE 30-AVR / TE 30-C-AVR / TE 30-M-AVR rotary hammer

en

It is essential that the operating instructions are read before the power tool is operated for the first time.

Always keep these operating instructions together with the power tool.

Ensure that the operating instructions are with the power tool when it is given to other persons.

Contents	Page
1. General information	1
2. Description	2
3. Insert tools, accessories	5
4. Technical data	5
5. Safety instructions	7
6. Before use	10
7. Operation	10
8. Care and maintenance	12
9. Troubleshooting	13
10. Disposal	14
11. Manufacturer's warranty - tools	14
12. EC declaration of conformity	15

■ These numbers refer to the corresponding illustrations. The illustrations can be found on the fold-out cover pages. Keep these pages open while studying the operating instructions.

In these operating instructions, the designation "the power tool" always refers to the TE 30, TE 30-AVR, TE 30-C-AVR or TE 30-M-AVR rotary hammer.

Components, operating controls and indicators ■

- ① Chuck
- ② Function selector switch
- ③ Control switch
- ④ Forward / reverse switch
- ⑤ Side handle with depth gauge
- ⑥ TPS indicator (TE 30-M-AVR)
- ⑦ Signal receiving area for the TPS key
- ⑧ AVR Active Vibration Reduction (optional)

1. General information

1.1 Safety notices and their meaning

DANGER

Draws attention to imminent danger that could lead to serious bodily injury or fatality.

WARNING

Draws attention to a potentially dangerous situation that could lead to serious personal injury or fatality.

CAUTION

Draws attention to a potentially dangerous situation that could lead to slight personal injury or damage to the equipment or other property.

NOTE

Draws attention to an instruction or other useful information.

1.2 Explanation of the pictograms and other information

Warning signs



General warning



Warning: electricity

en

Obligation signs



Wear eye protection



Wear a hard hat



Wear ear protection



Wear protective gloves



Wear breathing protection

Symbols



Read the operating instructions before use



Equipped with theft protection system



Lock symbol



Return waste material for recycling.



Double insulated



Drilling without hammering

1



Drilling without hammering, 1st gear

2



Drilling without hammering, 2nd gear



Hammer drilling



Chiseling



Chisel position adjustment

Location of identification data on the power tool

The type designation can be found on the type identification plate and the serial number on the side of the motor housing. Make a note of this data in your operating instructions and always refer to it when making an enquiry to your Hilti representative or service department.

Type:

Generation: 01

Serial no.:

2. Description

2.1 Use of the product as directed

The power tool is an electrically-powered rotary hammer with pneumatic hammering mechanism.

The power tools are designed for drilling in concrete and masonry. The power tool can also be used for light chiseling work on masonry and surface finishing on concrete.

Working on materials hazardous to the health (e.g. asbestos) is not permissible.

Nationally applicable industrial safety regulations must be observed.

The working environment may be as follows: construction site, workshop, renovation, conversion or new construction.

The power tool may be operated only when connected to a power supply providing a voltage and frequency in compliance with the information given on its type identification plate.

The power tool is designed for professional use and may be operated, serviced and maintained only by trained, authorized personnel. This personnel must be informed of any special hazards that may be encountered. The

power tool and its ancillary equipment may present hazards when used incorrectly by untrained personnel or when used not as directed.

To avoid the risk of injury, use only genuine Hilti accessories and insert tools.

Observe the information printed in the operating instructions concerning operation, care and maintenance.

Modification of the power tool or tampering with its parts is not permissible.

en

2.2 Chuck

TE-C (SDS plus) chuck

TE-T (SDS top) chuck

2.3 TPS TE 30-M-AVR theft protection system (optional)

The power tool may be equipped with the optional theft protection system. If the power tool is equipped with this feature, it can be unlocked and made ready for operation only through use of the corresponding TPS key.

2.4 TE 30 / TE 30-AVR switch

Speed control switch for smooth starting.

Forward / reverse switch

Function selector switch:

Drilling without hammering

Hammer drilling

2.5 TE 30-C-AVR switch

Speed control switch for smooth starting.

Forward / reverse switch

Function selector switch:

Drilling without hammering

Hammer drilling

Chisel adjustment (12 positions)

Chiseling

2.6 TE 30-M-AVR switch

Speed control switch for smooth starting.

Forward / reverse switch

Function selector switch:

Drilling without hammering 2

Drilling without hammering 1

Hammer drilling

Chisel adjustment (12 positions)

Chiseling

2.7 Grips

Pivotable side handle with depth gauge

Vibration-absorbing grip

2.8 Protective feature

Mechanical slip clutch

2.9 Lubrication

Oil lubrication

2.10 Active vibration reduction (TE 30-AVR, TE 30-C-AVR, TE 30-M-AVR)

en

The power tool is equipped with an AVR active vibration reduction system which reduces vibration significantly compared to power tools without AVR.

2.11 Items supplied as standard

- 1 Power tool
- 1 TE-C or TE-T chuck
- 1 Side handle with depth gauge
- 1 Operating instructions
- 1 Hilti toolbox
- 1 Cleaning cloth
- 1 Grease

2.12 Using extension cords

Use only extension cords of a type approved for the application and with conductors of adequate cross section. The power tool may otherwise lose performance and the extension cord may overheat. Check the extension cord for damage at regular intervals. Replace damaged extension cords.

Recommended minimum conductor cross section and max. cable lengths

Conductor cross section	1.5 mm ²	2.0 mm ²	2.5 mm ²	3.5 mm ²
Mains voltage 100V		30 m		50 m
Mains voltage 110-120 V	20 m	30 m	40 m	
Mains voltage 220-240 V	50 m		100 m	

Do not use extension cords with 1.25 mm² conductor cross section.

2.13 Using extension cords outdoors

When working outdoors, use only extension cords that are approved and correspondingly marked for this application.

2.14 Using a generator or transformer

This tool may be powered by a generator or transformer when the following conditions are fulfilled: AC voltage and power output of at least 2,600 W, operating voltage must be within +5% and -15% of the rated voltage at all times, frequency must be in the 50 – 60 Hz range and never above 65 Hz, and the unit must be equipped with automatic voltage regulation and starting boost.

Never operate other power tools or appliances from the generator or transformer at the same time. Switching other power tools or appliances on and off may cause undervoltage and / or overvoltage peaks, resulting in damage to the power tool.

3. Insert tools, accessories

Insert tools and accessories for the TE 30, TE 30-AVR, TE 30-C and TE 30-M

Chuck	TE-C (SDS Plus)
Chuck	TE-T (SDS Top)
Hammer drill bits	Ø 5...25 mm
TE-C percussion core bits	Ø 66...90 mm
TE-T percussion core bits	Ø 50...90 mm
TE-C forming and installation drill bits	Ø 10...35 mm
Anchor-setting tools	TE-C or TE-T connection end
Quick-release chuck for wood and metal drill bits	For smooth or hex. shank
Wood drill bits	Ø 5...25 mm
Metal drill bits	Ø Max. 13 mm

en

Insert tools for the TE 30-C-AVR and TE 30-M-AVR

Pointed chisels	TE-C or TE-T connection end
Flat chisel	TE-C or TE-T connection end
Shaped chisels	TE-C or TE-T connection end

Insert tools and accessories for the TE -C-AVR and TE 30-M-AVR

TE-C lightweight percussion core bits	Ø 25...68 mm
Multipurpose hole saws	Ø 35...105 mm, Hex. connection end
Metal drill bits / stepped drill bits	Ø 3...8 mm, (2nd gear) hex. connection end
Metal drill bits / stepped drill bits	Ø 8...13 mm, (1st gear) hex. connection end
Mixing paddles with smooth shank	Ø 80...150 mm, (for mixing non-flammable materials)

TPS Theft Protection System with Company Card, Company Remote and TPS-K key Option, 206999

4. Technical data

Right of technical changes reserved.

NOTE

The power tool is available in various voltage ratings. Please refer to the power tool's type identification plate for details of its rated voltage and rated input power.

Power tool	TE 30 / TE 30-AVR / TE 30-C-AVR	TE 30-M-AVR
Rated power input	850 W	900 W
Rated current input	Rated voltage 100 V: 9.2 A Rated voltage 110 V: 8.3 A Rated voltage 110...127 V: 8.3 A Rated voltage 220 V: 4.2 A Rated voltage 230 V: 4.0 A Rated voltage 240 V: 3.8 A	Rated voltage 100 V: 10.4 A Rated voltage 110 V: 9.6 A Rated voltage 110...127 V: 9.6 A Rated voltage 220 V: 5.4 A Rated voltage 230 V: 5.3 A Rated voltage 240 V: 5.1 A
Mains frequency	50...60 Hz	50...60 Hz

Power tool	TE 30	TE 30-AVR	TE 30-C-AVR	TE 30-M-AVR
Weight in accordance with EPTA procedure 01/2003	4.0 kg	4.2 kg	4.2 kg	4.4 kg
Dimensions (L x W x H)	359 mm x 93 mm x 213 mm	379 mm x 93 mm x 213 mm	379 mm x 93 mm x 213 mm	379 mm x 93 mm x 213 mm
Drilling speed without hammering 2				1,100/min
Drilling speed without hammering 1	750/min	750/min	750/min	750/min
Hammer drilling speed	750/min	750/min	750/min	750/min
Single impact energy	3.3 J	3.3 J	3.3 J	3.3 J

NOTE

The vibration emission level given in this information sheet has been measured in accordance with a standardised test given in EN 60745 and may be used to compare one tool with another. It may be used for a preliminary assessment of exposure. The declared vibration emission level represents the main applications of the tool. However if the tool is used for different applications, with different accessories or poorly maintained, the vibration emission may differ. This may significantly increase the exposure level over the total working period. An estimation of the level of exposure to vibration should also take into account the times when the tool is switched off or when it is running but not actually doing the job. This may significantly reduce the exposure level over the total working period. Identify additional safety measures to protect the operator from the effects of vibration such as: maintain the tool and the accessories, keep the hands warm, organisation of work patterns.

Noise and vibration information (measured in accordance with EN 60745):

Typical A-weighted sound power level	101 dB (A)
Typical A-weighted emission sound pressure level	90 dB (A)
Uncertainty for the given sound level as per EN 60745	3 dB (A)

Additional information in accordance with EN 60745

Triaxial vibration value for the TE 30 (vibration vector sum)	measured in accordance with EN 60745-2-6
Hammer drilling in concrete, $a_{h, HD}$	16.5 m/s ²
Triaxial vibration value for the TE 30-AVR (vibration vector sum)	measured in accordance with EN 60745-2-6
Hammer drilling in concrete, $a_{h, HD}$	12 m/s ²
Triaxial vibration value TE 30-C-AVR / TE 30-M-AVR (vibration vector sum)	measured in accordance with EN 60745-2-6
Hammer drilling in concrete, $a_{h, HD}$	12 m/s ²
Chiseling, $a_{h, HD}$	11 m/s ²
Uncertainty (K)	1.5 m/s ²

Other information about the power tool

Chuck	TE-C (SDS-plus) / TE-T (SDS Top)
Drilling dia. range in concrete/masonry (hammer drilling)	5...28 mm
Percussion core bits	66...90 mm
Drilling dia. range in wood: solid bits	5...20 mm
Drilling dia. range in metal	Max. 13 mm
Drilling performance in medium-hard concrete	Ø 16 mm: 0 cm ² /min
Protection class as per EN	Protection class II (double insulated) as per EN 60745

en

5. Safety instructions

5.1 General Power Tool Safety Warnings

- a) **WARNING! Read all safety warnings and all instructions.** Failure to follow the warnings and instructions may result in electric shock, fire and/or serious injury. **Save all warnings and instructions for future reference.** The term "power tool" in the warnings refers to your mains-operated (corded) power tool or battery-operated (cordless) power tool.

5.1.1 Work area safety

- a) **Keep work area clean and well lit.** Cluttered or dark areas invite accidents.
- b) **Do not operate power tools in explosive atmospheres, such as in the presence of flammable liquids, gases or dust.** Power tools create sparks which may ignite the dust or fumes.
- c) **Keep children and bystanders away while operating a power tool.** Distractions can cause you to lose control.

5.1.2 Electrical safety

- a) **Power tool plugs must match the outlet. Never modify the plug in any way. Do not use any adapter plugs with earthed (grounded) power tools.** Unmodified plugs and matching outlets will reduce risk of electric shock.
- b) **Avoid body contact with earthed or grounded surfaces, such as pipes, radiators, ranges and refrigerators.** There is an increased risk of electric shock if your body is earthed or grounded.
- c) **Do not expose power tools to rain or wet conditions.** Water entering a power tool will increase the risk of electric shock.
- d) **Do not abuse the cord. Never use the cord for carrying, pulling or unplugging the power tool.**

Keep cord away from heat, oil, sharp edges or moving parts. Damaged or entangled cords increase the risk of electric shock.

- e) **When operating a power tool outdoors, use an extension cord suitable for outdoor use.** Use of a cord suitable for outdoor use reduces the risk of electric shock.
- f) **If operating a power tool in a damp location is unavoidable, use a residual current device (RCD) protected supply.** Use of an RCD reduces the risk of electric shock.

5.1.3 Personal safety

- a) **Stay alert, watch what you are doing and use common sense when operating a power tool. Do not use a power tool while you are tired or under the influence of drugs, alcohol or medication.** A moment of inattention while operating power tools may result in serious personal injury.
- b) **Use personal protective equipment. Always wear eye protection.** Protective equipment such as dust mask, non-skid safety shoes, hard hat, or hearing protection used for appropriate conditions will reduce personal injuries.
- c) **Prevent unintentional starting. Ensure the switch is in the off-position before connecting to power source and/or battery pack, picking up or carrying the tool.** Carrying power tools with your finger on the switch or energising power tools that have the switch on invites accidents.
- d) **Remove any adjusting key or wrench before turning the power tool on.** A wrench or a key left attached to a rotating part of the power tool may result in personal injury.

- e) **Do not overreach. Keep proper footing and balance at all times.** This enables better control of the power tool in unexpected situations.
- f) **Dress properly. Do not wear loose clothing or jewellery. Keep your hair, clothing and gloves away from moving parts.** Loose clothes, jewellery or long hair can be caught in moving parts.
- g) **If devices are provided for the connection of dust extraction and collection facilities, ensure these are connected and properly used.** Use of dust collection can reduce dust-related hazards.

5.1.4 Power tool use and care

- a) **Do not force the power tool. Use the correct power tool for your application.** The correct power tool will do the job better and safer at the rate for which it was designed.
- b) **Do not use the power tool if the switch does not turn it on and off.** Any power tool that cannot be controlled with the switch is dangerous and must be repaired.
- c) **Disconnect the plug from the power source and/or the battery pack from the power tool before making any adjustments, changing accessories, or storing power tools.** Such preventive safety measures reduce the risk of starting the power tool accidentally.
- d) **Store idle power tools out of the reach of children and do not allow persons unfamiliar with the power tool or these instructions to operate the power tool.** Power tools are dangerous in the hands of untrained users.
- e) **Maintain power tools. Check for misalignment or binding of moving parts, breakage of parts and any other condition that may affect the power tool's operation. If damaged, have the power tool repaired before use.** Many accidents are caused by poorly maintained power tools.
- f) **Keep cutting tools sharp and clean.** Properly maintained cutting tools with sharp cutting edges are less likely to bind and are easier to control.
- g) **Use the power tool, accessories and tool bits etc. in accordance with these instructions, taking into account the working conditions and the work to be performed.** Use of the power tool for operations different from those intended could result in a hazardous situation.

5.1.5 Service

- a) **Have your power tool serviced by a qualified repair person using only identical replacement**

parts. This will ensure that the safety of the power tool is maintained.

5.2 Additional safety precautions

5.2.1 Personal safety

- a) **Wear ear protectors when impact drilling.** Exposure to noise can cause hearing loss.
- b) **Use auxiliary handle(s), if supplied with the tool.** Loss of control can cause personal injury.
- c) **Hold power tool by insulated gripping surfaces when performing an operation where the cutting accessory may contact hidden wiring or its own cord.** Cutting accessory contacting a "live" wire may make exposed metal parts of the power tool "live" and could give the operator an electric shock.
- d) **Always hold the power tool securely with both hands on the grips provided. Keep the grips dry, clean and free from oil and grease.**
- e) **Breathing protection must be worn if the power tool is used without a dust removal system for work that creates dust.**
- f) **Improve the blood circulation in your fingers by relaxing your hands and exercising your fingers during breaks between working.**
- g) **Avoid touching rotating parts. Switch the power tool on only after bringing it into position at the workpiece.** Touching rotating parts, especially rotating insert tools, may lead to injury.
- h) **Always lead the supply cord and extension cord away from the power tool to the rear while working.** This helps to avoid tripping over the cord while working.
- i) **Children must be instructed not to play with the appliance.**
- j) **The appliance is not intended for use by children, by debilitated persons or those who have received no instruction or training.**
- k) **Dust from material such as paint containing lead, some wood species, minerals and metal may be harmful. Contact with or inhalation of the dust may cause allergic reactions and/or respiratory diseases to the operator or bystanders. Certain kinds of dust are classified as carcinogenic such as oak and beech dust especially in conjunction with additives for wood conditioning (chromate, wood preservative). Material containing asbestos must only be treated by specialists. Where the use of a dust extraction device is possible it shall be used. To achieve a high level of dust collection, use a suitable vacuum cleaner of the**

type recommended by Hilti for wood dust and/or mineral dust together with this tool. Ensure that the workplace is well ventilated. The use of a dust mask of filter class P2 is recommended. Follow national requirements for the materials you want to work with.

5.2.2 Power tool use and care

- a) **Secure the workpiece. Use clamps or a vice to secure the workpiece.** The workpiece is thus held more securely than by hand and both hands remain free to operate the power tool.
- b) **Check that the insert tools used are compatible with the chuck system and that they are secured in the chuck correctly.**
- c) **Switch the power tool off and unplug the supply cord in the event of a power failure or interruption in the electric supply.** This will prevent accidental restarting when the electric power returns.

5.2.3 Electrical safety



- a) **Before beginning work, check the working area (e.g. using a metal detector) to ensure that no concealed electric cables or gas and water pipes are present.** External metal parts of the power tool may become live, for example, when an electric cable is damaged accidentally. This presents a serious risk of electric shock.
- b) **Check the power tool's supply cord at regular intervals and have it replaced by a qualified specialist if found to be damaged. If the power tool's supply cord is damaged it must be replaced with a specially-prepared supply cord available from Hilti Customer Service. Check extension cords at regular intervals and replace them if found to be damaged. Do not touch the supply cord or extension cord if it is damaged while working. Disconnect the supply cord plug from the power**

outlet. Damaged supply cords or extension cords present a risk of electric shock.

- c) **Dirty or dusty power tools which have been used frequently for work on conductive materials should be checked at regular intervals at a Hilti Service Center.** Under unfavorable circumstances, dampness or dust adhering to the surface of the power tool, especially dust from conductive materials, may present a risk of electric shock.
- d) **When working outdoors with an electric tool check to ensure that the tool is connected to the electric supply by way of a ground fault circuit interrupter (RCD) with a rating of max. 30 mA (tripping current).** Use of a ground fault circuit interrupter reduces the risk of electric shock.
- e) **Use of a ground fault circuit interrupter (RCD residual current device) with a maximum tripping current of 30 mA is recommended.**

5.2.4 Work area safety

- a) **Ensure that the workplace is well lit.**
- b) **Ensure that the workplace is well ventilated.** Exposure to dust at a poorly ventilated workplace may result in damage to the health.
- c) **If the work involves breaking right through, take the appropriate safety measures at the opposite side.** Parts breaking away could fall out and / or fall down and injure other persons.

5.2.5 Personal protective equipment



The user and any other persons in the vicinity must wear suitable eye protection, a hard hat, ear protection, protective gloves and breathing protection while the tool is in use.

en

6. Before use



en

6.1 Fitting the side handle 2

CAUTION

Remove the depth gauge from the side handle in order to avoid injury.

1. Disconnect the supply cord plug from the power outlet.

2. Release the side handle clamping band by turning the handle counterclockwise.
3. Slide the side handle clamping band over the chuck and onto the cylindrical section at the front end of the power tool.
4. Pivot the side handle into the desired position.
5. Secure the side handle by turning the grip clockwise.
6. Check that the clamping band is correctly located in the groove provided.

6.2 Use of extension cords and generators or transformers

Please refer to section 2 "Description".

7. Operation



CAUTION

In the event of the drill bit sticking, the power tool will pivot about its own axis. **Always use the power tool with the side handle fitted and hold it securely with both hands so that the resulting opposing force causes the slip clutch to release in the event of the drill bit sticking. Use clamps or a vice to hold the workpiece securely.**

7.1 Preparing for use

7.1.1 Adjusting the depth gauge 3

1. Release the side handle clamping band by turning the handle counterclockwise.
2. Pivot the side handle into the desired position.
3. Adjust the depth gauge to the desired drilling depth "X".
4. Tighten the side handle securely by turning it clockwise.

7.1.2 Fitting the insert tool 4

1. Disconnect the supply cord plug from the power outlet.
2. Check that the connection end of the insert tool is clean and lightly greased. Clean it and grease it if necessary.

3. Check that the sealing lip of the dust shield is clean and in good condition. Clean the dust shield if necessary or replace it if the sealing lip is damaged.
4. Push the insert tool into the chuck and rotate it while applying slight pressure until it engages in the guide grooves.
5. Push the insert tool further into the chuck until it is heard to engage.
6. Check that the insert tool has engaged correctly by pulling it.

7.1.3 Removing the insert tool 5

CAUTION

Wear protective gloves when changing insert tools as the insert tools get hot during use.

1. Disconnect the supply cord plug from the power outlet.
2. Open the chuck by pulling back the chuck release sleeve.
3. Pull the insert tool out of the chuck.

7.1.4 Removing the chuck 6

CAUTION

Remove the depth gauge from the side handle in order to avoid injury.

1. Disconnect the supply cord plug from the power outlet.

2. Pull the chuck sleeve forward and hold it securely.
3. Remove the chuck by pulling it away from the power tool.

7.1.5 Fitting the chuck

CAUTION

Remove the depth gauge from the side handle in order to avoid injury.

1. Disconnect the supply cord plug from the power outlet.
2. Grip the chuck sleeve, pull it forward and hold it securely in this position.
3. Slide the chuck onto the guide tube from the front and then release the sleeve.
4. Rotate the chuck until it is heard to engage.

7.2 Operation



CAUTION

Working on the material may cause it to splinter. **Wear eye protection and protective gloves. Wear breathing protection if no dust removal system is used.** Splintering material presents a risk of injury to the eyes and body.

CAUTION

The work generates noise. **Wear ear protectors.** Exposure to noise can cause hearing loss.

7.2.1 Unlocking the tool (theft protection system – not available for all versions)

NOTE

Further detailed information on activation and use of the theft protection system can be found in the operating instructions for the theft protection system.



NOTE

If, for example, the electric supply is briefly interrupted due to a power failure or disconnected when moving to a different workplace, the power tool remains ready for operation for approx. 20 minutes. In the event of a longer interruption, the TPS key must be used to unlock the power tool.

1. Plug the supply cord into the power outlet. The yellow theft protection indicator LED blinks. The power tool is now ready to receive the signal from the TPS key.

2. Hold the TPS key against the lock symbol. The power tool is unlocked as soon as the yellow theft protection indicator LED no longer lights.

en

7.2.2 Drilling without hammering

CAUTION

Do not operate the function selector switch while the motor is running.

1. Turn the function selector switch until it engages in the “Drilling without hammering” position (TE 30-M-AVR 1st and 2nd gear).
2. Bring the side handle into the desired position and check that it is fitted correctly and secured.
3. Plug the supply cord into the power outlet.
4. Position the power tool and drill bit at the point where the hole is to be drilled.
5. Press the control switch slowly (drill at a low speed until the drill bit centers itself in the hole).
6. Press the control switch fully to continue drilling with full power.
7. Do not apply excessive pressure. This will not increase the power tool’s drilling performance. Lower pressure extends the life of the insert tool.

7.2.3 Hammer drilling

NOTE

Working at low temperatures: The hammering mechanism works only when the power tool has reached a minimum operating temperature. Bring the tip of the drill bit or chisel into contact with the workpiece and allow the power tool to run under no load until it reaches the minimum operating temperature. If necessary, repeat this procedure until the hammering mechanism begins to operate.

CAUTION

Do not operate the function selector switch while the motor is running.

1. Turn the function selector switch until it engages in the “Hammer drilling” position.
2. Bring the side handle into the desired position and check that it is fitted correctly and secured.
3. Plug the supply cord into the power outlet.
4. Position the power tool and drill bit at the point where the hole is to be drilled.

en

5. Press the control switch slowly (drill at a low speed until the drill bit centers itself in the hole).
6. Press the control switch fully to continue drilling with full power.
7. Do not apply excessive pressure. This will not increase the power tool's hammering performance. Lower pressure extends the life of the insert tool.
8. Reduce drilling speed shortly before breaking through in order to avoid damage to the surface at the rear side.

7.2.4 Chiseling (TE 30-C-AVR, TE 30-M-AVR)

NOTE

The chisel can be adjusted to 12 different positions (in 30° increments). This ensures that flat chisels and shaped chisels can always be set to the optimum working position.

7.2.4.1 Positioning the chisel (TE 30-C-AVR, TE 30-M-AVR)

CAUTION

Do not operate the power tool with the switch set to this position.

1. Turn the function selector switch until it engages in the "Chisel adjustment" position. Do not operate the function selector switch while the motor is running.
2. Bring the side handle into the desired position and check that it is fitted correctly and secured. (The power tool can also be held securely at the grip section of the chuck.)
3. Rotate the chisel to the desired position.

7.2.4.2 Locking the chisel (TE 30-C-AVR, TE 30-M-AVR)

1. Turn the function selector switch until it engages in the "Chiseling" position. Do not operate the function selector switch while the motor is running.

7.2.4.3 Chiseling 9

1. Plug the supply cord into the power outlet.
2. Position the tip of the chisel at the point where chiseling is to begin.
3. Press the control switch fully.

7.2.5 Forward / reverse 10

CAUTION

Do not operate the forward / reverse switch while the motor is running.

1. Turn the forward / reverse switch to the forwards (R) or reverse (L) position.

8. Care and maintenance

CAUTION

Disconnect the supply cord plug from the power outlet.

8.1 Care of insert tools

Clean off dirt and dust deposits adhering to the insert tools and protect them from corrosion by wiping the insert tools from time to time with an oil-soaked rag.

8.2 Care of the power tool

CAUTION

Keep the power tool, especially its grip surfaces, clean and free from oil and grease. Do not use cleaning agents which contain silicone.

The outer casing of the power tool is made from impact-resistant plastic. Sections of the grip are made from a synthetic rubber material.

Never operate the power tool when the ventilation slots are blocked. Clean the ventilation slots carefully using a dry brush. Do not permit foreign objects to enter the interior of the power tool. Clean the outside of the power tool at regular intervals with a slightly damp cloth. Do not use a spray, steam pressure cleaning equipment or running water for cleaning. This may negatively affect the electrical safety of the power tool.

8.3 Maintenance

WARNING

Repairs to the electrical section of the power tool may be carried out only by trained electrical specialists.

Check all external parts of the power tool for damage at regular intervals and check that all controls operate faultlessly. Do not operate the power tool if parts

are damaged or when the controls do not function faultlessly. If necessary, the power tool should be repaired by Hilti Service.

8.4 Checking the power tool after care and maintenance

After carrying out care and maintenance work on the power tool, check that all protective and safety devices are fitted and that they function faultlessly.

en

9. Troubleshooting

Fault	Possible cause	Remedy
The power tool doesn't start.	Interruption in the electric supply.	Plug in another electric appliance and check whether it works.
	The supply cord or plug is defective.	Have it checked by a trained electrical specialist and replaced if necessary.
	The carbon brushes are worn.	Have it checked by a trained electrical specialist and replaced if necessary.
	The control switch is defective.	Have it checked by a trained electrical specialist and replaced if necessary.
The power tool doesn't start and the indicator lamp blinks yellow.	The power tool has not been unlocked (power tools with optional theft protection system).	Use the TPS key to unlock the power tool.
No hammering action.	The power tool is too cold.	Allow the power tool to warm up to the minimum operating temperature. See section: 7.2.3 Hammer drilling 
	The function selector switch is set to "Drilling without hammering".	Set the function selector switch to "Hammer drilling".
The power tool doesn't achieve full power.	The extension cord's conductor cross section is inadequate.	Use an extension cord with an adequate conductor cross section. See section: 6.2 Use of extension cords and generators or transformers
	The control switch is not pressed fully.	Press the control switch as far as it will go.
The drill bit doesn't rotate.	The function selector switch is not engaged or is in the "Chiseling" or "Chisel adjustment" position.	Move the function selector switch to the "Hammer drilling" position when the motor has stopped.
The drill bit can't be released.	The chuck is not pulled back fully.	Pull the chuck back as far as it will go and remove the insert tool.
The drill bit makes no progress.	The forward/reverse switch is set to reverse rotation.	Set the forward/reverse switch to forward rotation.

10. Disposal



en

Most of the materials from which Hilti power tools or appliances are manufactured can be recycled. The materials must be correctly separated before they can be recycled. In many countries, Hilti has already made arrangements for taking back your old power tools or appliances for recycling. Please ask your Hilti customer service department or Hilti representative for further information.



For EC countries only

Disposal of electric tools together with household waste is not permissible.

In observance of European Directive 2002/96/EC on waste electrical and electronic equipment and its implementation in accordance with national law, electric tools that have reached the end of their life must be collected separately and returned to an environmentally compatible recycling facility.

11. Manufacturer's warranty - tools

Hilti warrants that the tool supplied is free of defects in material and workmanship. This warranty is valid so long as the tool is operated and handled correctly, cleaned and serviced properly and in accordance with the Hilti Operating Instructions, and the technical system is maintained. This means that only original Hilti consumables, components and spare parts may be used in the tool.

This warranty provides the free-of-charge repair or replacement of defective parts only over the entire lifespan of the tool. Parts requiring repair or replacement as a result of normal wear and tear are not covered by this warranty.

Additional claims are excluded, unless stringent national rules prohibit such exclusion. In particular, Hilti is not obligated for direct, indirect, incidental or consequential damages, losses or expenses in connection with, or by reason of, the use of, or inability to use the tool for any purpose. Implied warranties of merchantability or fitness for a particular purpose are specifically excluded.

For repair or replacement, send the tool or related parts immediately upon discovery of the defect to the address of the local Hilti marketing organization provided.

This constitutes Hilti's entire obligation with regard to warranty and supersedes all prior or contemporaneous comments and oral or written agreements concerning warranties.

12. EC declaration of conformity

Designation:	Rotary hammer
Type:	TE 30 / TE 30-AVR / TE 30-C-AVR / TE 30-M-AVR
Year of design:	2008

We declare, on our sole responsibility, that this product complies with the following directives and standards: EN 60745-1, EN 60745-2-6, EN 55014-1, EN 55014-2, EN 61000-3-2, EN 61000-3-3, 2004/108/EC, as of 28.12.2009 98/37/EC, as of 29.12.2009 2006/42/EC.

Hilti Corporation



Dietmar Sartor
Head of BA Quality and Process
Management
Business Area Electric Tools & Ac-
cessories
02 2009



Jan Doongaji
Senior Vice President

Business Unit Drilling
and Demolition
02 2009

en



Hilti Corporation

LI-9494 Schaan

Tel.: +423 / 234 21 11

Fax: +423 / 234 29 65

www.hilti.com



402495