

MODEL W1856 12" X 18" VARIABLE-SPEED BENCHTOP WOOD LATHE



OWNER'S MANUAL

(FOR MODELS MANUFACTURED SINCE 02/19)

Phone: (360) 734-3482 • Online Technical Support: techsupport@woodstockint.com

COPYRIGHT © FEBRUARY, 2019 BY WOODSTOCK INTERNATIONAL, INC.
WARNING: NO PORTION OF THIS MANUAL MAY BE REPRODUCED IN ANY SHAPE OR FORM WITHOUT
THE WRITTEN APPROVAL OF WOODSTOCK INTERNATIONAL, INC.

#20187KB Printed in China



WARNING!

This manual provides critical safety instructions on the proper setup, operation, maintenance, and service of this machine/tool. Save this document, refer to it often, and use it to instruct other operators.

Failure to read, understand and follow the instructions in this manual may result in fire or serious personal injury—including amputation, electrocution, or death.

The owner of this machine/tool is solely responsible for its safe use. This responsibility includes but is not limited to proper installation in a safe environment, personnel training and usage authorization, proper inspection and maintenance, manual availability and comprehension, application of safety devices, cutting/sanding/grinding tool integrity, and the usage of personal protective equipment.

The manufacturer will not be held liable for injury or property damage from negligence, improper training, machine modifications or misuse.



WARNING!

Some dust created by power sanding, sawing, grinding, drilling, and other construction activities contains chemicals known to the State of California to cause cancer, birth defects or other reproductive harm. Some examples of these chemicals are:

- Lead from lead-based paints.
- Crystalline silica from bricks, cement and other masonry products.
- Arsenic and chromium from chemically-treated lumber.

Your risk from these exposures varies, depending on how often you do this type of work. To reduce your exposure to these chemicals: Work in a well ventilated area, and work with approved safety equipment, such as those dust masks that are specially designed to filter out microscopic particles.

Contents

INTRODUCTION	2	ACCESSORIES	31
Woodstock Technical Support	2	MAINTENANCE	33
Machine Specifications	3	General	33
Identification	5	Cleaning & Protecting	33
Controls & Components	6	Lubrication	33
SAFETY	7	SERVICE	34
Standard Machinery Safety Instructions	7	General	34
Additional Safety for Wood Lathes	9	Tensioning & Replacing Belt	34
ELECTRICAL	10	Aligning Pulleys.....	36
Circuit Requirements	10	Replacing Brushes	37
Grounding Requirements.....	11	Troubleshooting.....	38
Extension Cords	11	Electrical Safety Instructions.....	40
SETUP	12	Electrical Components	41
Unpacking	12	Wiring Diagram	42
Needed for Setup	12	PARTS	43
Inventory	12	Main	43
Machine Placement	13	Labels & Cosmetics	45
Cleaning Machine.....	13	WARRANTY	49
Bench Mounting.....	14		
Assembly.....	15		
Test Run.....	16		
OPERATIONS	17		
General	17		
Workpiece Inspection.....	18		
Adjusting Tailstock	19		
Adjusting Tool Rest.....	20		
Installing/Removing Headstock Center	21		
Installing/Removing Tailstock Center	22		
Removing/Installing Faceplate	23		
Adjusting Spindle Speeds	24		
Spindle Turning	26		
Faceplate Turning	28		
Sanding/Finishing	29		
Selecting Turning Tools	30		

USE THE QUICK GUIDE PAGE LABELS TO SEARCH OUT INFORMATION FAST!



INTRODUCTION

Woodstock Technical Support

This machine has been specially designed to provide many years of trouble-free service. Close attention to detail, ruggedly built parts and a rigid quality control program assure safe and reliable operation.

Woodstock International, Inc. is committed to customer satisfaction. Our intent with this manual is to include the basic information for safety, setup, operation, maintenance, and service of this product.

We stand behind our machines! In the event that questions arise about your machine, please contact Woodstock International Technical Support at (360) 734-3482 Ext. 2 or send e-mail to: techsupport@woodstockint.com. Our knowledgeable staff will help you troubleshoot problems and process warranty claims.

If you need the latest edition of this manual, you can download it from <http://www.woodstockint.com/manuals>.

If you have comments about this manual, please contact us at:

Woodstock International, Inc.
Attn: Technical Documentation Manager
P.O. Box 2309
Bellingham, WA 98227
Email: manuals@woodstockint.com



! WARNING

READ and understand this entire manual before using this machine. Serious personal injury may occur if safety and operational information is not understood and followed. **DO NOT** risk your safety by not reading!

! WARNING

USE this and other machinery with caution and respect. Always consider safety first, as it applies to your individual working conditions. No list of safety guidelines can be complete—every shop environment is different. Failure to follow guidelines could result in serious personal injury, damage to equipment or poor work results.



MACHINE SPECIFICATIONS



© Woodstock International, Inc. • Phone: (800) 840-8420 • Web: www.shopfox.biz

MODEL W1856 12" X 18" VARIABLE SPEED BENCHTOP WOOD LATHE

Product Dimensions

Weight..... 64 lbs.
 Width (side-to-side) x Depth (front-to-back) x Height..... 37 x 14-1/2 x 16-1/2 in.
 Footprint (Length x Width)..... 30-1/2 x 8 in.

Shipping Dimensions

Type..... Cardboard Box
 Content..... Machine
 Weight..... 71 lbs.
 Length x Width x Height..... 34 x 19 x 13 in.
 Must Ship Upright..... Yes

Electrical

Power Requirement..... 120V, Single-Phase, 60 Hz
 Full-Load Current Rating..... 4.5A
 Minimum Circuit Size..... 15A
 Connection Type..... Cord & Plug
 Power Cord Included..... Yes
 Power Cord Length..... 6 ft.
 Power Cord Gauge..... 18 AWG
 Plug Included..... Yes
 Included Plug Type..... 5-15
 Switch Type..... ON/OFF Paddle Switch w/Removable Key

Motors

Main

Horsepower..... 3/4 HP
 Phase..... Single-Phase
 Amps..... 4.5A
 Speed..... 1000 - 2500 RPM
 Type..... Universal Brush-Type DC Motor
 Power Transfer V-Belt Drive
 Bearings..... Sealed & Permanently Lubricated

Main Specifications

Operation Information

Swing Over Bed..... 12 in.
 Swing Over Tool Rest Base..... 9 in.
 Distance Between Centers..... 18-1/8 in.
 No of Spindle Speeds..... 3
 Spindle Speed Range..... 450 - 1100, 960 - 2400, 1400 - 3500 RPM
 Floor to Center Height..... 14 in.
 Headstock Rotation..... Fixed



Spindle Information

Spindle Taper..... MT#2
 Spindle Thread Size..... 1" x 8 TPI
 Spindle Thread Direction..... Right Hand
 Spindle Bore..... 7/16 in. (11.5mm)
 Type of Included Spindle Center..... Spur and Cupped

Tool Rest Information

Tool Rest Width..... 7-3/4 in.
 Tool Rest Post Diameter..... 1 in.
 Tool Rest Post Length..... 2-5/8 in.
 Tool Rest Base Height..... 1-1/4 in.

Tailstock Information

Tailstock Taper..... MT#2
 Type of Included Tailstock Center..... Spur and Cupped

Construction

Bed..... Hardened and Precision-Ground Cast Iron
 Frame..... Cast Iron
 Base..... Cast Iron
 Headstock..... Aluminum
 Tailstock..... Aluminum
 Paint Type/Finish..... Enamel

Other Related Information

Bed Width..... 4-1/2 in.
 Faceplate Size..... 3-1/8 in.

Other

Country of Origin China
 Warranty 2 Years
 Approximate Assembly & Setup Time 15 min.
 Serial Number Location Machine ID Label
 ISO 9001 Factory No
 Certified by a Nationally Recognized Testing Laboratory (NRTL) No

Features

Digital Spindle RPM Display
 3 Spindle Speed Ranges, Each With Variable Speed
 Convenient Accessory Tool Storage Rack
 Solid Cast-Iron Construction
 Quick Releases on Tool Rest and Tailstock for Easy Adjustment

Identification

Become familiar with the names and locations of the controls and features shown below to better understand the instructions in this manual.

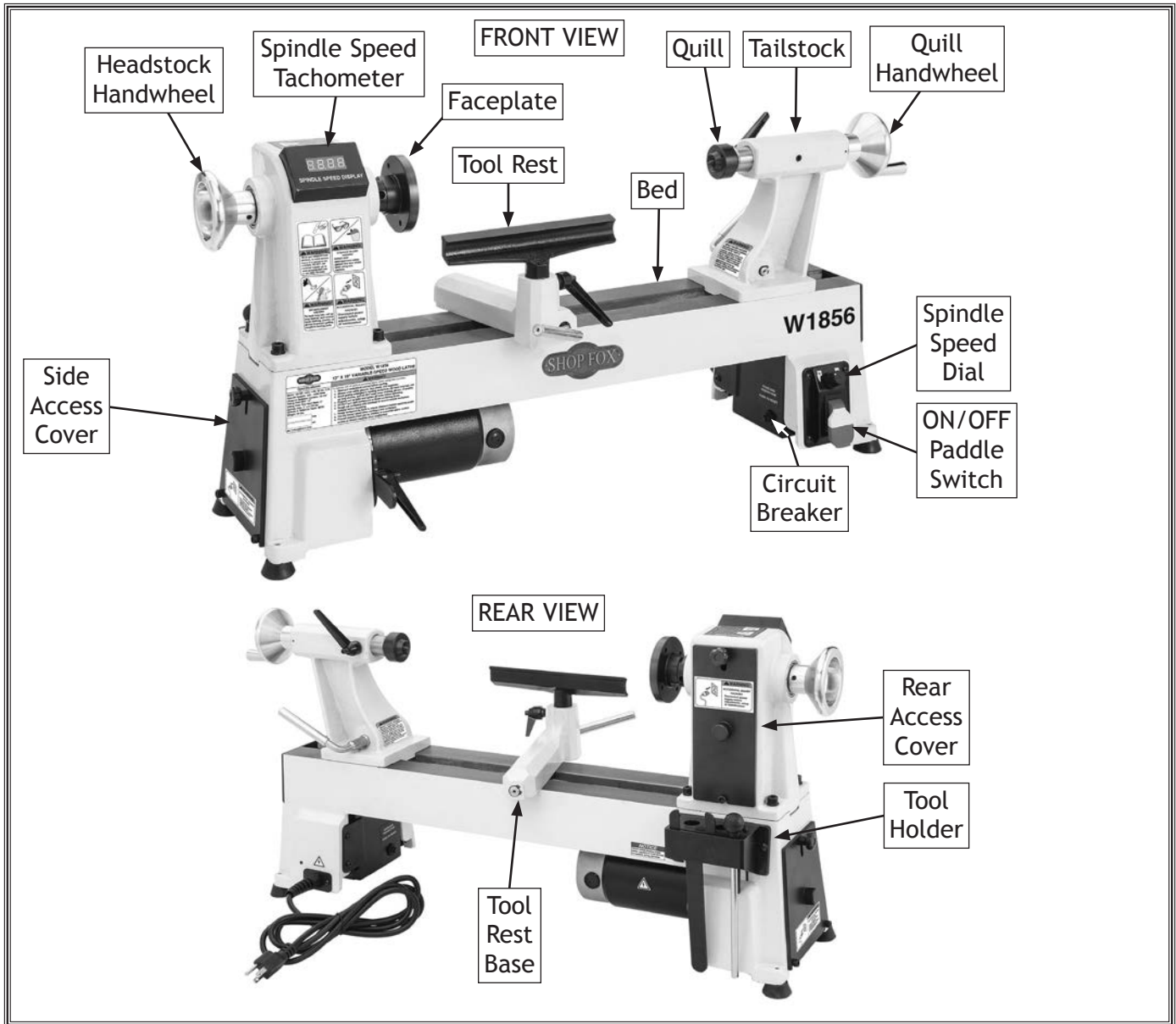

⚠ CAUTION

For Your Own Safety Read Instruction Manual Before Operating Lathe

- a) Wear eye protection.
- b) Do not wear gloves, necktie, or loose clothing.
- c) Tighten all locks before operating.
- d) Rotate workpiece by hand before applying power.
- e) Rough out workpiece before installing on faceplate.
- f) Do not mount split workpiece or one containing knot.
- g) Use lowest speed when starting new workpiece.

Controls & Components

Refer to **Figures 1-4** and the following descriptions to become familiar with the basic controls of this machine. Understanding these items and how they work will help you understand the rest of the manual and stay safe when operating this machine.

Spindle Speed Tachometer: Displays spindle speed in revolutions per minute (RPM).

Belt Tension Lever: Increases or decreases amount of tension on belt.

Belt Tension Lock Handle: Locks belt tension lever in place.

Tool Rest: Provides stable platform for cutting tools.

Tool Rest Lock Handle: Secures tool rest in position.

Tool Rest Base Lock Lever: Secures tool rest base in position along bed.

Circuit Breaker: Resets electrical system in the event of an overload.

Spindle Speed Dial: Adjusts spindle speed from low to high within range governed by pulley belt position.

ON/OFF Paddle Switch: Turns lathe motor ON/OFF to start/stop spindle rotation.

Quill Handwheel: Moves quill toward and away from headstock.

Tailstock Lock Lever: Secures tailstock in position along bed.

Quill Lock Handle: Secures quill in position.

Quill: Holds centers or tooling. Can be moved toward or away from headstock.

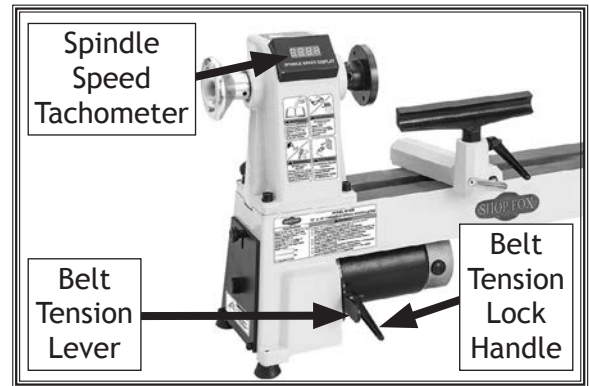

Figure 1. Spindle speed display and belt tension controls.

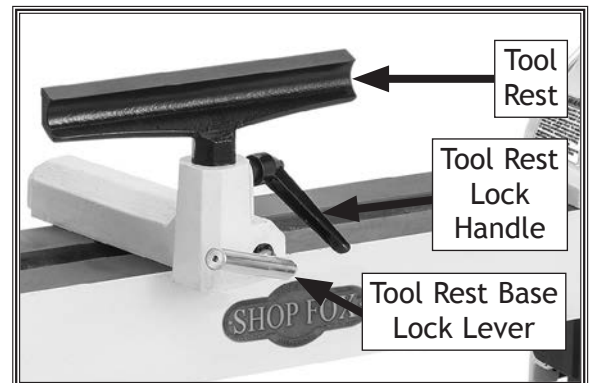

Figure 2. Tool rest controls.

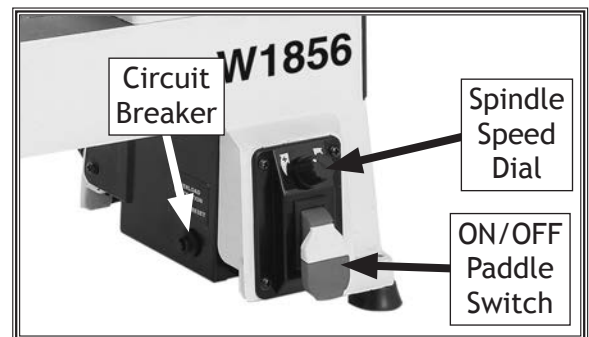

Figure 3. Electrical controls.

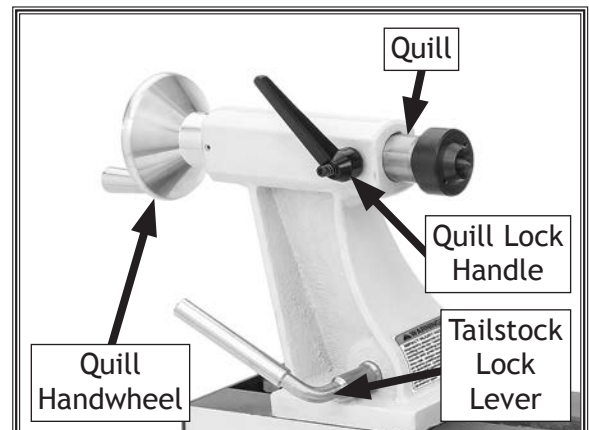

Figure 4. Tailstock controls.

SAFETY

For Your Own Safety, Read Manual Before Operating Machine

The purpose of safety symbols is to attract your attention to possible hazardous conditions. This manual uses a series of symbols and signal words intended to convey the level of importance of the safety messages. The progression of symbols is described below. Remember that safety messages by themselves do not eliminate danger and are not a substitute for proper accident prevention measures—this responsibility is ultimately up to the operator!



Indicates an imminently hazardous situation which, if not avoided, **WILL** result in death or serious injury.



Indicates a potentially hazardous situation which, if not avoided, **COULD** result in death or serious injury.



Indicates a potentially hazardous situation which, if not avoided, **MAY** result in minor or moderate injury.

NOTICE

This symbol is used to alert the user to useful information about proper operation of the equipment or a situation that may cause damage to the machinery.

Standard Machinery Safety Instructions

OWNER'S MANUAL. Read and understand this owner's manual **BEFORE** using machine.

TRAINED OPERATORS ONLY. Untrained operators have a higher risk of being hurt or killed. Only allow trained/supervised people to use this machine. When machine is not being used, disconnect power, remove switch keys, or lock-out machine to prevent unauthorized use—especially around children. Make workshop kid proof!

DANGEROUS ENVIRONMENTS. Do not use machinery in areas that are wet, cluttered, or have poor lighting. Operating machinery in these areas greatly increases the risk of accidents and injury.

MENTAL ALERTNESS REQUIRED. Full mental alertness is required for safe operation of machinery. Never operate under the influence of drugs or alcohol, when tired, or when distracted.

ELECTRICAL EQUIPMENT INJURY RISKS. You can be shocked, burned, or killed by touching live electrical components or improperly grounded machinery. To reduce this risk, only allow an electrician or qualified service personnel to do electrical installation or repair work, and always disconnect power before accessing or exposing electrical equipment.

DISCONNECT POWER FIRST. Always disconnect machine from power supply **BEFORE** making adjustments, changing tooling, or servicing machine. This eliminates the risk of injury from unintended startup or contact with live electrical components.

EYE PROTECTION. Always wear ANSI-approved safety glasses or a face shield when operating or observing machinery to reduce the risk of eye injury or blindness from flying particles. Everyday eyeglasses are not approved safety glasses.

WEARING PROPER APPAREL. Do not wear clothing, apparel, or jewelry that can become entangled in moving parts. Always tie back or cover long hair. Wear non-slip footwear to avoid accidental slips, which could cause loss of workpiece control.

HAZARDOUS DUST. Dust created while using machinery may cause cancer, birth defects, or long-term respiratory damage. Be aware of dust hazards associated with each workpiece material, and always wear a NIOSH-approved respirator to reduce your risk.

HEARING PROTECTION. Always wear hearing protection when operating or observing loud machinery. Extended exposure to this noise without hearing protection can cause permanent hearing loss.

REMOVE ADJUSTING TOOLS. Tools left on machinery can become dangerous projectiles upon startup. Never leave chuck keys, wrenches, or any other tools on machine. Always verify removal before starting!

INTENDED USAGE. Only use machine for its intended purpose—never make modifications without prior approval from Woodstock International. Modifying machine or using it differently than intended will void the warranty and may result in malfunction or mechanical failure that leads to serious personal injury or death!

AWKWARD POSITIONS. Keep proper footing and balance at all times when operating machine. Do not overreach! Avoid awkward hand positions that make workpiece control difficult or increase the risk of accidental injury.

CHILDREN & BYSTANDERS. Keep children and bystanders at a safe distance from the work area. Stop using machine if they become a distraction.

GUARDS & COVERS. Guards and covers reduce accidental contact with moving parts or flying debris—make sure they are properly installed, undamaged, and working correctly.

FORCING MACHINERY. Do not force machine. It will do the job safer and better at the rate for which it was designed.

NEVER STAND ON MACHINE. Serious injury may occur if machine is tipped or if the cutting tool is unintentionally contacted.

STABLE MACHINE. Unexpected movement during operation greatly increases risk of injury or loss of control. Before starting, verify machine is stable and mobile base (if used) is locked.

USE RECOMMENDED ACCESSORIES. Consult this owner's manual or the manufacturer for recommended accessories. Using improper accessories will increase risk of serious injury.

UNATTENDED OPERATION. To reduce the risk of accidental injury, turn machine **OFF** and ensure all moving parts completely stop before walking away. Never leave machine running while unattended.

MAINTAIN WITH CARE. Follow all maintenance instructions and lubrication schedules to keep machine in good working condition. A machine that is improperly maintained could malfunction, leading to serious personal injury or death.

CHECK DAMAGED PARTS. Regularly inspect machine for any condition that may affect safe operation. Immediately repair or replace damaged or mis-adjusted parts before operating machine.

MAINTAIN POWER CORDS. When disconnecting cord-connected machines from power, grab and pull the plug—NOT the cord. Pulling the cord may damage the wires inside, resulting in a short. Do not handle cord/plug with wet hands. Avoid cord damage by keeping it away from heated surfaces, high traffic areas, harsh chemicals, and wet/damp locations.

EXPERIENCING DIFFICULTIES. If at any time you experience difficulties performing the intended operation, stop using the machine! Contact Technical Support at (360) 734-3482.

Additional Safety for Wood Lathes

Serious injury or death can occur from getting entangled in, crushed between, or struck by rotating parts on a lathe! Rotating workpieces can come loose and strike operator or bystanders with deadly force if they are improperly secured, rotated too fast, or are not strong enough for the rotational forces required for turning. Improper tool setup or usage can cause tool kickback or grabbing, resulting in impact injury or entanglement. To reduce the risk of operator (or bystander) injury or death, anyone operating this machine **MUST** completely heed the hazards and warnings below.

VERIFY WORKPIECE INTEGRITY. Verify each workpiece is free of knots, splits, nails, or foreign material to ensure it can safely rotate on spindle without breaking apart or causing tool kickback.

PROPERLY PREPARE WORKPIECE. Before mounting, cut off waste portions to balance workpiece for safe rotation and removal of large edges that can catch on tooling.

SECURE LOCKS. Verify tool rest, headstock, and tailstock are secure before turning lathe **ON**.

SECURE WORKPIECE. Use proven setup techniques and always verify workpiece (and centers/tooling holding workpiece) are well-secured before starting lathe. Only use high-quality fasteners with non-tapered heads for faceplate attachment.

ADJUST TOOL SUPPORT. An improperly supported tool may be grabbed or ejected. Adjust tool rest approximately $\frac{1}{4}$ " away from workpiece and $\frac{1}{8}$ " above workpiece center line to provide proper support for turning tool. Firmly hold turning tool with both hands against tool rest.

REMOVE ADJUSTMENT TOOLS. Remove all chuck keys, wrenches, and adjustment tools before turning lathe **ON**. These items can become deadly projectiles when spindle is started.

WEAR PROPER PPE. Always wear a face shield and safety glasses when operating lathe. Do not wear gloves, necktie or loose clothing. Keep long hair away from rotating spindle.

CHECK CLEARANCES. Before starting spindle, verify workpiece has adequate clearance by hand-rotating it through its entire range of motion.

TEST NEW SETUPS. Test each new setup by starting spindle rotation at lowest speed and standing to side of lathe until workpiece reaches full speed and you can verify safe rotation.

USE CORRECT SPEEDS. Select correct spindle speed for workpiece size, type, shape, and condition. Use low speeds when roughing or when turning large, long, or non-concentric workpieces. Allow spindle to reach full speed before turning.

AVOID TOOL KICKBACK. This occurs when turning tool is grabbed or ejected from workpiece with great force. Commonly caused by poor workpiece selection/preparation, improper tool usage, or improper machine setup or tool rest adjustment.

SAFELY PERFORM ROUGHING. Use correct tool. Take light cuts, use low speeds, and firmly support tool with both hands.

USE SHARP TOOLS. Sharp tools cut with less resistance than dull tools. Using dull tools increases the risk of tool kickback or grabbing.

SAFELY STOPPING ROTATION. Always allow rotating workpiece to stop on its own. Never put hands or another object on workpiece to stop it.

SAFELY MEASURE WORKPIECE. Only measure mounted workpiece after it has completely stopped. Trying to measure a spinning workpiece increases entanglement risk.

SANDING/POLISHING. To reduce entanglement risk, remove tool rest before sanding. Never completely wrap sandpaper around workpiece.

ELECTRICAL

Circuit Requirements

This machine must be connected to the correct size and type of power supply circuit, or fire or electrical damage may occur. Read through this section to determine if an adequate power supply circuit is available. If a correct circuit is not available, a qualified electrician **MUST** install one before you can connect the machine to power.

A power supply circuit includes all electrical equipment between the breaker box or fuse panel in the building and the machine. The power supply circuit used for this machine must be sized to safely handle the full-load current drawn from the machine for an extended period of time. (If this machine is connected to a circuit protected by fuses, use a time delay fuse marked D.)

Full-Load Current Rating

The full-load current rating is the amperage a machine draws at 100% of the rated output power. On machines with multiple motors, this is the amperage drawn by the largest motor or sum of all motors and electrical devices that might operate at one time during normal operations.

Full-Load Current Rating at 120V 4.5 Amps

Circuit Requirements for 120V

This machine is prewired to operate on a power supply circuit that has a verified ground and meets the following requirements:

Circuit Type 110V/120V, 60 Hz, Single-Phase
 Circuit Size 15 Amps
 Plug/Receptacle NEMA 5-15

ELECTRICAL

⚠ WARNING
 The machine must be properly set up before it is safe to operate. **DO NOT** connect this machine to the power source until instructed to do so later in this manual.

⚠ WARNING



Incorrectly wiring or grounding this machine can cause electrocution, fire, or machine damage. To reduce this risk, only an electrician or qualified service personnel should do any required electrical work on this machine.

NOTICE

The circuit requirements listed in this manual apply to a dedicated circuit—where only one machine will be running at a time. If this machine will be connected to a shared circuit where multiple machines will be running at the same time, consult with an electrician to ensure that the circuit is properly sized for safe operation.

Grounding Requirements

This machine **MUST** be grounded. In the event of certain types of malfunctions or breakdowns, grounding provides a path of least resistance for electric current to travel—in order to reduce the risk of electric shock.

Improper connection of the equipment-grounding wire will increase the risk of electric shock. The wire with green insulation (with/without yellow stripes) is the equipment-grounding wire. If repair or replacement of the power cord or plug is necessary, do not connect the equipment-grounding wire to a live (current carrying) terminal.

Check with a qualified electrician or service personnel if you do not understand these grounding requirements, or if you are in doubt about whether the tool is properly grounded. If you ever notice that a cord or plug is damaged or worn, disconnect it from power, and immediately replace it with a new one.

For 120V Connection

This machine is equipped with a power cord with an equipment-grounding wire and NEMA 5-15 grounding plug (see figure). The plug must only be inserted into a matching receptacle that is properly installed and grounded in accordance with local codes and ordinances.

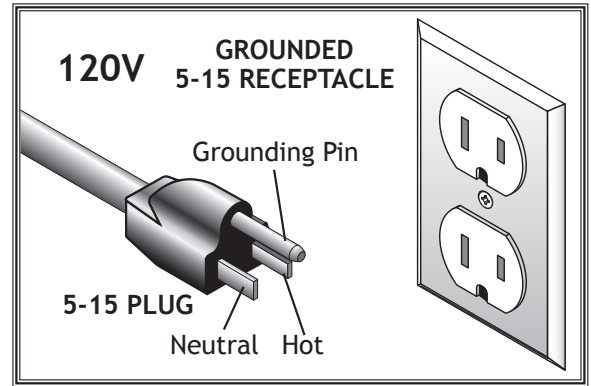
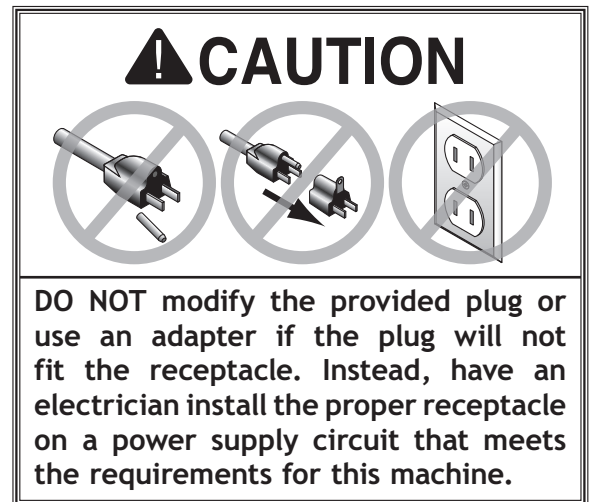

Figure 5. NEMA 5-15 plug & receptacle.



Extension Cords

We do not recommend using an extension cord with this machine. Extension cords cause voltage drop, which may damage electrical components and shorten motor life. Voltage drop increases with longer extension cords and smaller gauge sizes (higher gauge numbers indicate smaller sizes).

Any extension cord used with this machine must contain a ground wire, match the required plug and receptacle, and meet the following requirements:

- Minimum Gauge Size at 120V 16 AWG
- Maximum Length (Shorter is Better) 50 ft.

ELECTRICAL

SETUP

Unpacking

This machine has been carefully packaged for safe transportation. If you notice the machine has been damaged during shipping, please contact your authorized Shop Fox dealer immediately.

Needed for Setup

The following are needed to complete the setup process, but are not included with your machine.

Description	Qty
Additional People	1
Safety Glasses	1 Pair Per Person
Cleaner/Degreaser.....	As Needed
Disposable Shop Rags.....	As Needed
Flat-Head Screwdriver	1

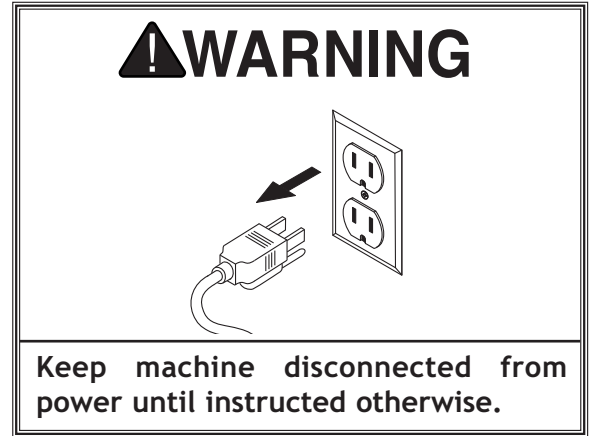

Inventory

The following is a list of items shipped with your machine. Before beginning setup, lay these items out and inventory them.

Note: If you cannot find an item on this list, carefully check around/inside the machine and packaging materials. Often, these items get lost in packaging materials while unpacking or they are pre-installed at the factory.

Box Inventory (Figure 6)	Qty
A. Knockout Rod.....	1
B. Spanner Wrench 32mm	1
C. Hex Wrenches 3, 5mm.....	1 ea.
D. Tool Holder	1
E. Handwheel Handle w/Shoulder Screw	1
F. Spur Center MT#2	1
G. Live Center MT#2.....	1

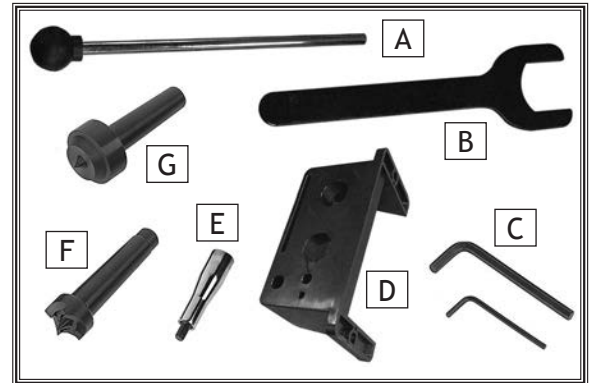

Figure 6. Inventory components.

SETUP

Machine Placement

Workbench Load

Refer to the **Machine Specifications** for the weight and footprint specifications of your machine. Some workbenches may require additional reinforcement to support the weight of the machine and workpiece materials.

Placement Location

Consider anticipated workpiece sizes and additional space needed for auxiliary stands, work tables, or other machinery when establishing a location for this machine in the shop. Below is the minimum amount of space needed for the machine.

	<p>CAUTION INJURY HAZARD! Untrained users can injure themselves with this machine. Restrict access to machine when you are away, especially if it is installed where children are present.</p>
--	---

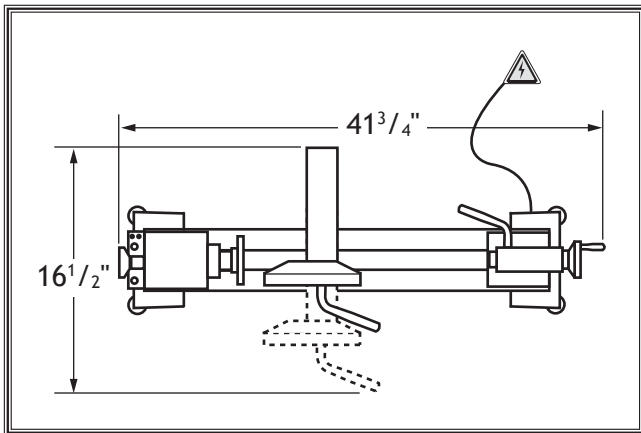

Figure 7. Minimum working clearances.

Cleaning Machine

The unpainted surfaces of your machine are coated with a heavy-duty rust preventative that prevents corrosion during shipment and storage. This rust preventative works extremely well, but it will take a little time to clean.

Be patient and do a thorough job cleaning your machine. The time you spend doing this now will give you a better appreciation for the proper care of your machine's unpainted surfaces.

There are many ways to remove this rust preventative, but the following steps work well in a wide variety of situations. Always follow the manufacturer's instructions with any cleaning product you use and make sure you work in a well-ventilated area to minimize exposure to toxic fumes.

Before cleaning, gather the following:

- Disposable rags
- Cleaner/degreaser (WD•40 works well)
- Safety glasses & disposable gloves
- Plastic paint scraper (optional)

Basic steps for removing rust preventative:

1. Put on safety glasses.
2. Coat the rust preventative with a liberal amount of cleaner/degreaser, then let it soak for 5-10 minutes.
3. Wipe off the surfaces. If your cleaner/degreaser is effective, the rust preventative will wipe off easily. If you have a plastic paint scraper, scrape off as much as you can first, then wipe off the rest with the rag.
4. Repeat **Steps 2-3** as necessary until clean, then coat all unpainted surfaces with a quality metal protectant to prevent rust.

SETUP

<p>NOTICE</p> <p>Avoid chlorine-based solvents, such as acetone or brake parts cleaner, that may damage painted surfaces.</p>
--

Bench Mounting

Number of Mounting Holes..... 4
 Diameter of Mounting Hardware Needed.....6mm

The base of this machine has mounting holes that allow it to be fastened to a workbench or other mounting surface to prevent it from moving during operation and causing accidental injury or damage.

The strongest mounting option is a "Through Mount" (see example) where holes are drilled all the way through the workbench—and hex bolts, washers, and hex nuts are used to secure the machine in place.

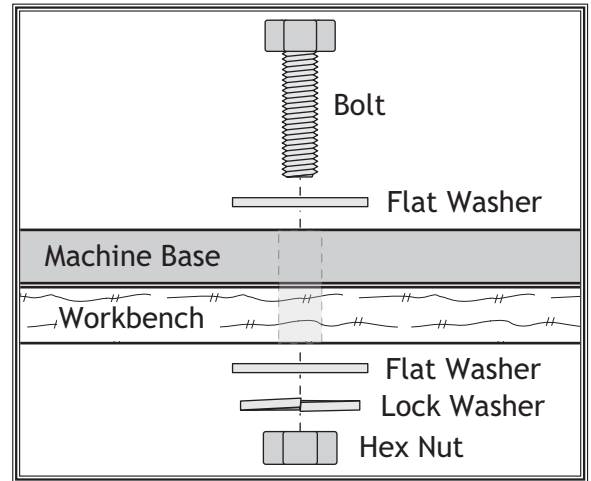

Figure 8. Typical "Through Mount" setup.

Another option is a "Direct Mount" (see example) where the machine is secured directly to the workbench with lag screws and washers.

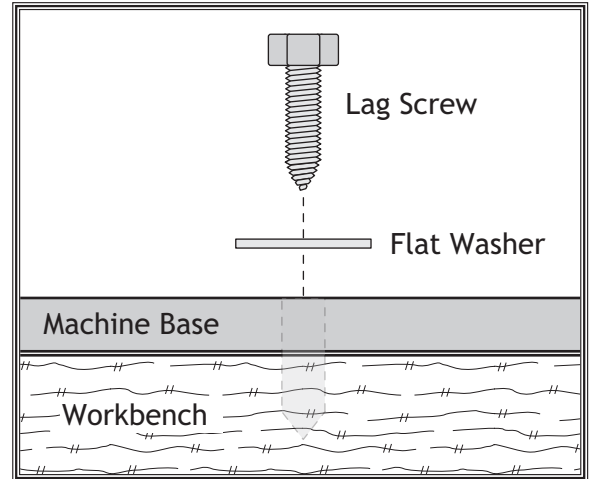

Figure 9. Typical "Direct Mount" setup.

Assembly

Before beginning the assembly process, refer to **Items Needed for Setup** and gather everything you need. Ensure all parts have been properly cleaned of any heavy-duty rust-preventative applied at the factory (if applicable). Be sure to complete all steps in the assembly procedure prior to performing the **Test Run** or connecting the machine to power.

To assemble machine, do these steps:

1. Attach handle to quill handwheel with shoulder screw, then tighten screw (see **Figure 10**).
2. Attach tool holder to back of bed using (2) pre-attached M5-.8 x 12 button head cap screws (see **Figure 11**).

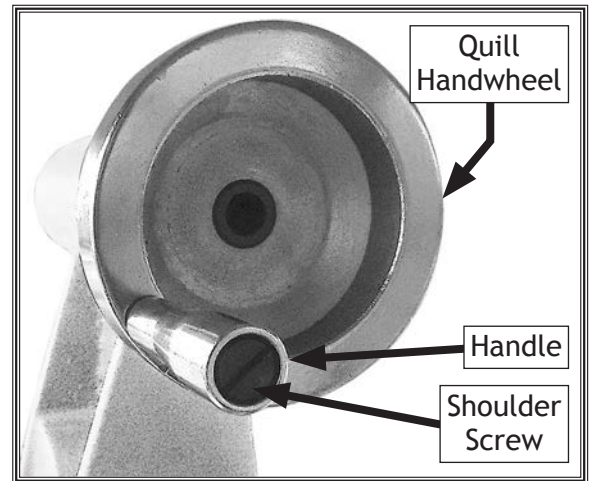

Figure 10. Handle attached to quill handwheel.



Figure 11. Tool holder attached to bed.

SETUP

Test Run

Once assembly is complete, test run the machine to ensure it is properly connected to power and safety components are functioning properly.

If you find an unusual problem during the test run, immediately stop the machine, disconnect it from power, and fix the problem BEFORE operating the machine again. The **Troubleshooting** table in the **SERVICE** section of this manual can help.

The test run consists of verifying the following: 1) The motor powers up and runs correctly, and 2) the safety disabling mechanism on the switch works correctly.

To test run the machine, do these steps:

1. Clear all setup tools away from machine.
2. Connect machine to power supply.
3. Turn machine **ON**, verify motor operation, then turn machine **OFF**.

The motor should run smoothly and without unusual noises.

4. Remove switch disabling key (see example).
5. Try to start machine with paddle switch. The machine should not start.
 - If machine *does not* start, the switch disabling feature is working as designed.
 - If machine *does* start, immediately stop the machine. The switch disabling feature is not working correctly. This safety feature must work properly before proceeding with regular operations. Call Tech Support for help.

⚠ WARNING

Serious injury or death can result from using this machine **BEFORE** understanding its controls and related safety information. **DO NOT** operate, or allow others to operate, machine until the information is understood.

⚠ WARNING

DO NOT start machine until all preceding setup instructions have been performed. Operating an improperly set up machine may result in malfunction or unexpected results that can lead to serious injury, death, or machine/property damage.

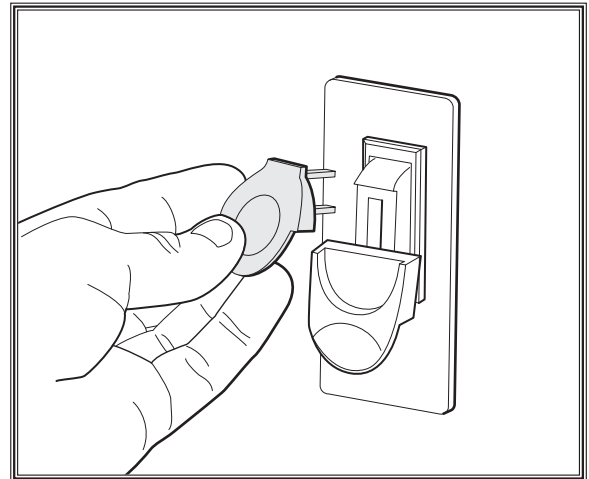

Figure 12. Removing switch key from paddle switch.

SETUP

OPERATIONS

General

This machine will perform many types of operations that are beyond the scope of this manual. Many of these operations can be dangerous or deadly if performed incorrectly.

The instructions in this section are written with the understanding that the operator has the necessary knowledge and skills to operate this machine. If at any time you are experiencing difficulties performing any operation, stop using the machine!

The overview below provides the novice machine operator with a basic understanding of how the machine is used during operation, so the machine controls/components discussed later in this manual are easier to understand. Due to its generic nature, this overview is **NOT** intended to be an instructional guide.

To complete a typical operation, the operator does the following:

1. Examines workpiece to make sure it is suitable for turning. No extreme bows, knots, or cracks should exist.
2. Prepares and trims workpiece with a bandsaw or table saw to make it roughly concentric.
3. Installs workpiece between centers, or attaches it to faceplate or chuck.
4. Adjusts tool rest according to type of operation, and sets minimum clearance between workpiece and lip of tool rest to $\frac{1}{4}$ ".
5. Rotates workpiece by hand to verify spindle and workpiece rotate freely throughout full range of motion.
6. Verifies pulley speed range is set for type of wood and size of workpiece installed.
7. Verifies spindle speed dial is turned fully counterclockwise so spindle does not start in high speed.
8. Puts on safety glasses, face shield, and respirator.

! WARNING

To reduce your risk of serious injury or damage to the machine, read this entire manual **BEFORE** using machine.

! WARNING

Eye injuries or respiratory problems can occur while operating this machine. Wear personal protective equipment to reduce your risk from these hazards.

NOTICE

If you are an inexperienced operator, we strongly recommend that you read books or trade articles, or seek training from an experienced operator of this type of machinery before performing unfamiliar operations. Above all, safety must come first!

9. Turns spindle **ON**, adjusts spindle speed, and carefully begins turning operation, keeping chisel against tool rest entire time it is cutting.
10. Turns spindle **OFF** when cutting operation is complete.

OPERATIONS

Workpiece Inspection

Some workpieces are not safe to turn or may require modification before they are safe to turn. **Before turning, inspect all workpieces for the following:**

- **Workpiece Type:**
This machine is intended for turning natural wood products. Never attempt to turn any composite wood materials, plastics, metal, stone, or rubber workpieces; turning these materials can lead to machine damage or severe injury.
- **Foreign Objects:**
Nails, staples, dirt, rocks and other foreign objects are often embedded in wood. While cutting, these objects can become dislodged and hit the operator, cause tool grab, or break the turning tool, which might then fly apart. Always visually inspect your workpiece for these items. If they can't be removed, DO NOT turn the workpiece.
- **Large/Loose Knots:**
Loose knots can become dislodged during the turning operation. Large knots can cause a workpiece to completely break in half during turning and cause machine damage and injury. Choose workpieces that do not have large/loose knots.
- **Excessive Warping:**
Workpieces with excessive bowing or twisting are unstable and unbalanced. Never turn these workpieces at high speed, or instability will be magnified and the workpiece can be ejected from the lathe causing injury. Only turn concentric workpieces!

Adjusting Tailstock

The tailstock is equipped with a cam-action clamping system to secure it to the lathe bed. When the lever is tightened, a locking plate lifts up underneath the bed and secures the tailstock in place. The tailstock can be positioned anywhere along the lathe bed.

To position tailstock along length of bed, do these steps:

1. Loosen tailstock lock lever and move tailstock to desired position along bed, as shown in **Figure 13**.
2. Retighten tailstock lock lever to secure tailstock to bed.

Note: *The large clamping hex nut underneath the tailstock will require occasional adjusting to ensure proper clamping pressure of the tailstock to the bed. Turn this hex nut in small increments to fine tune the clamping pressure as needed.*

⚠ WARNING

Always operate lathe with tailstock firmly locked to bed. Otherwise, serious personal injury may occur if tailstock moves/shifts during operation.

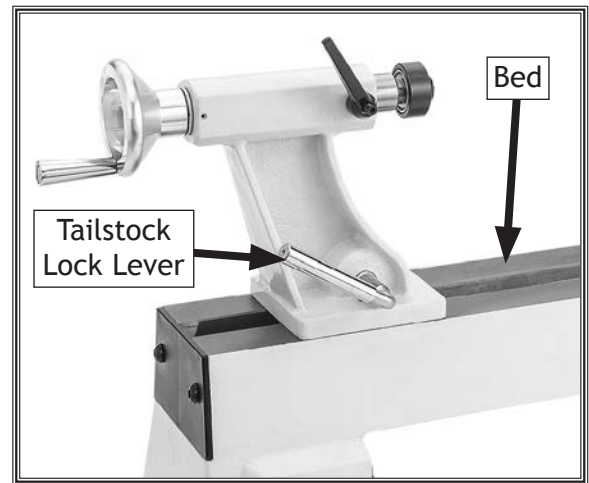

Figure 13. Location of tailstock lock lever.

Adjusting Tool Rest

The tool rest assembly consists of two components: the tool rest base (or banjo) and the tool rest. The tool rest base moves forward/backward and along the length of the lathe bed. The tool rest rotates and moves up and down in the tool rest base. Locks for both components allow you to secure the tool rest in position after making these adjustments.

When adjusting the tool rest, position it as close as possible to the workpiece without actually touching it. This maximizes support where the cutting occurs and minimizes leverage, reducing the risk of injury if a "catch" occurs.

Many woodturners typically set the height of the tool rest $\frac{1}{8}$ " above or below the centerline of the workpiece, depending on their height, the type of tool they're using, and the type of operation they're performing.

As a rule of thumb: For most (spindle) turning operations, the cutting tool should contact the workpiece slightly above centerline. For most inside (bowl) turning operations, the cutting tool should contact the workpiece slightly below centerline.

Keeping all these factors in mind, your main goal when adjusting the tool rest should be providing maximum support for the type of tool being used, in a position that is safe and comfortable for you.

To adjust tool rest, do these steps:

1. Loosen tool rest base lock lever and move tool rest assembly to desired position on lathe bed, as shown in Figure 14.

Note: To maximize support, the tool rest base should always be locked on both sides of the bed. Never pull the tool rest so far back that it is only secured on one side.

2. Retighten tool rest base lock lever to secure tool rest assembly in position.

Note: The large clamping hex nut underneath the tool rest base will require occasional adjusting to ensure proper clamping pressure of the tool rest assembly to the bed. Turn this hex nut in small increments to fine tune the clamping pressure as needed.

⚠ WARNING

Improperly supported or positioned cutting tools can "catch" on workpiece, ejecting tool from your hands with great force. To reduce this risk, always ensure tool rest is properly positioned for each type of operation, cutting tool is firmly supported against tool rest BEFORE cutting, and cutting tool is properly positioned to cut at the correct angle for tool and operation type.

⚠ WARNING

Always operate lathe with tailstock firmly locked to bed. Otherwise, serious personal injury may occur if tailstock moves/shifts during operation.

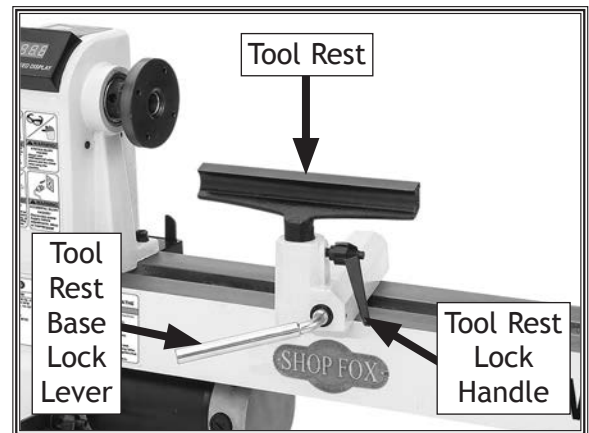

Figure 14. Tool rest controls.

3. Loosen tool rest lock handle (see Figure 14).
4. Position tool rest in desired location.
5. Retighten tool rest lock handle to secure tool rest in position.

Installing/Removing Headstock Center

The included spur center installs in the headstock spindle with an MT#2 tapered fit.

Items Needed	Qty
Heavy Gloves/Clean Rag.....	1
Knockout Rod	1

Installing Headstock Center

1. DISCONNECT MACHINE FROM POWER!
2. Make sure mating surfaces of center and spindle are free of debris and oily substances before inserting center to ensure a good fit and reduce runout.
3. Insert tapered end of center into spindle, and push it in with a quick, firm motion, as shown in **Figure 15**.
4. Make sure center is securely installed by attempting to pull it out by hand. A properly installed center will not pull out easily.

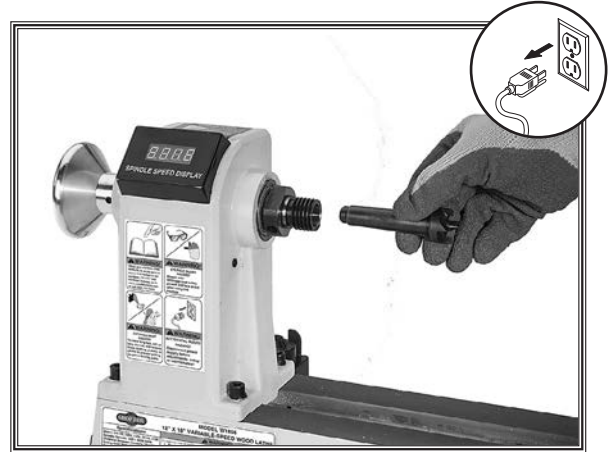

Figure 15. Example of installing center in headstock spindle.

Removing Headstock Center

1. DISCONNECT MACHINE FROM POWER!
2. Hold a clean rag under spindle or wear leather glove to catch center when you remove it.
3. Insert knockout rod through outboard end of spindle and firmly tap back of center, catching it as it falls, as shown in **Figure 16**.

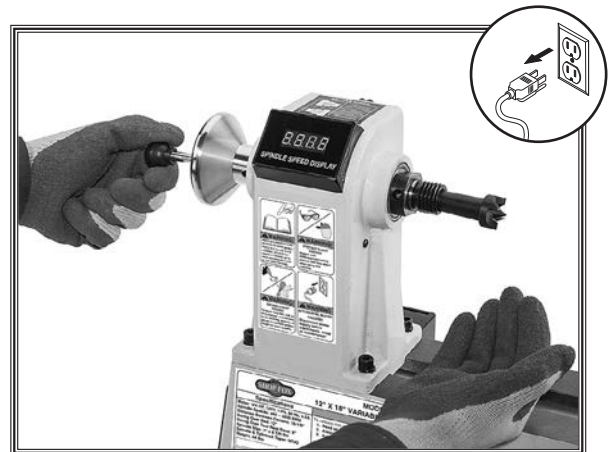

Figure 16. Example of removing headstock center with knockout rod.

OPERATIONS

Installing/Removing Tailstock Center

The included live center installs into the tailstock quill with an MT#2 tapered fit.

Items Needed	Qty
Heavy Gloves/Clean Rag.....	1

Installing Tailstock Center

1. Loosen quill lock handle, and rotate handwheel until quill extends about 1", as shown in **Figure 17**.
2. Make sure mating surfaces of center and quill are free of debris and oily substances before inserting center to ensure a good fit and reduce runout.
3. Firmly insert tapered end of center into tailstock quill, as shown in **Figure 17**.
4. Make sure center is securely installed by attempting to pull it out by hand—a properly installed center will not pull out easily.
5. Secure quill in place by retightening quill-lock handle.

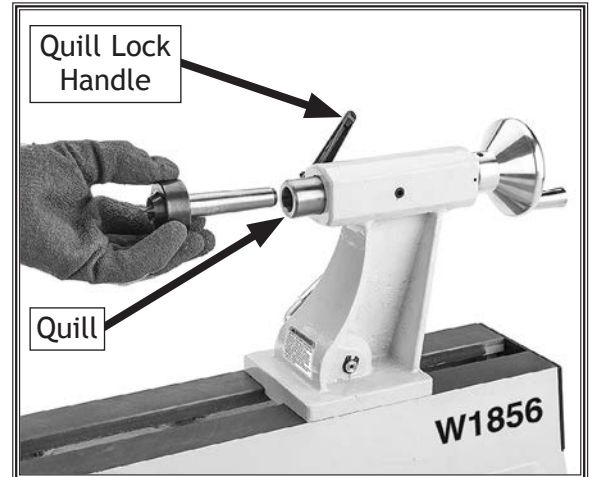

Figure 17. Example of installing center into tailstock quill.

Removing Tailstock Center

1. Loosen quill-lock handle.
2. Hold a clean rag under spindle or wear a glove to catch center when you remove it.
3. Rotate handwheel counterclockwise—tailstock quill will retract back into quill, causing center to be forced out. If this does not work, use knockout rod to remove the center.

Removing/Installing Faceplate

These instructions cover removing and installing the faceplate. To mount a workpiece to your faceplate, refer to **Faceplate Turning** on **Page 28**.

Items Needed	Qty
Open-End Wrench 32mm.....	1
Knockout Rod	1

Removing Faceplate

1. DISCONNECT MACHINE FROM POWER!
2. Put open end of wrench over flats behind faceplate. While holding spindle in place with knockout rod, turn wrench counterclockwise until faceplate is removed (see **Figure 18**).

Note: If the spur center is installed, it will be removed during this process.

Installing Faceplate

1. DISCONNECT MACHINE FROM POWER!
2. While holding spindle in place, thread faceplate clockwise onto spindle shaft until secure against shoulder on spindle shaft.
3. Insert knockout rod into one hole on spindle, then tighten/secure faceplate with open-end wrench (see **Figure 18**).

⚠ WARNING

To prevent faceplate and workpiece separating from spindle during operation, headstock faceplate **MUST** be firmly threaded onto spindle and secured in place. If these instructions are not properly performed, serious personal injury could occur.

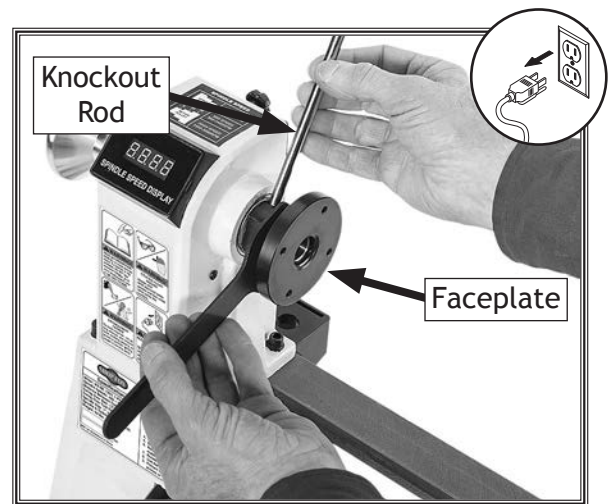

Figure 18. Removing faceplate.

Adjusting Spindle Speeds

Your lathe has three speed ranges for maximum turning options. These ranges are selected by changing belt positions on the motor and spindle pulleys, which are accessed through the rear and side covers on the headstock.

Refer to **Figure 19** for belt positions and speed ranges.

High range (**A**) is best when turning a workpiece where a clean finish is required and only light cuts are made.

Mid range (**B**) is a compromise between high and low ranges.

Low range (**C**), which has more torque, is best when turning a workpiece where a lot of material must be removed and a rough finish does not matter.

Use the speed dial to adjust spindle speed within each range.

⚠ WARNING

Always choose correct spindle speed for your operation. Using wrong speed may lead to workpiece breaking loose or being thrown from lathe at a high rate of speed, causing fatal or severe impact injuries.

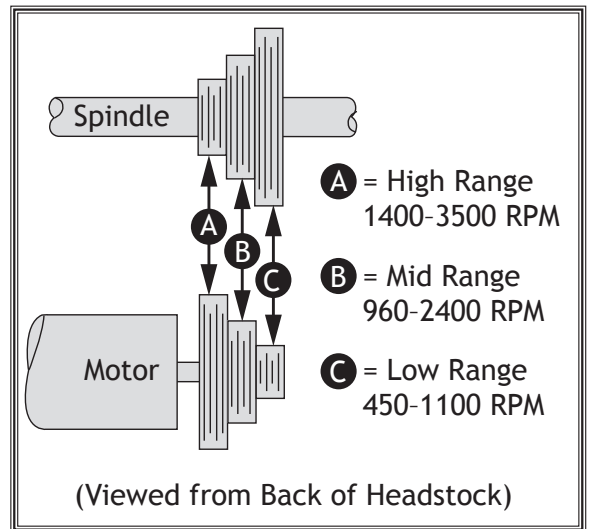

Figure 19. Speed ranges for each belt position.

Refer to the spindle speed recommendation chart (see **Figure 20**) to choose the appropriate RPM for your operation, then choose the speed range that will include the selected RPM.

Work-piece Dia.	Roughing RPM	General Cutting RPM	Finishing RPM
Under 2"	1520	3000	3000
2-4"	760	1600	2480
4-6"	510	1080	1650
6-8"	380	810	1240
8-10"	300	650	1000
10-12"	255	540	830
12-14"	220	460	710

Figure 20. Spindle speed recommendations.

OPERATIONS

To change spindle speeds, do these steps:

1. DISCONNECT MACHINE FROM POWER!
2. Remove side access cover and rear access cover (see Figure 21).

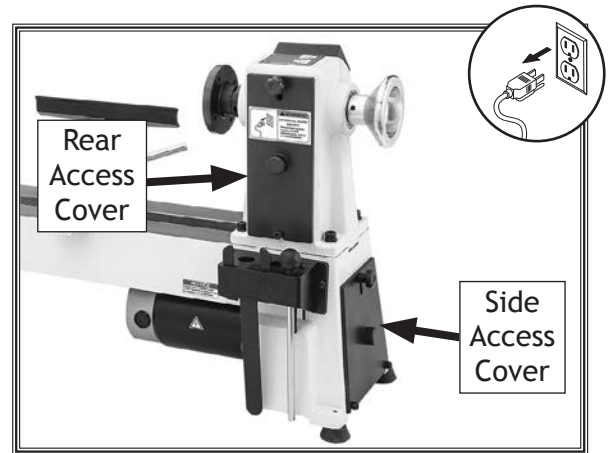

Figure 21. Belt access covers.

3. Loosen belt tension lock handle, then lift belt tension lever all the way up and tighten belt tension lock handle (see Figure 22).
4. Refer to speed range on chart on top of headstock, then move belt to corresponding grooves on motor and spindle pulleys (see Figure 19 on Page 24).
5. Loosen belt tension lock handle and lower motor, then tighten belt tension lock handle.

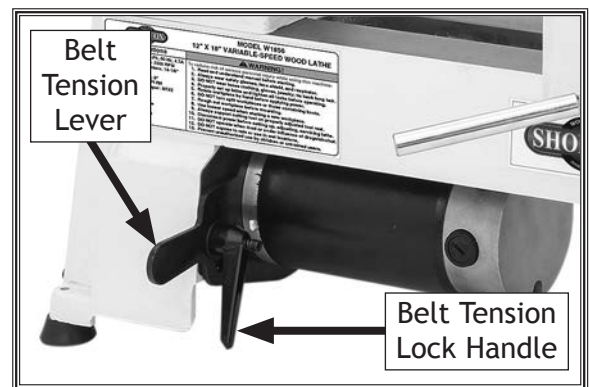

Figure 22. Location of belt tension lever and lock handle.

6. Press belt with moderate pressure in center to check tension. Belt is correctly tensioned when there is approximately 1/2" deflection when pushed as shown in Figure 23.

– If there is more than 1/2" deflection, repeat the tensioning procedure until it is correct. If tension cannot be achieved, see **Replacing Belt** on Page 35.

7. Re-install side access cover and rear access cover.

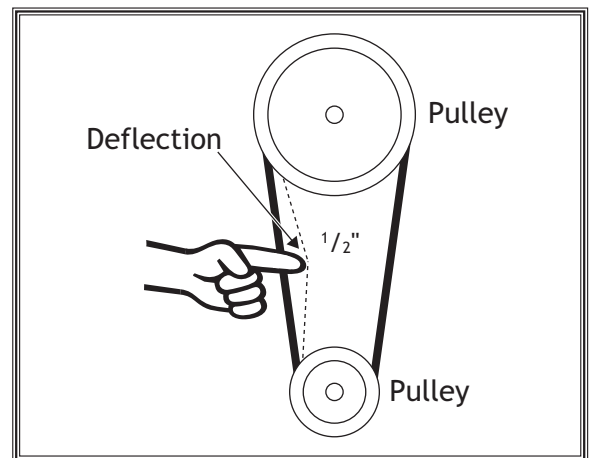

Figure 23. Testing for belt deflection.

Spindle Turning

Spindle turning is the operation performed when a workpiece is mounted between centers in the headstock and tailstock, as shown in **Figure 24**. Bowls, table legs, tool handles, and candlesticks are typical projects where this operation is used.

Items Needed	Qty
Precision Ruler	1
Wood Mallet	1
Drill and Drill Bit $\frac{1}{4}$ "	1
Table Saw/Bandsaw	1

To set up a spindle turning operation, do these steps:

1. Find center point of both ends of your workpiece by drawing diagonal lines from corner to corner across end of workpiece, as shown in **Figure 25**.
2. Make a center mark by using a wood mallet and tapping point of spur center into center of workpiece on both ends.
3. Using a $\frac{1}{4}$ " drill bit, drill a $\frac{1}{4}$ " deep hole at center mark on end of the workpiece to be mounted on headstock spur center.
4. To help embed spur center into workpiece, cut $\frac{1}{8}$ " deep saw kerfs in headstock end of workpiece along diagonal lines marked in **Step 1**.
5. If your workpiece is over 2" x 2", cut corners off workpiece lengthwise to make turning safer and easier (see **Figure 26**).

⚠ WARNING

Damage to your eyes and lungs could result from using this machine without proper protective gear. Always wear safety glasses, a face shield, and a respirator when operating this machine.

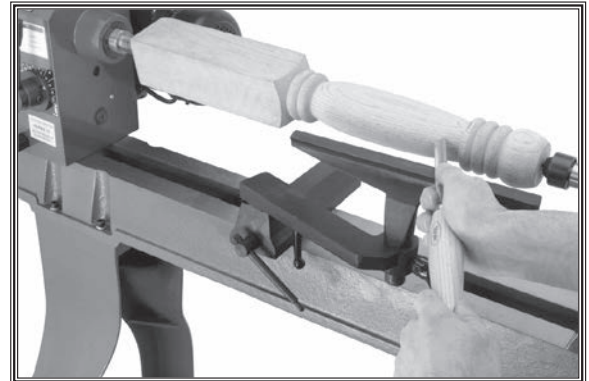

Figure 24. Typical spindle turning operation.

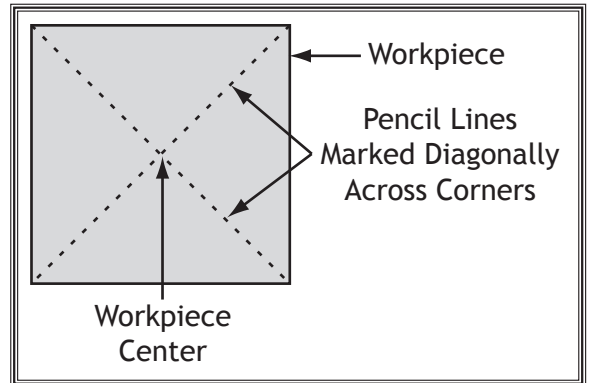

Figure 25. Workpiece marked diagonally from corner to corner to determine center.

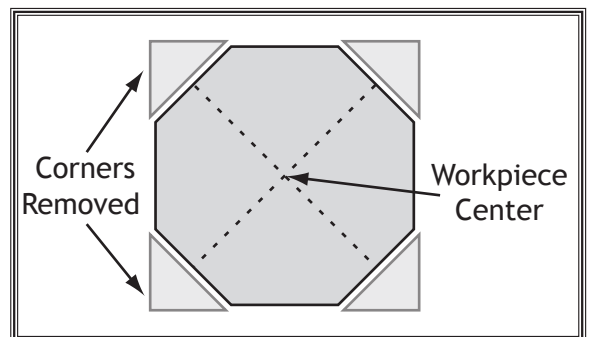

Figure 26. Corners of workpiece removed.

6. Drive spur center into end center mark of workpiece with a wood mallet to embed it at least 1/4" into workpiece, as shown in **Figure 27**.
7. With workpiece still attached, insert spur center into headstock spindle (refer to **Installing/Removing Headstock Center** on **Page 21** for additional instructions).

Note: Use tool rest to support opposite end of workpiece so that workpiece and spur center do not separate during installation.

8. Install live center into tailstock quill and tighten quill-lock handle to lock quill in position (refer to **Page 22** for additional instructions).
9. Slide tailstock toward workpiece until point of live center touches workpiece center mark, then lock tailstock in this position.
10. Loosen quill lock handle and rotate tailstock handwheel to push live center into workpiece at least 1/4".
11. Properly adjust tool rest to workpiece (see **Adjusting Tool Rest** on **Page 20**).
12. Before beginning lathe operation, rotate workpiece by hand to ensure there is safe clearance on all sides.

Spindle Turning Tips

- When turning the lathe **ON**, stand away from the path of the spinning workpiece until the spindle reaches full speed and you can verify that the workpiece will not come loose.
- Use the slowest speed when starting or stopping the lathe.
- Select the right speed for the size of workpiece that you are turning (refer to **Figure 20** on **Page 24**).
- Keep the turning tool on the tool rest the **ENTIRE** time that it is in contact with the workpiece.
- Learn the correct techniques for each tool you will use. If you are unsure about how to use the lathe tools, read books or magazines about lathe techniques, and seek training from experienced and knowledgeable lathe users.

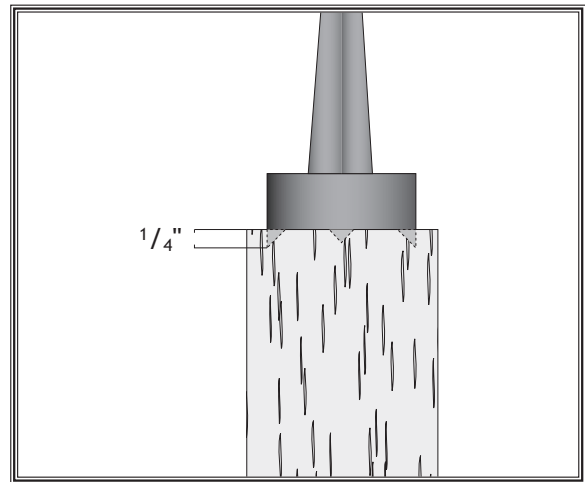

Figure 27. Spur center properly embedded.

! WARNING

Do not press the workpiece too firmly with the tailstock or the bearings will bind and overheat. Do not adjust the tailstock too loosely or the workpiece will spin off the lathe. Use good judgment and care, otherwise serious personal injury could result from the workpiece being ejected at high speeds.

! WARNING

Keep lathe tool resting on tool rest the **ENTIRE** time it is in contact with workpiece or when preparing to make contact between lathe tool and workpiece. Otherwise, spinning workpiece could force lathe tool out of your hands or entangle your hands with workpiece. Failure to heed this warning could result in serious personal injury.

! WARNING

Eye injuries or respiratory problems can occur while operating this machine. Wear personal protective equipment to reduce your risk from these hazards.

OPERATIONS

Faceplate Turning

Faceplate turning is when a workpiece is mounted to the faceplate, which is then mounted to the headstock spindle, as shown in **Figure 28**. This type of turning is usually done with open-faced workpieces like bowls or plates.

Mounting Workpiece on Faceplate

Items Needed	Qty
Precision Ruler	1
Wood Screws.....	1
Drill	1
Table Saw/Bandsaw	1

To mount workpiece on faceplate, do these steps:

1. Mark workpiece center in same manner as described in **Spindle Turning** (see **Page 26**).

Note: *Cut off corners of workpiece to make it as close to "round" as possible, as described in **Spindle Turning, Step 5** (see **Page 26**).*

2. Center faceplate on workpiece and attach it with wood screws (see **Figure 29**).
3. Thread and secure faceplate onto headstock spindle (refer to **Installing Faceplate on Page 23**).

– If wood screws cannot be placed in workpiece, faceplate can be mounted to a backing block attached to workpiece (see **Mounting Workpiece on Backing Block**).

Mounting Workpiece on Backing Block

Items Needed	Qty
Piece of Scrap Wood.....	1
Precision Ruler	1
Drill and Drill Bit 1/4".....	1
Glue	As Needed
Clamp.....	1



Figure 28. Typical faceplate turning operation.



Figure 29. Typical attachment of faceplate to workpiece.

OPERATIONS

NOTICE

Only use screws with non-tapered heads (see **Figure 30**) to attach faceplate to the workpiece. Screws with tapered heads can split faceplate or snap off during operation.

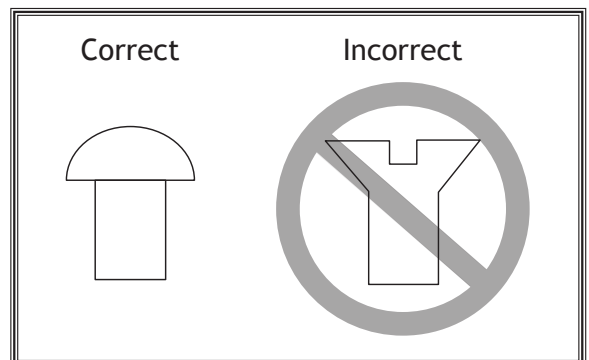

Figure 30. Correct and incorrect screw types.

To mount workpiece on backing block, do these steps:

1. Make backing block from a suitable size piece of scrap wood.

Note: *Faces of backing block must be flat and parallel with each other, or uneven surfaces will cause workpiece to spin eccentrically, causing unnecessary vibration and runout. It is best to mount backing block to faceplate and turn other surface flat prior to mounting.*

2. Locate and mark center of workpiece and backing block.
3. Drill a 1/4" hole through center of backing block.
4. Look through hole in backing block to line up center with workpiece, and then glue and clamp backing block to workpiece.

Note: *Allow glue to cure according to manufacturer's instructions.*

5. Follow Steps 1-3 under **Mounting Workpiece on Faceplate** (see Page 28) to attach backing block to faceplate.

Sanding/Finishing

After the turning operations are complete, the workpiece can be sanded and finished before removing it from the lathe, as shown in Figure 31.

Note: *Whenever sanding or finishing, move the tool rest holder out of the way to increase personal safety and gain adequate working room.*



⚠️ WARNING
Wrapping sandpaper completely around workpiece could pull your hands into moving workpiece and may cause serious injury. Never wrap sandpaper or finishing materials completely around workpiece.

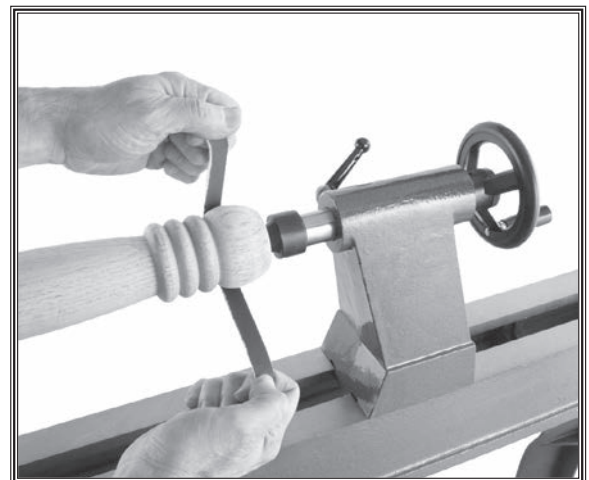

Figure 31. Typical sanding operation.

Selecting Turning Tools

Lathe tools come in a variety of shapes and sizes, and usually fall into five major categories.

- **Gouges**—Mainly used for rough cutting, detail cutting, and cove profiles. The rough gouge is a hollow, double-ground tool with a round nose, and the detail gouge is a hollow, double-ground tool with either a round or pointed nose.
- **Skew Chisel**—A very versatile tool that can be used for planing, squaring, V-cutting, beading, and parting off. The skew chisel is flat, double-ground with one side higher than the other (usually at an angle of 20°-40°).
- **Scrapers**—Typically used where access for other tools is limited, such as hollowing operations. This is a flat, double-ground tool that comes in a variety of profiles (round nose, spear point, square nose, etc.) to match many different contours.
- **Parting Tools**—Used for sizing and cutting off work. This is a flat tool with a sharp pointed nose that may be single- or double-ground.
- **Specialty Tools**—These are the unique, special function tools to aid in hollowing, bowl making, cutting profiles, etc.

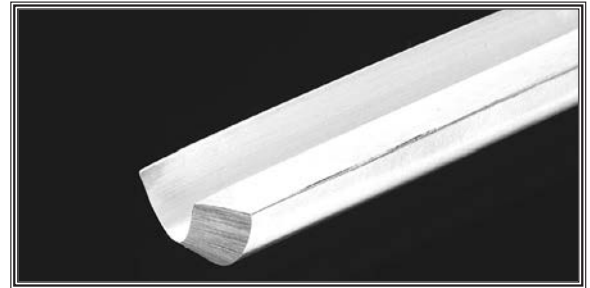

Figure 32. Example of a gouge.

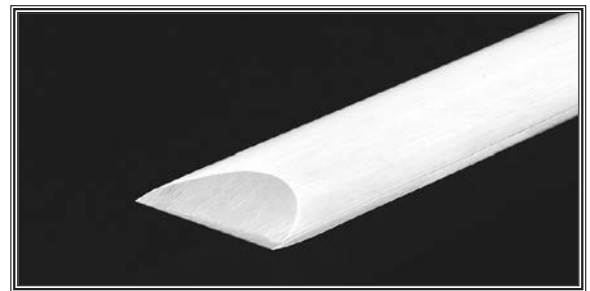

Figure 33. Example of a skew chisel.



Figure 34. Example of a round-nose scraper.

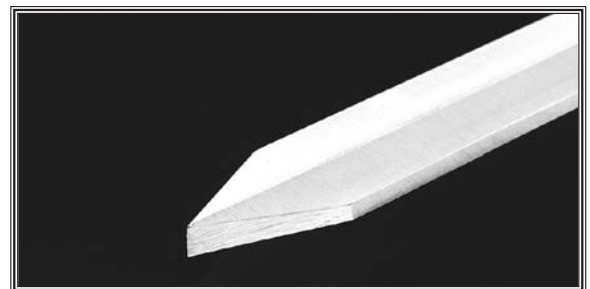

Figure 35. Example of a parting tool.

ACCESSORIES

The following accessories may be available through your local Woodstock International Inc. Dealer. If you do not have a dealer in your area, these products are also available through online dealers. Please call or e-mail Woodstock International Inc. Customer Service to get a current listing of dealers at: 1-800-840-8420 or at sales@woodstockint.com.

The **D4806—1" x 8" Tool Rest Post For Wood Lathes** is designed to mount directly to our D4802, D4803, D4804, and D4805 bowl rests, so you can quickly interchange posts from project to project. Also available in 5" and 6" lengths.

The **D4802, D4803, D4804, D4805 Bowl Rests for Wood Lathes** help you safely navigate those larger turning projects by keeping your chisel point-of-contact close to the rest, thus minimizing vibration for smooth cuts.

- The **D4802** is 9¹/₂" long x 1¹/₄" high, with an 8" radius.
- The **D4803** is 5⁷/₈" x 1¹/₄" high, with a 5" radius.
- The **D4804** is 15¹/₈" long with a 5" and 8" radius.
- The **D4805** is 8³/₈" long with a 3¹/₂" inside radius and a 4¹/₂" outside radius.

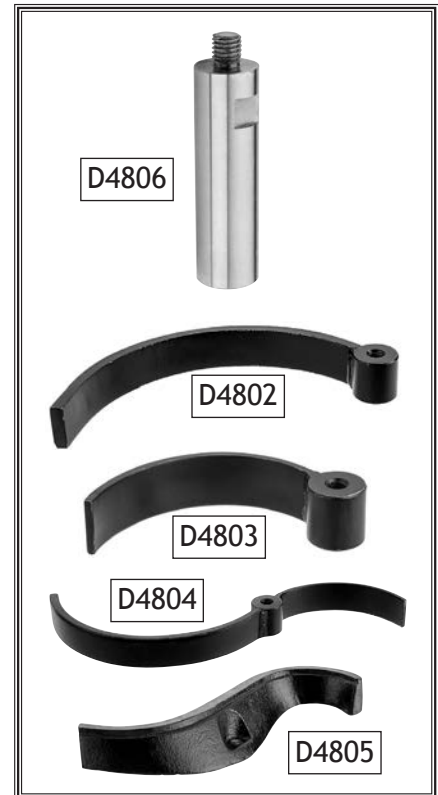

Whether you're just starting out or wish to upgrade your important hand tools, the **D4063—5-Pc. Professional Woodworking Kit** with matching hardwood and brass accents has all the essentials for producing the very best work. This fine set includes a 9" smoothing plane, 6" block plane, 9" try square, 9" marking gauge, 9" bevel gauge, and a fitted wooden case.



Find the center of round or square stock for lathe turning with the handy **D3098—Center Finder**. One side locates a diagonal line on square stock up to 8" x 8" and the other side locates a diagonal line on round stock up to 4¹/₂" in diameter. Marking two opposite diagonal lines determines the center point. It's that simple!

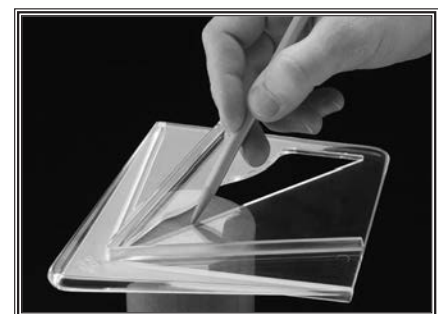

OPERATIONS

The **M1090—6-Pc. Measuring Set** is a must-have set for the serious or amateur hobbyist alike. Made of durable stainless steel, this set will enhance the accuracy of your wood turning dramatically. Includes: 6" inside caliper, 6" outside caliper, 6" straight dividers, 6" scale with pocket clip, fractional equivalent on back, 5" vernier caliper, millimeters scale on back, and 5" depth gauge, millimeters scale on back.

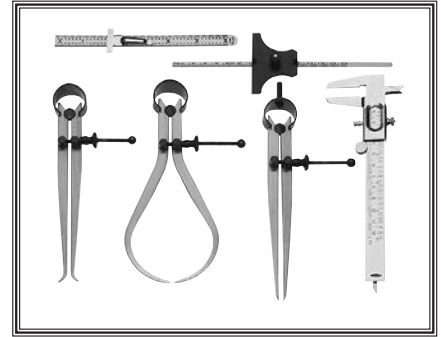

The **D2304 6-Pc. Deluxe HSS Lathe Chisel Set** features beefy ash handles for unsurpassed control, brass ferrules and high speed steel blades. Includes: a 17" long $\frac{13}{16}$ " Parting Tool, $\frac{13}{16}$ " Round Nose and $\frac{3}{8}$ " Gouge, a 19" long 1" Skew, a $\frac{5}{8}$ " Gouge, and a $22\frac{3}{4}$ " long $\frac{3}{8}$ " Gouge.

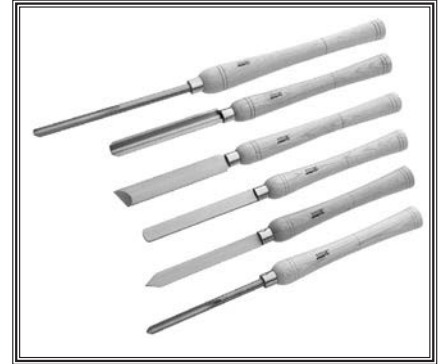

The **D4091—7 pc. Woodworking Kit** includes 9" graduated steel square, $10\frac{1}{2}$ " sliding bevel gauge, rectangular protractor, 10" divider with pencil holder and pencil, 12" double-ended steel ruler, and double-ended scribe.



The **D4103—Mini Lathe Chuck with Arbors** features a 2" diameter, self-centering, 3-jaw, scroll-type chuck with reversible jaws. Includes MT#1 and MT#2 arbors and wrenches.



The **D3640 Tool Table Plus** accommodates larger bench top machines. The table has a butcher-block finish and measures 14" x 40" x $1\frac{1}{4}$ " thick. The wide A-frame stand has a 700 lb. capacity and measures 33" high. Includes stand frame and top.



OPERATIONS

MAINTENANCE

General

For optimum performance from this machine, this maintenance schedule must be strictly followed.

Ongoing

To maintain a low risk of injury and proper machine operation, if you ever observe any of the items below, shut down the machine immediately and fix the problem before continuing operations:

- Loose mounting bolts.
- Damaged center or tooling.
- Worn or damaged wires.
- Loose machine components.
- Any other unsafe condition.

Weekly Maintenance

- Clean off dust buildup.
- Clean and lubricate lathe bed, spindle, and quill.

Monthly Check

- V-belt tension, damage, or wear.

Cleaning & Protecting

Cleaning this lathe is relatively easy. Vacuum excess wood chips and sawdust, and wipe off the remaining dust with a dry cloth. If any resin has built up, use a resin-dissolving cleaner to remove it.

Protect the unpainted cast-iron surfaces by wiping them clean after every use—this ensures moisture from wood dust does not remain on bare metal surfaces. Keep the surfaces rust-free with regular applications of light machine oil.

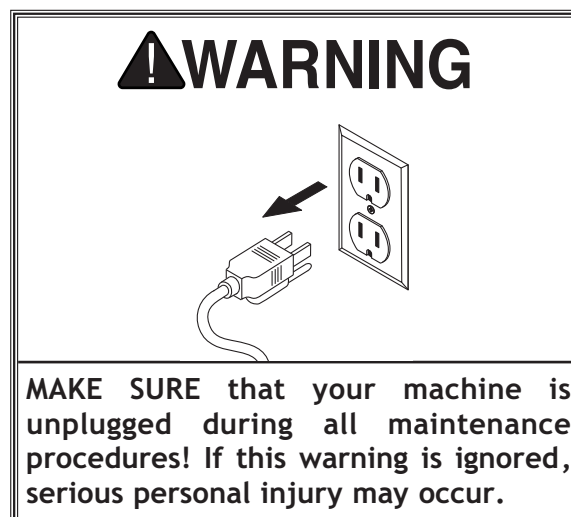

Lubrication

All bearings on this lathe are lubricated and sealed at the factory, and do not need additional lubrication.

Wipe a lightly oiled shop rag on the outside of the headstock spindle. DO NOT allow any oil to get on the inside mating surfaces of the spindle.

Use the tailstock handwheel to extend the quill out to the furthest position and apply a thin coat of white lithium grease to the outside of the quill. DO NOT allow any oil or grease to get on the inside mating surfaces of the quill.

SERVICE

General

This section covers the most common service adjustments or procedures that may need to be made during the life of your machine.

If you require additional machine service not included in this section, please contact Woodstock International Technical Support at (360) 734-3482 or send e-mail to: techsupport@woodstockint.com.

Tensioning & Replacing Belt

The drive belt stretches as the lathe is used. Most of the stretching will occur during the first 16 hours, but may continue with further use. If the lathe loses power while making a cut, the belt may be slipping and need tensioning. If the belt shows signs of excessive wear, or damage, replace it.

Items Needed	Qty
Hex Wrench 3mm	1
Deadblow Hammer	1
Pin Punch, 3/4"	1
Permanent Marker	1

Tensioning Belt

1. DISCONNECT MACHINE FROM POWER!
2. Remove side access cover and rear access cover.
3. Loosen belt-tension lock handle, then push down on belt-tension lever and tighten belt-tension lock handle (see Figure 36).
4. Press belt with moderate pressure in center to check tension. Belt is correctly tensioned when there is approximately 1/2" deflection when pushed as shown in Figure 37.
 - If there is more than 1/2" deflection, repeat the tensioning procedure until it is correct. If tension cannot be achieved, replace belt.
5. Re-install side access cover and rear access cover.

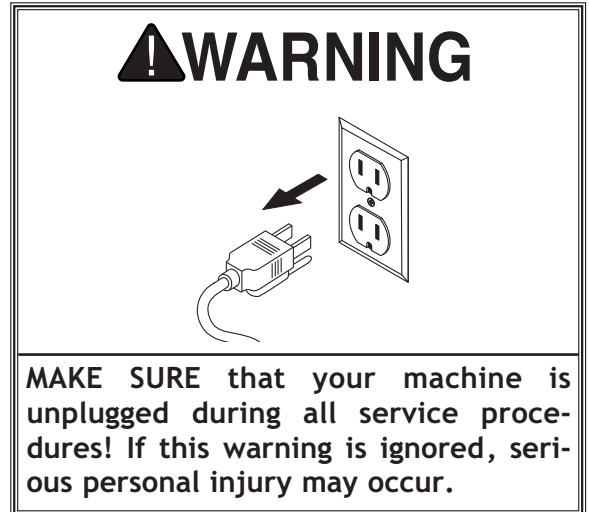

Figure 36. Belt tension controls.

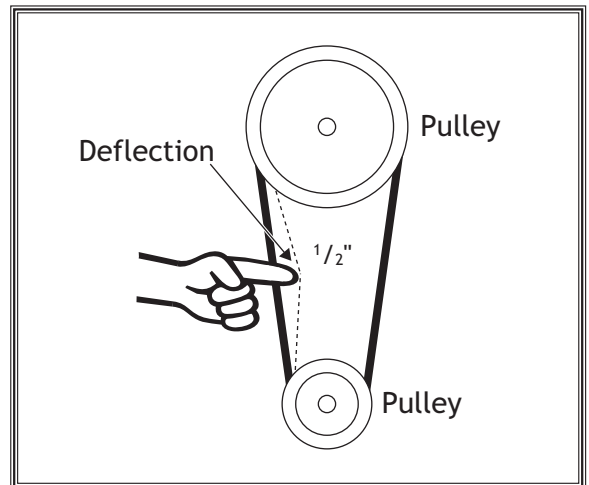

Figure 37. Checking belt deflection.

Replacing Belt

1. DISCONNECT MACHINE FROM POWER!
2. Remove side access cover and rear access cover.
3. Loosen belt-tension lock handle, then lift belt-tension lever and tighten belt-tension lock handle (see **Figure 38**).
4. Loosen (2) set screws on spindle handwheel (see **Figure 39**), then hold faceplate and turn clockwise to remove.
5. Mark location of speed sensor pulley, then loosen set screw (see **Figure 39**).
6. Hold pin punch square against spindle shaft, then hit punch with deadblow hammer to move spindle far enough out of headstock to remove belt (see **Figure 40**).

IMPORTANT: DO NOT use a tapered pin punch on spindle shaft. Take care not to damage spindle threads or lose parts. DO NOT remove spindle pulley.

7. Place new belt over spindle pulley.
 8. Slide spindle back through headstock and into original position.
- Note: A mallet may be required to re-seat spindle into bearing.*
9. Install headstock spindle handwheel and tighten both set screws.
 10. Align speed sensor pulley with marks made in **Step 5**, then tighten set screw.

11. Loosely install belt on innermost or outermost motor pulley position.
12. Follow **Step 4** in the **Tensioning Belt** procedure to set belt tension.
13. Re-install rear access cover and side access cover.



Figure 38. Belt tension controls.

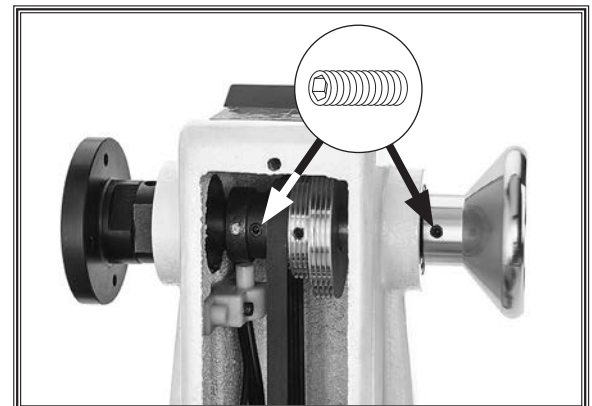

Figure 39. Spindle set screw locations.

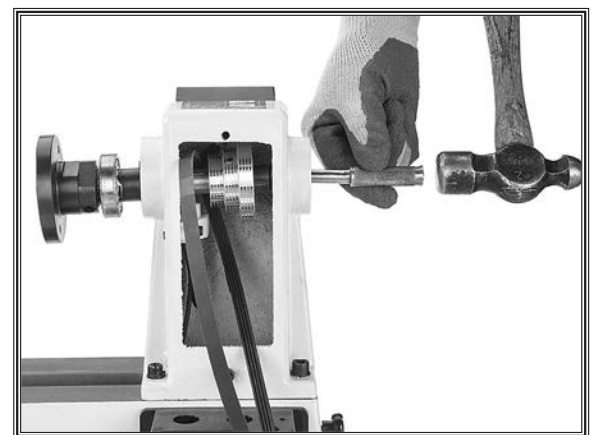

Figure 40. Using punch pin to loosen headstock spindle.

Aligning Pulleys

The motor and spindle pulleys are aligned at the factory and should not require any adjustment. If they become misaligned over time, it is important that they be re-aligned in order to extend belt life and maximize the transfer of power from the motor to the spindle.

Item Needed	Qty
Hex Wrench, 3mm	1

To align motor and spindle pulleys, do these steps:

1. DISCONNECT MACHINE FROM POWER!
2. Remove rear access cover.
3. Loosen set screw on spindle pulley (see **Figure 41**).
4. Slide spindle pulley into alignment with motor pulley.

Note: When pulleys are properly aligned, there should be no unusual or pulsing sounds coming from the belt.

5. Tighten spindle pulley set screw.

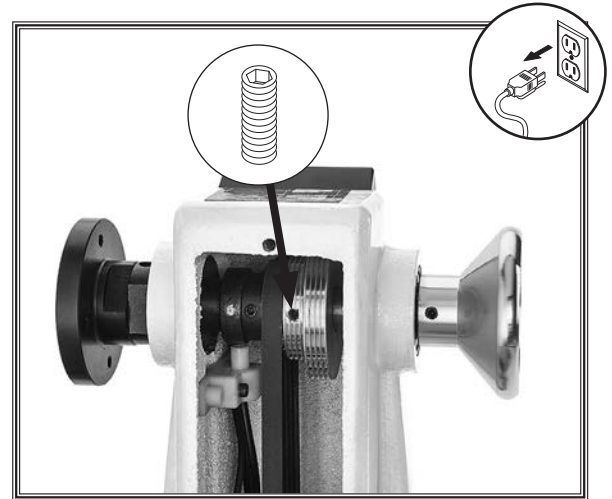

Figure 41. Spindle pulley set screw location.

Replacing Brushes

This machine is equipped with a universal motor that uses a pair of carbon brushes to transmit power. These brushes are considered to be regular "wear items" or "consumables" that will eventually need to be replaced. The frequency of this replacement is directly related to how much the motor is used and how hard it is pushed. These brushes are not covered under warranty.

Replace both brushes at the same time if the motor no longer reaches full power, operates inconsistently, or when the brushes measure less than 1/4" long (new brushes are 5/8" long).

Items Needed	Qty
Flat Head Screwdriver	1
Precision Ruler	1
2-Pc. Brush Kit (X1856105)	1

To replace motor brushes, do these steps:

1. DISCONNECT MACHINE FROM POWER!
2. Remove brush caps on sides of motor (see Figure 42).
3. Remove brushes from motor (see Figure 43).

Note: When brush caps are being removed, a spring will pop out of the motor socket; a spring is firmly attached to each carbon brush. DO NOT separate brush from spring.

4. Use a ruler to measure wear of each carbon brush. If either brush is worn to less than 1/4" in length, replace both brushes.
5. Position each new brush assembly to slide into slots in motor socket. Carefully push spring into motor socket with brush cap, then tighten brush cap.
6. Test run machine.
 - If machine runs properly, you are done.
 - If motor does not start, either new brushes are not correctly aligned in each socket, or there is another problem with motor or wiring. Double-check all wire connections first, then refer to **Troubleshooting on Page 38** for assistance.



Figure 42. Brush cap locations.



Figure 43. Removing brush from motor.

Troubleshooting

The following troubleshooting tables cover common problems that may occur with this machine. If you need replacement parts or additional troubleshooting help, contact our Technical Support.

Note: Before contacting Tech Support, find the machine serial number and manufacture date, and if available, your original purchase receipt. This information is required to properly assist you.

Motor and Electrical

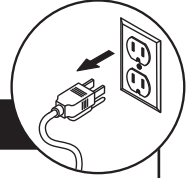

PROBLEM	POSSIBLE CAUSE	CORRECTIVE ACTION
Machine does not start, or power-supply fuse/breaker trips immediately after startup.	<ol style="list-style-type: none"> 1. Switch disabling key removed. 2. Incorrect power supply voltage or circuit size. 3. Machine circuit breaker tripped. 4. Power supply circuit breaker tripped or fuse blown. 5. Wiring broken disconnected, or corroded. 6. Variable-speed potentiometer at fault. 7. ON/OFF switch at fault. 8. Motor brushes worn or at fault. 9. Machine circuit breaker tripped/at fault. 10. Circuit board at fault. 11. Motor at fault. 	<ol style="list-style-type: none"> 1. Install switch disabling key. 2. Ensure correct power supply voltage and circuit size. 3. Reset circuit breaker on switch box. 4. Ensure circuit is sized correctly and free of shorts. Reset circuit breaker or replace fuse. 5. Check/fix broken, disconnected, or corroded wires. 6. Test/replace if at fault. 7. Inspect/replace if at fault. 8. Remove/replace brushes (Page 37). 9. Re-set circuit breaker; inspect/replace if at fault. 10. Inspect/replace if at fault. 11. Test/repair/replace.
Machine stalls or is underpowered.	<ol style="list-style-type: none"> 1. Machine undersized for task. 2. Workpiece material not suitable for machine. 3. Feed rate/cutting speed too fast. 4. Belt slipping. 5. Pulley slipping on shaft. 6. Variable-speed potentiometer at fault. 7. Motor brushes worn or at fault. 8. Circuit board at fault. 9. Motor at fault. 	<ol style="list-style-type: none"> 1. Use sharp chisels; reduce feed rate/depth of cut. 2. Only cut wood/ensure moisture is below 20%. 3. Decrease feed rate/cutting speed (Page 24). 4. Tension/replace belt; ensure pulleys are aligned (Page 36); ensure belt is clean and not damaged. 5. Tighten/replace loose pulley/shaft. 6. Test/replace if at fault. 7. Remove/replace brushes (Page 37). 8. Inspect/replace if at fault. 9. Test/repair/replace.
Machine has vibration or noisy operation.	<ol style="list-style-type: none"> 1. Motor or component loose. 2. Machine sits unevenly on workbench. 3. Belt worn, loose, or misaligned. 4. Pulley loose. 5. Workpiece/faceplate at fault. 6. Motor mount loose/broken. 7. Motor bearings at fault. 	<ol style="list-style-type: none"> 1. Inspect/replace damaged bolts/nuts, and retighten with thread-locking fluid. 2. Adjust rubber feet. 3. Inspect/replace belt (Page 34). Re-align pulleys if necessary (Page 36). 4. Re-align/replace shaft, pulley, set screw, and key. 5. Center workpiece in chuck/faceplate; reduce RPM; replace defective chuck. 6. Tighten/replace. 7. Test by rotating shaft; rotational grinding/loose shaft requires bearing replacement.

Wood Lathe Operation

PROBLEM	POSSIBLE CAUSE	CORRECTIVE ACTION
Bad surface finish.	<ol style="list-style-type: none"> 1. Dull tooling or wrong tool used for task. 2. Tool height is not 1/8" above spindle centerline. 3. Spindle speed is wrong. 4. Excessive vibration. 	<ol style="list-style-type: none"> 1. Sharpen tooling, select correct tool for operation. 2. Adjust tool rest so tool is 1/8" above spindle centerline. 3. Adjust for appropriate spindle speed (Page 24). 4. Troubleshoot possible causes/solutions in this table.
Excessive vibration upon startup (when workpiece is installed).	<ol style="list-style-type: none"> 1. Workpiece is mounted incorrectly. 2. Workpiece warped, out of round, or flawed. 3. Lathe is resting on an uneven surface. 4. Spindle speed too fast for workpiece. 5. Workpiece hitting stationary object. 6. Tailstock or tool rest not securely clamped to lathe bed. 7. Belt pulleys are not properly aligned. 8. Motor mount bolts are loose. 9. Belt is worn or damaged. 10. Spindle bearings are worn or damaged. 	<ol style="list-style-type: none"> 1. Remount workpiece, making sure that centers are embedded in true center of workpiece. 2. Cut workpiece to be concentric, or use a different workpiece. 3. Adjust rubber feet to eliminate wobble. 4. Reduce spindle speed (Page 24). 5. Stop lathe and fix interference problem. 6. Check lock levers and tighten if necessary (Pages 19-20). 7. Align belt pulleys (Page 36). 8. Tighten motor mount bolts. 9. Replace belt (Page 34). 10. Test by rotating shaft; rotational grinding/loose shaft requires bearing replacement.
Chisel grabs or digs into workpiece.	<ol style="list-style-type: none"> 1. Wrong chisel/tool being used. 2. Chisel/tool too dull. 3. Tool rest height not set correctly. 4. Tool rest is set too far from workpiece. 	<ol style="list-style-type: none"> 1. Use correct chisel/tool. 2. Sharpen or replace chisel/tool. 3. Correct tool rest height (Page 20). 4. Move tool rest closer to workpiece.
Tailstock moves under load.	<ol style="list-style-type: none"> 1. Tailstock mounting bolt/hex nut is loose. 2. Bed or clamping surface is excessively oily or greasy. 	<ol style="list-style-type: none"> 1. Tighten mounting bolt/hex nut. 2. Clean bed or clamping surface to remove excess oil/grease.
Spindle lacks turning power or starts up slowly.	<ol style="list-style-type: none"> 1. Belt is slipping. 2. Pulleys loose. 3. Workpiece too heavy for spindle. 	<ol style="list-style-type: none"> 1. Tighten/adjust belt (Page 34). 2. Tighten pulley set screws; re-align/replace shaft, pulley set screws, and key. 3. Remove excess material before remounting; use lighter workpiece.
Quill will not move forward when handwheel is turned.	<ol style="list-style-type: none"> 1. Keyway is not aligned with quill lock lever. 	<ol style="list-style-type: none"> 1. Align quill keyway and quill lock lever and slightly tighten lever to engage keyway.
Spindle speed tachometer doesn't give reading; reading incorrect.	<ol style="list-style-type: none"> 1. Shorted/disconnected wiring/plugs. 2. Variable-speed potentiometer at fault. 3. Spindle speed sensor at fault. 4. Tachometer circuit board at fault. 	<ol style="list-style-type: none"> 1. Inspect wiring connections on circuit boards, sensors, and plugs. Replace/repair as necessary. 2. Test/replace if at fault. 3. Test/replace if at fault. 4. Inspect/replace if at fault.

Electrical Safety Instructions

These pages are current at the time of printing. However, in the spirit of improvement, we may make changes to the electrical systems of future machines. Compare the manufacture date of your machine to the one stated in this manual, and study this section carefully.

If there are differences between your machine and what is shown in this section, call Technical Support at (360) 734-3482 for assistance BEFORE making any changes to the wiring on your machine. An updated wiring diagram may be available. **Note:** Please gather the serial number and manufacture date of your machine before calling. This information can be found on the main machine label.

⚠️ WARNING

SHOCK HAZARD. Working on wiring that is connected to a power source is extremely dangerous. Touching electrified parts will result in personal injury including but not limited to severe burns, electrocution, or death. Disconnect the power from the machine before servicing electrical components!

QUALIFIED ELECTRICIAN. Due to the inherent hazards of electricity, only a qualified electrician should perform wiring tasks on this machine. If you are not a qualified electrician, get help from one before attempting any kind of wiring job.

WIRE CONNECTIONS. All connections must be tight to prevent wires from loosening during machine operation. Double-check all wires disconnected or connected during any wiring task to ensure tight connections.

WIRE/COMPONENT DAMAGE. Damaged wires or components increase the risk of serious personal injury, fire, or machine damage. If you notice that any wires or components are damaged while performing a wiring task, replace those wires or components before completing the task.

MODIFICATIONS. Using aftermarket parts or modifying the wiring beyond what is shown in the diagram may lead to unpredictable results, including serious injury or fire.

MOTOR WIRING. The motor wiring shown in these diagrams is current at the time of printing, but it may not match your machine. Always use the wiring diagram inside the motor junction box.

CAPACITORS/INVERTERS. Some capacitors and power inverters store an electrical charge for up to 10 minutes after being disconnected from the power source. To reduce the risk of being shocked, wait at least this long before working on capacitors.

CIRCUIT REQUIREMENTS. You MUST follow the requirements at the beginning of this manual when connecting your machine to a power source.

EXPERIENCING DIFFICULTIES. If you are experiencing difficulties understanding the information included in this section, contact our Technical Support at (360) 734-3482.

NOTICE

The photos and diagrams included in this section are best viewed in color. You can view these pages in color at www.shopfox.biz.

WIRING DIAGRAM COLOR KEY

BLACK	BLUE	YELLOW	LIGHT BLUE
WHITE	BROWN	YELLOW GREEN	BLUE WHITE
GREEN	GRAY	PURPLE	TUR-QUOISE
RED	ORANGE	PINK	

Electrical Components

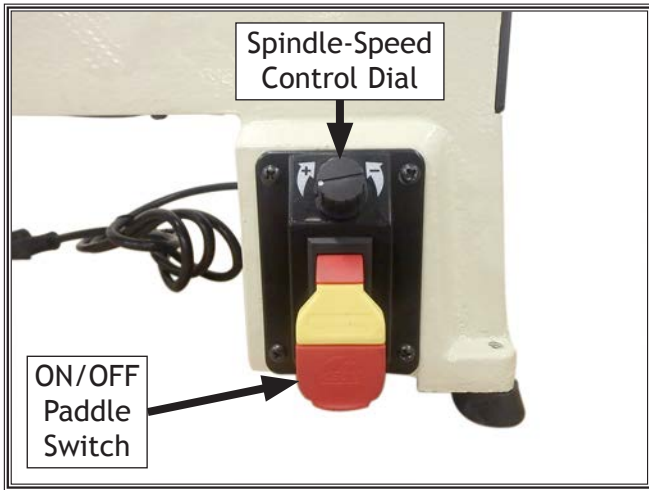

Figure 44. Spindle speed-control dial and ON/OFF paddle switch.



Figure 47. 3/4 HP motor.

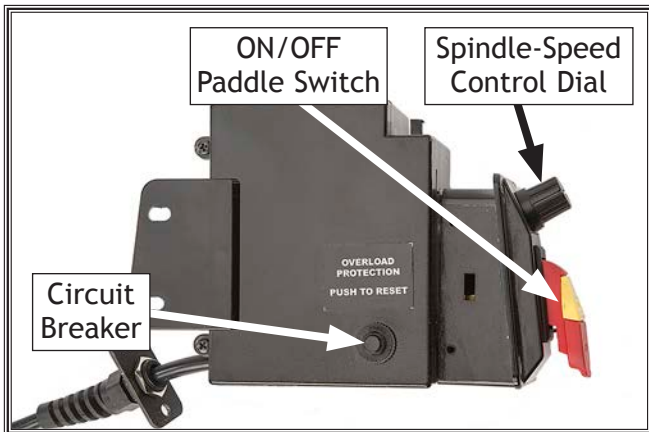

Figure 45. Switch box assembly components.

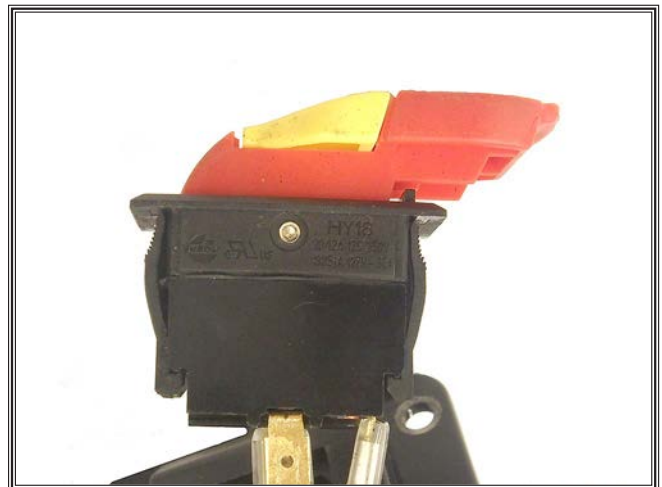

Figure 48. ON/OFF paddle switch.

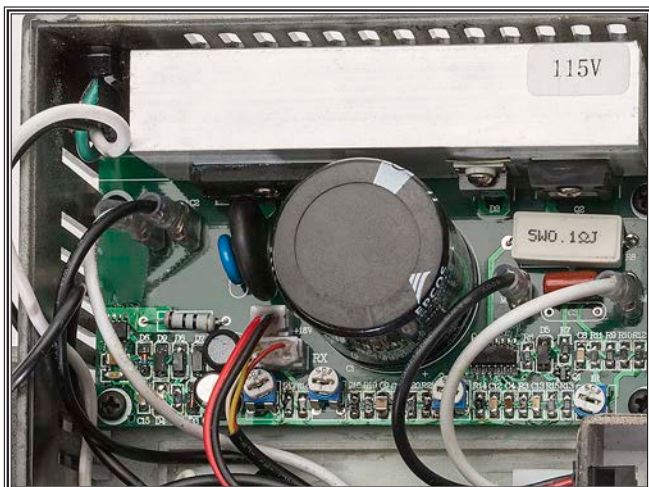

Figure 46. Circuit board.

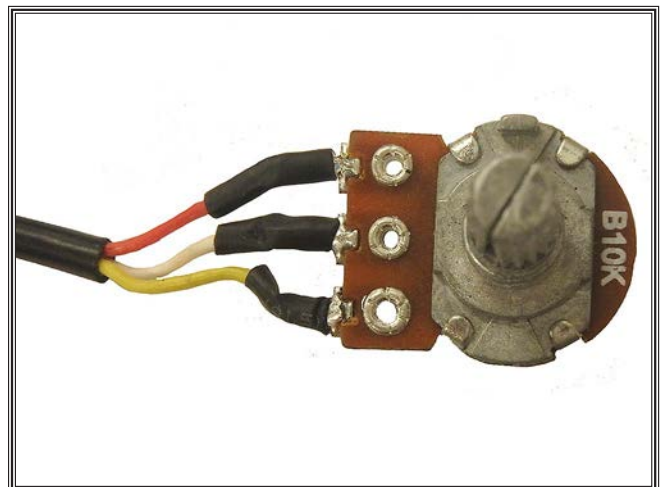
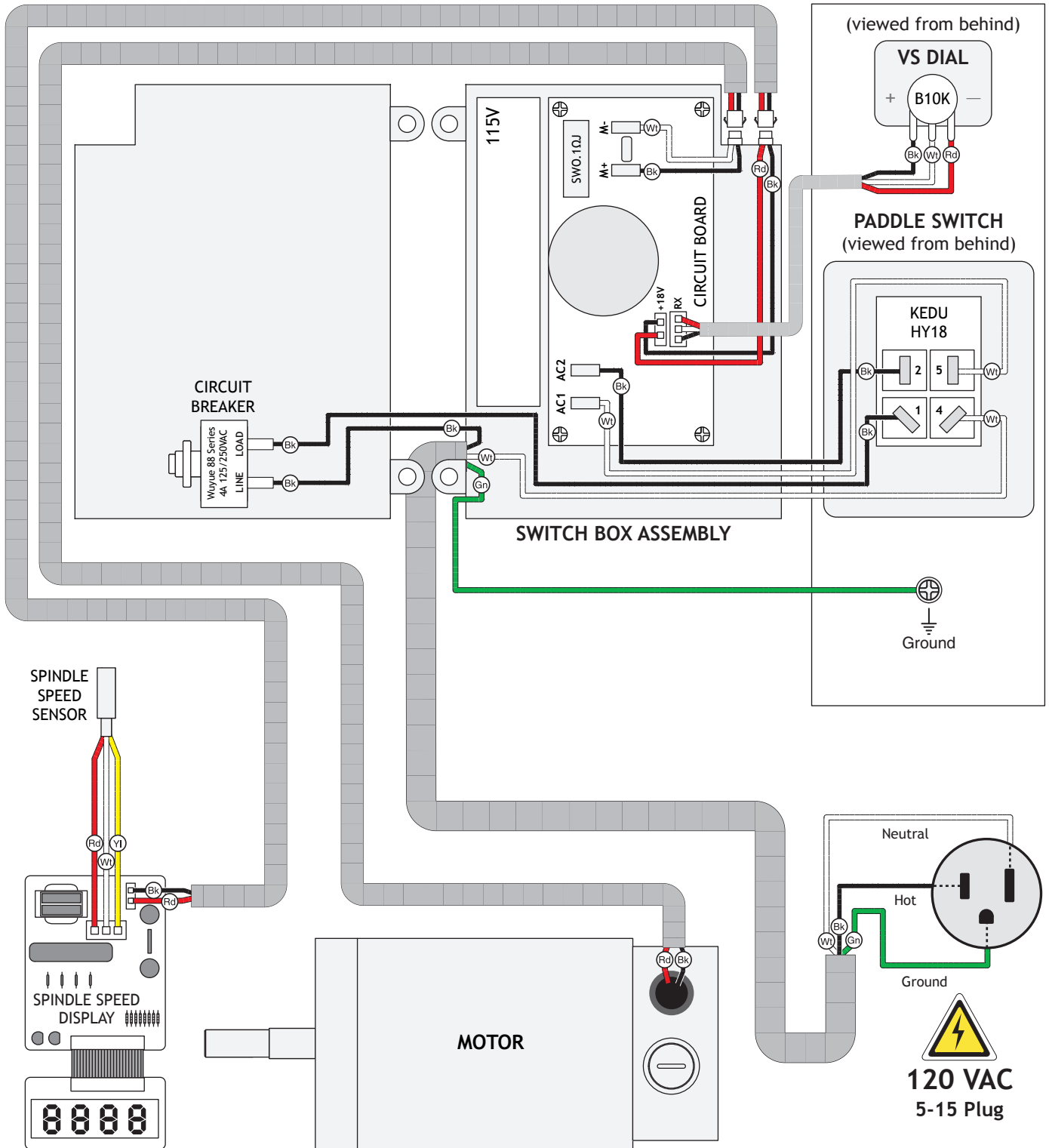

Figure 49. Spindle-speed potentiometer.

Wiring Diagram



SERVICE



PARTS

Main

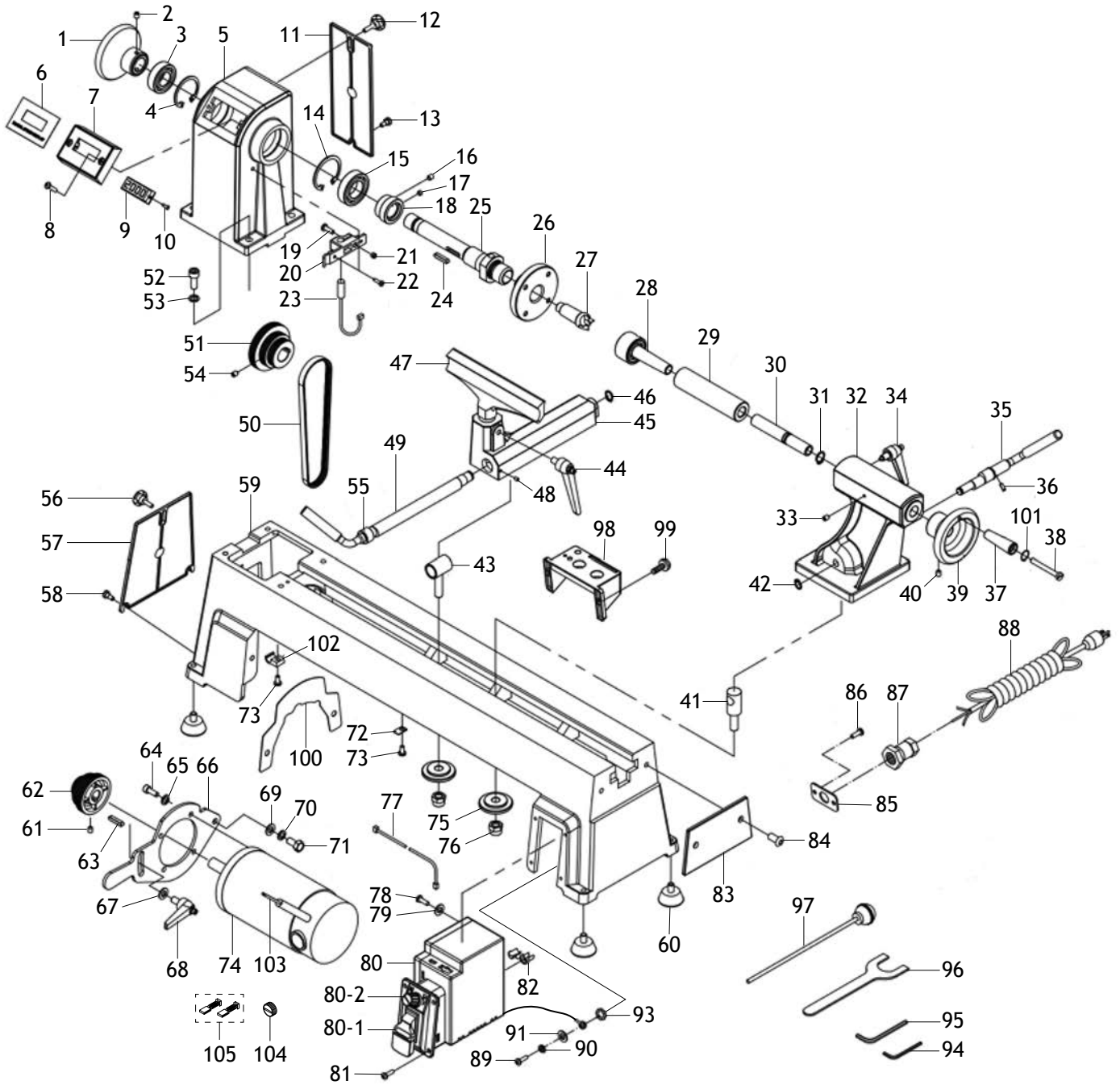

Main Parts List

REF PART #	DESCRIPTION
1	X1856001 HANDWHEEL TYPE-28 79D X 15B-S
2	X1856002 SET SCREW M6-1 X 8
3	X1856003 BALL BEARING 6004ZZ
4	X1856004 INT RETAINING RING 42MM
5	X1856005 HEADSTOCK
6	X1856006 DIGITAL TACHOMETER LABEL
7	X1856007 DIGITAL TACHOMETER MOUNTING BOX
8	X1856008 PHLP HD SCR M5-.8 X 20
9	X1856009 DIGITAL TACHOMETER DISPLAY
10	X1856010 TAP SCREW M3 X 10
11	X1856011 BACK COVER
12	X1856012 KNOB BOLT M6-1 X 15, 4-LOBE, 21D
13	X1856013 CAP SCREW M6-1 X 20
14	X1856014 INT RETAINING RING 47MM
15	X1856015 BALL BEARING 6005ZZ
16	X1856016 SET SCREW M6-1 X 8
17	X1856017 MAGNET
18	X1856018 MAGNET BUSHING
19	X1856019 CAP SCREW M4-.7 X 16
20	X1856020 SPEED SENSOR BRACKET
21	X1856021 HEX NUT M4-.7
22	X1856022 TAP SCREW M3.5 X 12
23	X1856023 SPEED SENSOR
24	X1856024 KEY 5 X 5 X 25
25	X1856025 SPINDLE MT#2
26	X1856026 FACEPLATE 3"
27	X1856027 SPUR CENTER MT#2
28	X1856028 LIVE CENTER MT#2
29	X1856029 TAILSTOCK QUILL
30	X1856030 LEADSCREW
31	X1856031 EXT RETAINING RING 14MM
32	X1856032 TAILSTOCK
33	X1856033 SET SCREW M8-1.25 X 10
34	X1856034 LOCK LEVER M8-1.25 X 10, 65L
35	X1856035 TAILSTOCK LOCK LEVER
36	X1856036 ROLL PIN 3 X 10
37	X1856037 HOLLOW HANDLE 17 X 49, 8D
38	X1856038 SHOULDER SCREW M6-1 X 7, 8 X 47
39	X1856039 HANDWHEEL TYPE-28 79D X 15B-S X M6-1
40	X1856040 SET SCREW M6-1 X 8
41	X1856041 TAILSTOCK CLAMP BOLT M10-1.5 X 28
42	X1856042 EXT RETAINING RING 9MM
43	X1856043 TOOL REST CLAMP BOLT M10-1.5 X 30
44	X1856044 TOOL POST LOCK LEVER
45	X1856045 TOOL REST BASE
46	X1856046 EXT RETAINING RING 12MM
47	X1856047 TOOL REST 7-3/4"W X 5/8" POST
48	X1856048 SET SCREW M4-.7 X 10
49	X1856049 TOOL POST LOCK LEVER
50	X1856050 POLY-V BELT 4V X 27L
51	X1856051 SPINDLE PULLEY
52	X1856052 CAP SCREW M8-1.25 X 25
53	X1856053 LOCK WASHER 8MM

REF PART #	DESCRIPTION
54	X1856054 SET SCREW M6-1 X 8
55	X1856055 BUSHING
56	X1856056 KNOB BOLT M6-1 X 15, 4-LOBE, 21D
57	X1856057 LEFT END COVER
58	X1856058 CAP SCREW M6-1 X 20
59	X1856059 BED
60	X1856060 RUBBER FOOT M8-1.25 X 12, 15 X 34
61	X1856061 SET SCREW M6-1 X 8
62	X1856062 MOTOR PULLEY
63	X1856063 KEY 5 X 5 X 25
64	X1856064 CAP SCREW M6-1 X 15
65	X1856065 LOCK WASHER 6MM
66	X1856066 MOTOR MOUNT PLATE
67	X1856067 FENDER WASHER 8MM
68	X1856068 LOCK LEVER M8-1.25 X 18, 65L
69	X1856069 FLAT WASHER 8MM
70	X1856070 LOCK WASHER 8MM
71	X1856071 HEX BOLT M8-1.25 X 20
72	X1856072 CORD CLAMP
73	X1856073 PHLP HD SCR M5-.8 X 10
74	X1856074 MOTOR 3/4 HP 120V 1-PH
75	X1856075 CLAMP BLOCK
76	X1856076 LOCK NUT M10-1.5
77	X1856077 DIGITAL TACHOMETER CORD 22G 2W 18"
78	X1856078 PHLP HD SCR M5-.8 X 10
79	X1856079 FLAT WASHER 5MM
80	X1856080 SWITCH BOX ASSEMBLY
80-1	X1856080-1 ON/OFF SWITCH KEDU HY18
80-2	X1856080-2 POTENTIOMETER B10K
81	X1856081 PHLP HD SCR M5-.8 X 10
82	X1856082 STRAIN RELIEF TYPE-1 5/16
83	X1856083 END STOP PLATE
84	X1856084 BUTTON HD CAP SCR M8-1.25 X 12
85	X1856085 CORD MOUNTING PLATE
86	X1856086 PHLP HD SCR M5-.8 X 10
87	X1856087 STRAIN RELIEF M16-2
88	X1856088 POWER CORD 18G 3W 72" 5-15P
89	X1856089 PHLP HD SCR M5-.8 X 10
90	X1856090 LOCK WASHER 5MM
91	X1856091 FLAT WASHER 5MM
93	X1856093 EXT TOOTH WASHER 5MM
94	X1856094 HEX WRENCH 3MM
95	X1856095 HEX WRENCH 5MM
96	X1856096 SPANNER WRENCH 32MM
97	X1856097 KNOCKOUT ROD
98	X1856098 TOOL HOLDER
99	X1856099 BUTTON HD CAP SCR M5-.8 X 12
100	X1856100 SEALING PLATE
101	X1856101 O-RING 7.5 X 1.8 KS-6
102	X1856102 CORD CLAMP
103	X1856103 MOTOR CORD 20G 2W 16"
104	X1856104 MOTOR CARBON BRUSH CAP
105	X1856105 MOTOR CARBON BRUSH 2-PC SET

Labels & Cosmetics

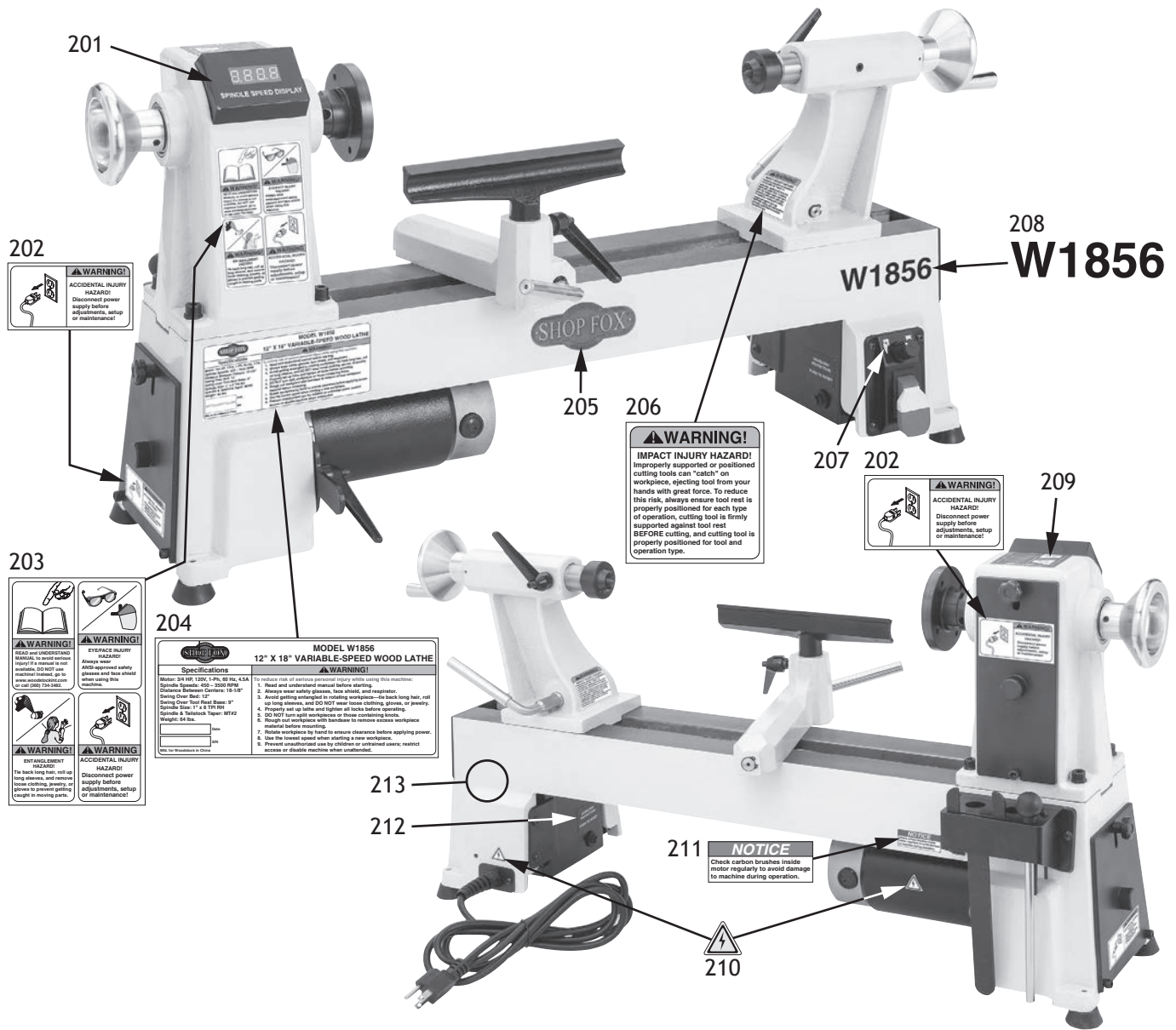

201	X1856201	SPINDLE TACHOMETER LABEL
202	X1856202	DISCONNECT POWER LABEL
203	X1856203	COMBINATION WARNING LABEL
204	X1856204	MACHINE ID LABEL
205	X1856205	SHOP FOX NAMEPLATE SMALL
206	X1856206	IMPACT INJURY WARNING LABEL
207	X1856207	VARIABLE SPINDLE SPEED LABEL

208	X1856208	MODEL NUMBER LABEL
209	X1856209	PULLEY SPEED LABEL
210	X1856210	ELECTRICITY WARNING LABEL
211	X1856211	CHECK BRUSHES NOTICE LABEL
212	X1856212	CIRCUIT BREAKER LABEL
213	X1856213	TOUCH-UP PAINT, SHOP FOX WHITE

⚠ WARNING

Safety labels warn about machine hazards and how to prevent serious personal injury. The owner of this machine **MUST** maintain the original location and readability of all labels on this machine. If any label is removed or becomes unreadable, **REPLACE** that label before allowing machine to be operated again. Contact us at (360) 734-3482 or www.woodstockint.com to order new labels.



Warranty Registration

Name _____
 Street _____
 City _____ State _____ Zip _____
 Phone # _____ Email _____ Invoice # _____
 Model # _____ Serial # _____ Dealer Name _____ Purchase Date _____

The following information is given on a voluntary basis. It will be used for marketing purposes to help us develop better products and services. Of course, all information is strictly confidential.

- How did you learn about us?
 Advertisement Friend Local Store
 Mail Order Catalog Website Other:
- How long have you been a woodworker/metalworker?
 0-2 Years 2-8 Years 8-20 Years 20+ Years
- How many of your machines or tools are Shop Fox?
 0-2 3-5 6-9 10+
- Do you think your machine represents a good value? Yes No
- Would you recommend Shop Fox products to a friend? Yes No
- What is your age group?
 20-29 30-39 40-49
 50-59 60-69 70+
- What is your annual household income?
 \$20,000-\$29,000 \$30,000-\$39,000 \$40,000-\$49,000
 \$50,000-\$59,000 \$60,000-\$69,000 \$70,000+
- Which of the following magazines do you subscribe to?
 Cabinet Maker Popular Mechanics Today's Homeowner
 Family Handyman Popular Science Wood
 Hand Loader Popular Woodworking Wooden Boat
 Handy Practical Homeowner Woodshop News
 Home Shop Machinist Precision Shooter Woodsmith
 Journal of Light Cont. Projects in Metal Woodwork
 Live Steam RC Modeler Woodworker West
 Model Airplane News Rifle Woodworker's Journal
 Modeltec Shop Notes Other:
 Old House Journal Shotgun News

9. Comments: _____

CUT ALONG DOTTED LINE

FOLD ALONG DOTTED LINE

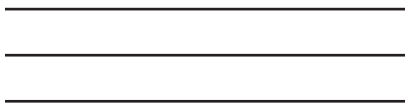

Place
Stamp
Here



WOODSTOCK INTERNATIONAL INC.
P.O. BOX 2309
BELLINGHAM, WA 98227-2309



FOLD ALONG DOTTED LINE

TAPE ALONG EDGES--PLEASE DO NOT STAPLE

WARRANTY

Woodstock International, Inc. warrants all Shop Fox machinery to be free of defects from workmanship and materials for a period of two years from the date of original purchase by the original owner. This warranty does not apply to defects due directly or indirectly to misuse, abuse, negligence or accidents, lack of maintenance, or reimbursement of third party expenses incurred.

Woodstock International, Inc. will repair, replace, or arrange for a dealer refund, at its expense and option, the Shop Fox machine or machine part proven to be defective for its designed and intended use, provided that the original owner returns the product prepaid to an authorized warranty or repair facility as designated by our Bellingham, Washington office with proof of their purchase of the product within two years, and provides Woodstock International, Inc. reasonable opportunity to verify the alleged defect through inspection. If it is determined there is no defect, or that the defect resulted from causes not within the scope of Woodstock International Inc.'s warranty, then the original owner must bear the cost of storing and returning the product.

This is Woodstock International, Inc.'s sole written warranty and any and all warranties that may be implied by law, including any merchantability or fitness, for any particular purpose, are hereby limited to the duration of this written warranty. We do not warrant that Shop Fox machinery complies with the provisions of any law, acts or electrical codes. We do not reimburse for third party repairs. In no event shall Woodstock International, Inc.'s liability under this limited warranty exceed the purchase price paid for the product, and any legal actions brought against Woodstock International, Inc. shall be tried in the State of Washington, County of Whatcom. We shall in no event be liable for death, injuries to persons or property or for incidental, contingent, special or consequential damages arising from the use of our products.

Every effort has been made to ensure that all Shop Fox machinery meets high quality and durability standards. We are committed to continuously improving the quality of our products, and reserve the right to change specifications at any time.

To register the warranty, go to <https://www.woodstockint.com/warranty>, or scan the QR code below. You will be directed to the Warranty Registration page on www.woodstockint.com. Enter all applicable production information.





High Quality Machines and Tools

Woodstock International, Inc. carries thousands of products designed to meet the needs of today's woodworkers and metalworkers.

Ask your dealer about these fine products:

BROSMAN
PRECISION STOP BLOCK

JOINTER PAL[®]

Rotacator[®]

STEELEX[®]
FINE TOOLS

PLANER PAL[®]

THE REBEL[®]

PRO-STIK[®]
ABRASIVE BELT & DISC CLEANER

BOARD BUDDIES[®]

WOODSTOCK
SHOP FOX[®]
INTERNATIONAL

STEELEX[®]
PLUS

SLICKPLANE[®]

Aluma-Classic[®]

ACCU-SHARP[®]

ROMAN
CARBIDE[®]

PARROT VISE[®]

WHOLESALE ONLY

WOODSTOCK INTERNATIONAL, INC.

Phone: (360) 734-3482 • Fax: (360) 671-3053 • Toll Free Fax: (800) 647-8801

P.O.Box 2309 • Bellingham, WA 98227

SHOPFOX.BIZ