

Recommended Maximum Weight

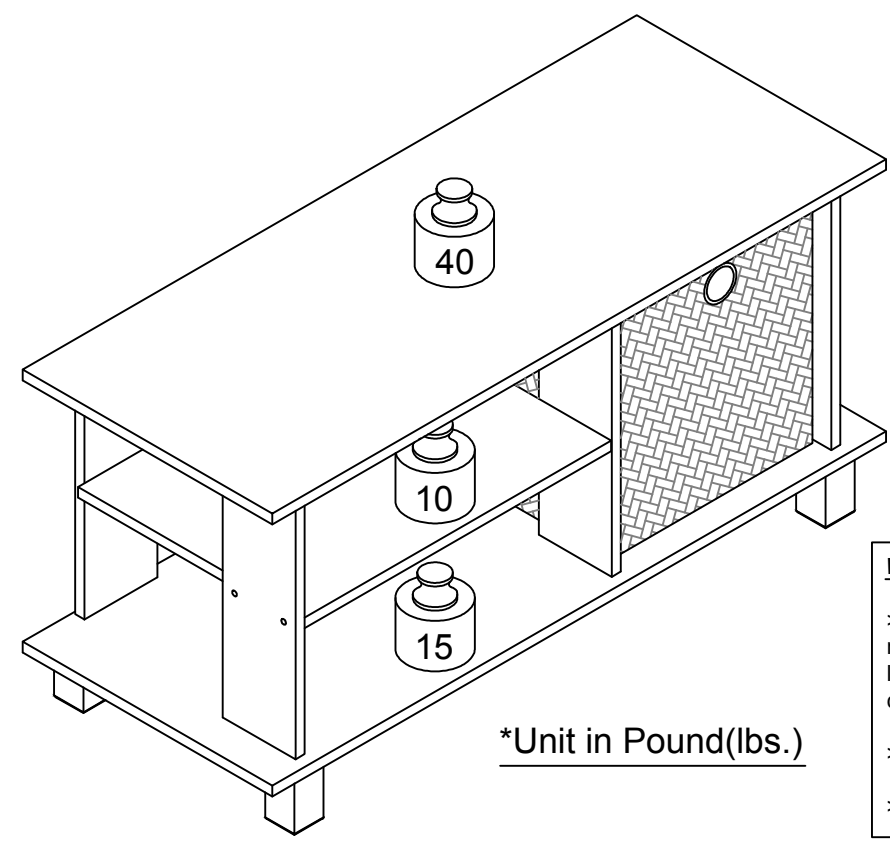

*Unit in Pound(lbs.)

WARNING:

- >This unit has been designed to support the maximum loads shown. Exceeding these load limits could cause sagging, instability, product collapse, and/or serious injury.
- >DO NOT allow children to climb on unit.
- > Put heavier items on lower shelves.



Assembly Instruction

Furinno Simplistic Entertainment Center
with Bin Drawers
MODEL : 13239

00:30

Approx. 30 minutes

Recomm. 1 Person

Tool Required

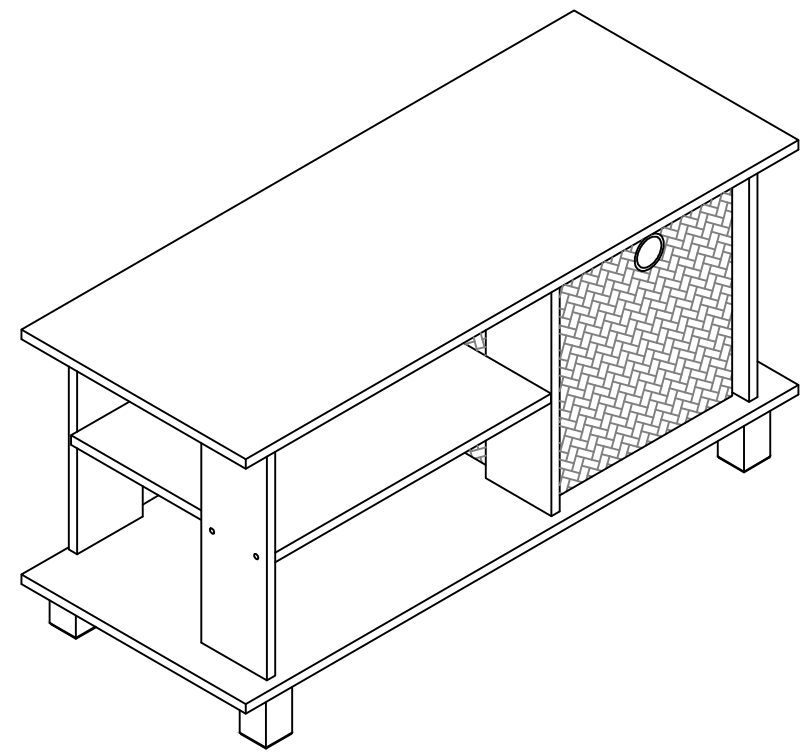

Customer Support

NEED HELP? For replacement requests or product inquiries, please contact our Customer Service Team by emailing us at support@furinno.com. Thank you for selecting Furinno!

www.furinno.com



EXPLODED VIEW

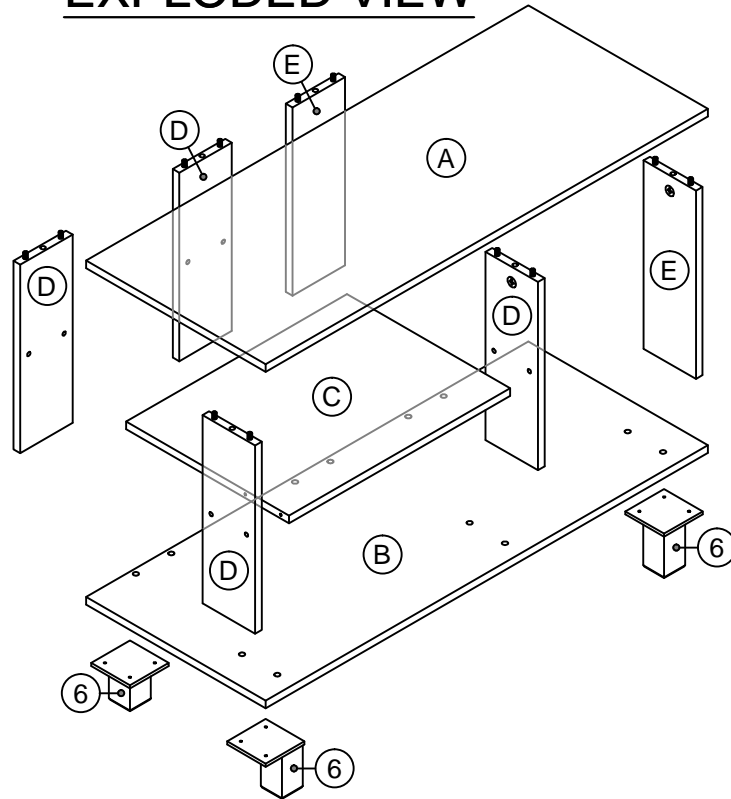

PARTS LIST

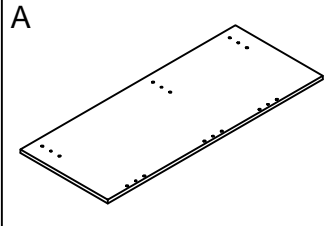
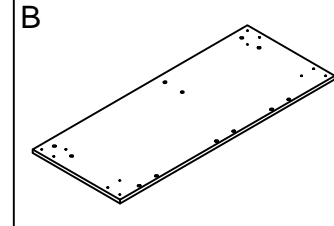
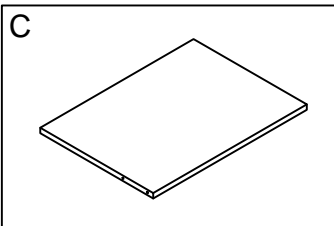
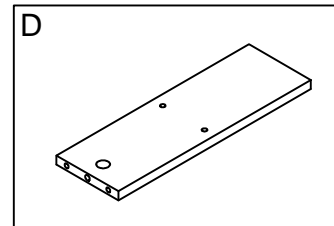
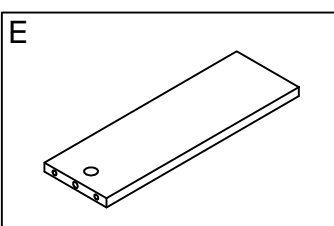
 TOP PANEL 1 PC	 BOTTOM PANEL 1 PC
 SHELF PANEL 1 PC	 LEFT SUPPORT PANEL 4 PCS
 RIGHT SUPPORT PANEL 2 PCS	

HARDWARE LIST

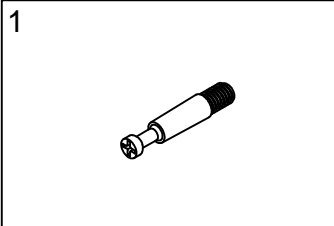
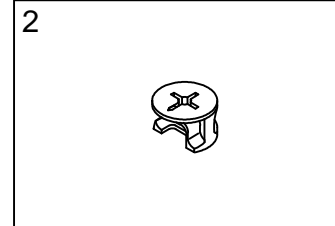
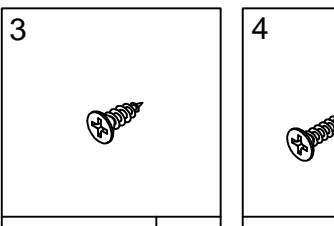
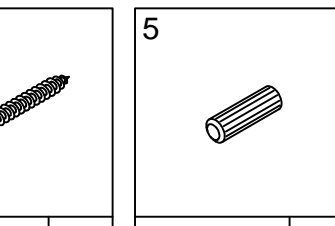
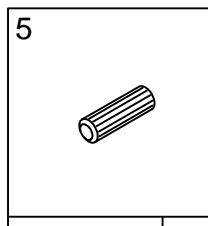
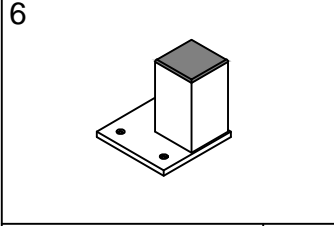
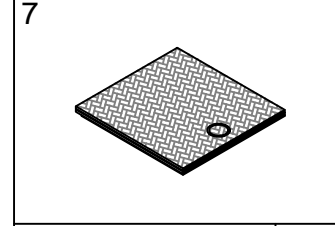
 CAM-LOCK SCREW 6 PCS	 CAM-LOCK NUT 6 PCS	
 SMALL SCREW 12 PCS	 LARGE SCREW 20 PCS	 DOWEL 12 PCS
 SQUARE LEG 4 PCS	 BIN 1 PC	

USEFUL HINTS BEFORE YOU START:

1. Read each step carefully before starting.
2. It is important that each step is performed in correct order to avoid difficulties.
3. Identify, soft and count the parts before assembly.
4. Assemble your furniture on packaging cardboard to prevent scratch or damage.
5. Clean the product with mild cleanser using soft damped cloth. Do not use harsh or abrasive cleanser.
6. Using incompatible hardware might cause damage to product.

STEP 9

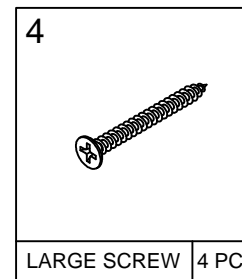
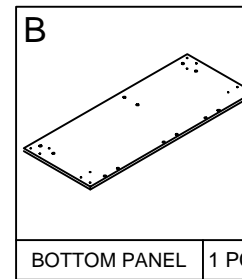
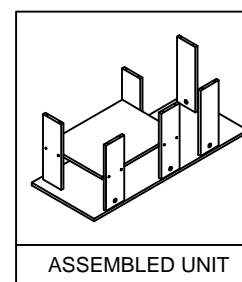

UNFINISHED SURFACE

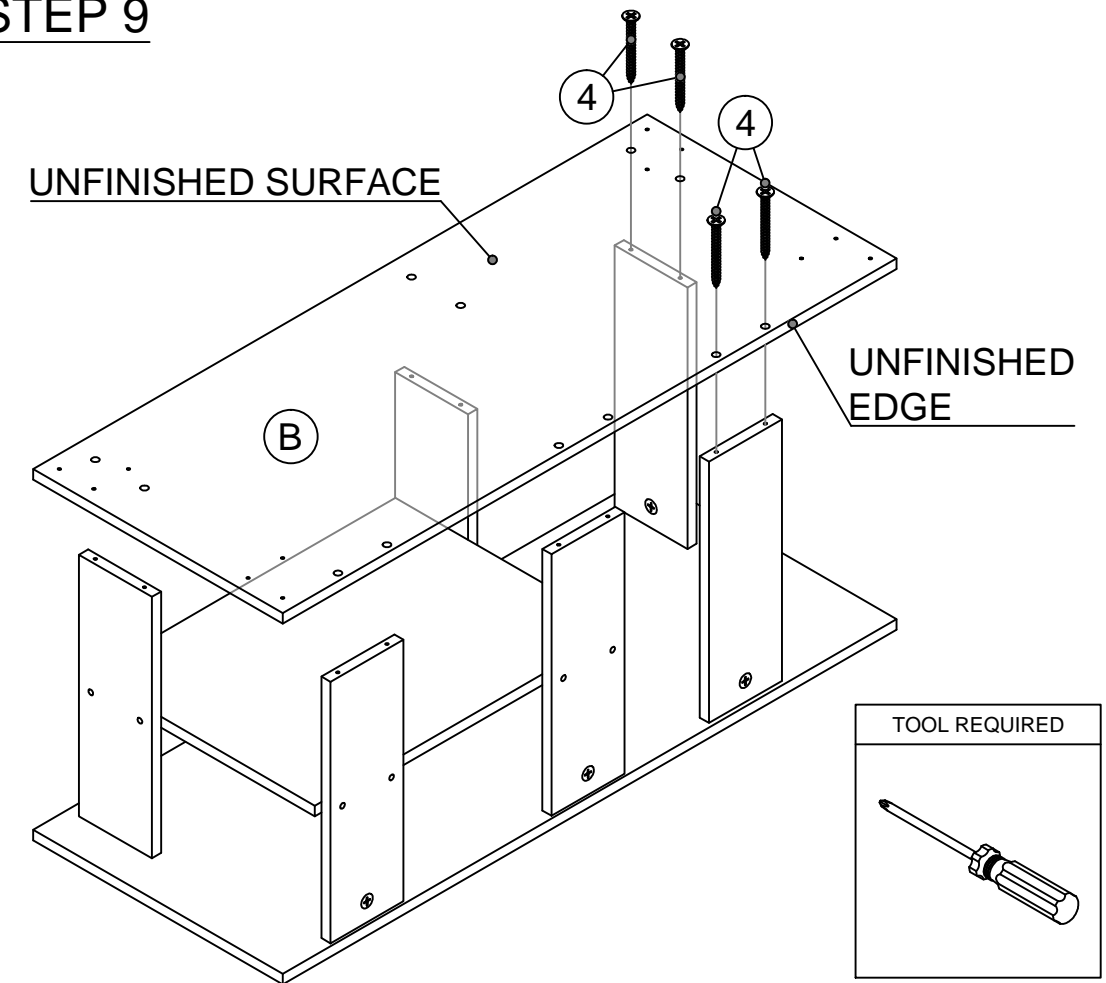

STEP 10

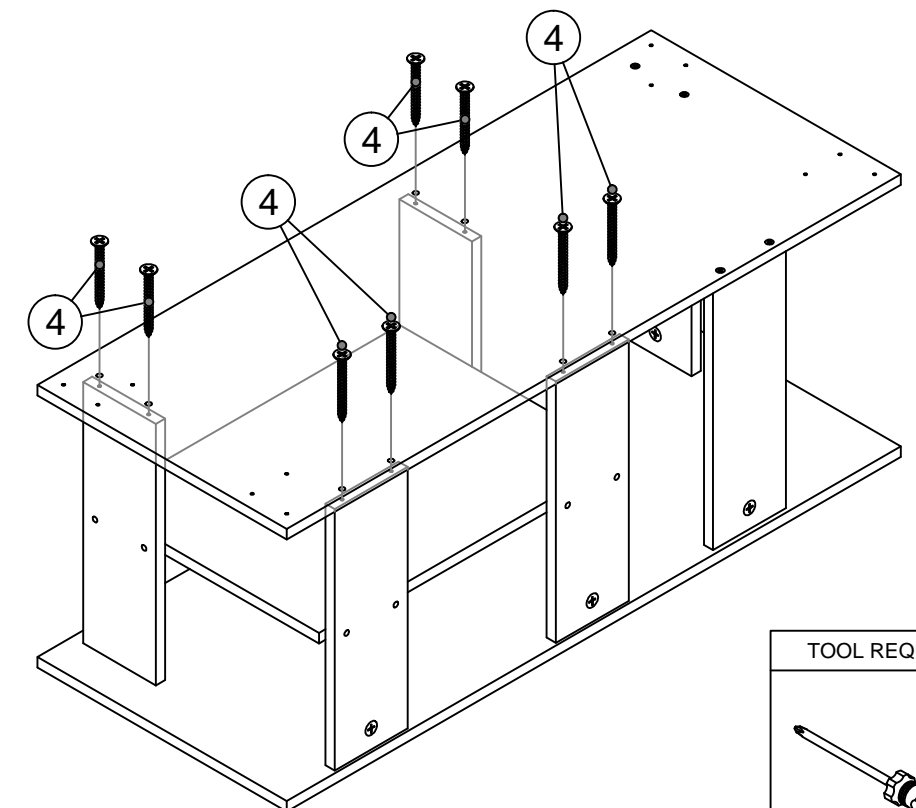
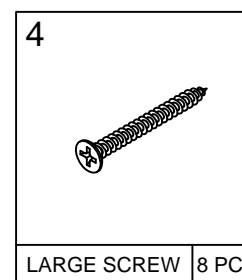
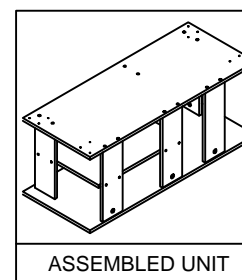

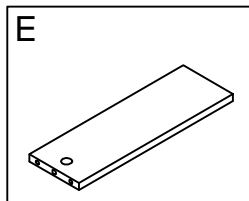

RIGHT SUPPORT PANEL | 2 PCS

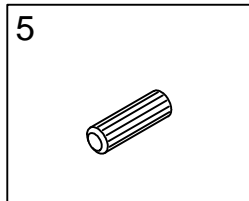

DOWEL | 4 PCS

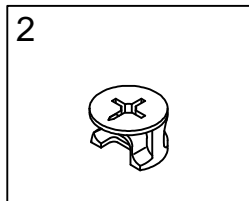

CAM-LOCK NUT | 2 PCS

STEP 7

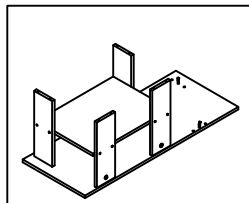
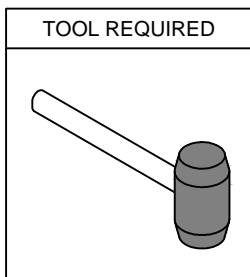
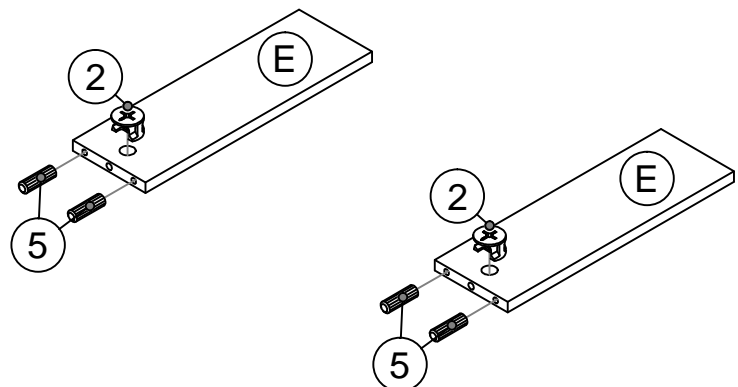

ASSEMBLED UNIT

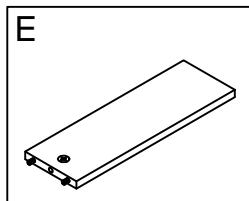

RIGHT SUPPORT PANEL | 2 PCS

STEP 8

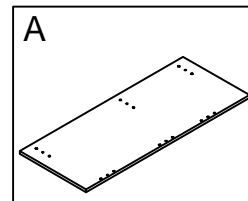
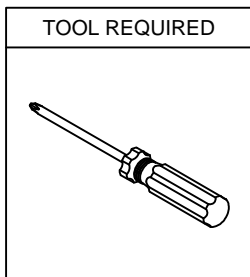
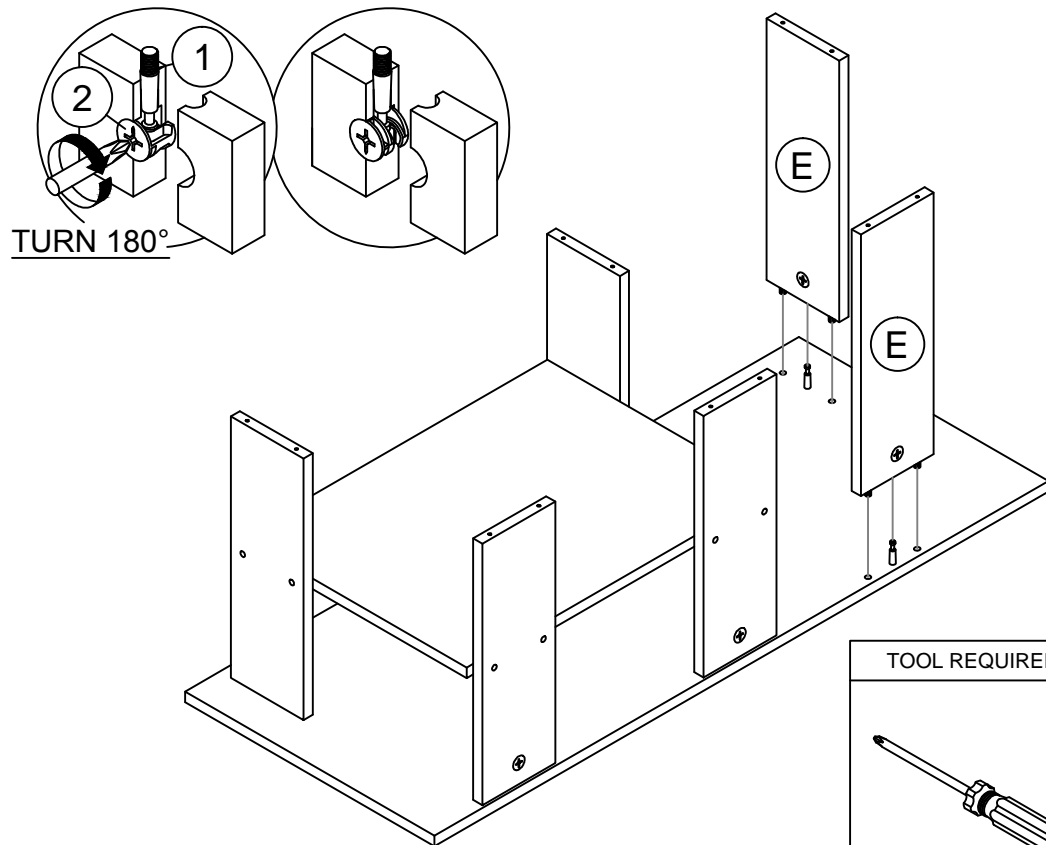

TOP PANEL | 1 PC

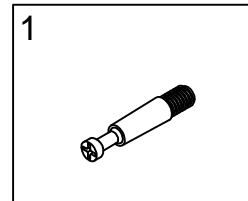

CAM-LOCK SCREW | 6 PCS

STEP 1

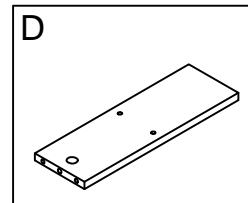
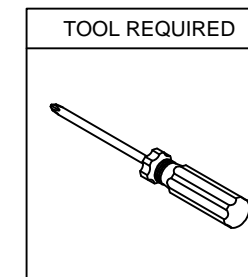
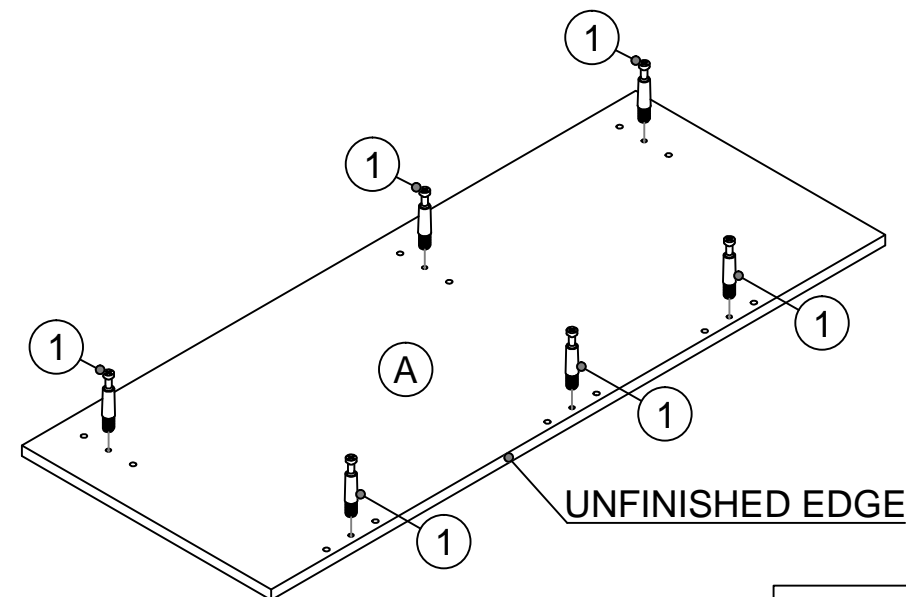

LEFT SUPPORT PANEL | 4 PCS

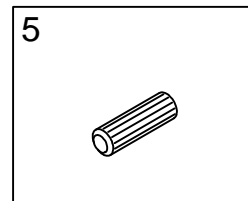

DOWEL | 8 PCS

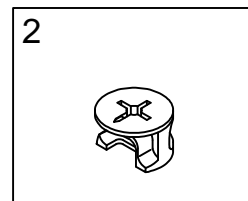

CAM-LOCK NUT | 4 PCS

STEP 2

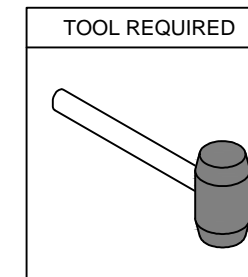
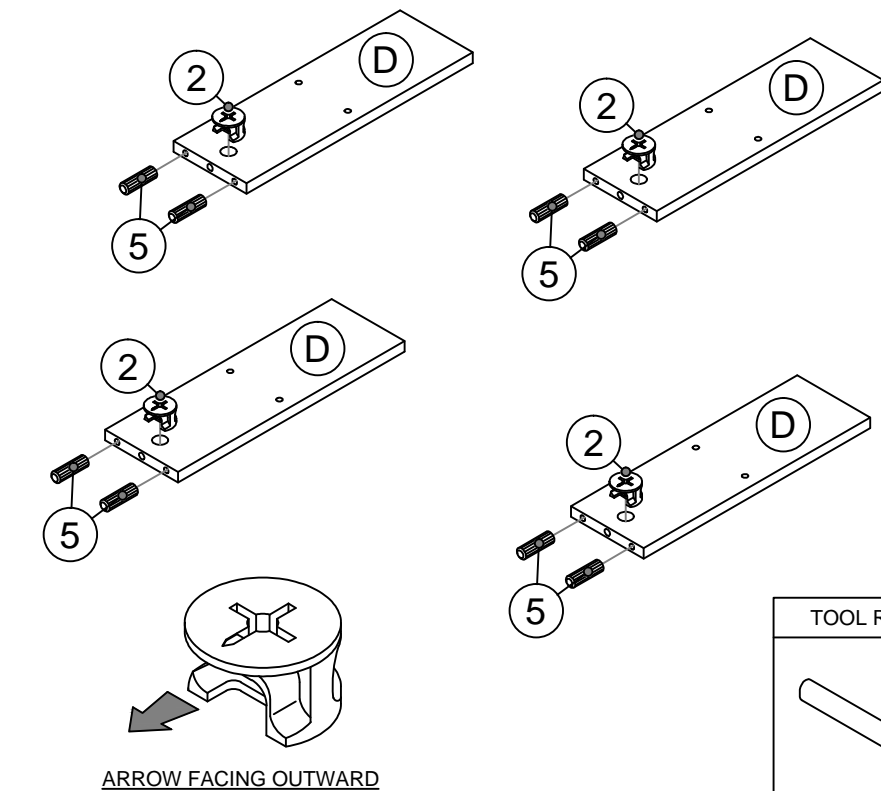

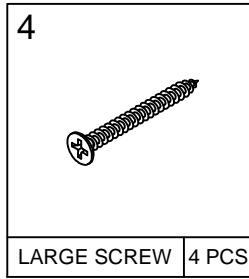
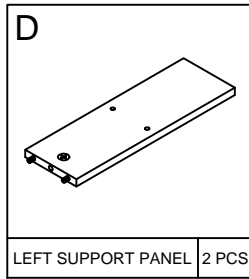
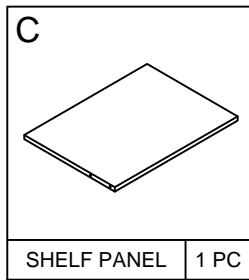

STEP 3

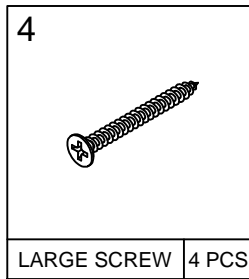
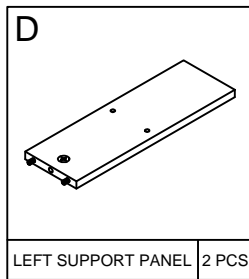
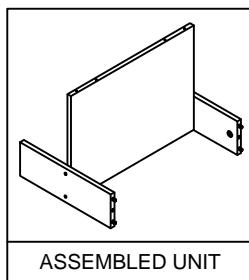
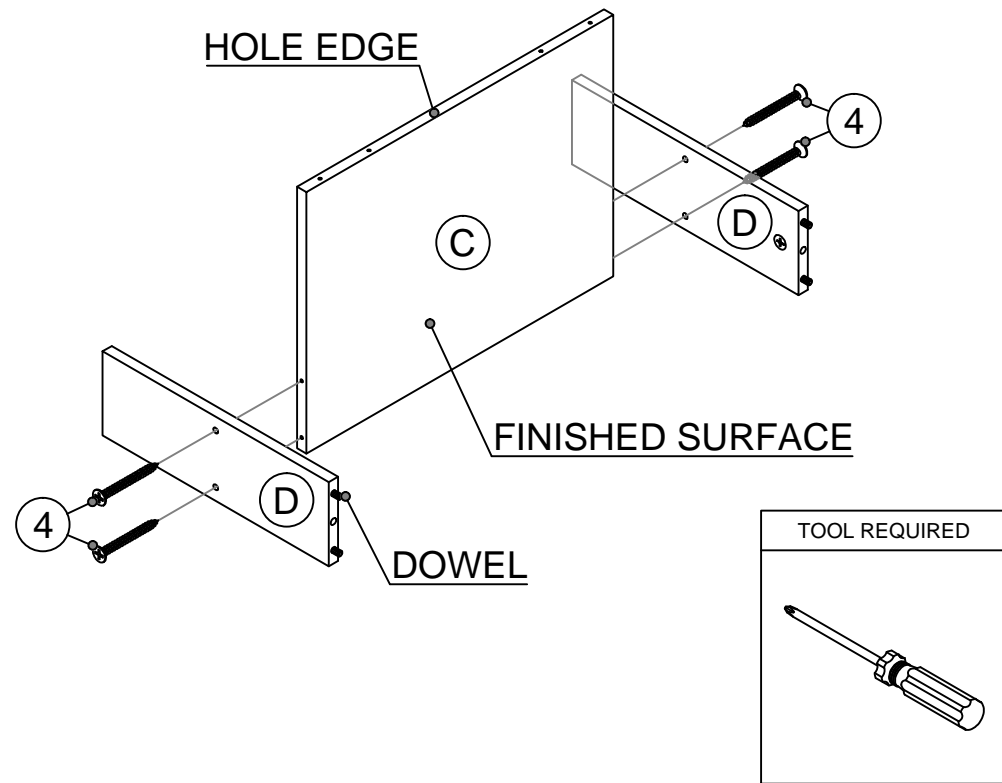

STEP 4

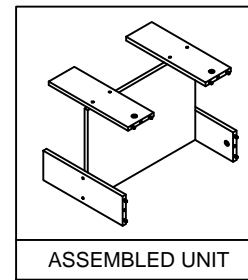
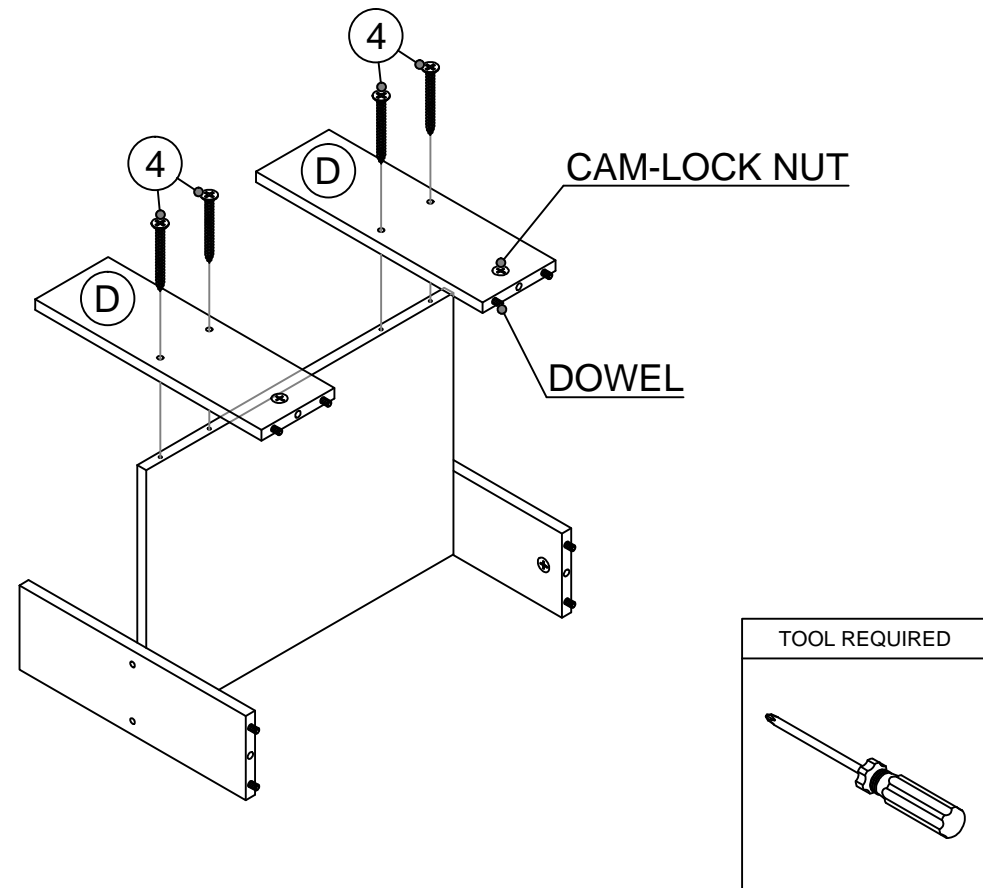

STEP 5

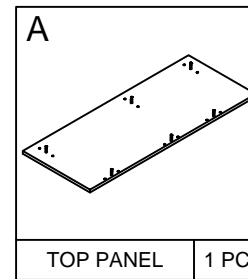
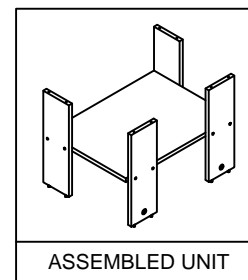
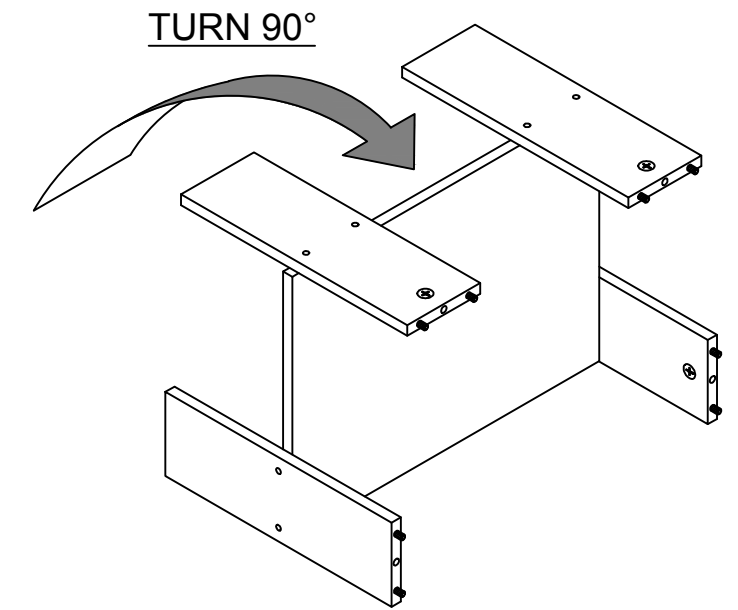

STEP 6

