



SKU# 1002 877 771  
THD.com# 1002 812 663  
Model #HOTC5623BB2S

## USE AND CARE GUIDE

### 56 IN. 23-DRAWER HEAVY DUTY TOOL CHEST AND CABINET SET- TEXTURED BLACK MATTE FINISH

Questions, problems, missing parts?  
Before returning to the store, call  
Husky Customer Service  
8 a.m - 7 p.m., EST, Monday-Friday,  
9 a.m. - 6 p.m., EST, Saturday

1-888-HD-HUSKY

HUSKYTOOLS.COM

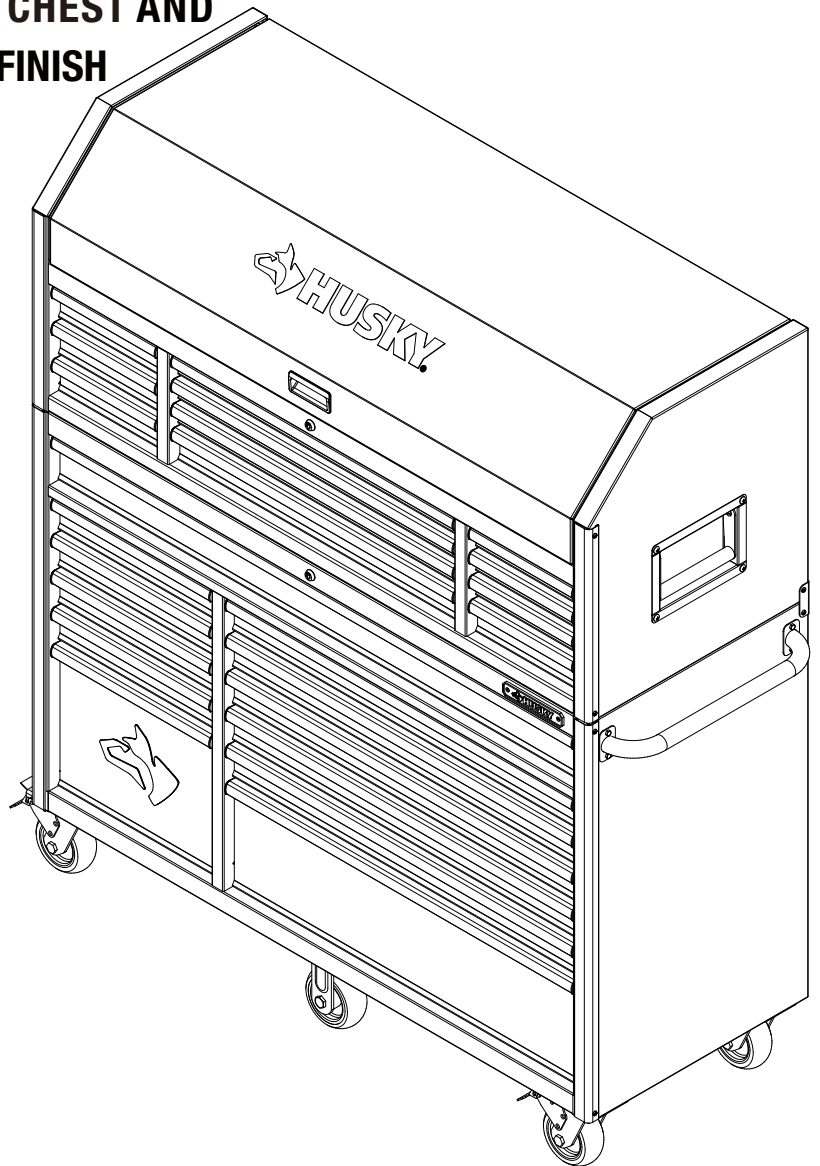

#### **THANK YOU**

*We appreciate the trust and confidence you have placed in Husky through the purchase of this chest/cabinet. We strive to continually create quality products designed to enhance your home. Visit us online to see our full line of products available for your home improvement needs. Thank you for choosing Husky!*

# Table of Contents

Table of Contents.....	2	Assembly.....	6
Safety Information.....	2-3	Operation.....	8
Warranty.....	3	Maintenance.....	9
Pre-Assembly.....	4	Care and Cleaning.....	9
Tools Required.....	4	Service Parts.....	10
Hardware Included.....	4		
Specifications.....	4		
Package Contents.....	5		

## Safety Information

1. Do not open more than one drawer at a time.
2. Do not let children approach the tool chest / cabinet, power strip and LED working light.
3. To help prevent the product from tipping, load the product starting with the bottom drawers.
4. Keep the locking casters brake set unless you are moving the cabinet. This will help to prevent the product from rolling.
5. Lock both the lid and all drawers before moving the cabinet / chest.
6. Do not step in any drawer / drawers.
7. When moving this product, push it rather than pull it.
8. Do not alter this product including power strip and LED working light in any manner.

### Plug and Outlet Safety



**WARNING:** This product is for use on a nominal 120-volt circuit and has a grounding plug. Chest/cabinet plugs must match the outlet. Never modify the plug in any way. Do not use any adapter plugs with earth (grounded) chest/cabinet power strips. Unmodified plugs and matching outlets will reduce risk of electric shock.



**WARNING:** Avoid body contact with earthed or grounded surfaces such as pipes, radiators, ranges and refrigerators. There is increased risk of electric shock if your body is earthed or grounded.



**WARNING:** Chests/cabinets marked "Grounding Required" have a power strip with a three wire cord and three prong grounding plug. The plug must be connected to a properly grounded outlet (See Figure). If the power strip should electrically malfunction or break down, grounding provides a low resistance path to carry electricity away from the user, reducing the risk of electric shock. The grounding prong in the plug is connected through the green wire inside the cord to the grounding system in the power strip. The green wire in the cord must be the only wire connected to the power strip's grounding system and must ever be attached to an electrically "live" terminal. Your power strip must be plugged into an appropriate outlet, properly installed and grounded in accordance with all codes and ordinances.

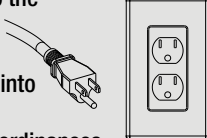

**DANGER:** Do not stand on this product. You may fall or cause the product to tip.



**DANGER:** Do not move the product prior to closing and locking all the drawers. The drawers could come open and make the product unstable and tip.



**DANGER:** Do not mount this product on a truck bed or any other moving object.



**WARNING:** Keep the product on a level surface. The product may become unstable and tip if stored or moved on an uneven surface.



**WARNING:** Be careful when closing the cover. Remove hands before closing the cover.



**WARNING:** Do not unplug by pulling on cord. To unplug, grasp the plug, not the cord.



**CAUTION:** Do not lift this product directly with a forklift or tow with any mechanical devices.



**CAUTION:** Do not exceed the maximum product weight, including contents. Do not exceed the maximum weight for each drawer. See Specifications on page 4.



**CAUTION:** Only transport this product when empty. Properly secure when transporting.



**WARNING:** Unplug from outlet when not in use, and before putting on or taking off parts.



**WARNING:** Keep the cord away from heated surfaces.

# Safety Information (continued)



**WARNING:** Do not use outdoors.



**WARNING:** The chest-cabinet is intended for household use.



**WARNING:** For loading always put heavier items at the bottom and not near the top in order to help prevent the possibility of the chest-cabinet tipping over.



**DANGER:** To reduce the risk of electric shock, always unplug this chest-cabinet from the electrical outlet before cleaning.

## LED Working Light Safety



**WARNING:** This product contains Li-ion battery. Use only the supplied USB charging cable and connect only to a suitable power outlet (DC 5V/2A).



**CAUTION:** This working light is designed for indoor use only. Do not use it in humid environments (like in a bathroom or outdoors). Otherwise the components inside may short-circuit and result in accidents.



**WARNING:** Do not allow the product to fall from high places.

This device complies with Part 15 of the FCC Rules. Operation is subject to the following two conditions: (1) This device may not cause harmful interference, and (2) This device must accept any interference received, including interference that may cause undesired operation.



**NOTE:** This equipment has been tested and found to comply with the limits for a Class B digital device, pursuant to Part 15 of the FCC Rules. These limits are designed to provide reasonable protection against harmful interference in a residential installation. This equipment generates, uses and can radiate radio frequency energy and, if not installed and used in accordance with the instructions, may cause harmful interference to radio communications. However, there is no guarantee that interference will not occur in a particular installation. If this equipment does cause harmful interference to radio or television reception, which can be determined by turning the equipment off and on, the user is encouraged to try to correct the interference by one or more of the following measures:

- Reorient or relocate the receiving antenna.
- Increase the separation between the equipment and receiver.
- Connect the equipment into an outlet on a circuit different from that to which the receiver is connected.
- Consult the dealer or an experienced radio/TV technician for help.



**WARNING:** Changes or modifications to this unit not expressly approved by the party responsible for compliance could void the user's authority to operate the equipment.

The Responsible party information:  
Clearwater Metal Vn JSC  
Lot CN2, Mai Trung IZ, An Tay Village, Ben Cat Town, Binh Duong Province, Vietnam. Tel: +84.274.3581.773

Product name: Power strip 8 outlets with 2 USB ports  
Model# K2415010

# Warranty

The manufacturer warrants the product to be free from defects in materials and workmanship for a period of five (5) years from date of purchase. This warranty applies only to the original consumer and only to products used in normal use and service. If this product is found to be defective, the manufacturer's only obligation, and your exclusive remedy, is the repair or replacement of the product at the manufacturer's discretion, provided that the product has not been damaged through misuse, abuse, accident, modifications, alteration neglect or mishandling. This warranty shall not apply to any product that is found to have been improperly installed, set-up, or used in any way not in accordance with the instructions supplied with the product. This warranty shall not apply to a failure of the product as a result of an accident, misuse, abuse, negligence, alteration, faulty installation, or any other failure not relating to faulty material or workmanship. This warranty shall not apply to the finish on any portion of the products such as surface and/or weathering, as this is considered normal wear and tear.

The manufacturer does not warrant and specifically disclaims any warranty, whether express or implied, of fitness for a particular purpose, other than the warranty contained herein. The manufacturer specifically disclaims any liability and shall not be liable for any consequential or incidental loss or damage, including but not limited to any labor/expense costs involved in the replacement or repair of said product.

Contact the Customer Service Team at 1-888-HD-HUSKY or visit [www.huskytools.com](http://www.huskytools.com).

# Pre-assembly

## TOOLS REQUIRED

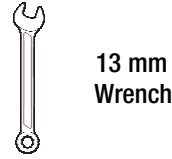
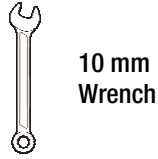
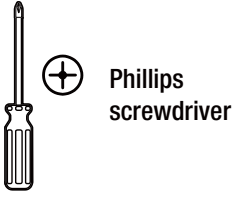

## HARDWARE INCLUDED



**NOTE:** Hardware not shown to actual size.

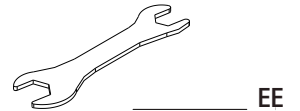
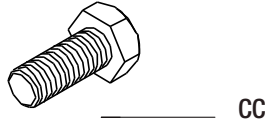
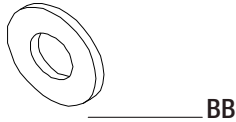
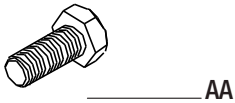

Part	Description	Quantity
AA	Bolt M6x15L	4
BB	Washer M8	24
CC	Bolt M8x15L	24
DD	Screw M4x10L	8
EE	10 mm/13 mm wrench	1

## SPECIFICATIONS

Maximum capacity (chest drawer)	1200 lbs.
Maximum capacity (cabinet drawer)	1800 lbs.
Empty weight	623.9 lbs.



**NOTE:** Begin product assembly close to the final intended location of your chest/cabinet. This product is heavy and may be difficult to move after assembly.

# Pre-assembly (continued)

## PACKAGE CONTENTS

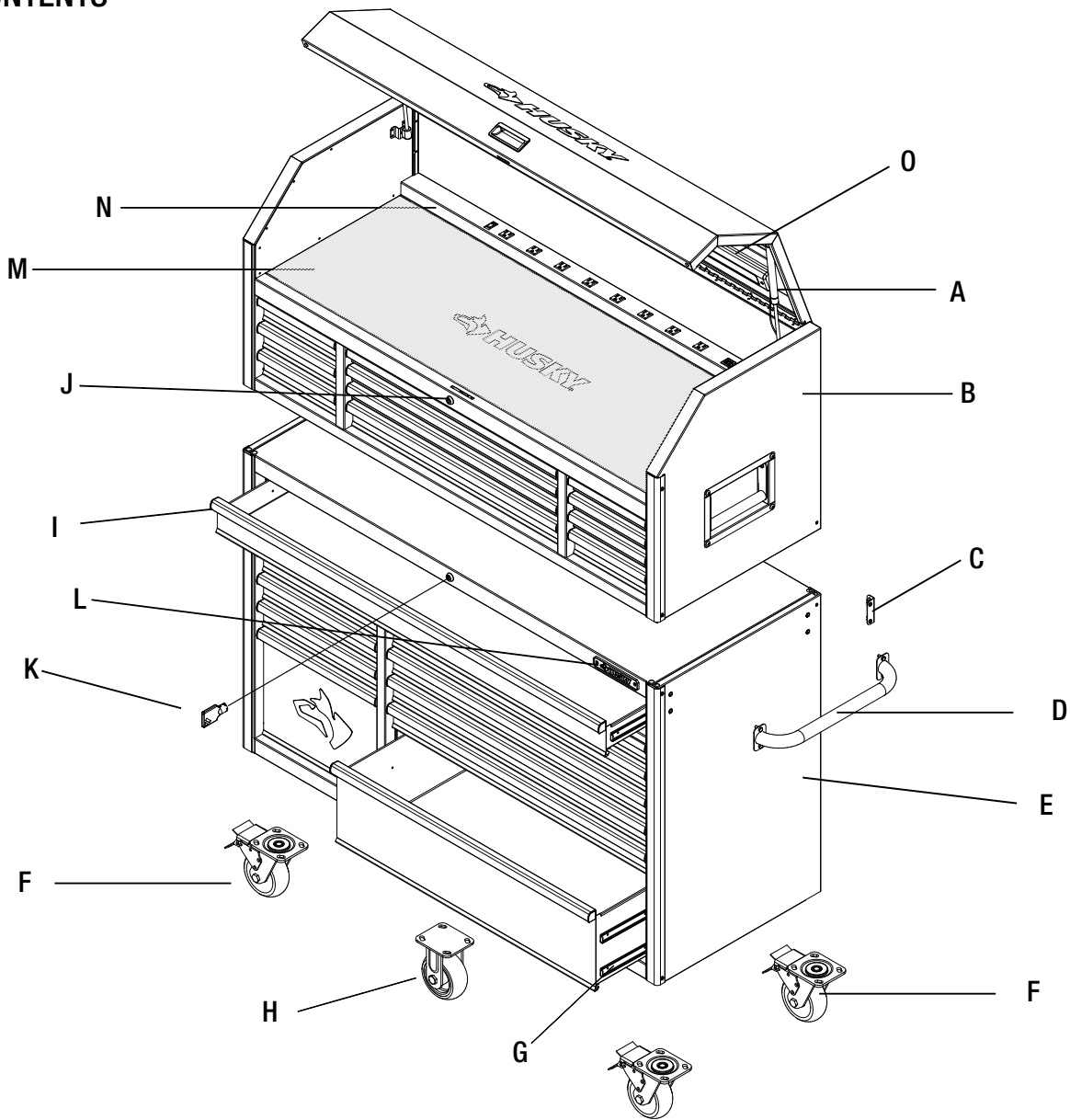

Part	Description	Quantity
A	Gas lift	2
B	Top chest	1
C	Bracket	2
D	Side handle	1
E	Rolling cabinet	1
F	Swivel caster with brake	4
G	Drawer slide (pair)	25

Part	Description	Quantity
H	Regular caster	2
I	Drawer	18
J	Lock	2
K	Key (set)	2
L	Husky badge	2
M	Drawer Liner	24
N	8-outlet power strip	1
O	Portable LED work light	1

# Assembly

## 1 Attaching the side handle

- Attach the side handle (D) to the rolling cabinet (E) using four bolts (AA).



**NOTE:** The holes in the cabinet are tapped and do not require nuts.

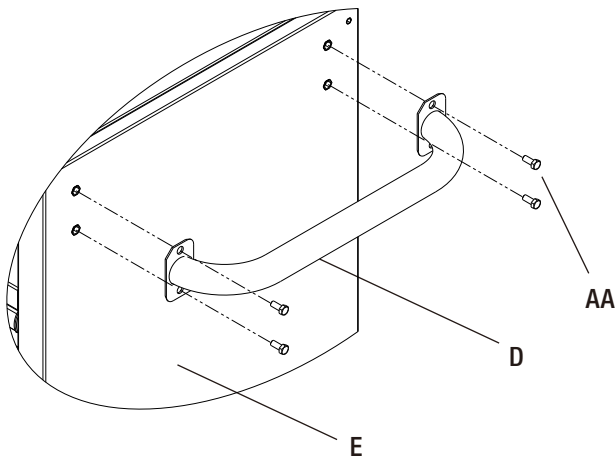

## 2 Installing the casters



**CAUTION:** Do not over tighten the screws.

- Ensure all cabinet drawers are securely locked into place using the key lock on the rolling cabinet (E).
- Lay the rolling cabinet (E) on its back. Use the packaging material to protect the finish.
- Mount the four swivel casters with brake (F) to the rolling cabinet (E) using four bolts (CC) and washers (BB) per caster. The swivel casters with brake (F) should be installed on each end at the cabinet.
- Mount the two regular casters (H) to the center of the rolling cabinet (E) using four bolts (CC) and washers (BB) per caster.
- Tighten all bolts with a wrench.
- Return the rolling cabinet (E) to its upright position.

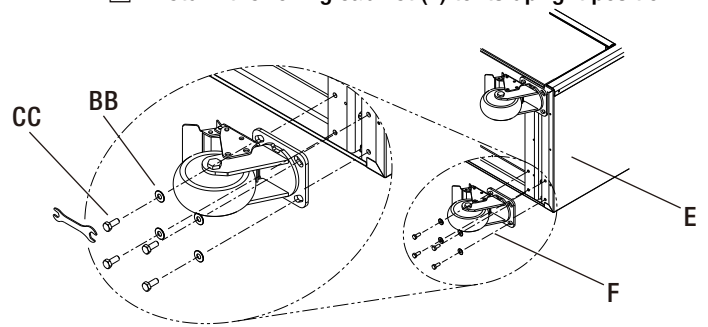

## 3 Placing the chest



**NOTE:** Two people may be required to complete this step.

- Place the top chest (B) on top of the rolling cabinet (E).

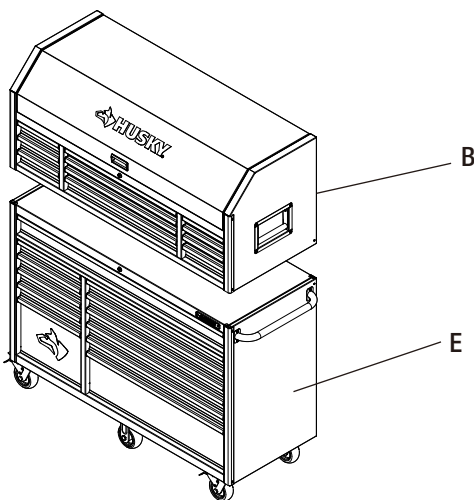

## 4 Installing the brackets



**NOTE:** The holes in the cabinet are tapped and do not require nuts.

- Attach the brackets (C) to the back of the product to secure the top chest (B) to the rolling cabinet (E). Place the brackets over the holes and secure with four screws (DD) per bracket.
- Tighten all screws securely with a screwdriver.

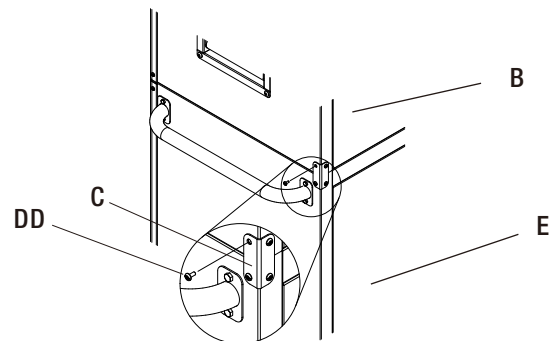

### 5 Installing the drawer liner

- Place the drawer liners (M) in appropriately sized drawers and the chest lid area to protect the surface.

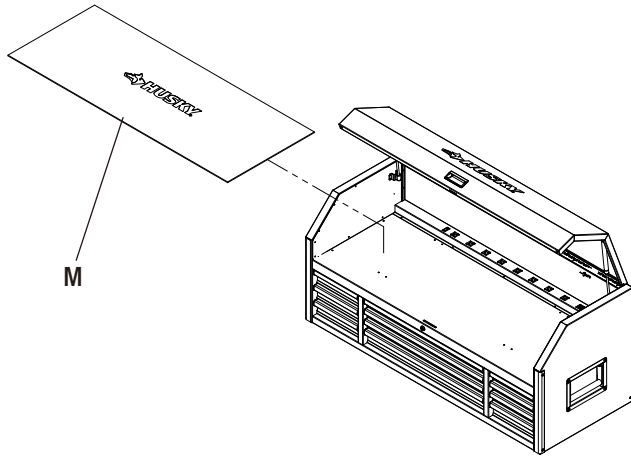



# Operation

## 1 Locking and unlocking the unit



**IMPORTANT:** The drawers must be fully closed before locking / unlocking the unit.

- Insert the key (K) and turn it fully to the left to lock.
- Remove the key (K).
- Insert the key (K) and turn it fully to the right to unlock.
- Remove the key (K).

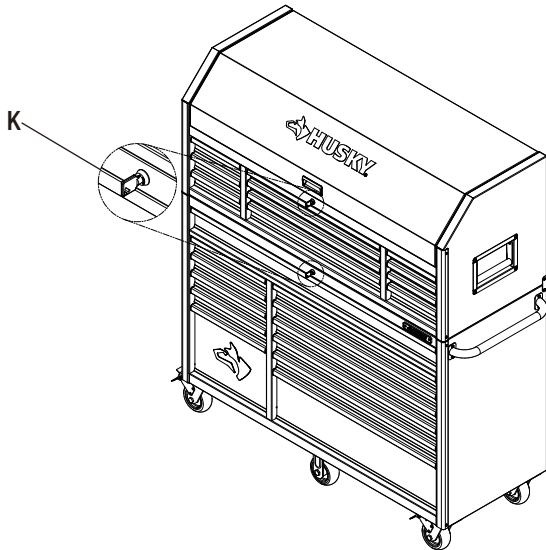

## 2 Removing the drawers

- Fully extend and empty the drawer.
- Depending on the slide, either lift or lower the release lever on both sides so the slides can ride over the stops. Pull out to remove.

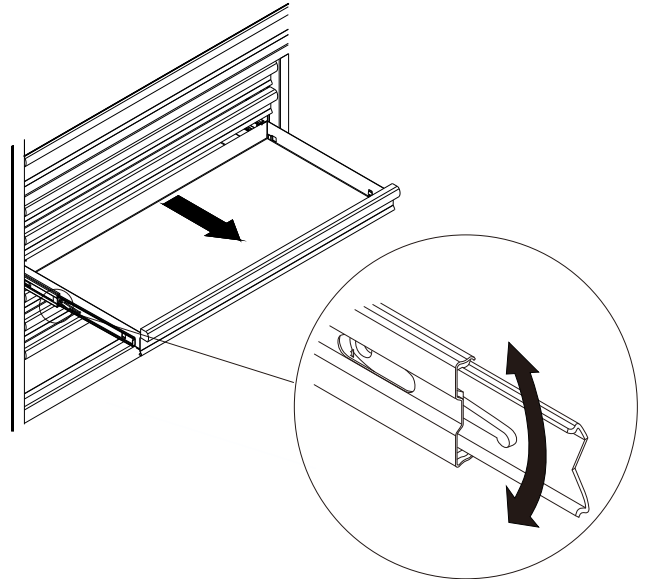

## 3 Installing the drawers

- Pull the slides and slide carrier out until fully extended.
- Hold the slide on the cabinet while aligning it with the slide on the drawer.
- Slightly insert one side and repeat for the other side.
- Slowly push the drawer until it is fully closed to engage the slide.
- Open the drawer and close it to verify proper operation.

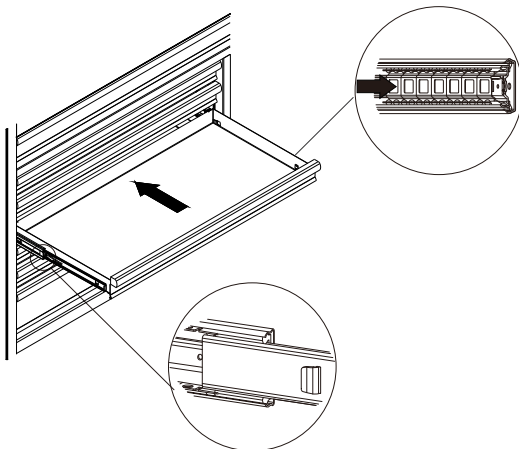

## 4 Installing the LED work light

- Place the magnetic LED work light (O) on tool chest for extra light. Recharge by plugging it into a power source which can provide DC 5V/2A current.
- Press the button on the LED light to turn the light on full illumination. Press it for second time to adjust to half illumination. Press a third time to turn the light off.
- When the light is not plugged in, there is an additional flash (S.O.S.) light mode.
- During a power failure, the light automatically turns on to half illumination for 30 minutes and then automatically shuts off. You can also press the button to switch between lighting modes.

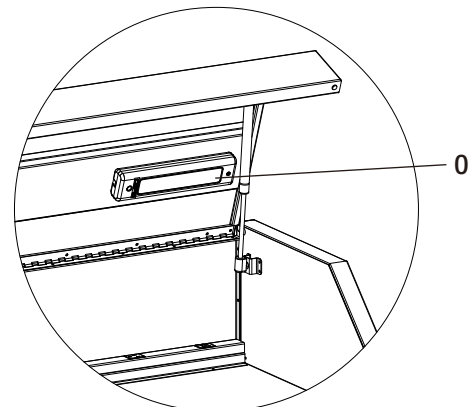



# Maintenance

## 1 Maintaining the casters

- Grease the casters annually using high quality bearing grease.

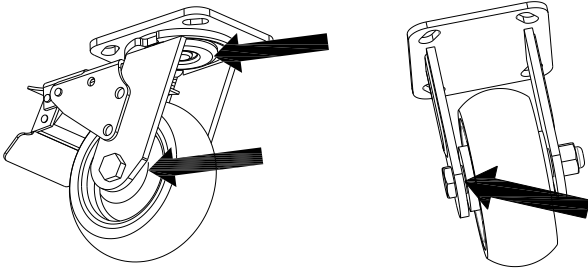

## 2 Maintaining the drawers

- Periodically clean the drawer trim, and inside the drawers with a mild detergent and water.
- Remove grease and oil with a standard, nonflammable cleaning fluid.
- The use of drawer liners is recommended to protect the finish inside the drawers and make the drawers easier to clean. Drawer liners can be purchased at The Home Depot and can be cleaned with soap and water.
- Lubricate the slides semi-annually with grease or equivalent.

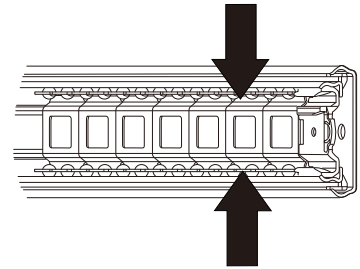

# Care and Cleaning

- This steel product has been coated with industrial powder coating for a durable finish.
- To help protect the powder coated finish, do not allow harsh chemicals (oil, grease, or other chemical) to remain on the powder coating surface.
- Use a glass cleaner (Windex® or equivalent product) to clean and maintain all surfaces of powder coating.

# Service Parts

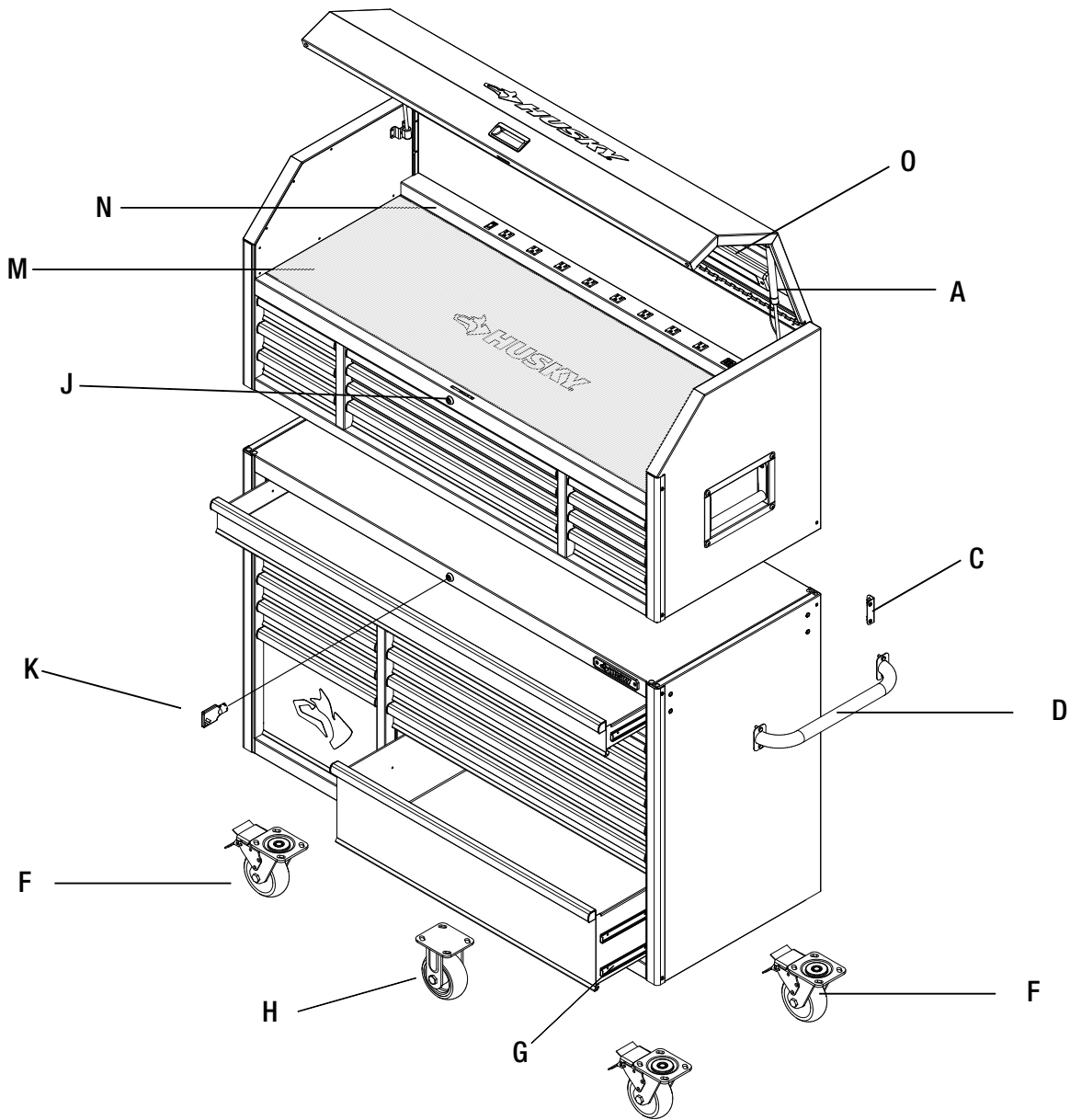

Part	Description	Quantity
A	Gas lift	2
C	Bracket	2
D	Side handle	1
F	Swivel caster with brake	4
G	Drawer slide (pair)	25
H	Regular caster	2
J	Lock	2
K	Key (set)	2
M	Drawer Liner	24
N	8-outlet power strip	1
O	Portable LED working light	1



Questions, problems, missing parts? Before returning to the store, call  
Husky Customer Service  
8 a.m. - 7 p.m., EST, Monday-Friday, 9 a.m. – 6 p.m., EST, Saturday

**1-888-HD-HUSKY**

**HUSKYTOOLS.COM**

Retain this manual for future use.