



# **COOKTOP USER MANUAL & INSTALLATION INSTRUCTIONS**

## **IMPORTANT SAFETY INSTRUCTIONS**

Carefully read the following Important information regarding installation safety and maintenance.

Keep these instruction for future reference.

# Safety Information & Installation Instruction

## BEFORE YOU BEGIN

Read these instructions completely and carefully.

- IMPORTANT — Save these instructions for local inspector's use.
- IMPORTANT — Observe all governing codes and ordinances
- Note to Installer – Be sure to leave these instructions with the Consumer
- Note to Consumer – Keep these instructions for future reference.
- IMPORTANT — Check the leakage according to the installation instruction.
- Product failure due to improper installation is not covered under the Warranty

## FOR YOUR SAFETY:

 **WARNING** — If the information in this manual is not followed exactly, a fire, explosion or gas leak may result, causing property damage, personal injury or death.

 Do not store or use gasoline or other flammable vapors and liquids in the vicinity of this or any other appliance.

 **WHAT TO DO IF YOU SMELL GAS:**

- Do not try to light any appliance. Do not touch any electrical switch; do not use any phone in your building.
- Immediately call your gas supplier from a neighbor's phone. Follow the gas supplier's instructions.
- If you cannot reach your gas supplier, call the fire department.

Installation and service must be performed by a qualified installer, service agency or the gas supplier.

 **WARNING** — Disconnect all electrical power at the main circuit breaker or fuse box before installing.

Installation of this cooktop must conform with local codes or, in the absence of local codes, with the National Fuel Gas Code, ANSI Z223.1/NFPA54– Latest Edition ANSI Z223.1/NFPA

- Be sure your cooktop is installed properly by a qualified installer or service technician.
- To eliminate reaching over surface burners, cabinet storage above burner should be avoided
- Do not install the unit near an outside door or where a draft may affect its use.

1. A statement that the installation must conform with local codes or, in the absence of local codes, with the *National Fuel Gas Code, ANSI Z233.1/NFPA 54*.

2. A statement that the installation of appliances designed for manufactured (mobile) home installation must conform with the *Manufactured Home Construction and Safety Standard, Title 24 CFR, Part 3280* [formerly the Federal Standard for Mobile Home Construction and Safety, Title 24, HUD (Part 280)] or with local codes where applicable.

3. If an external electrical source is utilized, a statement that the appliance, when installed, must be electrically grounded in accordance with local codes or, in the absence of local codes, with the *National Electrical Code. ANSI/NFPA 70.*

4. A statement that:

(a) The appliance and its individual shutoff valve must be disconnected from the gas supply piping system during any pressure testing of that system at test pressures in excess of 1/2 psi (3.5kpa).

(b) The appliance must be isolated from the gas supply piping system by closing its individual manual shutoff valve during any pressure testing of the gas supply piping system at test pressures equal to or less than 1/2 psi (3.5kPa).

5. A statement of the maximum gas supply pressure in accordance with the inlet pressure rating of the gas appliance pressure regulator supplied.

6. A description of proper vent installation, if applicable, and the specific type of gas vent to be used, including a statement that the vent pipe must be mechanically fastened to the flue collar and instructions for accomplishing this attachment.

#### **IN THE COMMONWEALTH OF MASSACHUSETTS:**

- This product must be installed by a licensed plumber or gas fitter.
- When using ball-type gas shut-off valves, they shall be the T-handle type.
- A flexible gas connector, when used, must not exceed 3 feet.

Be sure the installation of this product in a mobile home conforms with the Manufactured Home Construction and Safety Standard, Title 24 CFR, Part 3280. If this standard does not apply, you must follow the standard for Manufactured Home Installations, ANSI A225.1 and Manufactured Home Installations, Sites and Communities, ANSI/NFPA 501A or with local codes. You can get a copy of the Federal Standard by Writing: Office of Mobile Home Standards HUD Building 451 7th Street, S.W. Washington, D.C. 24010.

#### **ELECTRICAL REQUIREMENTS**

This appliance must be supplied with the proper voltage and frequency and connected to an individual, properly grounded branch circuit, protected by a circuit breaker or fuse having amperage as noted on the rating plate.

We recommend you have the electrical wiring and hookup of your cooktop connected by a qualified electrician. After installation, have the electrician show you where your main cooktop disconnect is located.

Check with your local utilities for electrical codes which apply in your area. Failure to wire your cooktop according to governing codes could result in a hazardous condition. If there are no codes, your cooktop must be wired and fused to meet the requirements of the National Electrical Code, ANSI/NFPA No. 70—Latest Edition. You can get a copy by writing: National Fire Protection Association Batterymarch Park Quincy, MA 02269

In Canada, your cooktop must be wired and fused to meet the requirements of the Canadian Electrical Code.

## TABLE OF CONTENTS

SAFETY INFORMATION .....	1
FOR YOUR SAFETY .....	1
INSTALLATION PREPARATION.....	4
INSTALLATION OPTIONS .....	6
DIMENSIONS AND CLEARANCES .....	6
POWER SUPPLY LOCATIONS .....	7
INSTALLATION INSTRUCTIONS .....	10
ASSEMBLE BURNERS, CHECK IGNITION .....	11
CONVERT NATURAL GAS TO LP GAS OPERATION .....	15
CONVERT LP GAS TO NATURAL GAS OPERATION .....	19
SOLUTIONS TO COMMON PROBLEMS.....	24

## INSTALLATION PREPARATION

### PRE-INSTALLATION CHECKLIST

1. When preparing cooktop opening, make sure the inside of the cabinet and the cooktop do not interfere with each other. (See section on preparing the opening.)
2. Slide the cooktop out of the end of the box. Remove packaging materials, grate boxes, regulator and literature package from the cooktop before beginning installation.
  - Use the shipping carton as a pad to protect customer countertops or flooring
3. Remove Installation Instructions from literature package and read them carefully before you begin. Be sure to place all literature, Owner's Manual, Installations, etc. in a safe place for future reference.
4. Make sure you have all the tools and materials you need before starting the installation of the cooktop.
5. Your home must provide the adequate electrical service needed to safely and properly you're your cooktop. (Refer to section on electrical requirements.)
6. When installing your cooktop in your home, make sure all local codes and ordinances are followed exactly as stated.
7. Make sure the wall coverings, countertop and cabinets around the cooktop can withstand heat (up to 200°F) generated by the cooktop.

### PARTS INCLUDED:



(2) Screws Regulator,



(2) Hold Down Brackets

### MATERIALS YOU MAY NEED:



Joint Sealant Pipe Fittings Shut-Off Valve,



CSA-Approved Flexible Gas Line

1/2" Min. ID, 1/2" NPT Connection, 3-foot Maximum Length (Massachusetts Only)

**Note:** Purchase new line, do not use previously used flexible gas line.

## TOOLS YOU WILL NEED FOR INSTALLATION

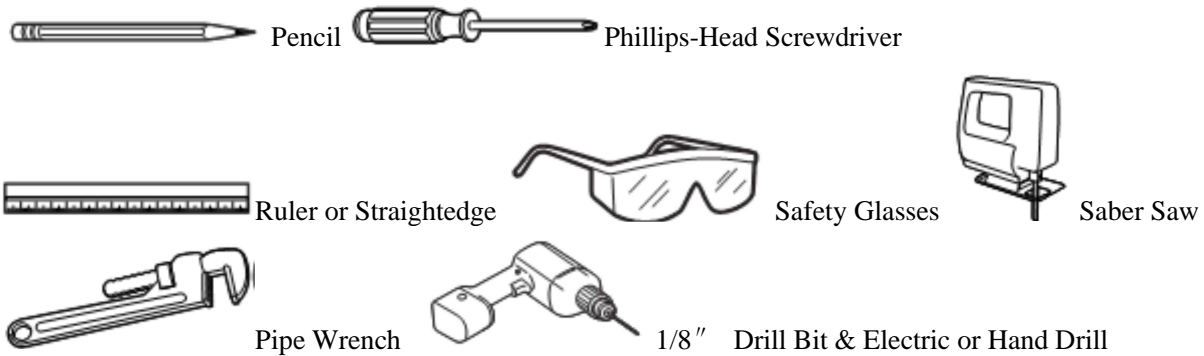

## ADVANCE PLANNING

- Refer to “Installation Preparation” for information on appropriate placement and necessary clearances when planning installation.
- Avoid placing cabinetry directly above cooktop when possible.
- If cabinetry is used above cooking surface:
  - Use cabinets no more than 13” deep.
  - Maintain 30” minimum clearance between cooktop and unprotected cabinets directly above cooktop.
  - If clearance is less than 30”, protect cabinet bottoms with flame-retardant millboard at least 1/4” thick, or gypsum board at least 3/16” thick, covered with 28 gauge sheet steel or .02” thick copper.
  - Clearance between cooktop and protected cabinetry must not be less than 24”.
  - An exhaust hood that projects at least 5” beyond front of cabinets can reduce risk of burns caused by reaching over heated surface units.
  - Working areas adjacent to the cooktop should have 18” minimum clearance between countertop and cabinet bottom.
- A 36” or wider exhaust hood with 350 CFM or greater airflow rating is recommended for use over this Monogram cooktop.
- Installation must conform with local codes. In the absence of local codes, the gas cooktop must comply with the National Fuel Gas Code, ANSI Z223.1, latest edition.
- Gas supply should be located near the opening for this cooktop (see Preparing the Opening and Gas Connection sections of this manual). The supply should provide natural gas at 7” of water column pressure (11” of water column for LP gas) and a maximum of 14” of water column for natural or LP gas.
- The electric spark ignition feature for this model requires a 120V electrical power supply be located in the immediate vicinity of this cooktop (see Electrical Connections section of this manual).

**WB28T10185 High Altitude Kit: For operation above 5,000 feet, order WB28T10185 Conversion Kit. This kit includes orifices for both LP and Natural Gas operation.**

## INSTALLATION OPTIONS

### Cooktop and Downdraft Vent Combination Installation

These cooktops may be installed with a 36" Downdraft Vent. See page 12 for cutout and clearances.

—The countertop must have a deep flat surface to accommodate the combined installation of the cooktop and vent.

—The downdraft vent with blower, motor and ductwork will occupy the base cabinet.

—Consideration must be given to electrical and gas supply locations. See page 8.

### Cooktop and Warming Drawer Combination Installation

These cooktops may be installed over a Monogram 30" or 27" Warming Drawer. See page 13 for cutout and clearances.

—Consideration must be given to electrical and gas supply locations. See page 8.

### Cooktop and Single Oven Combination Installation

These cooktops may be installed over a Monogram 30" Oven. See page 14 for cutout and clearances.

—Consideration must be given to electrical and gas supply locations. See page 8.

### Installation Above Cabinet Drawers

· When installing the cooktop above a base cabinet with drawers, it may be necessary to use a shorter depth (front to back) drawer to allow clearance for the gas connection.

## DIMENSIONS AND CLEARANCES

1. Overall cooktop dimensions:

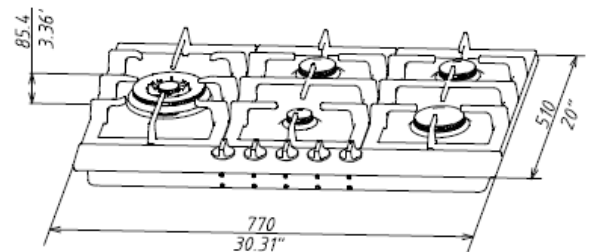
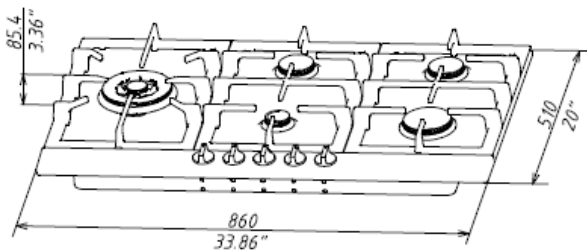

2. Use a 36" or wider base cabinet.

· Cut the opening in the countertop. To ensure accuracy, it is best to make a template for the opening.

Make sure the sides of the opening are parallel and the rear and front cuts are exactly perpendicular to the sides.

· Observe all minimum clearances.

COS850SLTX-E and COS950SLTX-E clearances:



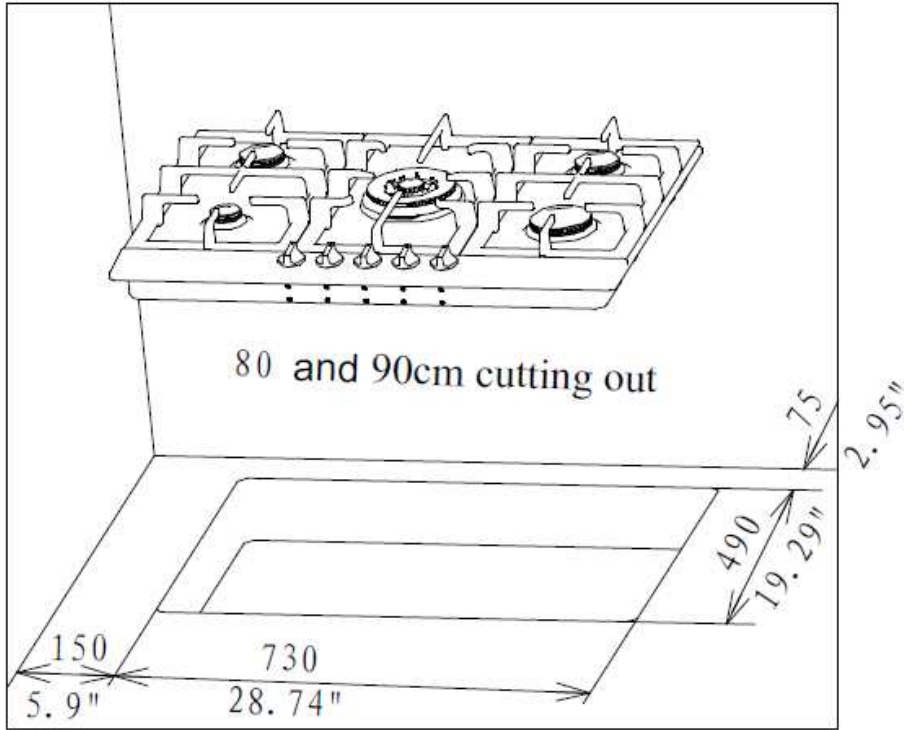

3. Make sure the wall coverings, countertop and cabinets around the cooktop can withstand heat (up to 200°F) generated by the cooktop.

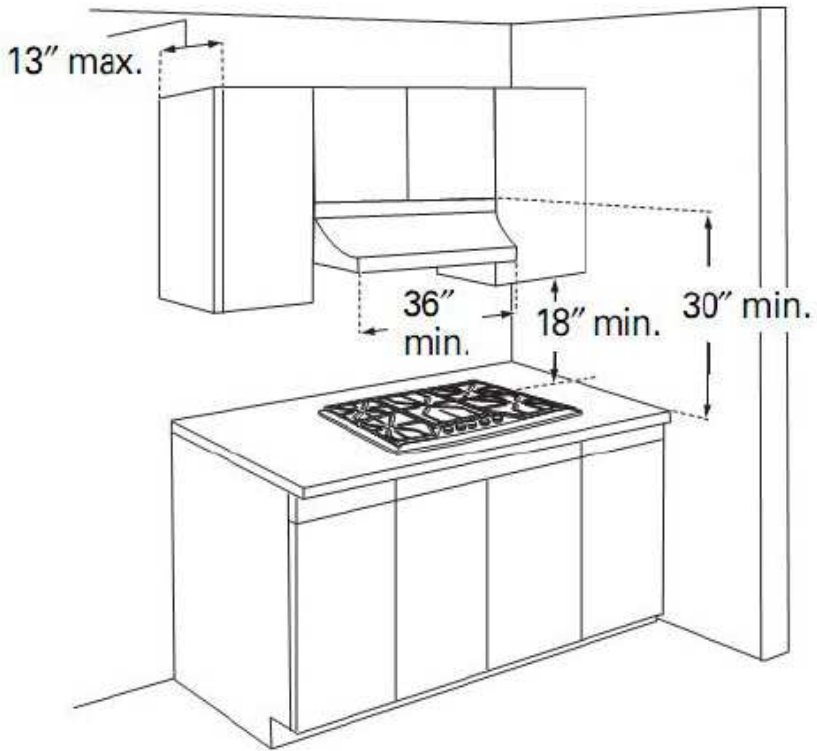



## POWER SUPPLY LOCATIONS

**Gas supply:** These cooktops are shipped from the factory set for either natural gas or LP gas. Check to be sure you have the correct cooktop for the type of gas being used.

- The pressure regulator must be connected in series with the manifold of the cooktop and must remain in series with the supply line regardless of type of gas being used.
- The natural gas model is designed to operate at 5" water column pressure. A regulator is required at the natural gas source to provide a minimum of 6" water column to the cooktop regulator
- The liquid propane model is designed to operate at 10" water column pressure. A regulator is required at the LP source to provide a minimum of 11" water column to the cooktop regulator.

For ease of installation, and if local codes permit, the gas supply line into the cooktop should be 1/2" or 3/4" ID flexible metal appliance connector, three to five feet long.

NOTE: Purchase new flexible line. DO NOT USE OLD, PREVIOUSLY USED FLEXIBLE LINE

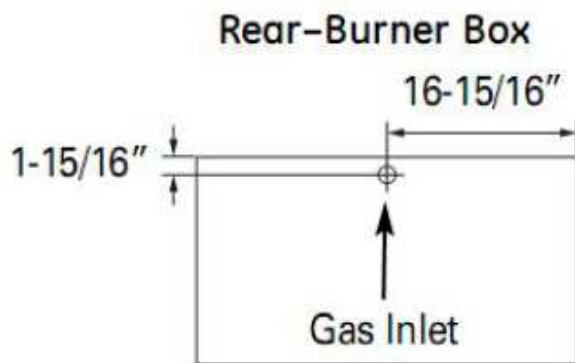

**The gas inlet is located on the bottom of the burner box at the rear and center.**

- Make gas connection through rear wall, or on cabinet floor at rear, as illustrated.
1. Install the house gas supply at least 1" from the back wall.

2. Locate the electrical outlet 12" below the countertop.

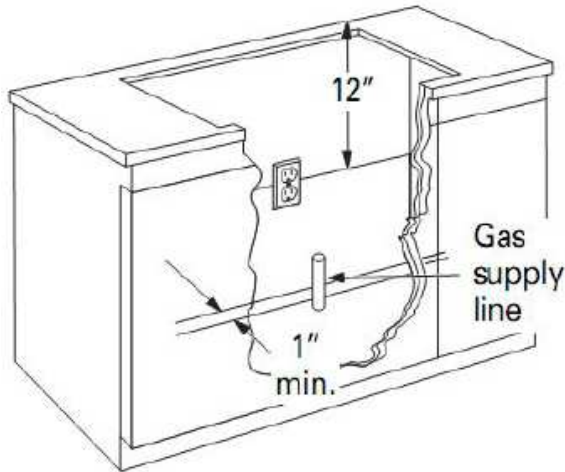

**Install a manual shut-off valve in the gas line in an easily accessible location outside the cooktop. Be sure you know how and where to shut off the gas supply to the cooktop. Install the electrical outlet 12" below the countertop.**

### **Electrical supply:**

This cooktop features pilotless electric ignition for energy savings and reliability. It operates on a 120 volt, 60 Hz power supply. A separate circuit, protected by a 15 amp time delay fuse or circuit breaker is required.

- A properly-grounded 3-prong receptacle should be located within reach of the cooktop's four-foot power cord.

**IMPORTANT: (Please read carefully). FOR PERSON SAFETY, THIS APPLIANCE MUST BE PROPERLY GROUNDED.**

- The power cord of this appliance is equipped with a three-prong (grounding) plug which mates with a standard three-prong grounding wall receptacle to minimize the possibility of electric shock hazard from this appliance.
- The customer should have the wall receptacle and circuit checked by a qualified electrician to make sure the receptacle is properly grounded and has correct polarity.
- Where a standard two-prong wall receptacle is encountered, it is the personal responsibility and obligation of the customer to have it replaced with a properly grounded three-prong wall receptacle.

**Do Not, Under Any Circumstances, Cut Or Remove The Third (Ground) Prong From The Power Cord. Do not use an extension cord.**

# Installation Instructions

## 1. INSTALLING THE COOKTOP

A. Remove the screws on the sides of the cooktop burner box. Use those screws to attach the side mounting brackets.

B. Insert the cooktop centered into the cutout opening. Make sure the front edge of the countertop is parallel to the cooktop. Check clearances at the front, back and sides.

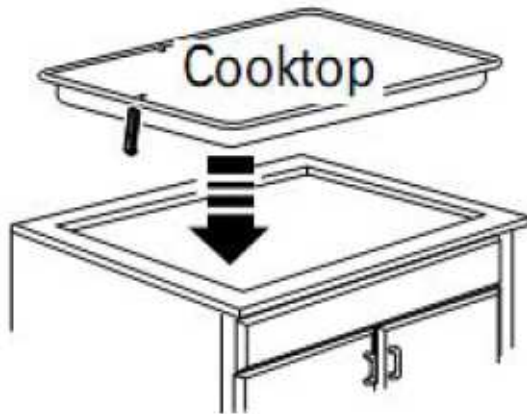

Secure the hold-down bracket to the cabinet sides with screws.

## 2. INSTALL PRESSURE REGULATOR

**⚠️ WARNING:** Never reuse old flexible connectors. The use of old flexible connectors can cause gas leak and personal injury. Always use new flexible connectors when installing a gas appliance. To reduce the possibility of gas leaks, apply Teflon tape or a thread compound approved for use with LP or Natural gas to all threaded connections.

A. Screw the regulator onto the burner box bottom pipe connection. Make sure the top of the regulator is facing toward the cabinet front and the arrow on the back of the regulator points to the cooktop.

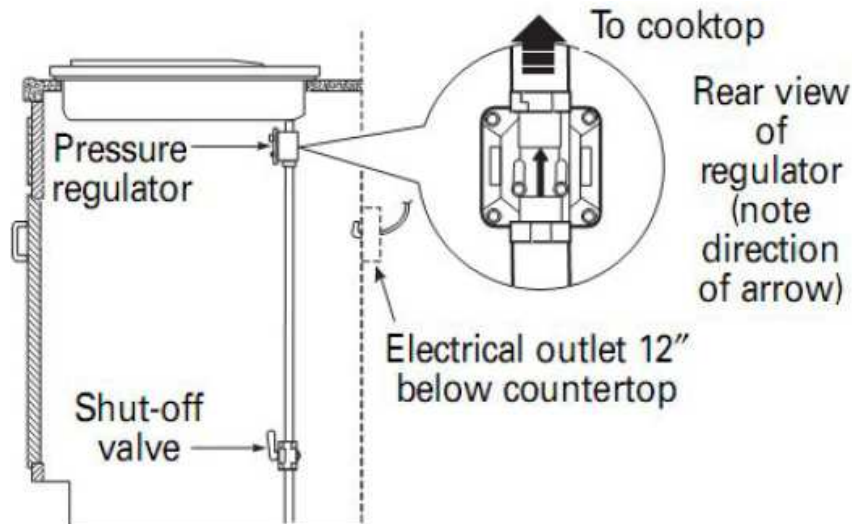

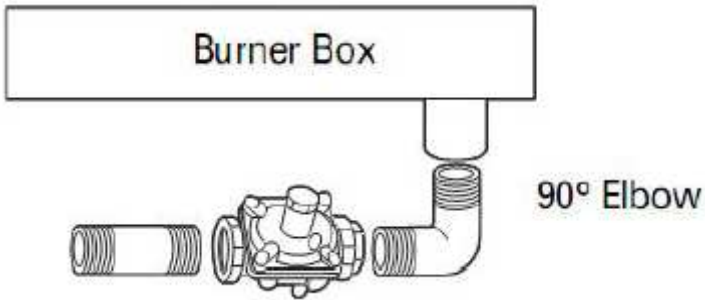

OPTION: You can install a 90° elbow (not supplied) onto the gas inlet and route the gas connections to avoid interference when installed over an oven, with a downdraft vent, a warming drawer or other cabinetry features.

B. Complete the connection between the regulator and the shut-off valve.

C. Before testing for leaks, make sure all burner knobs are in the OFF position.

After connecting the cooktop to gas, check system for leaks with a manometer. If a manometer is not available, turn the gas supply on to the cooktop and use a liquid leak detector at all joints and connections to check for leaks. Tighten all connections if necessary to prevent gas leakage in the cooktop or supply line.

**⚠ WARNING: Do not use a flame to check for leaks.**

Disconnect the cooktop and its individual shut-off valve from the gas supply piping system during any pressure testing of that system at test pressures greater than 1/2 psig (3.5 kPa).

Isolate the cooktop from the gas supply piping system by closing its individual shut-off valve during any pressure testing of the gas supply system at test pressures equal to or less than 1/2 psig (3.5 kPa).

### 3. CONNECT ELECTRICAL

- Check to be sure the receptacle is properly grounded.
- Plug in the power cord.

## ASSEMBLE BURNERS, CHECK IGNITION

The electrode of the electronic ignition system is positioned above the surface of the burner base. Do not remove a burner cap or touch the electrode of a burner while another is turned on. Damage or electrical shock may occur.

- a) The electrode of the electronic ignition system is positioned above the surface of the burner base. Do not remove a burner cap or touch the electrode of a burner while another is turned on. Damage or electrical shock may occur.
- b) Place burner heads over the burner base. Make sure the hole in the burner head is properly aligned with the electrode in the burner base.



c) Place the burner caps on the burner heads. Make sure that the burner caps are properly seated on the burner heads.



Burner cap properly seated Burner cap not properly seated

D. Check igniters.

Operation of the electric igniters should be tested after the cooktop and supply line have been carefully checked for leaks and the cooktop has been connected to the electrical power.

- Push and turn a burner valve to the LITE position. All spark igniters will make a series of sparks (ticking sounds), but only the burner turned to LITE will light.

—The burner should light when gas is available to the burner.

—Once the burner lights, it should be turned to another position.

- Test each valve separately until all burners have been checked.

**IMPORTANT:** If the igniter electrodes continue to spark after all of the burners are lit, check that each burner component is assembled and properly seated.

E. Burner ignition.

**Cooktop Spark Ignition**—When you turn the cooktop knob to LITE, the spark igniter makes a series of electric sparks (ticking sounds) which light the burner. During a power failure, the burners will not light automatically. In an emergency, a cooktop burner may be lit with a match by following the steps below.

 **WARNING:** Lighting gas burners with a match is dangerous. You should match light the cooktop burners only in an emergency.

- Light a match and hold the flame near the burner you want to light. Wooden matches work best.
- Push in and turn the control knob slowly. Be sure you are turning the correct knob for the burner you are lighting.

**NOTE:** If the burner does not light within five seconds, turn the knob off and wait one minute before trying again.

F. Turn on each burner. On LP models, flames should be blue in color but may have yellow tips. Natural gas models should have soft, blue flames. The burner flames should not flutter or blow away from the burner. The flame should be no less than 1/4" on the lowest setting and no greater than 1-1/2" on highest setting.

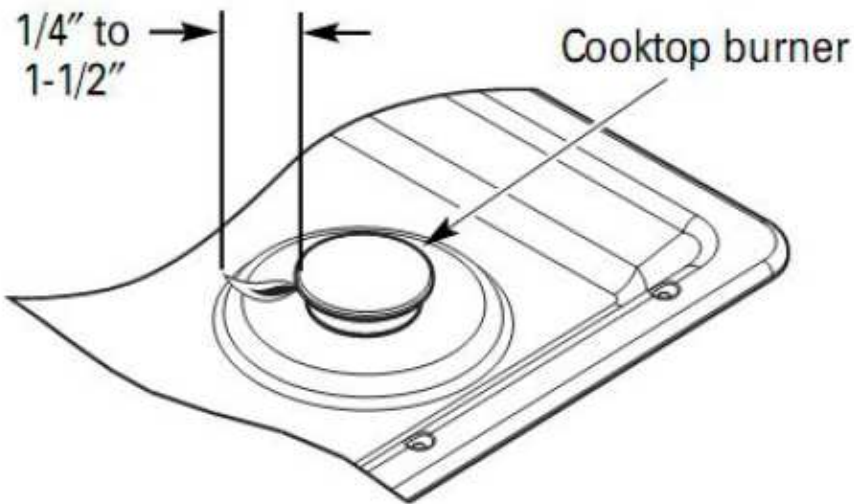

Burners should be checked frequently.

 **WARNING:** If you attempt to measure the flame, please use caution. Burns could result.

## OPERATION CHECKLIST

1. Make sure all controls are left in the OFF position.
2. The serial plate for your cooktop is located on the bottom of the burner box. In addition to the model and serial numbers, it tells you the ratings of the burners and the type of fuel and pressure the cooktop was adjusted for when it left the factory.
3. When ordering parts, always include the serial number, model number and a code letter to ensure proper replacement parts.
  3. Check again to be sure all installation procedures have been completed.

## COOKTOP INSTALLATION WITH A 36" MONOGRAM DOWNDRAFT VENT

The installation of the downdraft vent with this cooktop requires careful consideration. Both the cooktop and the vent must be installed according to each specific installation instruction.

## BASE CABINET REQUIREMENTS

The combined installation will fit in a standard 24" deep base cabinet. Use a 36" or wider base cabinet. —The vent housing, blower and ductwork will occupy the base cabinet.

## COOKTOP REQUIREMENTS

The countertop must have a deep flat surface to accommodate the cooktop and vent. Countertops with a rolled front edge and backsplash will not provide the flat surface area required.

- Review the illustration to determine the countertop surface requirements.

—All cutout clearances for this installation must be observed.

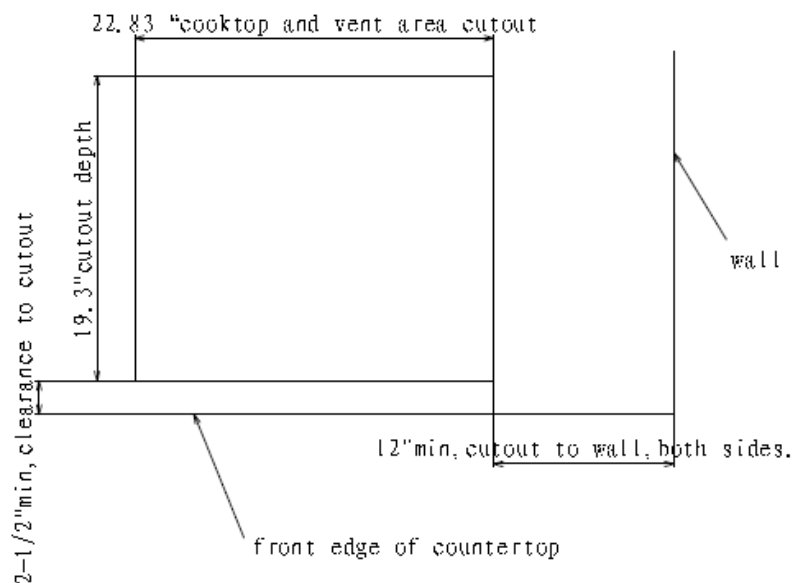

12" min, cutout to wall, both sides.

2-1/2" min, clearance to cutout

22.83 " cooktop and vent area cutout

19.3" cutout depth

22.8" X 19.3" depth cut out

## **POWER SUPPLY**

If local codes permit, the vent and cooktop may operate from the same 120V, 15 amp duplex outlet. Locate the gas and electrical supply as shown on page 8.

## **COOKTOP INSTALLATION OVER A 30" MONOGRAM SINGLE OVEN**

These cooktops may be installed over the Monogram single oven. Both the cooktop and the oven must be installed according to each specific installation instruction.

Allow 4" Min. clearance from the top of the countertop to the top of the oven cutout.

Use a 36" or wider base cabinet.

- For best appearance, the cooktop should be centered over the oven.

**POWER SUPPLY:** The oven requires a separate, properly grounded 20 Amp, 3-wire 208 or 240 volt, 60 Hz power supply. The cooktop requires a separate 120V power supply. See page 8. Where codes permit, the gas shut-off valve may be located in an adjacent cabinet or other easily accessible location.

## **Convert Natural Gas to LP Gas Operation**

**If sold outside the U.S. and Canada:**



**WARNING:** If you wish to use this product with Liquefied Petroleum (LP) gas containing greater than 10% butane, you must purchase the butane conversion kit [#WB28T10237](#). To order, please call [\(888\)664-8403](#) or [\(787\)276-4051](#).

### **SAFETY INFORMATION**

The pressure regulator and burner orifices are set for natural gas operation.

To convert this cooktop from natural gas operation to LP operation, the regulator and burner orifices must be converted. LP burner orifices are attached to the regulator.



**CAUTION** — The cooktop, as shipped from the factory, is set for use with its intended gas. If you wish to use your cooktop with the alternate gas, you must first replace the orifices and convert the pressure regulator.



**WARNING** — This conversion must be performed by a qualified installer or gas supplier in accordance with the manufacturer's instructions and all codes and requirements of the authority having



jurisdiction. Failure to follow instructions could result in serious injury or property damage. The qualified agency performing this work assumes responsibility for the conversion.

**⚠ CAUTION** — The following adjustments must be made before turning on the burner. Failure to do so could result in serious injury. Be sure pressure regulator has been converted as described in Step 1.

#### TOOLS YOU WILL NEED FOR CONVERSION

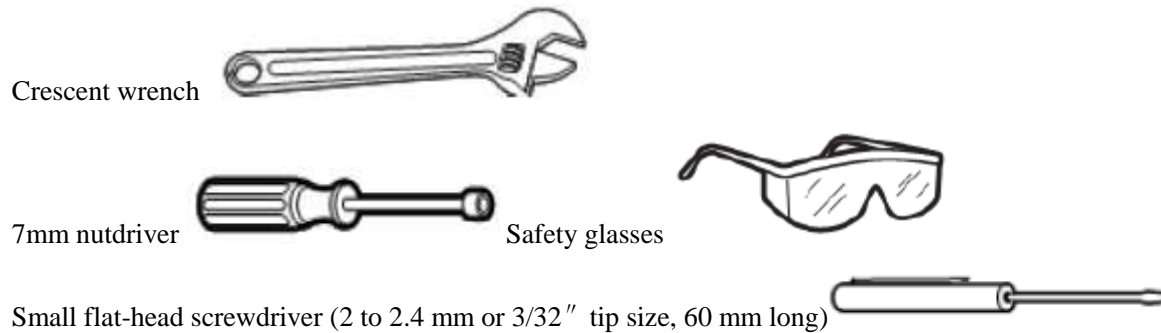

#### ADJUST THE REGULATOR

- A. Disconnect all electrical power, at the main circuit breaker or fuse box.
- B. Shut off the gas supply to the cooktop by closing the manual shut-off valve
- C. Adjust the pressure regulator by the following instructions:



Unscrew the cap with a Crescent wrench.



NG position.



Take out the retainer.



LP position



## 2 CHANGE BURNER ORIFICES

INSTALLATION TIP: First remove all orifices and then start replacing them. This will help to prevent the possibility that some may not be replaced.

A. Remove the burner grates, burner caps and burner heads.

B. Using a 7mm nut driver, remove the top burner orifices. There are two orifices per burner.

The main orifice is located low in the center of the burner, while the simmer orifice is located higher beside the center of the burner.

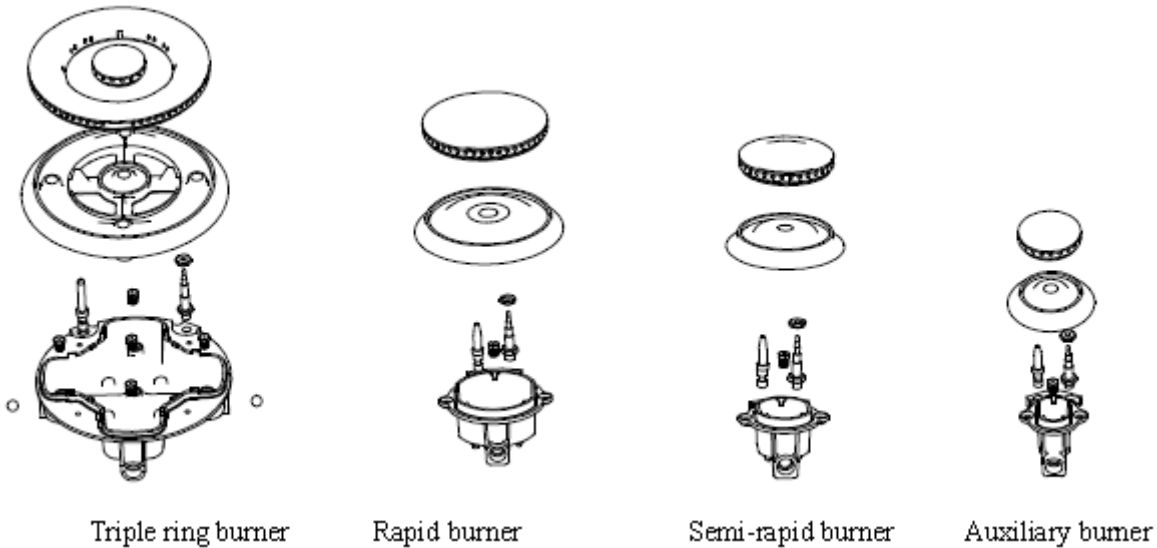

**IMPORTANT:** Orifices must be located exactly as shown. Carefully read and observe each orifice label for correct location.

**C. Install the proper orifices in the exact locations as noted in the illustrations above.**

**D. Return the natural gas orifices to the bracket and reattach the bracket and the instruction sheet to the pressure regulator using the screw removed previously.**

**E. Replace the burner bases, heads, caps and top grates.**

### 3 ADJUST BURNER FLAMES

A. Turn all burners on highest setting and check the flames. They should be blue in color and may have some yellow tipping at the ends of the flame when using LP gas. Foreign particles in the gas line may cause an orange flame at first, but this will soon disappear.

B. Turn the cooktop burner knob to “LO” while observing the flame.

Adjust the setting of the upper row of flames using the valve bypass screw as follows:

Adjustments must be made with two other burners in operation on a medium setting. This prevents the upper row of flames from being set too low, resulting in the flame being extinguished when other burners are turned on.

C. To adjust the flame, remove the knobs. Insert a screwdriver through the access hole in valve shaft as shown.

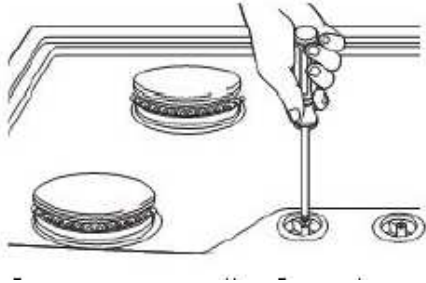

- If the flames were too small or fluttered, open the valve more than the original setting.
- If the flames blew away from the burner, close the valve more than the original setting.

D. Make the adjustment by slowly turning the screw until flame appearance is correct.

#### E. Testing Flame Stability:

**Test 1**—Turn the knob from “HI” to “LO” quickly. If the upper row of flames goes out at this setting, increase the flame size and test again.

**Test 2**—With the burner on “LO”, open and close the cabinet door under the cooktop. If the flame is extinguished by the air currents created by the door movement, increase the flame height and test again.

NOTE: When the burner is on the “SIM” setting, the upper row of flames will go out.

#### F. Flame Recheck:

After the adjustment is made, turn all burners off. Ignite each burner individually. Observe the flame at the “HI” position. Rotate the knob to the lowest setting and be sure that the flame size decreases as the knob is rotated counterclockwise.

**Once the conversion is complete and checked ok, fill out the conversion sticker and include your name, organization and date conversion was made. Apply the sticker near the cooktop gas inlet opening to alert others in the future that this appliance has been converted. If converting back to the original gas, please remove the sticker so others know the appliance is set to use its original gas.**

## Convert LP Gas to Natural Gas Operation

**If sold outside the U.S. and Canada:**



**WARNING:** If you wish to use this product with Liquefied Petroleum (LP) gas containing greater than 10% butane, you must purchase the butane conversion kit #WB28T10237. To order, please call (888)664-8403 or (787)276-4051.

#### SAFETY INFORMATION

The pressure regulator and burner orifices are set for natural gas operation.

To convert this cooktop from natural gas operation to LP operation, the regulator and burner orifices must be converted. LP burner orifices are attached to the regulator.

**⚠ CAUTION** — The cooktop, as shipped from the factory, is set for use with its intended gas. If you wish to use your cooktop with the alternate gas, you must first replace the orifices and convert the pressure regulator.

**⚠ WARNING** — This conversion must be performed by a qualified installer or gas supplier in accordance with the manufacturer’s instructions and all codes and requirements of the authority having jurisdiction. Failure to follow instructions could result in serious injury or property damage. The qualified agency performing this work assumes responsibility for the conversion.

**⚠ CAUTION** — The following adjustments must be made before turning on the burner. Failure to do so could result in serious injury. Be sure pressure regulator has been converted as described in Step 1.

### TOOLS YOU WILL NEED FOR CONVERSION

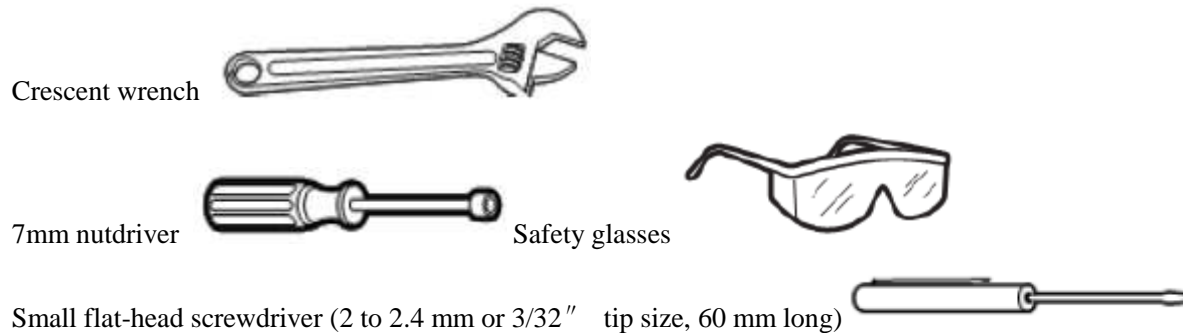

#### 1) ADJUST THE REGULATOR

- A. Disconnect all electrical power, at the main circuit breaker or fuse box.
- B. Shut off the gas supply to the cooktop by closing the manual shut-off valve
- C. Adjust the pressure regulator by the following instructions:



Unscrew the cap with a Crescent wrench.



NG position



Take out the retainer.



LP position



## 2) CHANGE BURNER ORIFICES

INSTALLATION TIP: First remove all orifices and then start replacing them. This will help to prevent the possibility that some may not be replaced.

A. Remove the burner grates, burner caps and burner heads.

B. Using a 7mm nut driver, remove the top burner orifices. There are two orifices per burner.

The main orifice is located low in the center of the burner, while the simmer orifice is located higher beside the center of the burner.

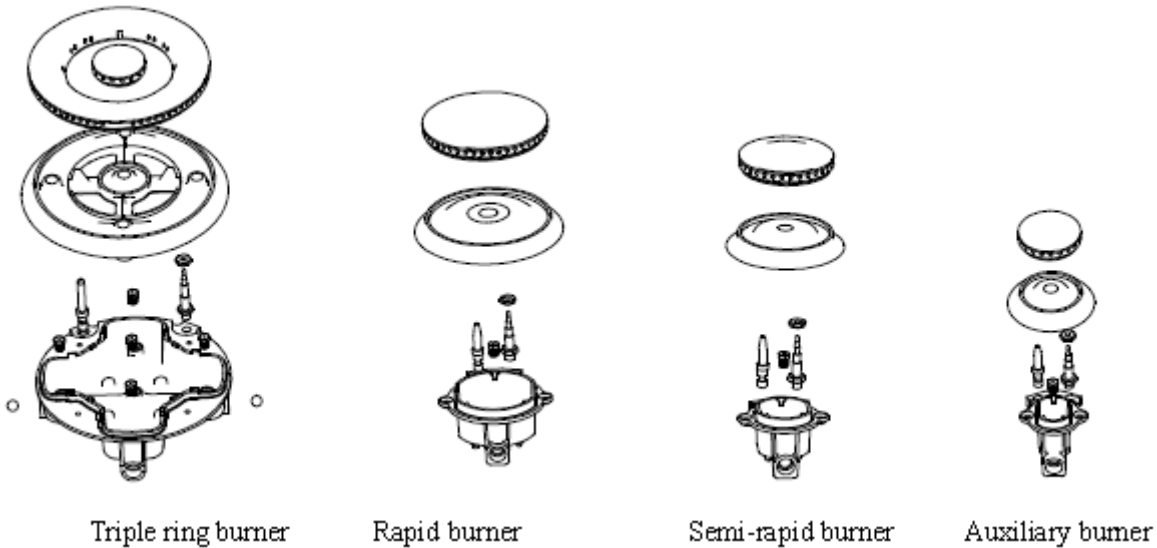

**IMPORTANT:** Orifices must be located exactly as shown. Carefully read and observe each orifice label for correct location.

**C. Install the proper orifices in the exact locations as noted in the illustrations above.**

**D. Return the natural gas orifices to the bracket and reattach the bracket and the instruction sheet to the pressure regulator using the screw removed previously.**

**E. Replace the burner bases, heads, caps and top grates.**

### 3) ADJUST BURNER FLAMES

A. Turn all burners on highest setting and check the flames. They should be blue in color and may have some yellow tipping at the ends of the flame when using LP gas. Foreign particles in the gas line may cause an orange flame at first, but this will soon disappear.

B. Turn the cooktop burner knob to “LO” while observing the flame.

**Adjust the setting of the upper row of flames using the valve bypass screw as follows:**

Adjustments must be made with two other burners in operation on a medium setting. This prevents the upper row of flames from being set too low, resulting in the flame being extinguished when other burners are turned on.

C. To adjust the flame, remove the knobs. Insert a screwdriver through the access hole in valve shaft as shown:

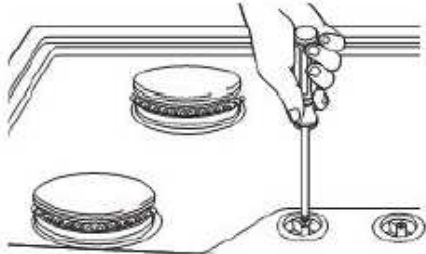

- If the flames were too small or fluttered, open the valve more than the original setting.
- If the flames blew away from the burner, close the valve more than the original setting.

D. Make the adjustment by slowly turning the screw until flame appearance is correct.

#### E. Testing Flame Stability:

**Test 1**—Turn the knob from “HI” to “LO” quickly. If the upper row of flames goes out at this setting, increase the flame size and test again.

**Test 2**—With the burner on “LO”, open and close the cabinet door under the cooktop. If the flame is extinguished by the air currents created by the door movement, increase the flame height and test again.

NOTE: When the burner is on the “SIM” setting, the upper row of flames will go out.

#### F. Flame Recheck:

After the adjustment is made, turn all burners off. Ignite each burner individually. Observe the flame at the “HI” position. Rotate the knob to the lowest setting and be sure that the flame size decreases as the knob is rotated counterclockwise.

**Once the conversion is complete and checked ok, fill out the conversion sticker and include your name, organization and date conversion was made. Apply the sticker near the cooktop gas inlet opening to alert others in the future that this appliance has been converted. If converting back to the original gas, please remove the sticker so others know the appliance is set to use its original gas.**



## Solutions to common problems

Before calling for service, review this list. It may save you time and expenses. This list includes Common experiences that are nor the result of defective workmanship or materials in your cooktop.

FAQs	Possible Reasons		Solutions
No spark when lighting burner	Electrical supply	The electrical wires or the plug are not connected well.	Connect with electrical power again.
	Burner	The burner is not installed correctly.	Install the burner again.
	Spark pin	Ignition electrode and the hole are not placed well.	Adjust the distance for 3- 4m m
The spark pin is broken.		Replace the broken spark pin.	
The fire goes out once release the knob	Safety valve	Knob not pressed down long enough.	Press and turn the knob again and keep 3 to 5 seconds after the burner has been lit.
Burner won't ignite or burns unevenly	Gas valve	The valve is not open or totally open.	Make sure the valve is completely open.
	Gas pipe	There may be air in the gas pipe.	Ignite repeatedly until flame catches.
	Burner cap	The burner cap is not placed correctly.	Replace the burner cap.
		Some holes in the lid are stocked.	Clean the holes of the lid.
	Spark pin	The spark pin is wet or contaminated by the food.	Clean and dry the spark pin..
Gas connecting pipes	The gas connecting pipes are stocked or squashed.	Adjust or change the connecting pipes.	
The flame goes out during operation	Thermocouple	The safety device is contaminated.	Clean the thermocouple.
		The flame is so little that it can't touch the thermocouple.	Adjust the flame a little bigger.
Strange smell	Gas leaking	The gas supply pipe is old and broken.	Change the gas supply pipe.
		The main burner is not lit.	Ignite again after there is no strange smell.