

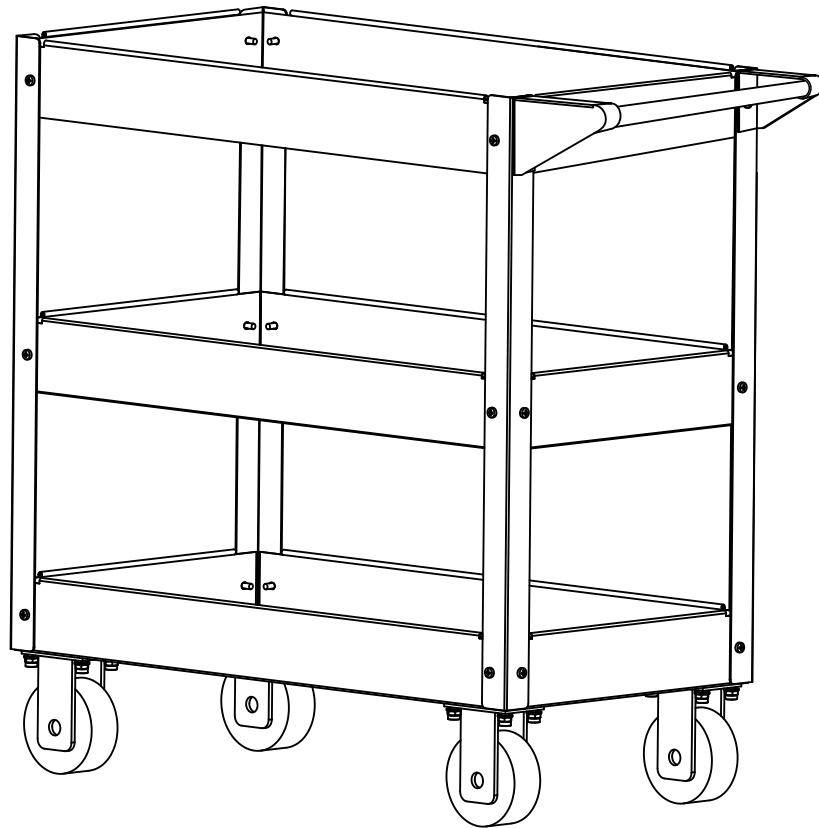

3-Tray Tool Cart

Model No: TC301



IMPORTANT:
Please read this manual before using this
tool cart and save it for reference.

**INSTRUCTION
MANUAL**



- To reduce the risk of serious injury, read the following safety instructions before assembling and using the cart
- The product should be positioned on a level surface.
- Any assembly or maintenance of the product must be carried out by adults only.
- Arrange for necessary manpower when assembling and moving the cart.
- Check all nuts and bolts periodically for tightness. When required, tighten them again.
- Do not exceed the following weight limits for this product.
Maximum load: 165 lb (75 kg)
Maximum load for each castor: 100 lb (45.5 kg).

NOTE: If any parts are missing or damaged, or if you have any questions, please send a Email to customerservice@xindadi.com.



SAVE THESE INSTRUCTIONS.

This manual contains important safety and operating instructions.
Read all instructions and follow them with use of this product.

SPECIFICATIONS

Maximum Load	165 lb (75 kg)
Maximum Load For Each Castor	100 lb (45.5 kg)
Gross Weight	34 lb (15.6 kg)

Max
165 lb
(75 kg)

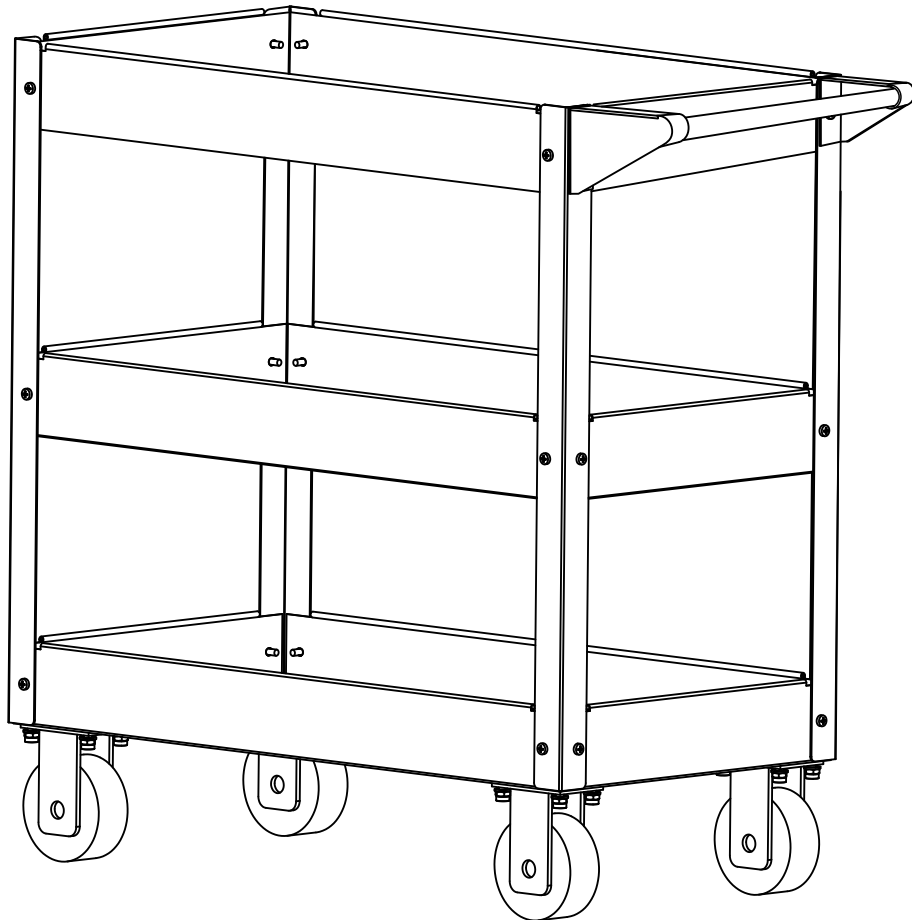
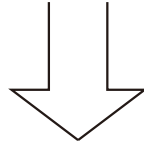

KEY PARTS DIAGRAM

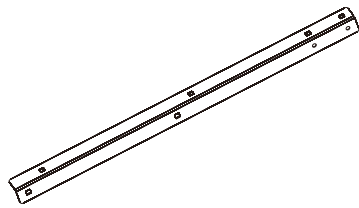

A) Leg 4 PCS

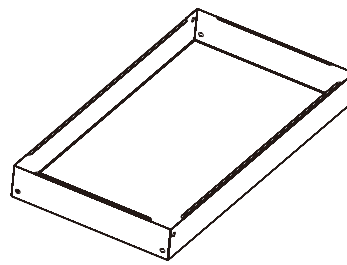

B) tray 3 PC

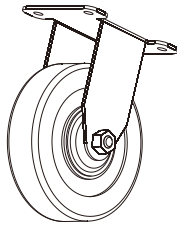

C) Fixed castor 2 PCS

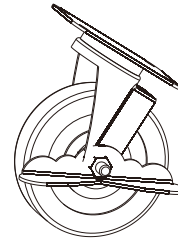

D) Swivel castor
2 PCS with brake

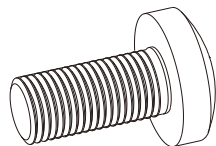

E) Bolt M6 x 12 24 PCS

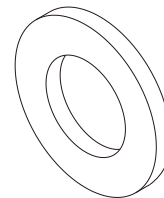

F) Washer M8 16 PCS

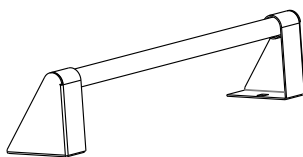

G) Handle 1PC

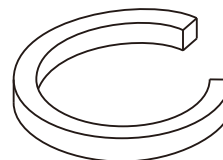

H) Spring washer 16pcs

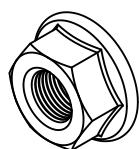

I) Nut M8 40 PCS

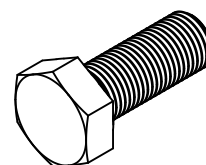

J) Bolt M8 x 16 16PCS

ASSEMBLY

1. Mount the castors to the bottom tray. Bolt the two fixed castors (C) to one side of the bottom tray (B) with eight M8 x 16 bolts (J), eight M8 washers (F) and eight M8 nuts (I) and eight Spring washer (H). Bolt the two swivel castors (D) to the other side of the tray with eight M8 x 16 bolts (J), eight M8 washers (F) and eight M8 nuts (I) and eight Spring washer.

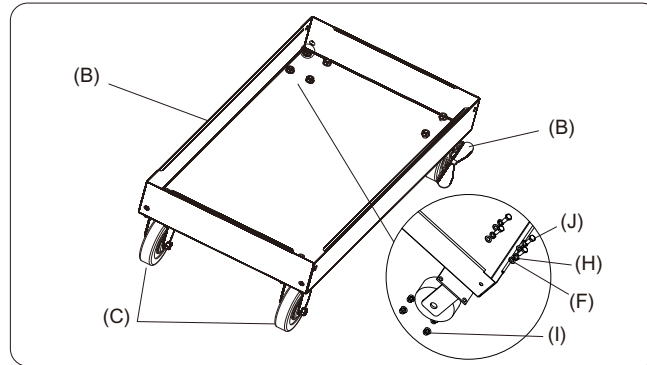

2. Attach the four upright legs (A) to the bottom tray (B) with eight bolts (E) and eight M6 nuts (I) as shown below. Ensure the legs (A) are attached to the outside of the bottom tray (B). Ensure the legs are in the right direction with the two holes at the bottom and six holes on the top.

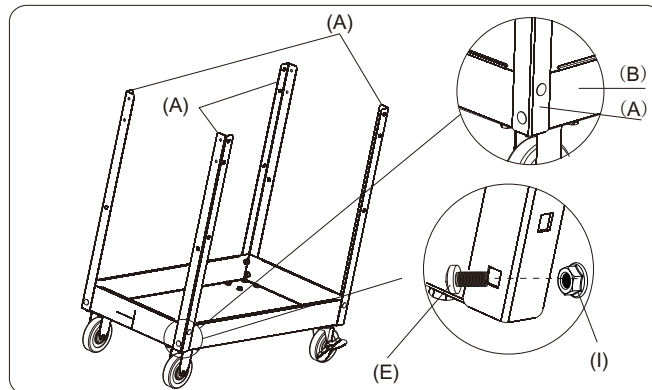

3. Put the middle tray (B) in the middle of the four legs and fix it with eight bolts (E) and eight M6 nuts (I) as shown below.

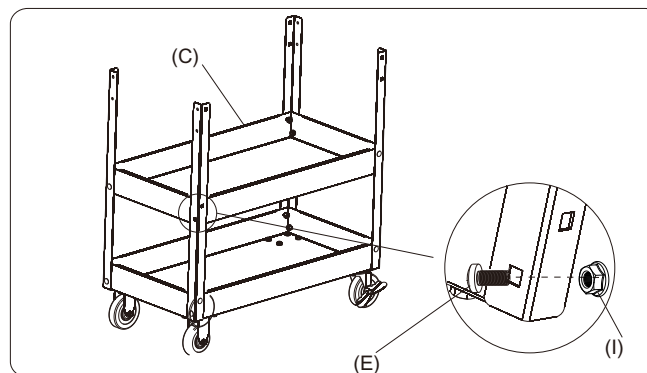

Note: The assembly screws for the legs and trays should be loosely fastened during assembly, then fully tightened once all legs and trays are assembled.

4. Put the top tray (B) on the top of the four legs.

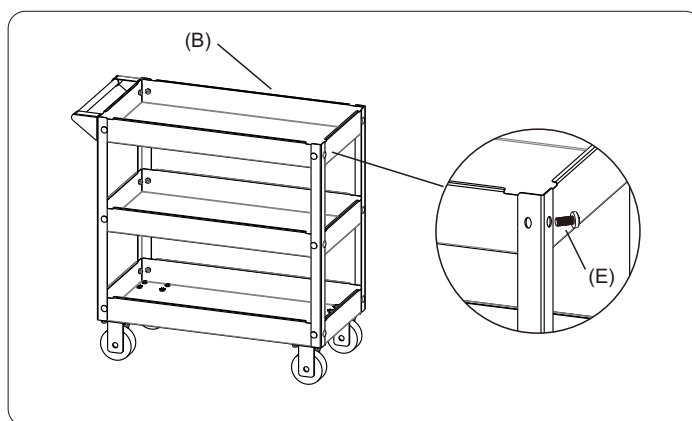

5. Attach the handle (G) to the end with the swivel castors (D) using two bolts and two nuts (I).

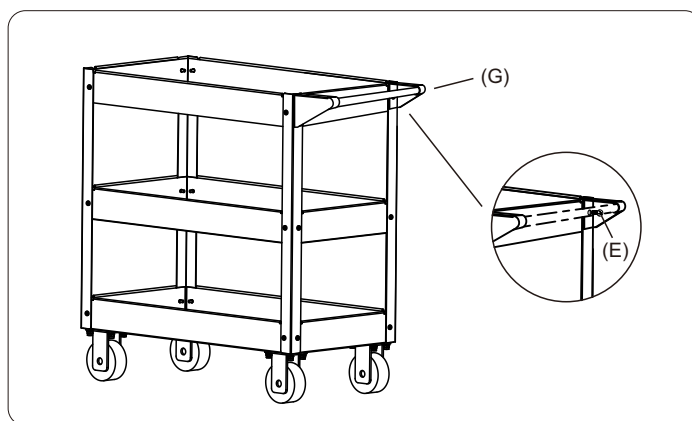

SAFETY WARNINGS AND CAUTIONS

DO NOT stand on this product . You may fall which may cause personal injury. When moving this product, do not pull it. Push the product to prevent personal injury.

- ▶ BE CAREFUL when opening the drawer. The product may become unstable and tip, which may cause personal injury or product damage.
- ▶ DO NOT mount this product on a truck bed or any other moving object. This may cause personal injury or product damage.
- ▶ DO NOT step in/on the drawer. You may fall which may cause personal injury. Appropriately secure this product before moving it with a forklift.
- ▶ DO NOT tow with power equipment. The product could tip, which may cause personal injury or product damage .
- ▶ DO NOT alter this product in any manner. For example, do not weld external lockbars or attach electrical equipment. This may cause product damage or personal injury. Keep the product on level surfaces. The product may become unstable and tip if stored or moved on an unlevel surface, which may cause personal injury or product damage .

Warranty

This Mastercraft product carries a one (1) year warranty against defects in workmanship and materials. This product is not guaranteed against wear or breakage due to misuse and/or abuse.

Distributed by: XDD Products(USA),LLC
3411 North Hutchinson,Pine Bluff.AR 71602.
Made in China