







S-6610-1.5, S-6612-1.5
Single Handle Centerset Lavatory Faucet
Operation & Maintenance Manual



<p>Model Numbers</p> <ul style="list-style-type: none"> <input type="checkbox"/> S-6610-1.5 <i>Unity Single Handle Centerset Lavatory Faucet Less Rod</i> <input type="checkbox"/> S-6612-1.5 <i>Unity Single Handle Centerset Lavatory Faucet</i> 	<p>Specification</p> <p>Single handle centerset lavatory faucet featuring a 4" mounting configuration. Includes ceramic cartridge, 1/4" copper supply lines, 1/2" IPS inlet connections, 50/50 drain assembly and standard 1.5 gpm (5.7 L/min) aerator. Components made from brass and nonmetallic materials plated in standard polished chrome finish.</p> 
<p>Modifications</p> <ul style="list-style-type: none"> <input type="checkbox"/> -0.5  <i>0.5 gpm (1.9 L/min) aerator</i> <input type="checkbox"/> -1.0  <i>1.0 gpm (3.8 L/min) aerator</i> <input type="checkbox"/> -G <i>Grid drain</i> <input type="checkbox"/> -Delete Suffix 1.5 <i>2.2 gpm (8.3 L/min) aerator</i> <input type="checkbox"/> -STN <i>Satin Nickel finish</i> <p>Note: Append appropriate -suffix to model number.</p>	<p>Compliance</p> <ul style="list-style-type: none"> -NSF/ANSI 372, NSF/ANSI 61.9 -ASME A112.18.1/CSA B125.1 -WaterSense 1.5 gpm (5.7 L/min)   <p>Warranty</p> <p>Limited Lifetime - to the original end purchaser in consumer/residential installations. 5 Years - for industrial/commercial installations. Refer to www.symmons.com/warranty for complete warranty information.</p>

Dimensions

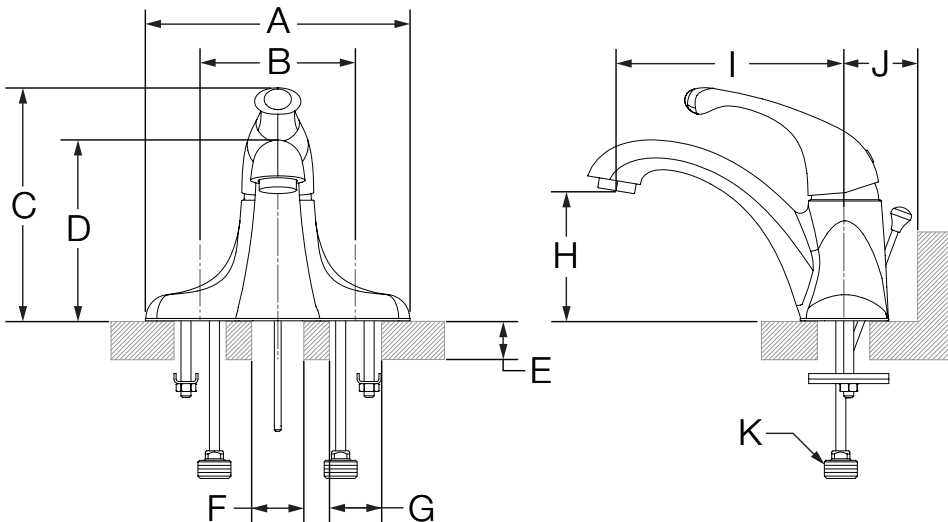

Measurements	
A	6 5/8", 168 mm
B	3 3/8", 86 mm
C	5 7/8", 149 mm
D	4 1/2", 114 mm
E	Deck Thickness Ref. Max. 1 3/8", 35 mm
F	Hole Size Ø 1 3/8", 35 mm
G	(2x) Hole Size Ø 1 1/2", 38 mm
H	3 1/4", 83 mm
I	5 3/4", 146 mm
J	Min. 2 1/2", 64 mm
K	1/2-14 NPSM

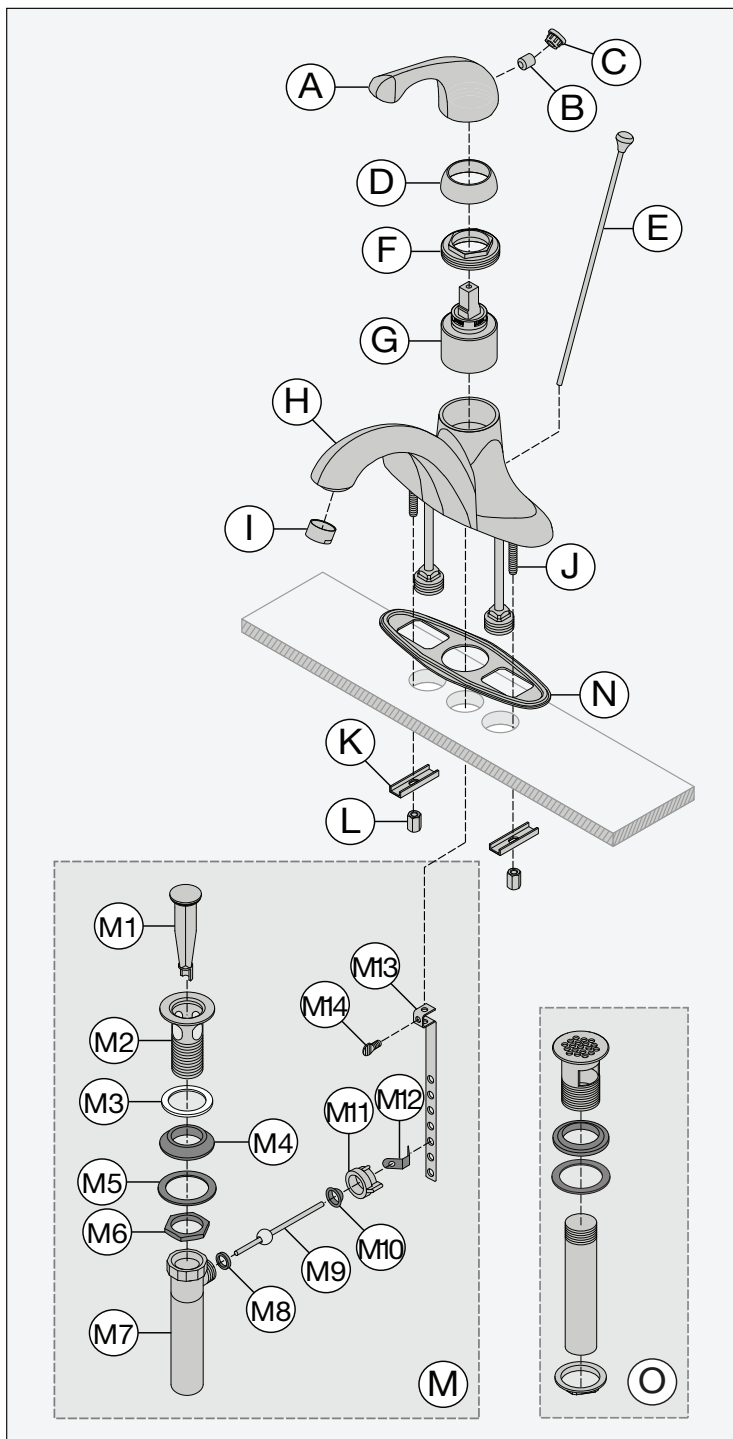

Note: Dimensions subject to change without notice.

Parts Breakdown

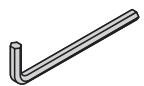

Replacement Parts		
Item	Description	Part Number
A B C	Handle Kit	RL-212*
E	Lift Rod	RL-213*
G	Cartridge	KN-4
K L N	Mounting Hardware	RL-214
I	Aerator	RL-015-2.2 (2.2) RL-015-1.5 (1.5) RL-015-1.0 (1.0) RL-015-0.5 (0.5)
M	50/50 Drain Assembly	RL-223* (S-6612-1.5)
O	Grid Drain	P-26* (S-6610-1.5)

***Note:** Append -STN to part number for Satin Nickel finish.

Tools Required	
Adjustable wrench	
Allen wrench (3/32")	
Plumber putty	
Plumber tape	

Installation

! If replacing an older faucet ensure water supply is turned OFF before removing, then turn faucet control valve ON to relieve water pressure.

1) Insert faucet body (H) and threaded rods (J) through mounting gasket (N) and sink holes.

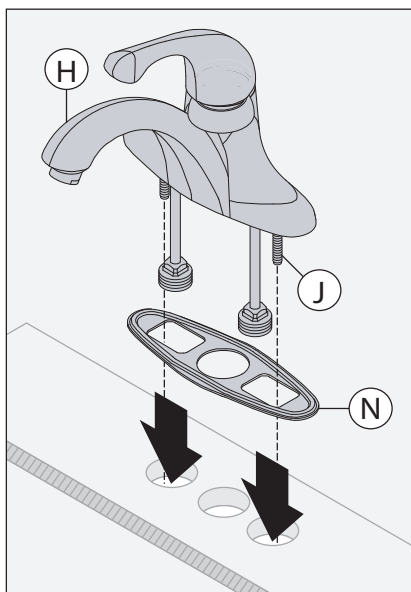

2) Place brackets (K) onto threaded rods (J) and secure with nuts (L).

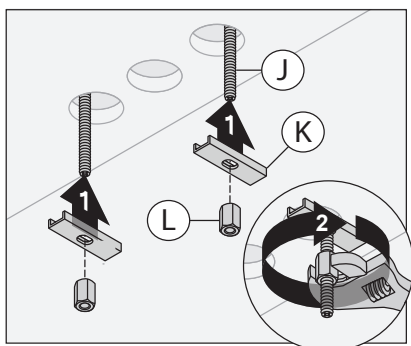

3) Seat flange (M2) into sink (M3 gasket optional). Install gasket (M4), washer (M5) and nut (M6) onto flange (M2) from below sink, but do not secure nut. Screw on tail piece (M7) and hand tighten.

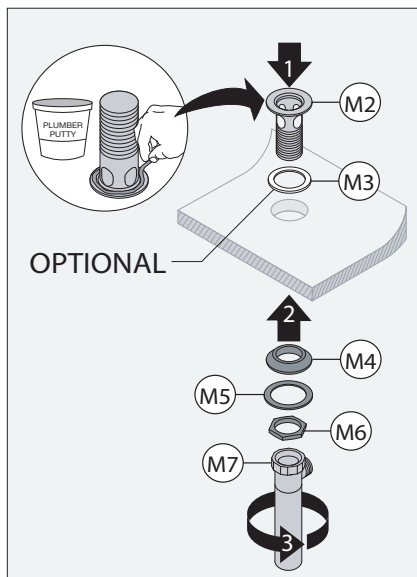

4) Turn tail piece (M7) and flange (M2) so pivot is facing toward faucet. Pull assembly down into drain hole. Secure hardware from below sink. Install stopper (M1) in the removable or non-removable position.

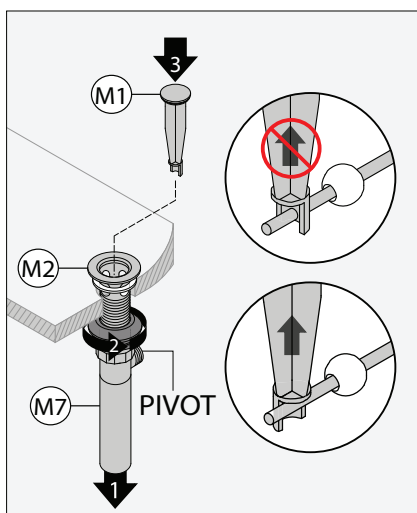

5) Attach inner washer (M8), pivot rod (M9) and outer washer (M10) to tailpiece (M7). Hand tighten nut (M11) to secure pivot rod (M9).

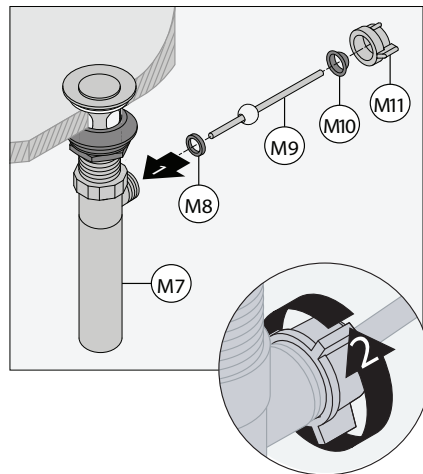

6) Connect lift rod (E) to clevis strap (M13) and secure with thumb screw (M14). Insert pivot rod (M9) through spring clip (M12) and clevis strap (M13). Secure with spring clip (M12) and adjust linkage if necessary.

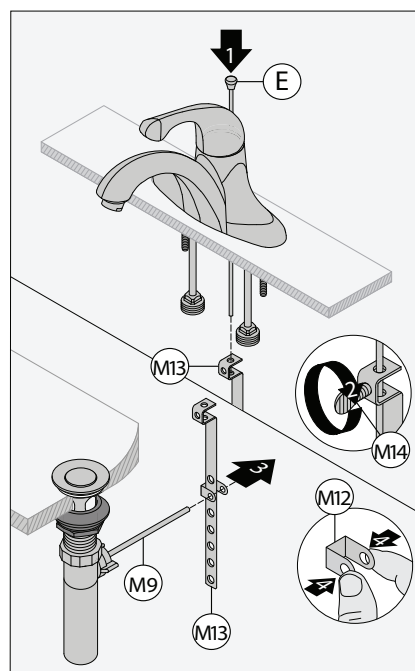

Installation

- 7) Attach supply lines to 1/2" IPS inlet connections on faucet body (H). Using a wrench, finish with one half turn. **DO NOT** overtighten.

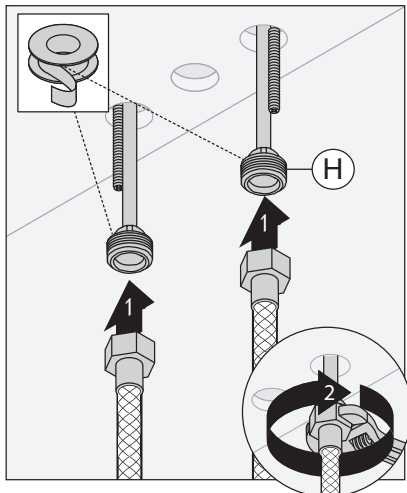

- 8) Attach supply lines to shut-off valves and hand tighten. Using a wrench, finish with one-half turn. **DO NOT** overtighten.

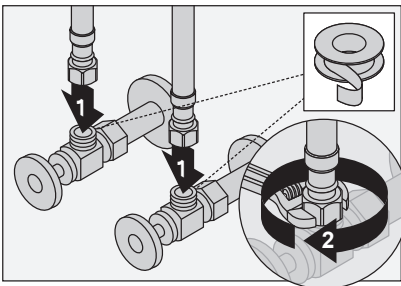

- 9) Remove aerator (I) and flush lines free of debris. Check for leaks.

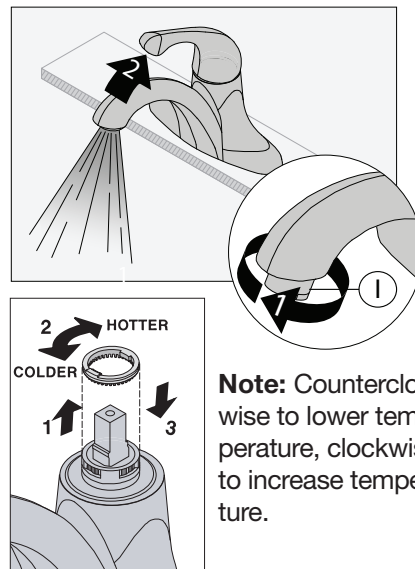

Note: Counterclockwise to lower temperature, clockwise to increase temperature.

Maintenance

- 1) Remove plug button (C) and set screw (B). Turning counterclockwise, disassemble handle (A), collar (D) and nut (F) from cartridge (G).

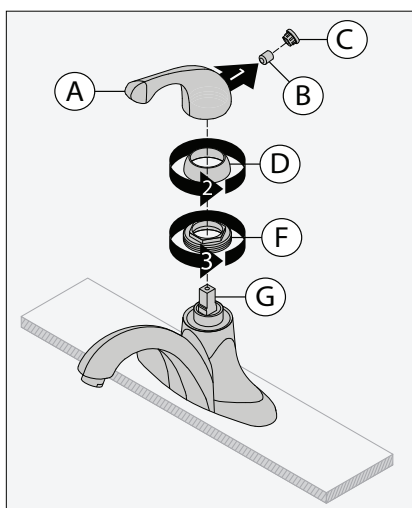

- 2) Remove cartridge (G) from faucet body (H). Inspect for debris. Replace cartridge if necessary.

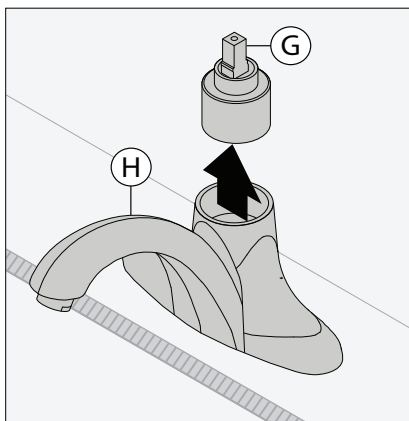

- 3) Correctly align cartridge (G) and insert into faucet body (H). Install handle assembly following step 1 in reverse.

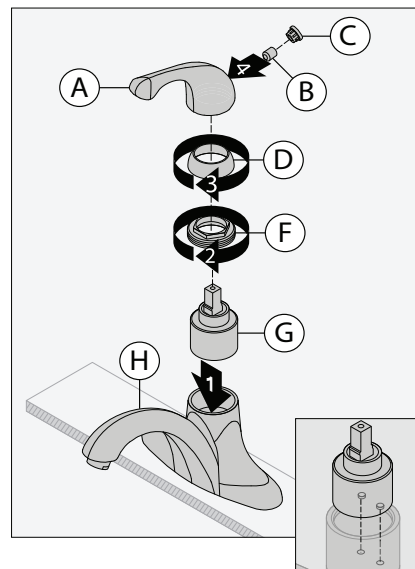

Troubleshooting Chart





Finish is spotting.

Elements in water supply may cause water staining on finish.

Clean finished trim area with a soft cloth using mild soap and water or a non-abrasive cleaner and then quickly rinse with water.

Manual de Operación y Mantenimiento



Números de modelo	Especificación
<input type="checkbox"/> S-6610-1.5 Sola manija para lavamanos Unity sin biela de elevación <input type="checkbox"/> S-6612-1.5 Sola manija para lavamanos Unity	Sola manija para lavamanos que ofrecen una configuración de 4 "de montaje. Incluye cartuchos cerámicos, conexiones 1/2" IPS de entrada, 50/50 conjunto de drenaje y 1.5 gpm (5,7 l / min) aireador estándar. Componentes hechos de latón y materiales no metálicos chapados en acabado cromo brillo estándar. 
Modificaciones	Cumplimiento
<input type="checkbox"/> -0.5  Aireador de 0.5 gpm (1.9 L/min) <input type="checkbox"/> -1.0  Aireador de 1.0 gpm (3.8 L/min) <input type="checkbox"/> -G Desagüe de rejilla <input type="checkbox"/> -Delete Suffix 1.5 Aireador de 2.2 gpm (8.3 L/min) <input type="checkbox"/> -STN Acabado en níquel satinado	-NSF/ANSI 372, NSF/ANSI 61.9 -ASME A112.18.1/CSA B125.1 -WaterSense 1.5 gpm (5.7 L/min)  
<p>Nota: Anexar el -complemento apropiado al número de modelo.</p>	Garantía Limitada de por vida - para el comprador original en instalaciones para el consumidor/residenciales. 5 años - para instalaciones industriales/comerciales. Consulte www.symmons.com/warranty para obtener información completa sobre la garantía.

Dimensiones

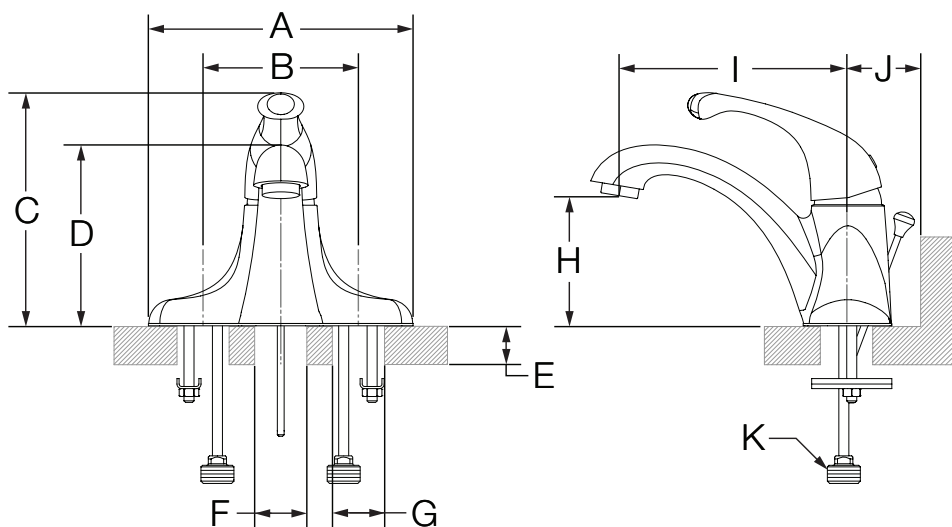

Medidas	
A	6 5/8", 168 mm
B	3 3/8", 86 mm
C	5 7/8", 149 mm
D	4 1/2", 114 mm
E	Referencia del grosor de la cubierta Máx. 1 3/8", 35 mm
F	Tamaño del orificio Ø 1 3/8", 35 mm
G	Tamaño del orificio (2x) Ø 1 1/2", 38 mm
H	3 1/4", 83 mm
I	5 3/4", 146 mm
J	Mín. 2 1/2", 64 mm
K	1/2-14 NPSM

Nota: Las dimensiones pueden cambiar sin previo aviso.

Desglose de piezas

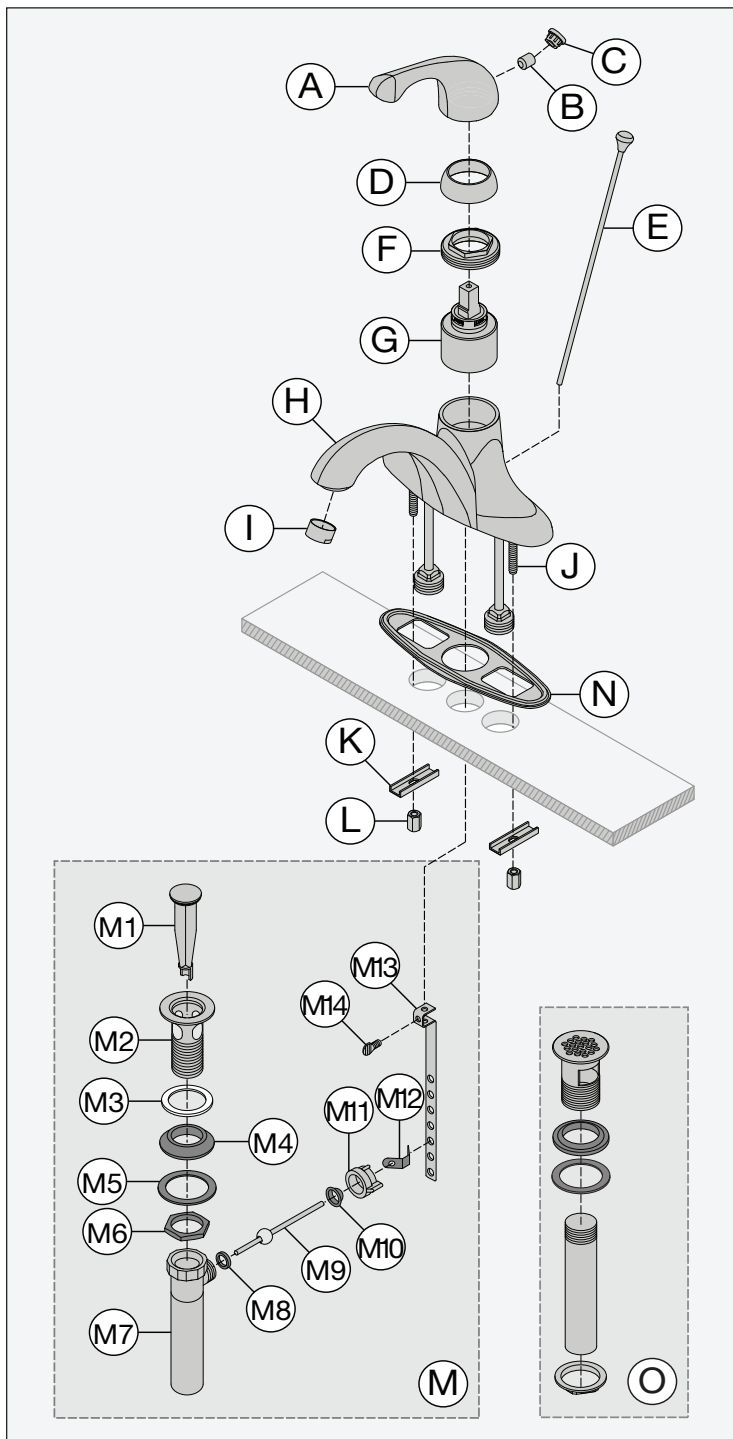

Repuestos		
Artículo	Descripción	Número de pieza
A B C	Juego de manijas	RL-212*
E	Varilla de levantamiento	RL-213*
G	Cartucho	KN-4
K L N	Hardware de montaje	RL-214
I	Aireador	RL-015-2.2 (2.2) RL-015-1.5 (1.5) RL-015-1.0 (1.0) RL-015-0.5 (0.5)
M	Ensamble del desagüe 50/50	RL-223* (S-6612-1.5)
O	Desagüe de rejilla	P-26* (S-6610-1.5)

***Nota:** Anexar -STN al número de pieza para el acabado en níquel satinado.

Herramientas requeridas	
Llave inglesa	
Llave Allen (3/32")	
Masilla de plomero	
Cinta de plomero	

Instalación



Si está reemplazando otro grifo, asegúrese de que el suministro de agua esté **CERRADO** antes de quitarlo, luego **ABRA** la válvula de control del grifo para liberar la presión de agua.

- 1) Inserte el cuerpo del grifo (H) y varillas roscadas (J) a través de la placa de masilla (N) y de la placa de la plataforma.

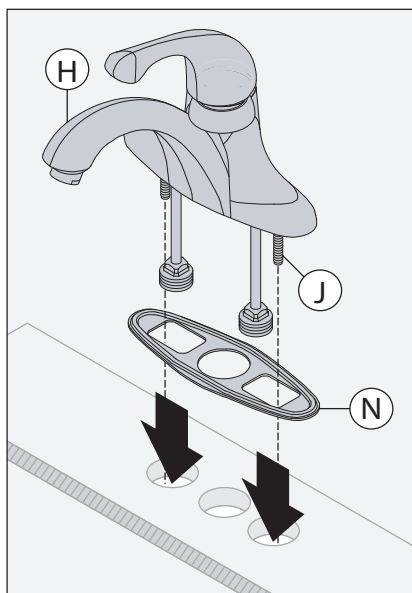

- 2) Coloque los sujetadores (K) en las varillas roscadas (J). Sujételos con tuercas (L).

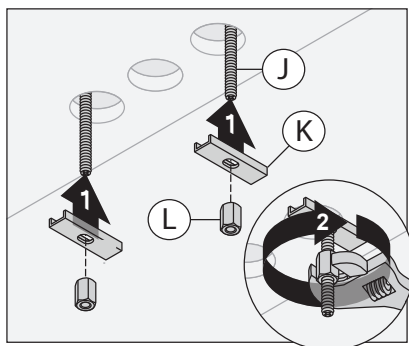

- 3) Ajuste la brida (M2) al lavabo (M3, junta opcional). Instale la junta (M4), la arandela (M5) y la tuerca (M6) en la brida (M2) desde debajo del lavabo, pero no ajuste la tuerca. Atornille la rejilla (M7) y ajuste con la mano.

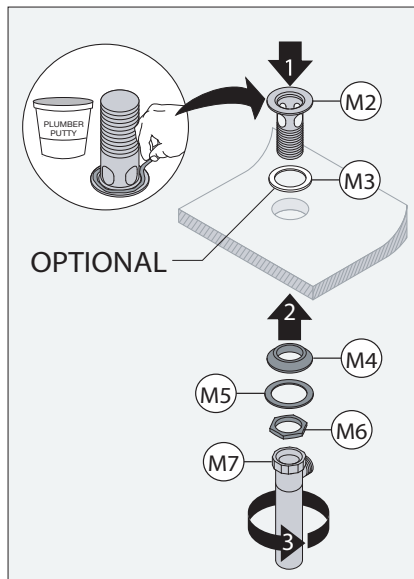

- 4) Gire la rejilla (M7) y la brida (M2) para que el pivote mire hacia el grifo. Jale el ensamble hacia abajo dentro del orificio de desagüe. Asegure el hardware al ensamble desde abajo del lavabo. Instale el obturador (M1) en la posición extraíble o no extraíble.

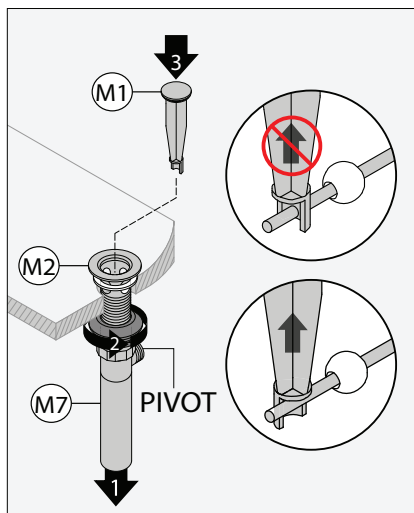

- 5) Sujete la barra de pivote (M9) a la rejilla (M7). Ajuste la tuerca (M11) a mano en el sentido de las agujas del reloj para asegurar la barra de pivote (M9).

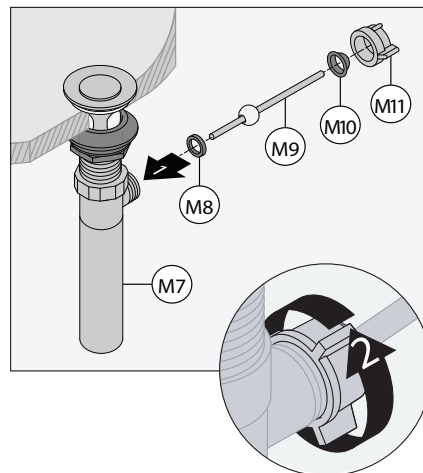

- 6) Conecte la varilla de levantamiento (E) a la barra con horquilla (M13) y asegure con una tuerca de orejas (M14). Inserte la barra de pivote (M9) en la barra con horquilla (M13). Asegure con una grapa de resorte (M12) y ajuste la conexión si es necesario.

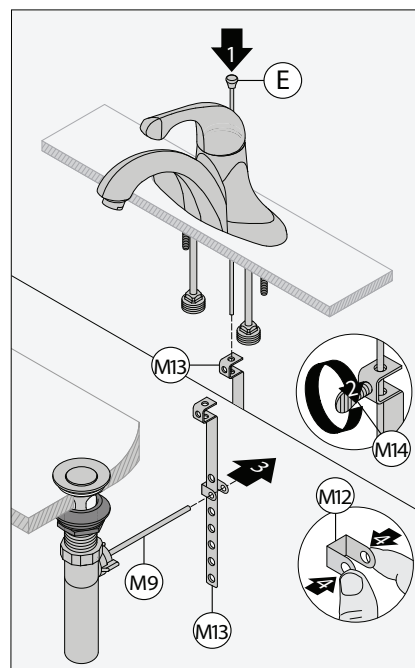

Instalación

7) Conecte las líneas de suministro a los conectores roscados del grifo (H) y apriételas a mano. Utilizando una llave, termine con media vuelta. **NO** apriete demasiado.

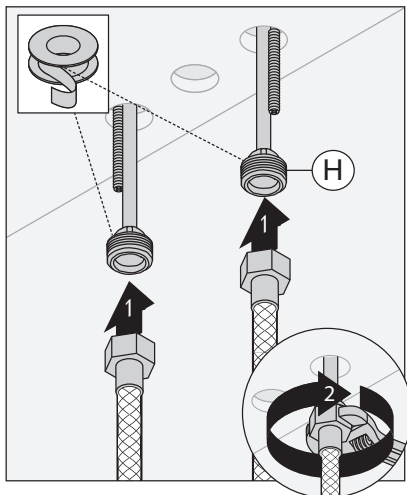

8) Aplique cinta de plomero para válvula de cierre. Utilizando una llave, termine con media vuelta. **NO** apriete demasiado.

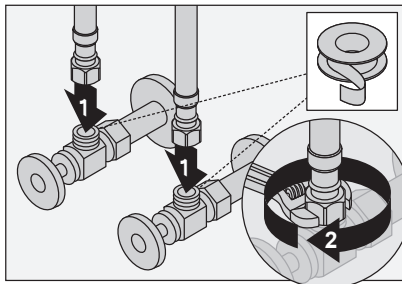

9) Extraiga el aireador (I) y enjuague las líneas para que queden libres de desechos. Verifique que si hay pérdidas.

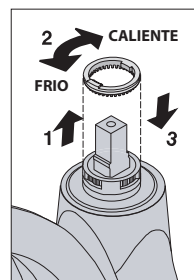
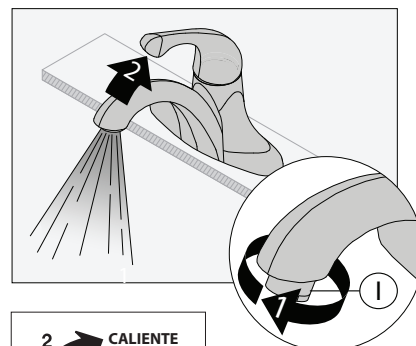

Nota: La izquierda para bajar temperatura, las agujas del reloj para aumentar la temperatura.

Mantenimiento

1) Retire botón del enchufe (C) y el tornillo de fijación (B). Volviendo hacia la izquierda, desmontar la manija (A), el montaje decorativo (D) y la tuerca (F) desde el cartucho (G).

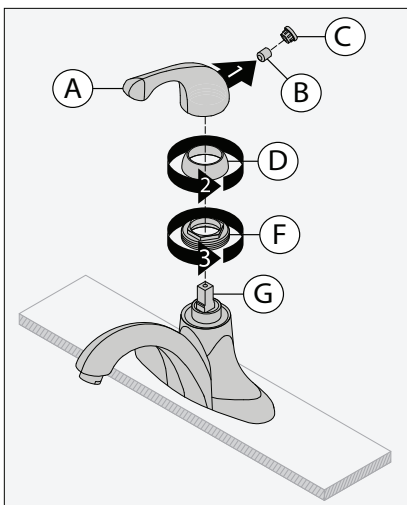

2) Extraiga el cartucho (G) del cuerpo de válvula (H). Inspeccione si hay desechos. Reemplace el cartucho si es necesario.

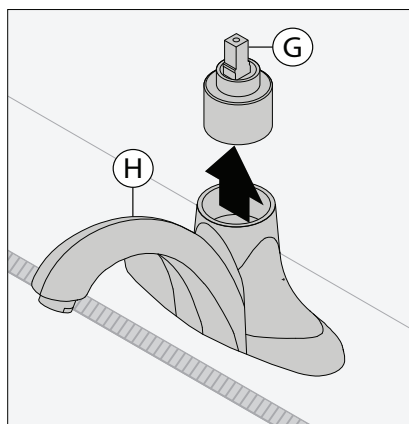

3) Correctamente Alinee el cartucho (G) e inserte en el cuerpo del grifo (H). Reemplace el cartucho siguiendo las instrucciones del paso 1 en sentido inverso.



Gráfico de resolución de problemas

El acabado mancha.

Los elementos del suministro de agua pueden provocar que el agua manche el acabado.



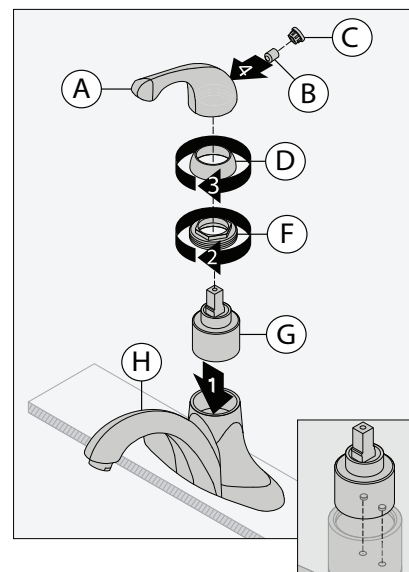

Limpie el área de reborde terminada con un paño y jabón suaves y agua, o un limpiador no abrasivo y luego enjuague rápidamente con agua.

S-6610-1.5, S-6612-1.5

Robinet de salle de bain monopiece à une poignée

Manuel d'Opération et de Maintenance



Numéro de modèle	Spécification
<input type="checkbox"/> S-6610-1.5 <i>Robinet de salle de bain monopiece à une poignée aucune tige de levage Unity</i> <input type="checkbox"/> S-6612-1.5 <i>Robinet de salle de bain monopiece à une poignée Unity</i>	<p>Le robinet de salle de bain monopiece à une poignée présente une configuration de fixation à trou unique de 4 po et comprend une cartouche en céramique, des conduites d'alimentation en cuivre de 1/4 po, un ensemble pour drain 50/50 et un aérateur standard de 1,5 gpm (5,7 L/min). Composants faits de laiton et de matériaux non métalliques au fini chrome poli standard.</p> 
Modifications	Conforme
<input type="checkbox"/> -0.5  <i>Aérateur de 0,5 gpm (1,9 L/min)</i> <input type="checkbox"/> -1.0  <i>Aérateur de 1,0 gpm (3,8 L/min)</i> <input type="checkbox"/> -G <i>Drain de la grille</i> <input type="checkbox"/> -Delete Suffix 1.5 <i>Aérateur de 2,2 gpm (8,3 L/min)</i> <input type="checkbox"/> -STN <i>Fini nickel satiné</i> <p>Remarque: Juxtaposer le -suffixe approprié au numéro demodèle.</p>	<p>-NSF/ANSI 372, NSF/ANSI 61.9 -ASME A112.18.1/CSA B125.1 -WaterSense 1.5 gpm (5.7 L/min)</p>   <p>Garantie</p> <p>À vie limitée -à l'acheteur original dans les installations du consommateur ou résidentielles. 5 ans - pour des installations commerciales et industrielles. Se reporter au site www.symmons.com/warranty (en anglais) pour l'information complète concernant la garantie.</p>

Dimensions

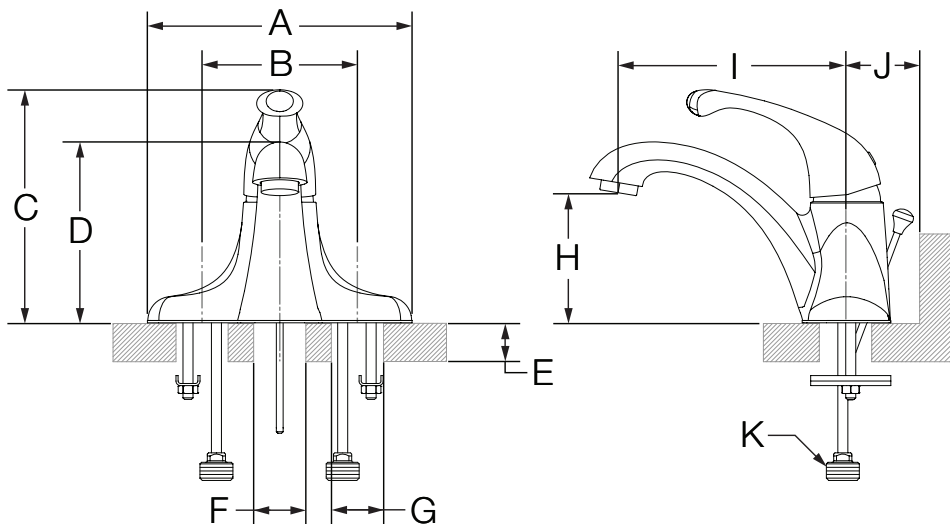

Mesures	
A	6 5/8 po, 168 mm
B	3 3/8 po, 86 mm
C	5 7/8 po, 149 mm
D	4 1/2 po, 114 mm
E	Épaisseur du comptoir Max. 1 3/8 po, 35 mm
F	Taille du trou Ø 1 3/8 po, 35 mm
G	(2x) Taille du trou Ø 1 1/2 po, 38 mm
H	3 1/4 po, 83 mm
I	5 3/4 po, 146 mm
J	Min. 2 1/2 po, 64 mm
K	1/2-14 NPSM

Remarque: Les dimensions sont sujettes à changer sans préavis.

Pièces de remplacement

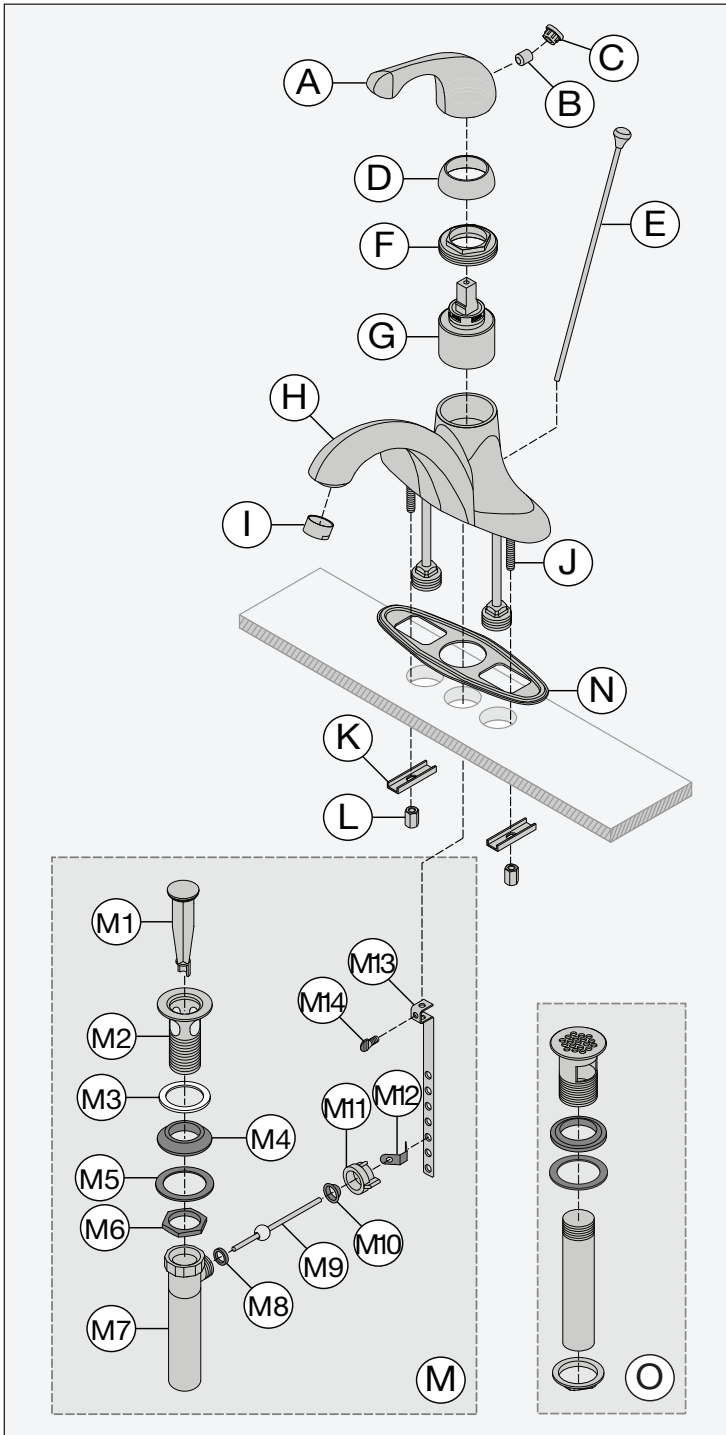





Pièces de remplacement

Article	Description	Numéro de pièce
A B C	Ensemble de poignée	RL-212*
E	Tige de levage	RL-213*
G	Cartouche	KN-4
K L N	Matériel de fixation	RL-214
I	Aérateur	RL-015-2.2 (2.2) RL-015-1.5 (1.5) RL-015-1.0 (1.0) RL-015-0.5 (0.5)
M	Ensemble pour drain 50/50	RL-223* (S-6612-1.5)
O	Drain de la grille	P-26* (S-6610-1.5)

***Remarque:** Juxtaposer le -STN au numéro de pièce pour le fini nickel satiné.

Outils requis

Clef ajustable	
Clef Allen (3/32 po)	
Mastic de plombier	
Ruban de plombier	

Installation



Si vous remplacez un vieux robinet, assurez-vous que l'approvisionnement en eau soit ÉTEINT (OFF) avant de l'enlever, tournez ensuite la vanne de contrôle du robinet à ON pour alléger la pression de l'eau.

- 1) Insérer le corps du robinet (H) et les tiges filetées (J) par le biais du joint de fixation (N) et les dolines.

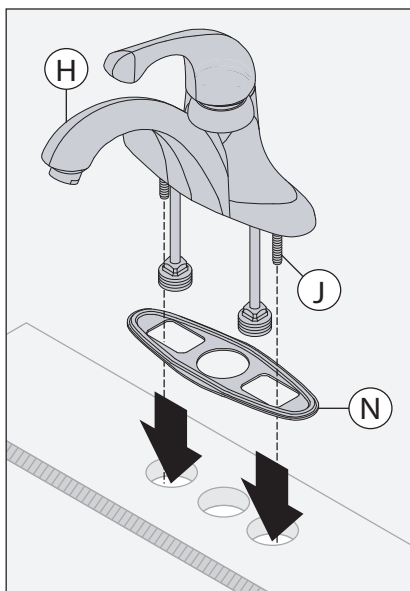

- 2) Placez les supports (K) sur les tiges filetées (J) et fixer avec les écrous (L).

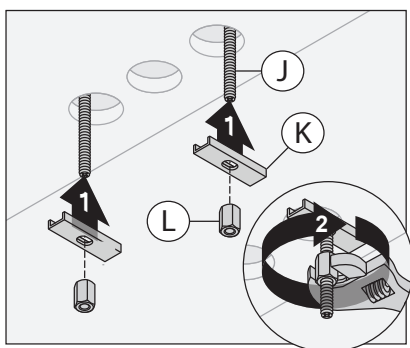

- 3) Bride à siège (M2) dans le vidoir (M3 joint en option). Installez le joint (M4), la rondelle (M5) et l'écrou (M6) sur la bride (M2) en dessous du vidoir, mais ne serrez pas l'écrou. Vissez la pièce de raccordement (M7) et serrez à la main.

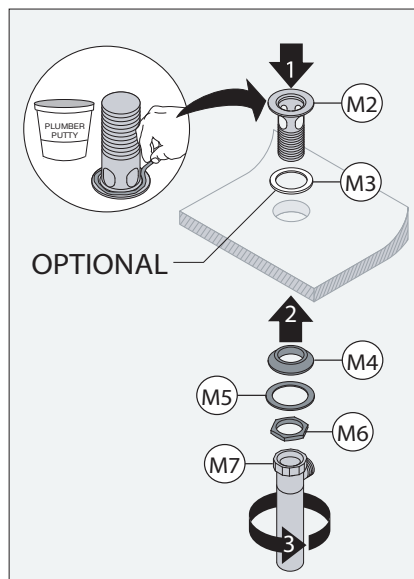

- 4) Tournez la pièce de raccordement (M7) et la bride (M2) afin que le pivot soit face au robinet. Tirez l'ensemble dans le trou de drainage. Fixez le matériel à l'ensemble en dessous du vidoir. Installez le bouchon (M1) dans la position amovible ou fixe.

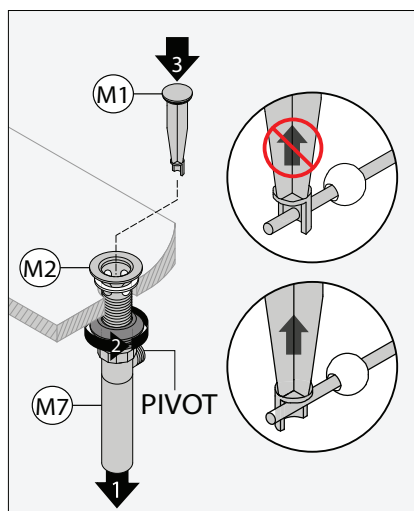

- 5) Attachez la tige de pivotement (M9) à la pièce de raccordement (M7). Serrez l'écrou (M11) à la main dans le sens des aiguilles d'une montre pour fixer la tige de pivotement (M9).

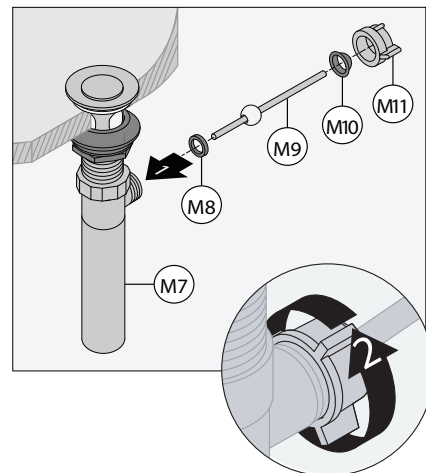

- 6) Connectez la tige de levage (E) à la sangle de manille (M13) et fixez avec la vis à tête (M14). Insérez la tige de pivotement (M9) dans la sangle de manille (M13). Fixez avec la pince à ressort (M12) et ajustez le couplage au besoin.

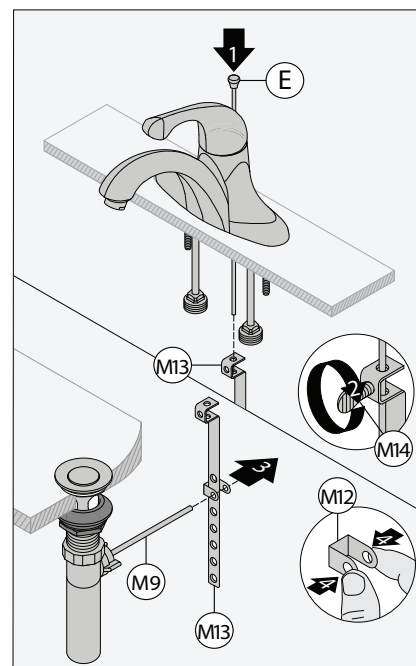

Installation

- 7) Fixer les conduites d'alimentation aux queues (H) de fixation du robinet et serrer à la main. A l'aide d'une clé, terminer avec un demi-tour. **NE PAS** trop visser.

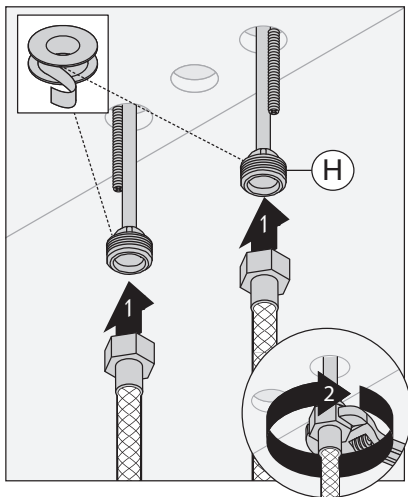

- 8) Appliquer du ruban de plombier pour la vanne d'entrée. A l'aide d'une clé, terminer avec un demi-tour. **NE PAS** trop visser.

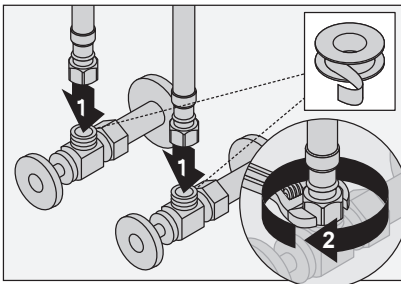

- 9) Enlevez l'aérateur (I) et rincez les conduites de tout débris. Vérifier pour déceler les fuites.

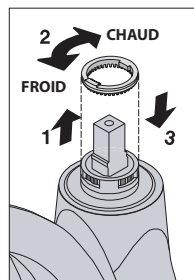
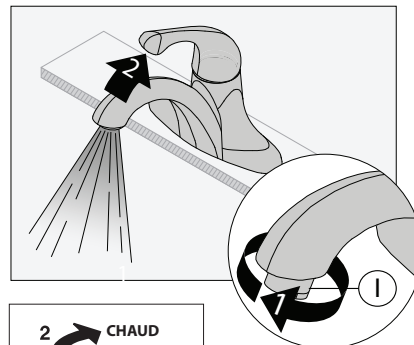

Remarque: Anti-horaire pour température inférieur, dans le sens horaire pour augmenter la température.

Coût d'entretien

- 1) Enlever bouchon (C) et la vis de réglage (B). Compteur - tourner dans le sens horaire, démonter la poignée (A), collet (D) d'écrou (F) et de cartouche (G).

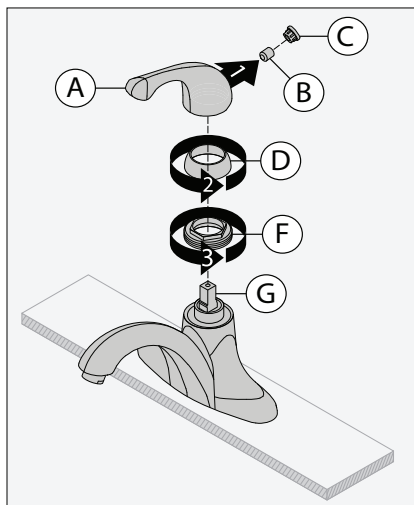

- 2) Retirez la cartouche (G) du corps de vanne (H). Inspectez pour voir s'il y a des débris. Remplacez la cartouche au besoin.

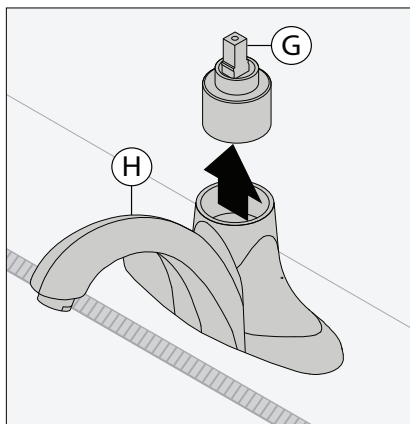

- 3) Correctement aligner cartouche (G) et les insérer dans le corps du robinet (H). Remplacer l'ensemble de poignée en suivant les instructions à l'étape 1, mais à l'envers.

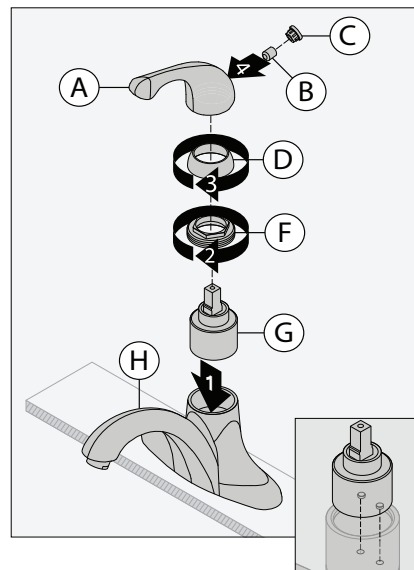

Tableau de résolution des problèmes

Le fini est tâché.

Les éléments dans l'alimentation en eau peuvent causer des taches sur le fini.

Nettoyez la boiserie avec un chiffon doux en utilisant un savon doux et de l'eau ou un nettoyant non abrasif et rincez rapidement avec de l'eau.