



## Décor Oval Rack - DR1

Thank you for choosing Enclume!

Enclume racks are the ultimate quality, design, strength and function.

### **WARNING: READ ALL OF THE INSTRUCTIONS BEFORE ASSEMBLING AND USING YOUR RACK**

If you need help, please call 1-877-ENCLUME

#### **Enclume Design Products**

24 Colwell Street, Port Hadlock, WA 98339

Phone 360-385-6100 • Fax 360-385-6156

[www.enclume.com](http://www.enclume.com)

Enclosed you will find everything needed for the assembly and use of your storage rack. Two people make assembly and installation easier. The parts and hardware included are:

#### **Hardware included:**

- 2- Ceiling Screw Hooks
- 2 - "S" Hooks
- 2 - 6 inch pieces of chain
- Toggler Kit

#### **Components included:**

- 1- Oval Rack
- 1- Grid
- 4 - Grid Brackets
- 12 - Pot Hooks

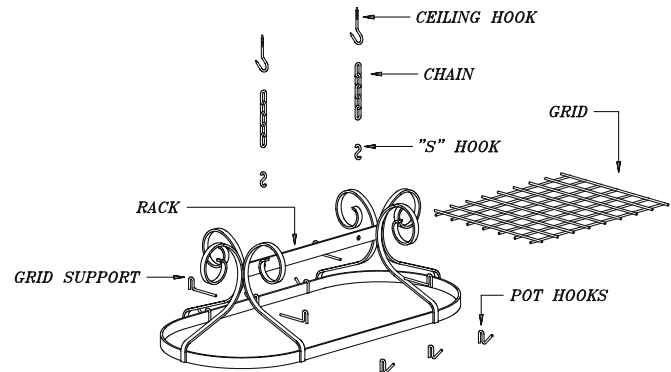

### **ASSEMBLY AND INSTALLATION INSTRUCTIONS**

- 1) We recommend that you anchor your rack into the solid wood of ceiling joists or beams. Carefully measure the area where the rack is to be hung and install the ceiling screw hooks directly into the wood joists. If it is not convenient to hang your rack directly into wood joists you may use the included DRYWALL anchors enclosed with your rack. See Toggler® brand manufacturer recommendations for weight limits included in the instructions in the Toggler kit.

#### **GRID ASSEMBLY**

- 2) Place the four grid brackets over the sides of the rack on the inside of each arm, with the straight end of the bracket facing to the inside of the rack. Next, rest the grid on top of the grid brackets.
- 3) Using both of the "S" hooks insert one end of each "S" hook through each of the holes at the top of the rack and the other end through one end of the chain. Place the other end of the chain over the ceiling screw hook.
- 4) Hang your heavier items on the straight portion of the rack body or from the center of the grid area.



It is important that your rack is assembled correctly. If the unit is assembled or used incorrectly, it could become unstable and collapse, possibly causing injury.

**Limited Warranty:** This product is warranted to be free of material defects for a period of five years from the date of purchase. Customer's exclusive remedy shall be the repair or replacement of the defective product and shall be subject to the following conditions: (1) notice of any defect is received by Enclume within the warranty period and (2) customer returns the defective product to Enclume Design Products, 24 Colwell St., Port Hadlock, WA 98339, *postage prepaid* within 20 days following a return authorization number (which may be obtained by telephoning the number at the top of this instructions) being provided to the customer by Enclume. There are no other warranties, expressed or implied. **THERE ARE NO WARRANTIES OF MERCHANTABILITY OR FITNESS FOR A PARTICULAR PURPOSE. ENCLUME SPECIFICALLY DISCLAIMS ANY AND ALL INCIDENTAL OR CONSEQUENTIAL DAMAGES ARISING OUT OF THE PURCHASE OR USE OF ENCLUME'S PRODUCTS.**