

SINCE 1839

**BRINLY**

SINCE 1839

**BRINLY**

# OWNER'S MANUAL

## **40" DETHATCHER**

MODEL:

**DT-402BH**

- Assembly
- Installation
- Operation
- Repair Parts

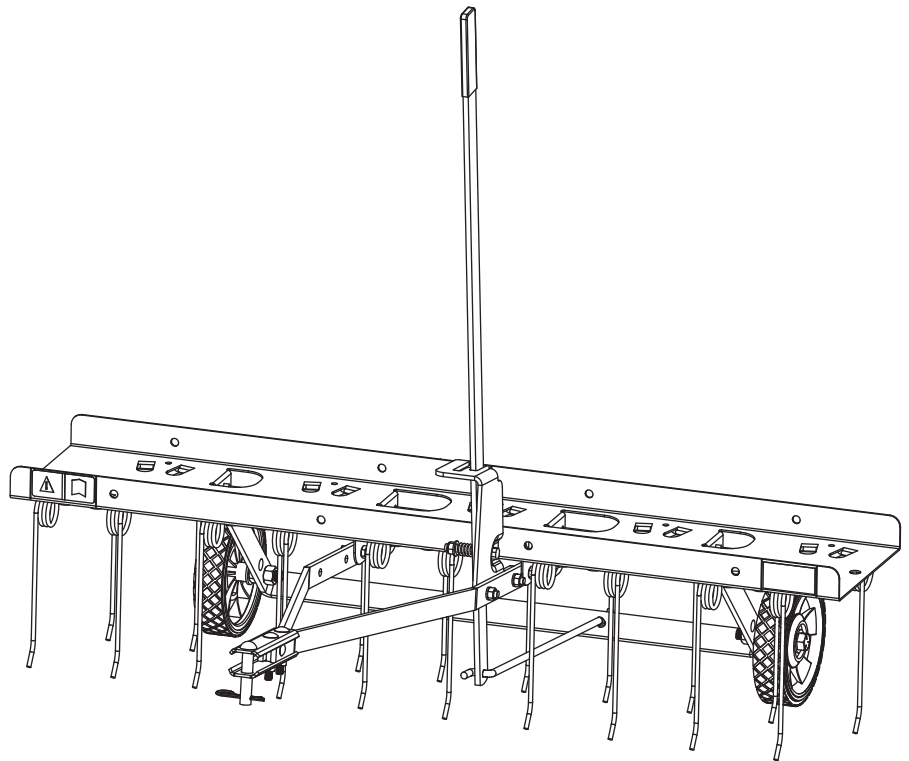

Original Instructions

For the latest product updates & setup tips:

Visit us on the web!  
[www.brinly.com](http://www.brinly.com)

Important: This manual contains information for the safety of persons and property. Read it carefully before assembly and operation of the equipment!

1008565EN-B

# INTRODUCTION AND SAFETY

CONGRATULATIONS on the purchase of your new Brinly-Hardy Dethatcher! Your Dethatcher has been designed, engineered and manufactured to give you the best possible dependability and performance.

Should you experience any problem you cannot easily remedy, please do not hesitate to contact our knowledgeable customer service department toll-free at 1-877-728-8224. We have competent, well trained technicians to help you with the assembly and use of your Dethatcher.

## CUSTOMER RESPONSIBILITIES

Please read and retain this manual. The instructions will enable to assemble and maintain your Dethatcher properly.

Please carefully read and observe the SAFETY section of this manual.

Follow a regular schedule in maintaining and caring-for your Brinly-Hardy Dethatcher.

## TABLE OF CONTENTS

SAFETY.....	2-3
COMPONENT VIEW AND REFERENCE LIST.....	4
ASSEMBLY.....	5-7
OPERATION.....	8
MAINTENANCE AND STORAGE.....	9
LIMITED WARRANTY.....	9

## SAFETY

### SAFETY LABELS AND NOTATION

 This symbol will help to point out important safety precautions throughout this manual. It means - ATTENTION! BECOME ALERT! your safety is involved.



The safety labels shown in this section are placed in important areas on your product to draw attention to potential safety hazards.

On your product safety labels, the words DANGER, WARNING and CAUTION are used with the safety-alert symbol. DANGER identifies the most serious hazards.

The operator's manual also explains any potential safety hazards whenever necessary in special safety messages that are identified with the word, CAUTION, and the safety-alert symbol.

### GENERAL NOTES (OPERATION)

Caution should be taken when towing and/or using any attachment. This attachment combined with the weight distribution, turning radius, and speed of towing vehicle can result in severe injury or death to operator, damage to towing vehicle, and/or attachment if not used properly. Follow all towing safety precautions noted in the towing vehicle owner's manual, including the following precautions:

- Ensure the combined weight of the towing vehicle (tow vehicle weight + operator weight) is greater than the maximum towed weight of attachment (empty attachment weight + weight of load).
- Do not exceed maximum towing capacity of towing vehicle.
- Do not exceed the maximum drawbar pull rating of the towing vehicle. Drawbar pull is the horizontal force required to pull the attachment (including weight of load).
- Only tow this product in the vehicle's tow mode/speed setting or less than 5 mph. Do not exceed 5 mph.
- Towing speed should always be slow enough to maintain control. Travel slowly and use caution when traveling over rough terrain. Avoid holes, rocks and roots.
- Slow down before you turn and do not turn sharply.
- Use wide turning angles to ensure the attachment follows the path of the towing vehicle.
- Do not use attachment on steep slopes. A heavy load could cause loss of control or overturn attachment and towing vehicle. Additional weights may need to be added to your vehicle; check with towing vehicle manufacturer for recommendations.
- Reduce towed weight when operating on slopes.
- Keep all movement on slopes slow and gradual. Do not make sudden changes in speed, directions, or turning.
- If you start and stop suddenly on hills, you may lose steering control or the towing vehicle may tip. Do not start or stop suddenly when going uphill or downhill. Avoid uphill starts.
- Slow down and use extra care on hillsides. Turf conditions can affect vehicle stability. Use extreme caution while operating near drop-offs.
- Do not drive close to creeks, ditches and public highways.
- Watch out for traffic when crossing near roadways.
- Use care when loading or unloading the vehicle into a trailer or truck.
- The attachment can obstruct the view to the rear. Use extra care when operating in reverse.
- When reversing, carefully back-up straight to avoid jackknifing. Do not allow towing vehicle wheels to contact attachment draw bar. Damage could result.
- Stop on level ground, disengage drives, set the parking brake, and shut off engine before leaving the operator's position for any reason including emptying the attachment.
- Use this attachment for intended purpose only.
- This attachment is intended for use in lawn care and home applications. Do not tow behind a vehicle on a highway or in any high speed applications. Do not tow at speeds higher than the maximum recommended towing speed.

- Do not tow this product behind a motor vehicle such as a car or truck.
- Always wear substantial footwear. Do not wear loose fitting clothing that can get caught in moving parts.
- Keep your eyes and mind on your towing vehicle, attachment and area being covered. Do not let other interests distract you.
- Stay alert for holes and other hidden hazards in the terrain
- Keep the towing vehicle and attachment in good operating condition and keep safety devices in place.
- The towing vehicle and attachment should be stopped and inspected for damage after striking a foreign object. Any damage should be repaired before restarting and operating the equipment.
- Keep all parts in good condition and properly installed. Fix damaged parts immediately. Replace worn or broken parts. Replace all worn or damaged safety and instruction decals. Keep all nuts, bolts and screws tight.
- Do not modify the attachment or safety devices. Unauthorized modifications to the towing vehicle or attachment may impair its function, safety and void the warranty.

#### TOWING VEHICLE AND TOWING SAFELY

- Know your towing vehicle controls and how to stop safely. READ YOUR TOWING VEHICLE OWNER'S MANUAL before operating.
- Check the towing vehicle brake action before you operate. Adjust or service brakes as necessary.
- Stopping distance increases with speed and weight of towed load. Travel slowly and allow extra time and distance to stop.
- Use only approved hitches. Tow this attachment only with a towing vehicle that has a hitch designed for towing. Do not connect this attachment except at the approved hitch point.
- Follow the tow vehicle manufacture's recommendations for weight limits for towed equipment and towing on slopes. Use counterweights or wheel weights as described in the towing vehicle operator's manual.
- Do not shift to neutral and coast downhill.
- Do not allow children to operate the towing vehicle. Do not allow adults to operate the towing vehicle without proper instruction or without having read the owner's manual.

#### PROTECT THOSE AROUND YOU

- Before you operate any feature of this attachment or towing vehicle, observe your surroundings and look for bystanders.
- Keep children, bystanders and pets at a safe distance away while operating this or any attachment.
- Use care when reversing. Before you back up, look carefully behind for bystanders.

#### KEEP RIDERS OFF TOWED ATTACHMENT AND TOWING VEHICLE

- Do not carry passengers.
- Do not let anyone, especially children, ride in/on this attachment, the towing vehicle or hitch bracket. Riders are subject to injury such as being struck by foreign object and/or being thrown off during sudden starts, stops and turns. Riders may also obstruct the operator's view resulting in this attachment being operated in an unsafe manner.

# COMPONENT VIEW AND REFERENCE LIST

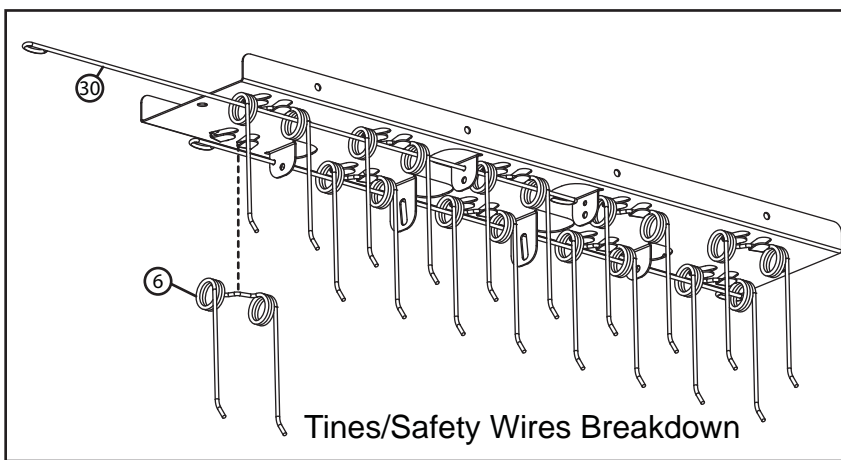

INSTALLATION  
QUESTIONS?  
MISSING PARTS?  
REPLACEMENT PARTS?

**DON'T GO BACK  
TO THE STORE!**

Please call our Customer Service  
Department Toll-Free at  
**877.728.8224**  
or  
www.customerservice  
@brinly.com

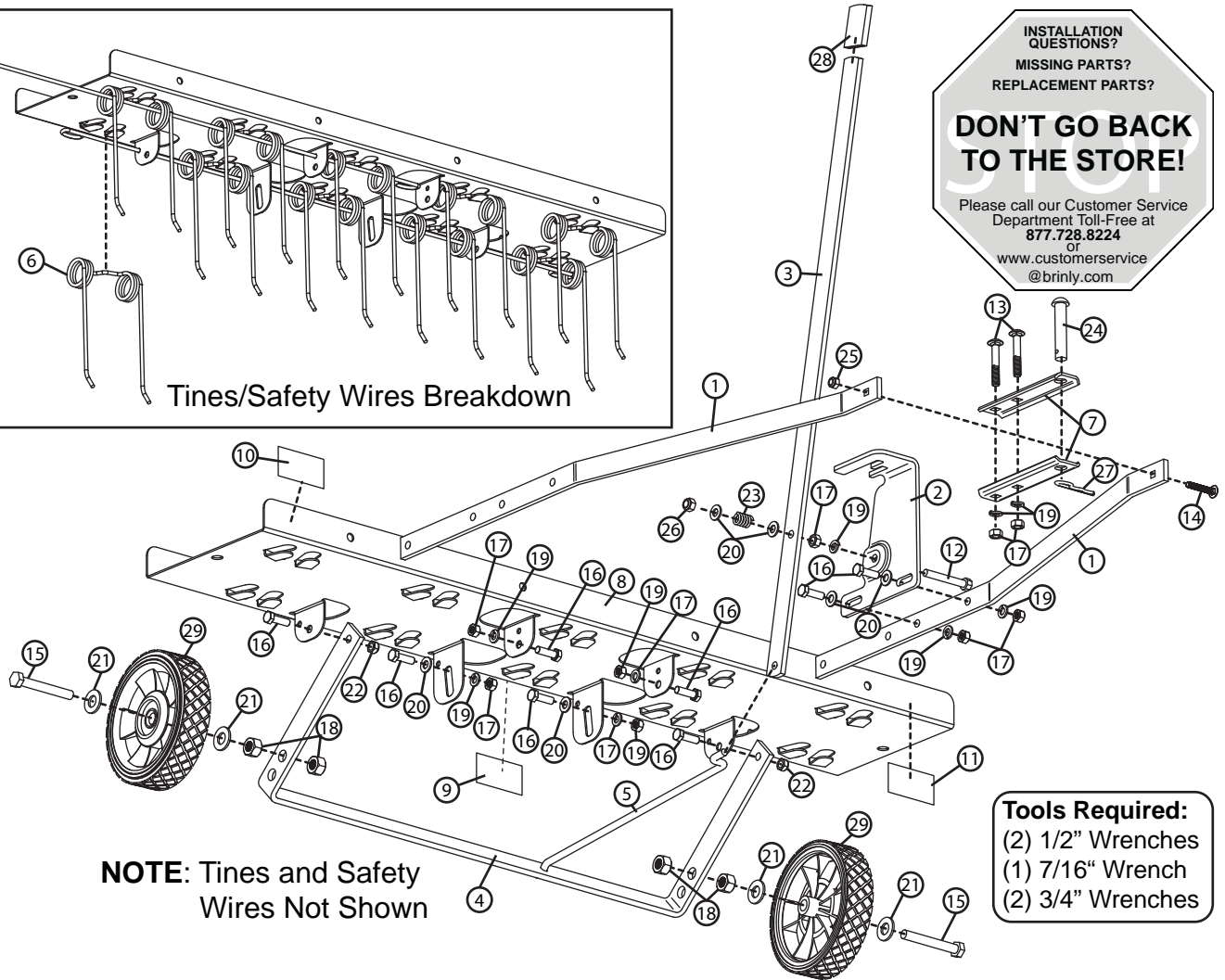

**NOTE:** Tines and Safety  
Wires Not Shown

**Tools Required:**  
(2) 1/2" Wrenches  
(1) 7/16" Wrench  
(2) 3/4" Wrenches

REF	PART NO.	DESCRIPTION	QTY	REF	PART NO.	DESCRIPTION	QTY
1	1008484-10	Towbar	2	16	2M1016P	Hex Hd. Bolt, 5/16" X 1"	8
2	1008486-10	Lift Lock	1	17	30M1000P	Nut, 5/16"	9
3	1008487-10	Handle	1	18	30M1600P	Nut, 1/2"	4
4	1008488-10	Wheel Bracket	1	19	40M1000P	Lock Washer, 5/16"	9
5	1008557	Control Rod	1	20	45M1111P	Flat Washer, 5/16"	6
6	R-616	Tine	10	21	45M1717P	Flat Washer, 1/2"	4
7	R-892-10	Clevis	2	22	B-1674P	Lock Nut, 5/16"	2
8	1008473-10	Tray	1	23	B-3805	Spring	1
9	1008563	BH Logo Decal	1	24	B-3861	Hitch Pin, 1/2" X 2-1/2"	1
10	B-7063	Caution Label	1	25	B-4785	Nylock Nut, 1/4"	1
11	L-1744	Serial No. Label	1	26	B-4786	Nylock Nut, 5/16"	1
12	1008605	Hex Hd. Bolt, 5/16" X 2-1/4"	1	27	D-146P	Hairpin Cotter, 1/8"	1
13	10M1032P	Carriage Bolt, 5/16" X 2"	2	28	R-1882	Vinyl Grip	1
14	11M0824P	Carriage Bolt, 1/4" X 1-1/2"	1	29	1008587	Wheel, 6" X 1.5"	2
15	1M1648P	Hex Hd. Bolt, 1/2" X 3"	2	30	R-1503	Safety Wire, 40"	2

# ASSEMBLY

This manual will be referencing panels of the hardware skinpack included with your dethatcher. The hardware in Panel 1A is to be used with assembly step 1A; Panel 1B with Assembly Step 1B; etc.

**CAUTION:** Avoid injury! Take care when handling Tray and Tine sub-assembly. Tine tips are sharp and can cause injury.

Carefully remove Tray and Tine sub-assembly from the carton and lay flat on working surface with tines pointing up.

- 1A) Using the hardware in panel 1A, assemble the two towbars (1) to the tray (8) as shown in Figure 1. Leave assembly hardware loose in this step so that tine height can be adjusted later.

**NOTE: It is important for the safety and function of the Dethatcher that the towbar, tray and hardware be assembled as shown in Figure 1.**

- 1B) Using the hardware in panel 1B, assemble the Clevis (7) to the Towbars as shown in Figure 1. Assemble all hardware hand tight. While holding the two 5/16" Carriage Bolts (13) in the square holes on the Clevis, tighten the 1/4" Carriage Bolt (14) and Nylock Nut (25). Tighten the 5/16" Nut (17) to the 5/16" Carriage Bolt (13). Assemble the Hitch Pin (24) to the Hairpin Cotter (27) through the Clevis.

- 1C) Turn the Dethatcher over so that it is resting on Tine Tips and front of Towbars.

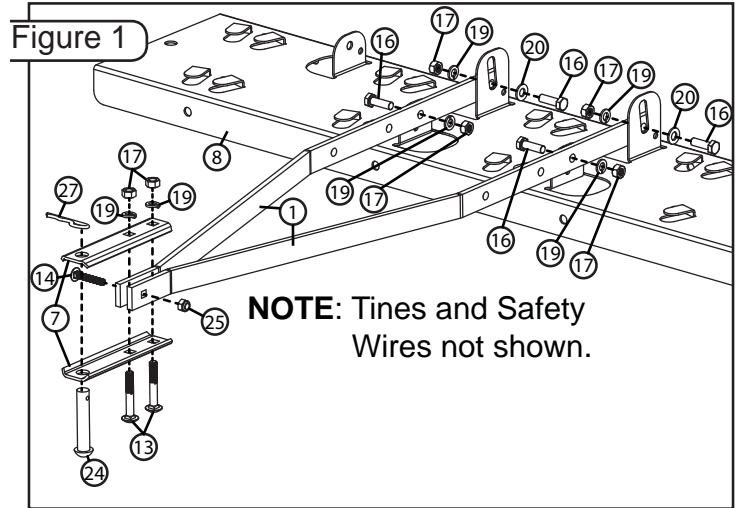

- 2A) Using the hardware in Panel 2A, attach the Lift Lock (2) to the Towbar (1) as shown in Figure 2. Leave assembly hardware loose for this step so that tine height can be adjusted later.

**NOTE: It is important for the safety and function of the Dethatcher that the towbar, tray and hardware be assembled as shown in Figure 1.**

- 2B) Assemble the hardware in Panel 2B through the Lift Lock as shown in Figure 2. Tighten securely.

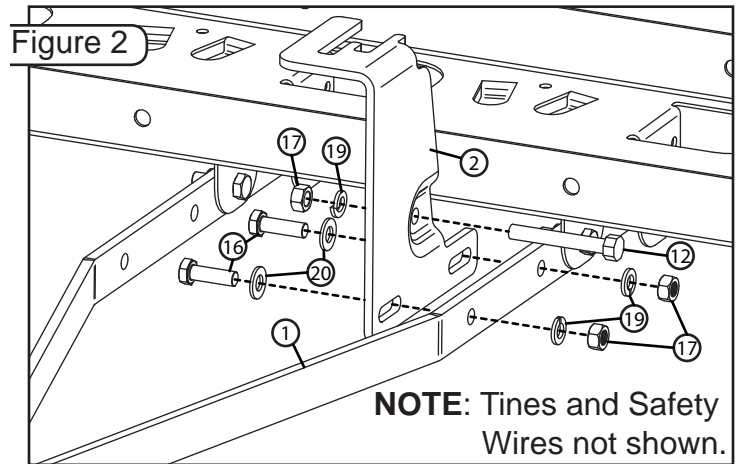

- 3A) Pre-Assemble the Wheels (29) using the hardware in Panel 3A as shown in Figure 3. Tighten the Nuts on the Wheels Completely.

**NOTE: Observe that the Nut (18) is assembled on the hub offset side of the wheel.**

- 3B) Attach the pre-assembled Wheels to the Wheel Bracket (4) using the hardware in Panel 3B.

**NOTE: Use common hole locations from left to right side of Wheel Bracket.**

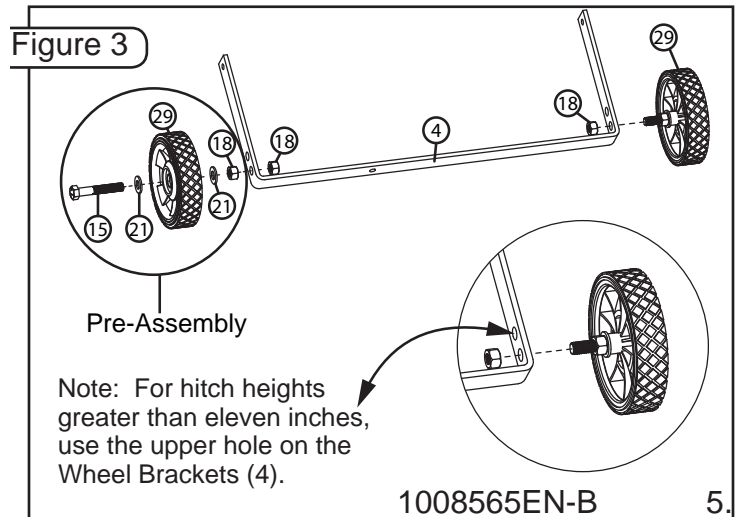

# ASSEMBLY

- 4) Attach the Wheel Bracket (4) to the Tray (8) using the hardware in Panel 4 as shown in Figure 4.

**NOTE:** Tighten the nuts assembled in this step to allow the Wheel Bracket Assembly to rotate with minimum "side to side" looseness.

Figure 4

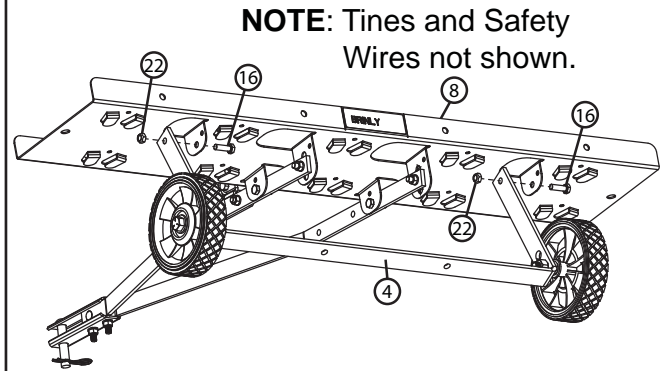

- 5) Starting with the 90 degree bent end, assemble the Control Rod (5) into the left hole on the Wheel Bracket (4) as shown in Figure 5. Feed Control Rod (5) through hole until opposite end engages with Wheel Bracket (4).

**NOTE:** The Control Rod Must Be orientated as shown in Figure 5 after assembly.

Figure 5

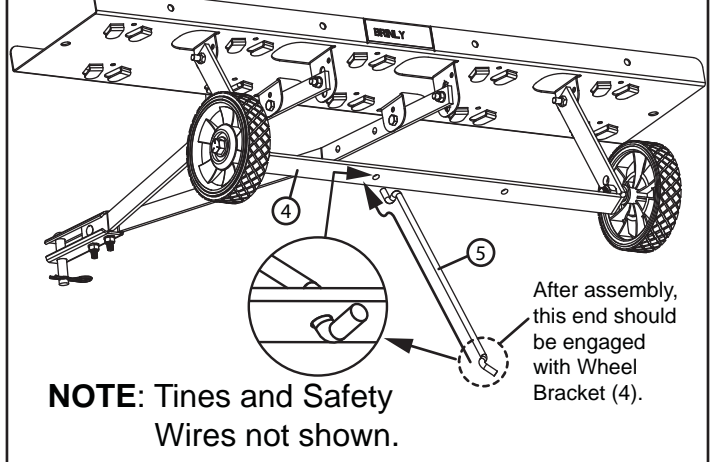

- 6A) Orientate Handle (3) between Towbars. Attach the end of the Control Rod with the 90 degree bends to the Handle (3) as shown in Figure 6.

- 6B) Assemble the handle onto the Bolt (12) that runs through the Lift Lock (2) as shown in Figure 6. Orientate Handle so that it is engaged with one of the Tine height settings on the Lift Lock (2). Figure 7 shows the handle in set to detatch mode.



**CAUTION:** Avoid Injury! Movement and Tine height adjustment of Handle, Lift Lock, and Spring can be a pinch point. Take care when working in this area.

Figure 6

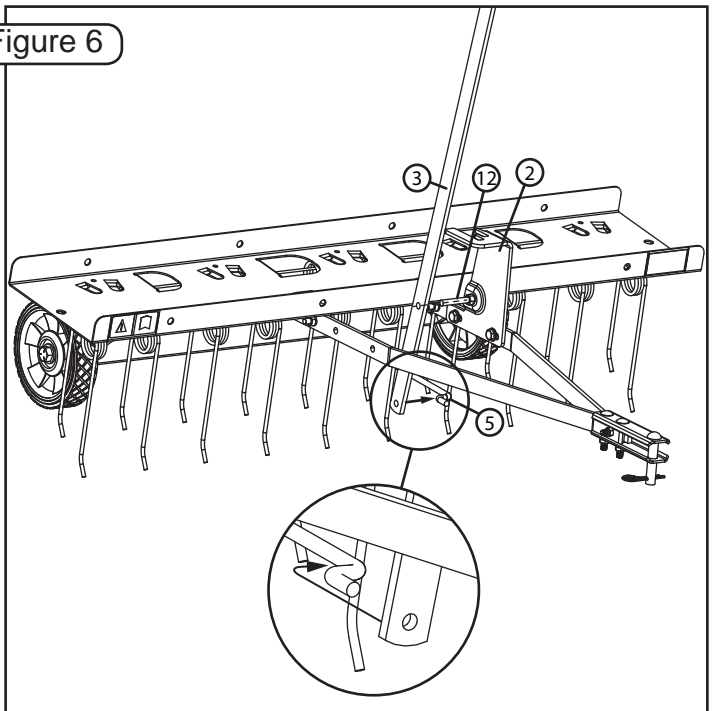

# ASSEMBLY

- 7) Fasten the Handle (3) in place using the hardware in Panel 5. Use Figure 7 as a guide.  
**NOTE: Do not over tighten 5/16" Nylock Nut (26). Do not fully compress Spring (23).**
- 8) Place Vinyl Grip (28) from Panel 6 on end of Handle (3) as shown in Figure 7.

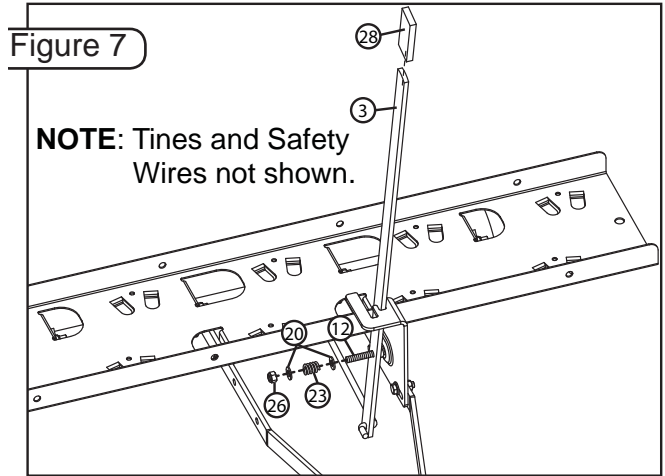

**NOTE:** Tines and Safety Wires not shown.



**CAUTION:** Avoid Injury! Dethatcher can become unstable as Towbar Angle is increased from ground. While manually moving your Dethatcher, keep Towbar level with the ground and hold Handle firmly against Lift Lock.

## OPERATION

### INSTALLING YOUR DETHATCHER



**CAUTION:** Avoid Injury! Make sure feet and hands are clear of Tine Tips.

- 1) Park towing vehicle safely and set parking brake. (See towing vehicle manual).
- 2) Align Dethatcher clevis (7) with towing machine hitch plate.
- 3) Install Hitch Pin (24) through Clevis and towing machine hitch plate. Secure Hitch Pin with Hairpin Cotter (27).

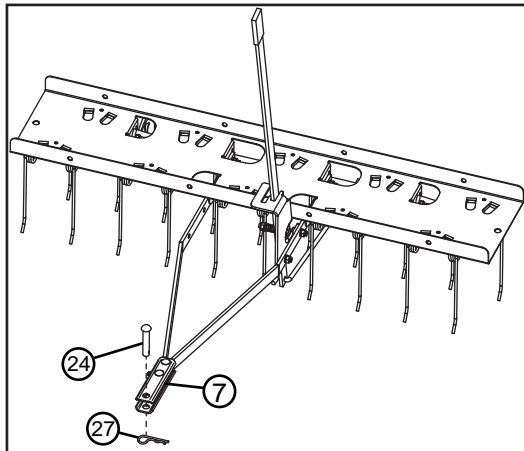

4. Park towing vehicle safely and set the parking brake (see towing vehicle operator's manual).
5. Place Dethatcher in Transport Setting.
6. Unload weight from Dethatcher tray.
7. Remove Hairpin Cotter (27) and Hitch Pin (24) from the Clevis (7).
8. While keeping Tow Bar level with the ground and holding the Handle in Transport Setting, push Dethatcher away from the towing vehicle.
9. Install Hitch Pin (24) and Hairpin Cotter (27) for storage.

### ADJUSTMENT OF TINE HEIGHT

This Dethatcher operates with hitch heights between 7 and 14 inches.



**CAUTION:** Avoid Injury! When changing Dethatcher Tine height settings from the towing vehicle seat: Park safely and set the parking brake (see towing vehicle operator's manual), shift to neutral and disengage Blade.

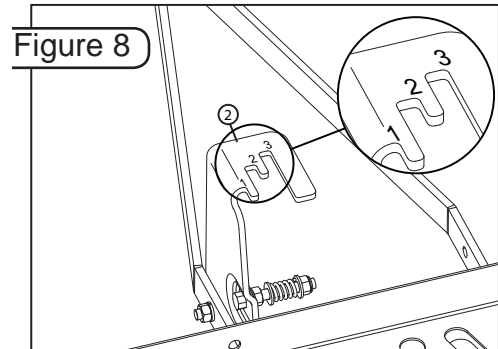

### REMOVING YOUR DETHATCHER



**CAUTION:** Avoid Injury! Keep body parts away from under drawbar. Do not attempt to disconnect Dethatcher from towing vehicle with weight on the tray.



**CAUTION:** Avoid Injury! Dethatcher can become unstable as Tow Bar angle is increased from ground. While moving your Dethatcher, keep Towbar Level with ground and hold Handle firmly against the Lift Lock.

The Dethatcher has three possible Tine height settings on the Lift Lock (2) as shown in Figure 8.  
 Transport Setting – Position 1: Raises the Tines so that the Dethatcher can be towed without the Tines touching the ground  
 Dethatch Setting – Position 2: Used for general dethatching  
 Scarify Setting – Position 3: Allows tines to drag along the ground to scarify a seed bed.



**CAUTION:** Avoid Injury! Make sure feet and hands are clear of Tine Tips. Never operate Dethatcher without safety wires properly installed.

# OPERATION

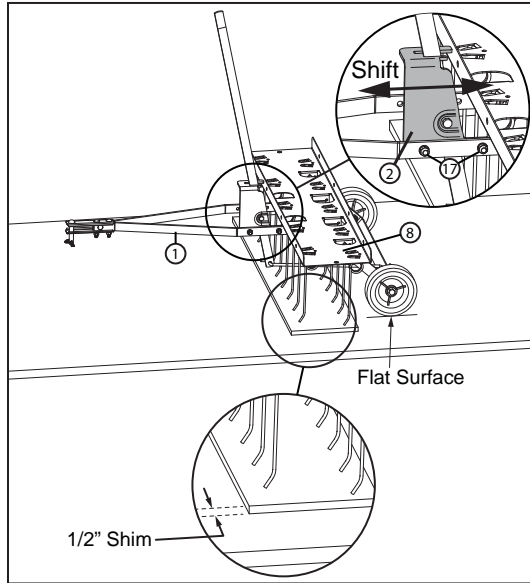

1. Select a smooth ground surface such as a driveway, sidewalk, garage floor, etc.
2. Park towing vehicle safely and set the parking brake (see towing vehicle operator's manual).
3. Install Dethatcher to towing vehicle hitch plate as previously described in the Installing Your Dethatcher section.
4. Put Handle in Dethatch Setting on Lift Lock (2) (center notch marked 2).
5. Place Tine tips on a 1/2" shim. When both rows of Tines are touching the shim, tighten the four bolts that fasten the Tow Bars (1) to the Tray (8).

**NOTE: Your product packaging can be used as the 1/2" shim. Two thicknesses of cardboard equals approximately 1/2". Take care not to puncture the cardboard with the Tine tips while making your adjustments.**

6. Shift the Lift Lock (2) along its slots to make sure the wheels rest firmly on the ground surface. Ensure that the tines remain on the 1/2" shim and that the Handle remains in the Dethatch Setting. Tighten the two bolts (17) that fasten the Lift Lock (2) to the Tow Bar (1).
7. Remove 1/2" shim and check Tine adjustment. Push Tines tips rearward. Tine tips should barely touch ground surface. If not, repeat the adjustment.

**NOTE: If weight is used in Tray, recheck Tine height adjustment as stated in Step 8. Repeat Tine height adjustment as necessary with added weight.**

## USAGE



**CAUTION: Avoid Injury! Avoid damage to tines. Use Transport Setting when towing the Dethatcher across concrete or asphalt driveways and walkways.**

Safety Glasses should be worn when using the Dethatcher.

Excessive towed load can cause loss of control on slopes. Stopping distance increases with speed and weight of towed load.

Total towed weight must not exceed combined weight of towing vehicle, ballast and operator.

## DETHATCHER WEIGHT

The following maximum loaded weight capacity is the weight of the Dethatcher plus the maximum weight loaded into the Dethatcher Tray:

Model	Weight
DT-402BH	35 lbs. (empty)
Maximum Tray Weight	70 lbs
Maximum Towed Weight	105 lbs

## GRASS HEIGHT AND TINE ACTION

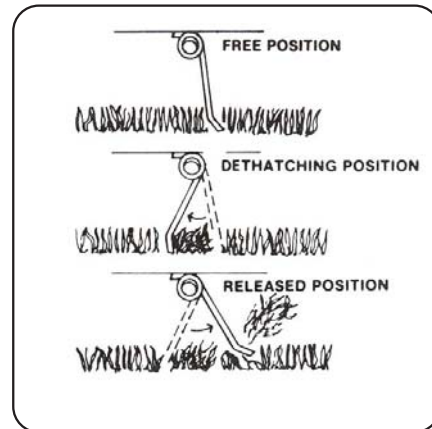

Grass should be less than 3" tall for proper Tine action in Dethatch Setting.

When in use, Tines on the Dethatcher should deflect back and 'flip' the thatch forward as shown.

If the Tines seem to drag without flipping forward, the Tray is too low and should be raised.

If the Tines stay in the free position, the tray is too high and should be lowered.

Make adjustments as necessary, up or down, by no more than 1/4" each time, until proper results are achieved. Similar adjustments may be possible by shifting the Lift Lock forward or rearward.

In normal operating conditions, adding weight to the Tray for dethatching and scarifying operations should not be necessary.

If the Dethatcher appears to be 'jumping' or 'walking' during operation:

1. Confirm the Handle is in the desired setting
2. Confirm Tine height is adjusted properly.
3. Add weight to the tray as needed (70 lbs maximum).

**NOTE: Weight should be added to the tray only when Dethatcher is attached to the towing vehicle.**

Weight should be secured by rope, straps, or other suitable means to contain the weight in the tray.

Confirm Tine height is adjusted properly after weight is added.

Maximum capacity of the Dethatcher Tray is 70 lbs.

## SPEED

The best operating speed is 3 mph or less.

Maximum operating speed is 5 mph.

## FREQUENCY

You can dethatch your lawn in summer, fall and when the lawn is dormant in winter. Dethatching is not recommended during the start of active growth.

An appropriate time to dethatch a cool-season lawn is early fall or early spring. An appropriate time to dethatch a warm-season lawn is early summer.

A moderate to dry lawn condition is recommended when dethatching.

It may take several passes to entirely dethatch your lawn. Make each pass in the same direction to avoid damage to grass roots.

The process of dethatching can leave your lawn unsightly. Be patient. With proper fertilization and watering, your lawn will grow strong and full.

The Dethatcher may be used in an independent operation or may be used when mowing your lawn.



# STORAGE, MAINTENANCE, AND LIMITED WARRANTY

## ***MAINTENANCE AND STORAGE***

### **MAINTENANCE**

The key to years of trouble-free service is to keep your Dethatcher clean and dry.

After the first 30 minutes of use, check all fasteners for tightness. Thereafter, periodically check all fasteners for tightness.



**CAUTION:** Avoid Injury! Do not operate Dethatcher without Safety Wires installed. Failure to keep Safety Wires installed can result in personal injury if a Tine should disengage from the Dethatcher Tray.

Tines are manufactured and tested for high quality and durability. However, should a Tine need replacement, contact the Brinly-Hardy customer service department to purchase replacement Tines and Safety Wires. Tines can be serviced as follows:

1. Straighten bend at the end of the Safety Wire and remove from Tine row.
2. Using a screwdriver or similar tool, pry the tabs open that are holding the Tine in need of service. Tabs can also be opened by tapping them down from the top of the Dethatcher Tray.
3. Remove Tine and replace with new Tine.
4. While holding the new Tine in position, bend the tabs back into the closed position.
5. Reinstall the Safety Wire.

Ensure to thread the Safety Wire through each Tine loop and holes in Tray tabs. Re-Bend end of the Safety Wire to hold Tine row. Ensure both bent ends of the Safety Wire are bent around the outer most Tine loop.

Apply a light coat of oil on tines after use to prevent rust.

For rust appearing on painted surfaces, sand lightly and paint affected area with enamel.

Periodically remove debris that builds up between Tines.

Check all moving parts for free movement and if necessary lubricate with oil.

### **STORAGE**



**CAUTION:** Avoid Injury! The Dethatcher Tines are sharp. Care should be taken when choosing a storage location for this product.

Store Dethatcher in low traffic aisle ways.

Store Dethatcher with Tine points facing the wall or ground.

Store Dethatcher on the ground or low to the ground.

Do not store Dethatcher hanging from the wall, ceiling or with Tine points facing outward.

Drawbar is a trip hazard. Avoid leaving Drawbar in aisle ways and walking paths.

## **MANUFACTURER'S LIMITED WARRANTY FOR**



The limited warranty set forth below is given by Brinly-Hardy Company with respect to new merchandise purchased and used in the United States, its possessions and territories.

Brinly-Hardy Company warrants the products listed below against defects in material and workmanship, and will at its option, repair or replace, free of charge, any part found to be defective in materials or workmanship. This limited warranty shall only apply if this product has been assembled, operated, and maintained in accordance with the Operator's manual furnished with the product, and has not been subject to misuse, abuse, neglect, accident, improper maintenance, alteration, vandalism, theft, fire, water, or damage because of other peril or natural disaster.

Normal Wear Parts or components thereof are subject to separate terms as follows: All normal wear parts or component failures will be covered on the product for a period of 90 days.

Parts found to be defective within the warranty period will be replaced at our expense. Our obligation under this warranty is expressly limited to the replacement or repair, at our option, of parts found to be defective in material and workmanship.

**HOW TO OBTAIN SERVICE:** Warranty parts replacements are available, ONLY WITH PROOF OF PURCHASE, through our Pull Behind Accessories Customer Service Department. Call 877-728-8224.

This limited warranty does not provide coverage in the following cases:

- a) Routine maintenance items such as lubricants and filters.
- b) Normal deterioration of the exterior finish due to use or exposure.
- c) Transportation and/or labor charges.
- d) The warranty does not include rental use.

**No implied warranty, including any implied warranty of merchantability of fitness for a particular purpose, applies after the applicable period of express written warranty above as to the part as identified below. No other express warranty whether written or oral, except as mentioned above, given by any person or**

**entity, including a dealer or retailer, with respect to any product, shall bind Brinly-Hardy Co. During the period of the warranty, the exclusive remedy is repair or replacement of the product as set forth above.**

**The provisions as set forth in this warranty provide the sole and exclusive remedy arising from the sale. Brinly-Hardy Co. shall not be liable for incidental or consequential loss or damage including, without limitation, expenses incurred for substitute or replacement lawn care services or for rental expenses to temporarily replace a warranted product.**

Some states do not allow the exclusion or limitation of incidental or consequential damages, or limitations on how long an implied warranty lasts, so the above exclusions or limitations may not apply to you.

During the warranty period, the exclusive remedy is replacement of the part. In no event shall recovery of any kind be greater than the amount of the purchase price of the product sold. Alteration of safety features of the product shall void this warranty. You assume the risk and liability for loss, damage, or injury to you and your property and/or to others and their property arising out of the misuse or inability to use this product.

This limited warranty shall not extend to anyone other than the original purchaser or to the person for whom it was purchased as a gift.

**HOW STATE LAW RELATES TO THIS WARRANTY:** This limited warranty gives you specific legal rights, and you may also have other rights which vary from state to state.

**IMPORTANT:** The Warranty period stated below begins with the PROOF OF PURCHASE. Without the proof of purchase, the Warranty period begins from the date of manufacture determined by the serial number manufacturing date.

#### **WARRANTY PERIOD:**

The warranty period for the product shown in this manual is as follows: Steel Frame Parts: consumer - 2 Years, commercial - 90 days. Tires, Wheels and Tines are normal wear parts - 90 days.

Brinly-Hardy Company, 3230 Industrial Parkway, Jeffersonville, IN 47130 (877) 728-8224

# BLANK PAGE

---

---

**BLANK PAGE**

---

# BLANK PAGE

---

---