

INSTALLATION INSTRUCTIONS FOR P5040-XXX-L

For Wall Mount Fixture

WARNING! SHUT POWER OFF AT FUSE OR CIRCUIT BREAKER.

AVERTISSEMENT ! COUPER LE COURANT AU NIVEAU DES FUSIBLES OU DO DISJONCTEUR.

PREPARATION

1. Shut off power at the fuse box or circuit breaker box. If necessary remove the old fixture and mounting hardware.
2. Carefully unpack your new fixture and lay out all the parts on a clear area. Be careful not to lose any small parts necessary for installation.

MOUNTING THE FIXTURE (Fig. 1)

3. Secure mounting back plate (B) to junction box (A) using junction boxes screws (C) (Size: 8-32*1/2"L). The side of the mounting back plate marked "GND" must face out.

CONNECTING THE WIRES (Fig. 2)

4. At this point, connect the electrical wires as shown in Fig. 2, making sure that all wire connectors are secured. If your outlet has a ground wire (green or bare copper), connect the fixture's ground wire to it. Otherwise, connect the fixture ground wire directly to the back plate (B) using the green screw (E) provided. After wires are connected, tuck them carefully inside the junction box.
5. Align the fixture's back plate (G) over mounting back plate (B) and secure with screws (H).

FINISHING THE INSTALLATION (Fig.1)

6. Slide the glass shade (J) into the front bracket (K) and secure the shield (L) to the front bracket with screws (M).

CAUTION /ATTENTION : When handling the fixture, do not apply pressure to the LEDs. Hold the fixture by the base or front bracket (K) only.

Replacing LED module (Fig. 3)

The LED module can be replaced by a qualified electrician without cutting of wire and without damage to any decorative element to which the fixture is attached. See installation steps for more details (Fig 3.).

- a. Remove screws (M) shield (L) and glass shade (J).
- b. Remove the wire nuts located inside the fixture backplate to disconnect the LED module.
- c. Remove screws (N) and the washers on bracket (K). Then release the wires (S) from quick connector (R) on LED module by using a pin to press the little hole located on the connector. Carefully remove the LED module (I) from bracket (K)
- d. Reverse steps a-c for installing the new LED module.
- e. Note: The LED module should be provided by a specified supplier.
- f. For better heat dissipation the LED module (I) should be applied with thermal grease when re-lamping.

IMPORTANT: Fixture should be installed by a qualified electrician to ensure proper wiring and installation.
Dimmable with ELV and/or LED compatible wall dimmer switches.

Fig.1

Set # A-020-151105

- Mounting plate
- Ground screw
- Mounting screw*2pcs

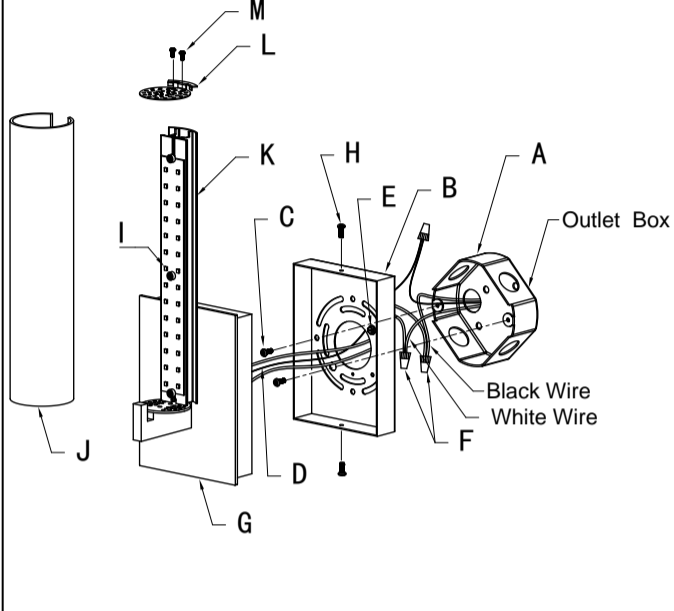

Fig.2

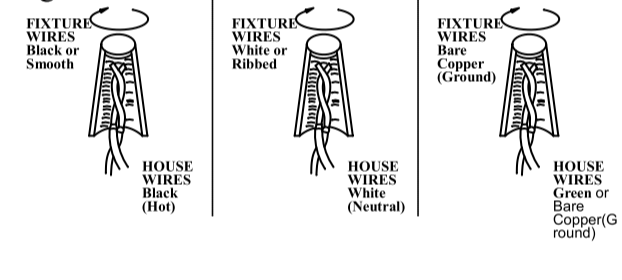
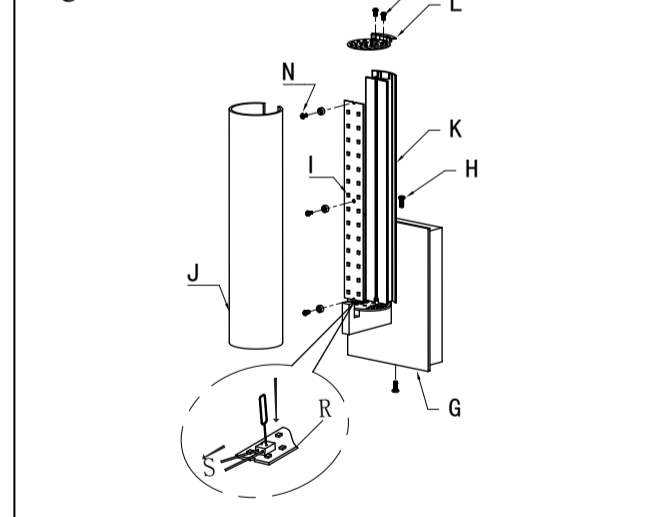

Fig 3



尺寸: 210X297mm (A4)

名称	说明书	产品	P5040-XXX-L
图号	SM10058	版本	3.0版
客户	MINKA	颜色	白底黑字
设计: (客户)	制图: 石贞祥	修改:	业务: 审核: