

HOME BAR SERIES

3 DRAWER BASE



Warning: Excessive weight hazard!

Use two or more people to move, assemble, or install cabinets and locker to avoid back injury. Do not leave children unattended near cabinets. High risk of tipping if cabinets are installed incorrectly: securely attach cabinets to the wall to avoid serious injury. For assistance, call 1.877.306.8930; for U.K 0800.031.4069; e-mail at info@newageproducts.com.

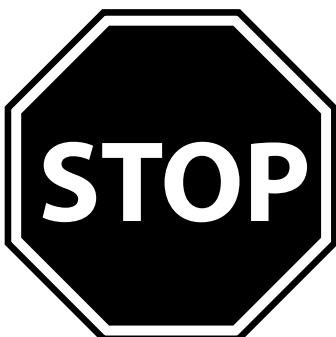

ATTENTION: Is your cabinet damaged? Need help or spare parts? For fastest service, contact NewAge Products at 1-877-306-8930; or support@newageproducts.com. Do not return to the retailer.

Weight Capacity

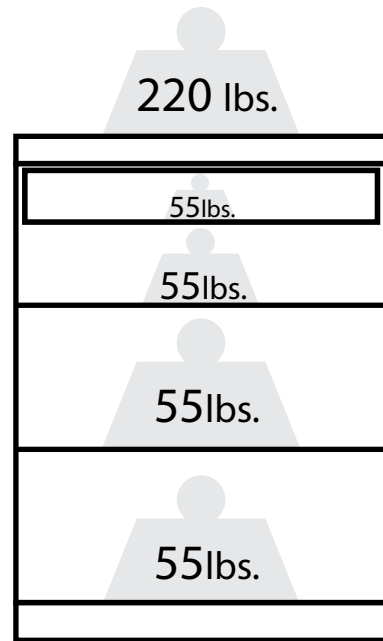

3 Drawer
Base Cabinet
Max 440 lbs.

Countertops

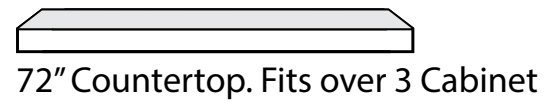
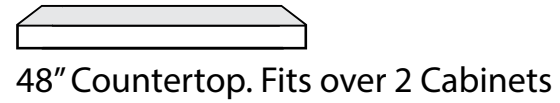

Unpacking

- Begin by placing the package on a covered flat surface.
- Remove all cardboard, foam packaging material and clear plastic bags.
- Dispose / recycle all packaging materials.
- Verify all the contents in the box and gather the required tools. See "Parts" and "Tools Needed" in the list below.

Parts Supplied

3 Drawer Cabinet

Handles	3
Handle Bolts (M4 x30mm)	6
#8 x 25mm Screws	6

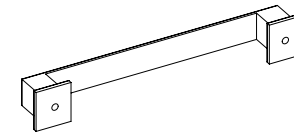

Handle



Handle Bolt
M4 x 30mm

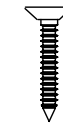

Screws
#8 x 25mm

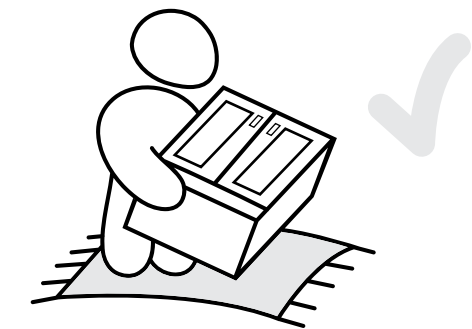
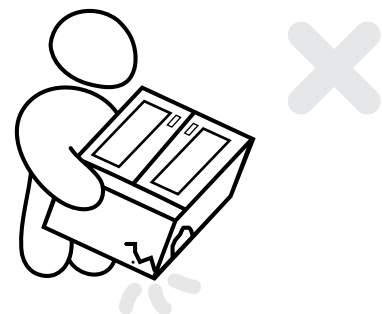
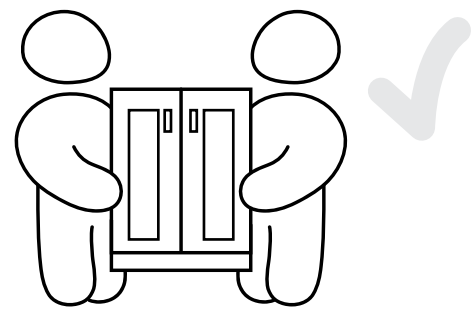
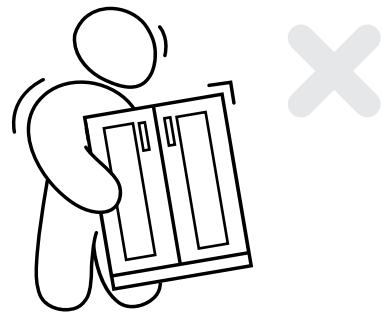

Tools Needed



1 x #2 Phillips head
screwdriver

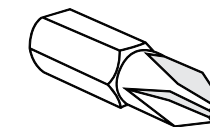

1 x #2 Phillips Bit
(optional)



1 x Cordless Power Drill
(optional)

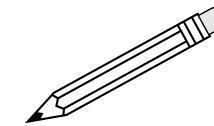

1 x Pencil

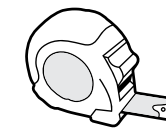

1 x Tape Measure



1 x Drill Bit
2.5mm or 3/32"

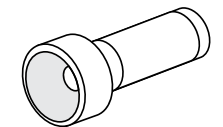

1 x Flashlight
(optional)

Installing the Handles

Note:
Cabinets come with handles installed on inside of drawers/doors.

1 Parts Needed.

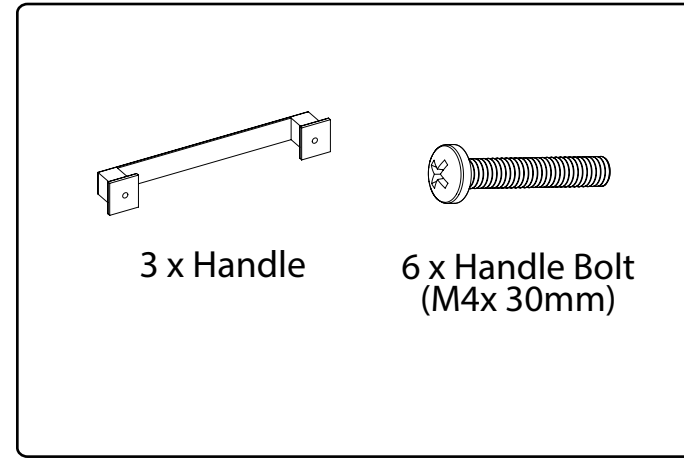

2 Align handle to holes on doors or drawers.

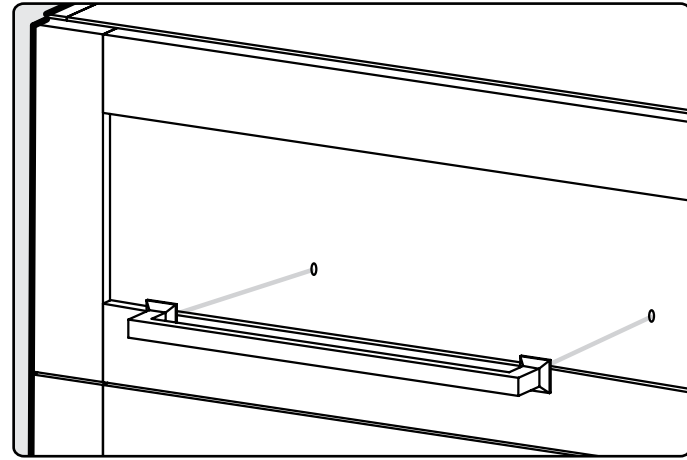

3 Screw in bolts.

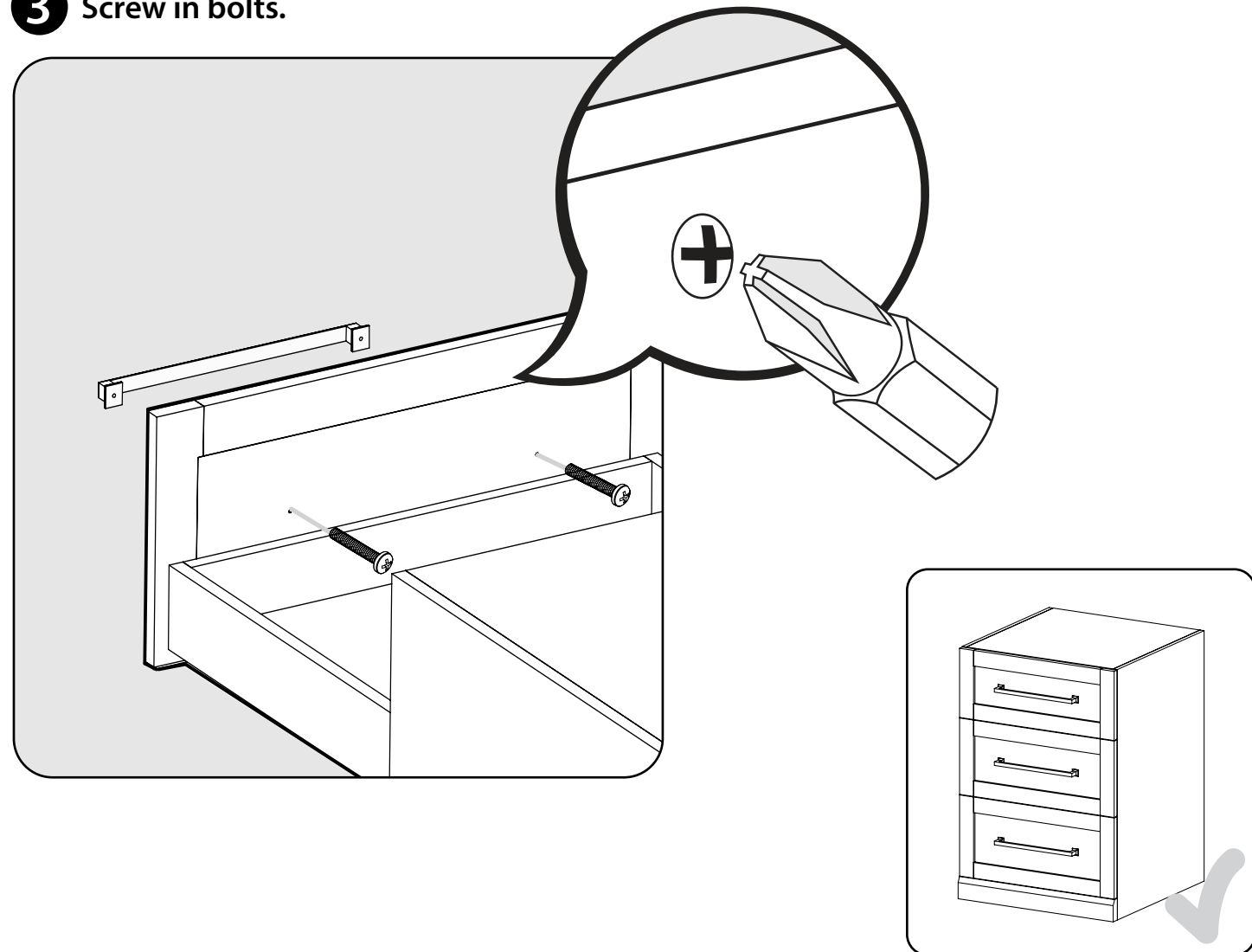

Removing Drawer

4 Extend drawer fully.

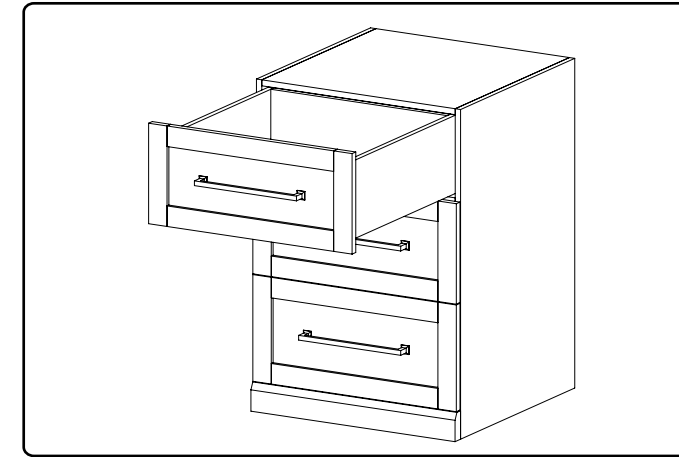

5 Press plastic triggers on underside of drawer according to arrows in image.

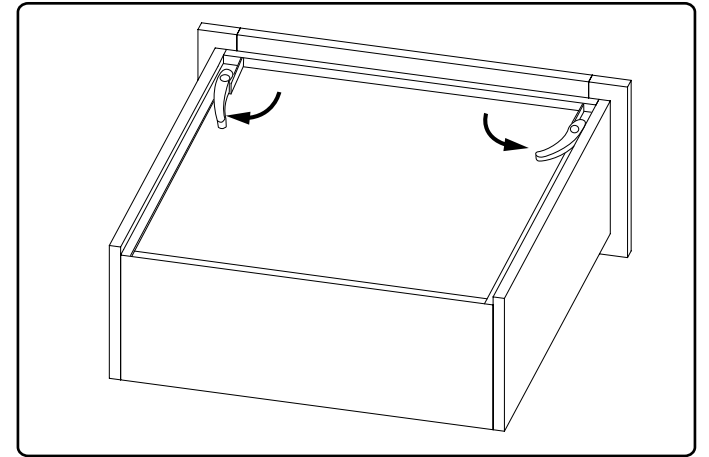

6 Tilt and remove shelf rack.

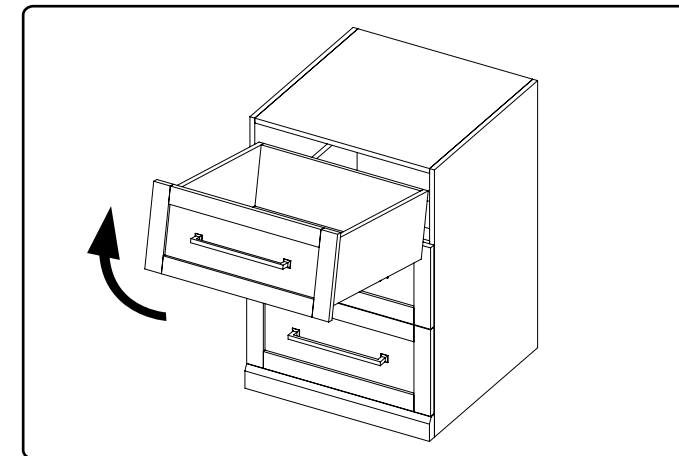

Inserting Drawer

10 Partially extend drawer slides.

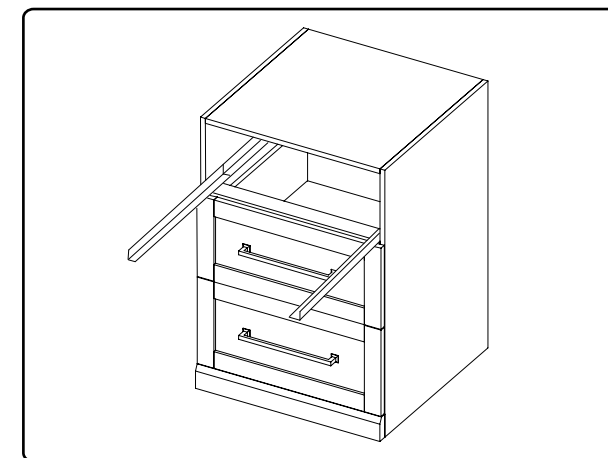

11 Put drawer on slides and slide each drawer slide forward until you hear a click sound.

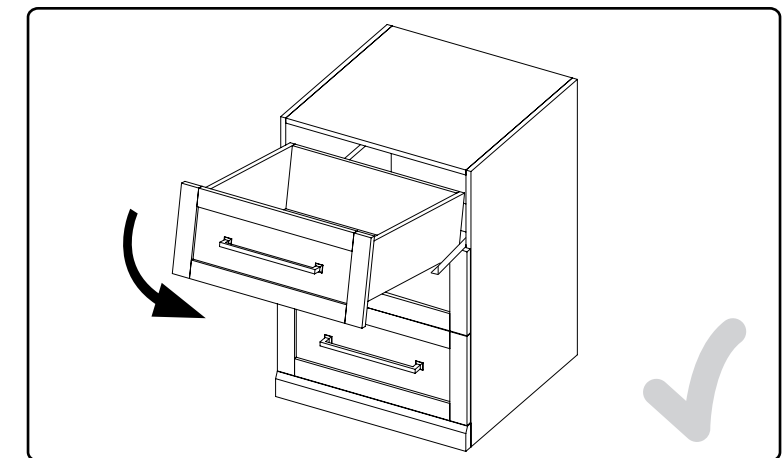

Fastening Cabinets

Note:
All drawers must be removed prior to fastening cabinets together.

9 Parts Needed.

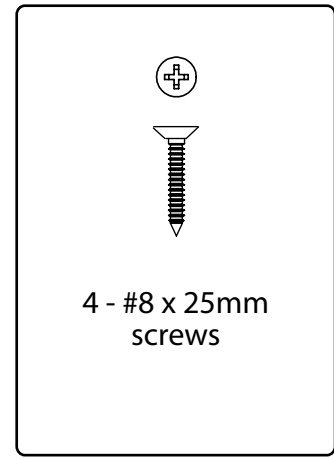

10 Drill 3/32" pilot holes on interior wall of cabinet being fastened.

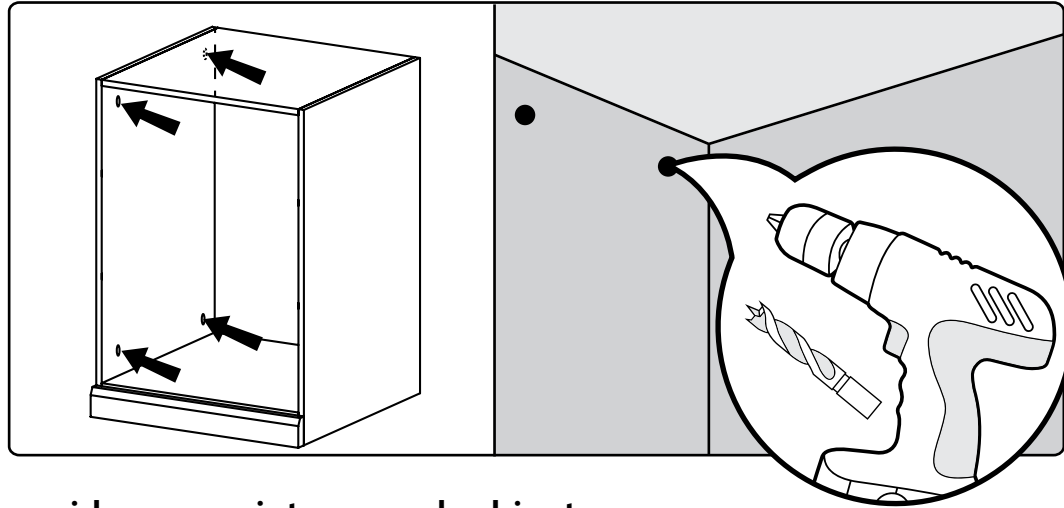

11 Using pilot hole as guides, screw into second cabinet. Do not over-tighten screws and punch through other side!

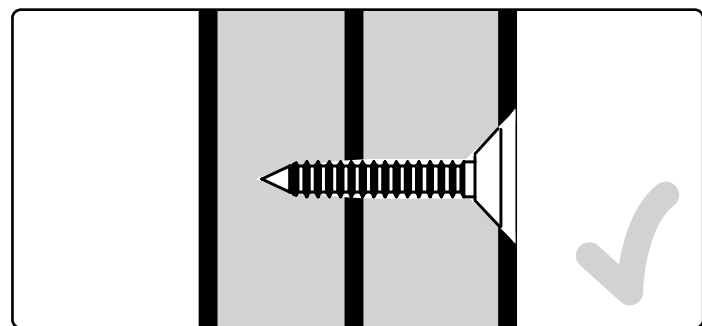
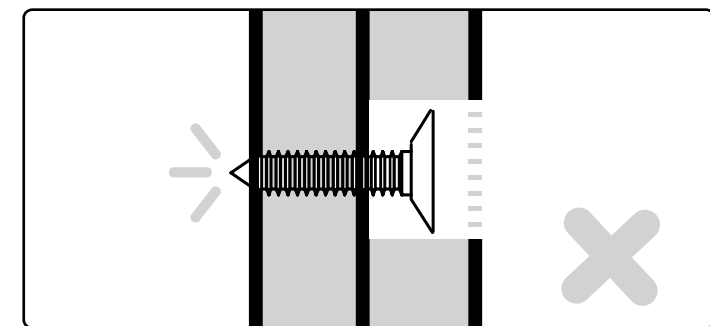
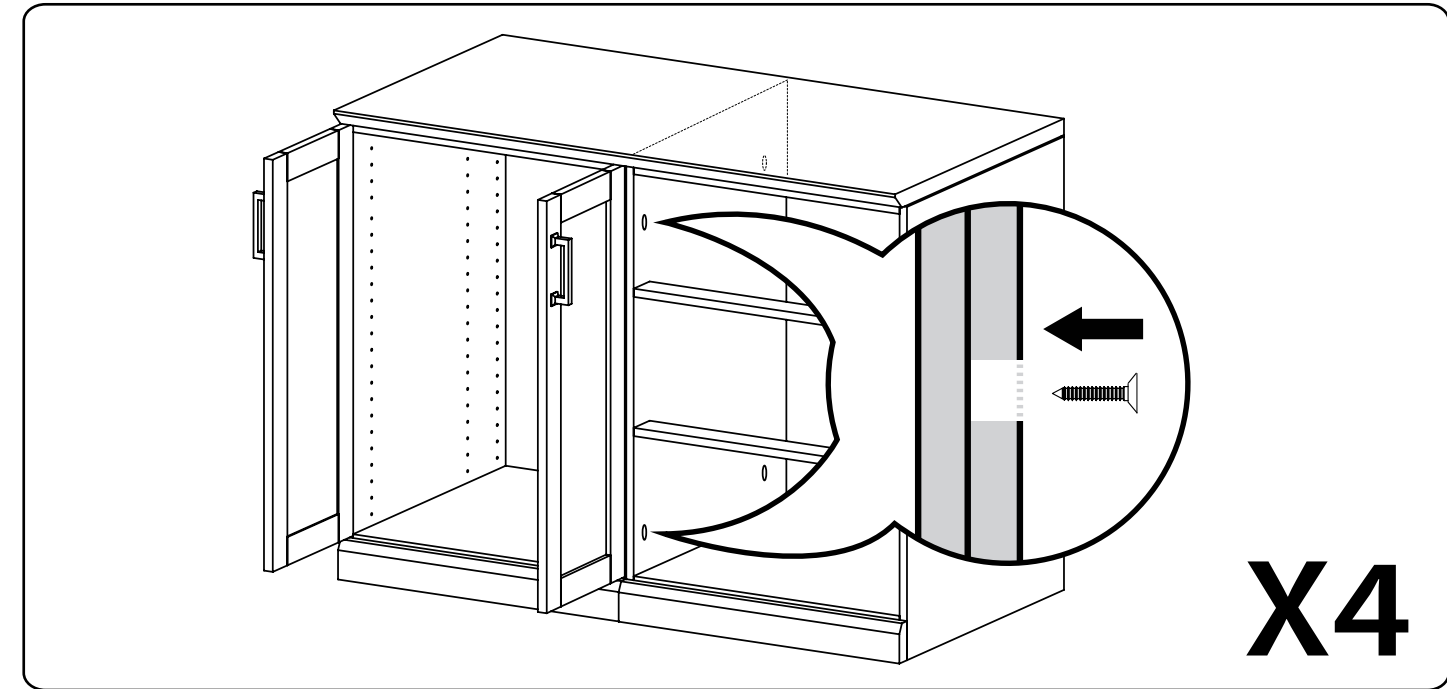

Mounting the Worktop

12 Parts Needed.

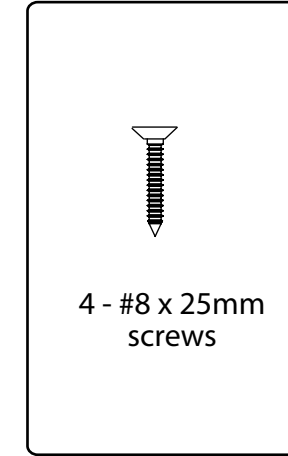

13 Place worktop over cabinets and lower onto cabinets.

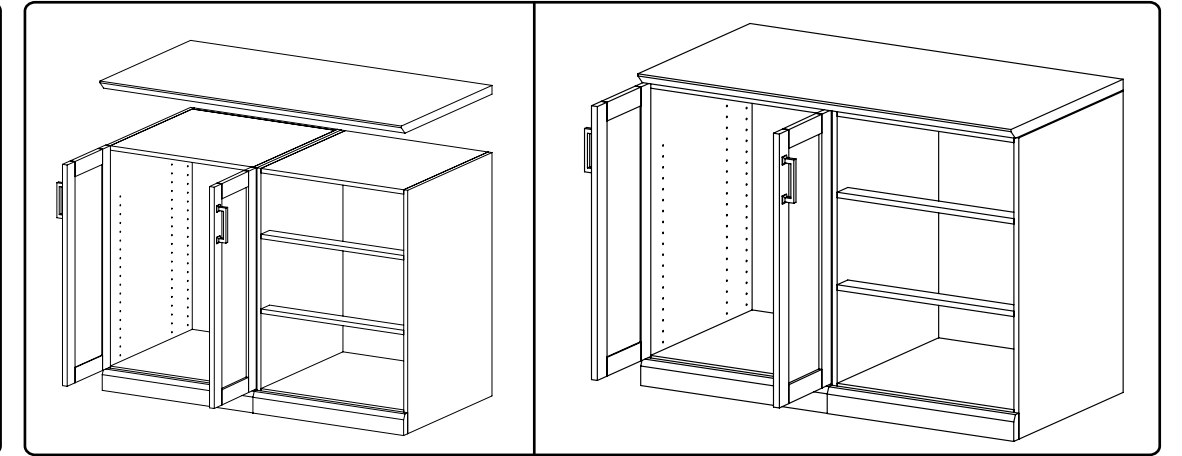

14 Drill 3/32" pilot holes on interior roof of cabinet.

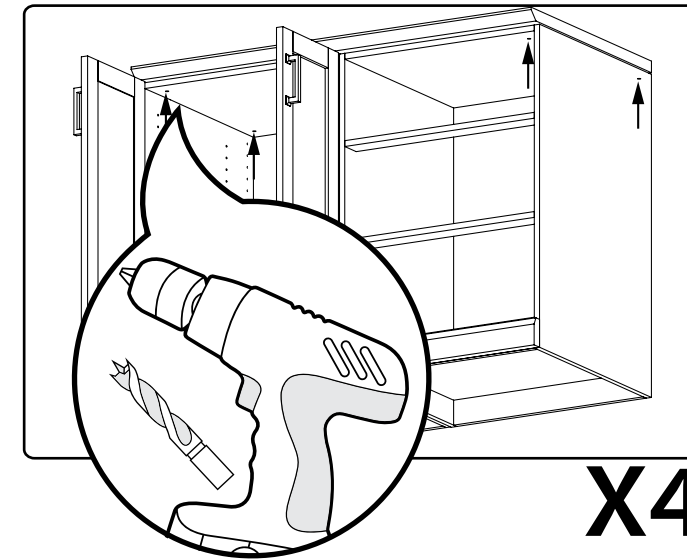

15 Tighten screws to secure cabinets.

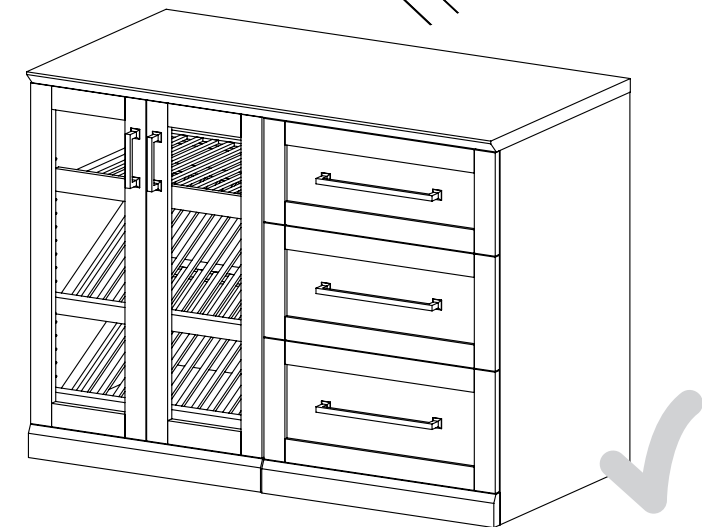
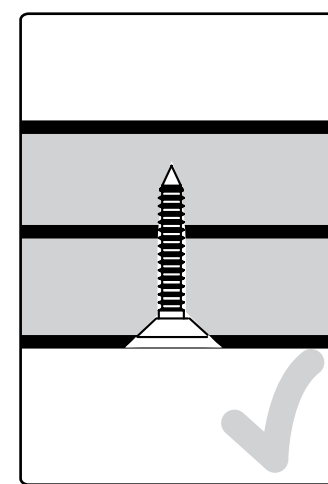
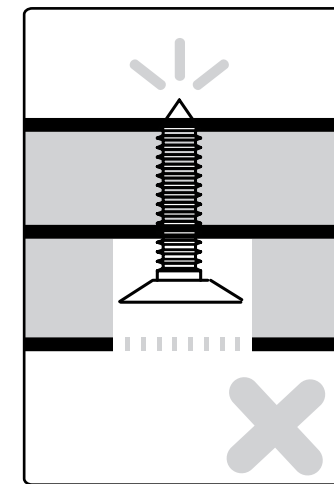
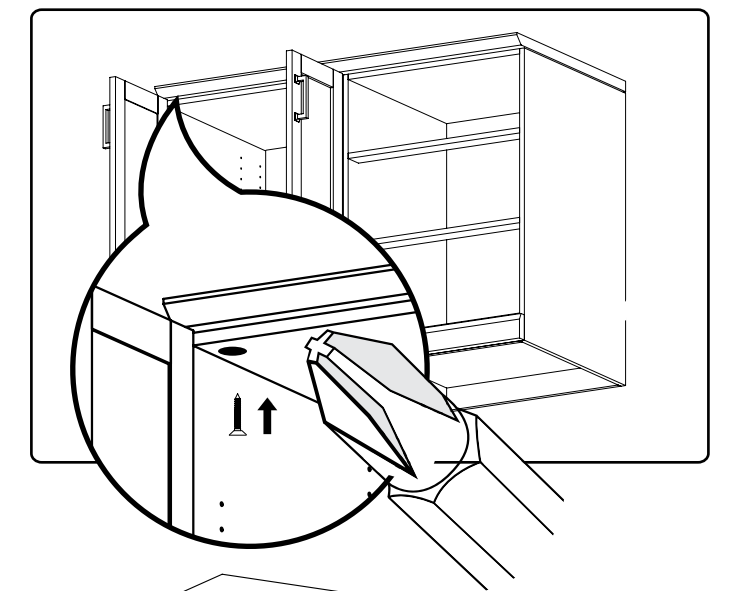

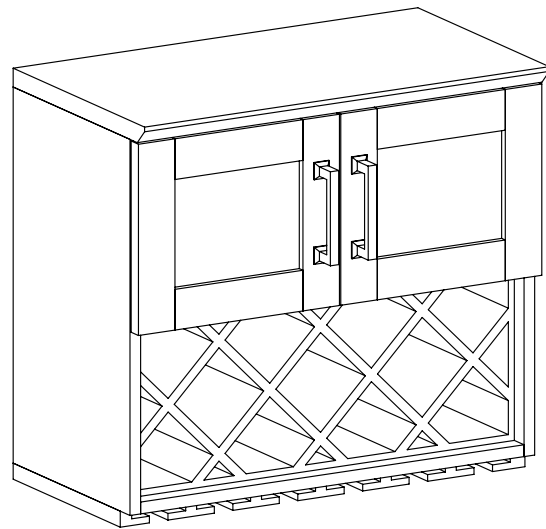

HOME BAR SERIES WALL WINE RACK



Warning: Excessive weight hazard!

Use two or more people to move, assemble, or install cabinets and locker to avoid back injury. Do not leave children unattended near cabinets. High risk of tipping if cabinets are installed incorrectly: securely attach cabinets to the wall to avoid serious injury. For assistance, call 1.877.306.8930; for U.K 0800.031.4069; e-mail at info@newageproducts.com.

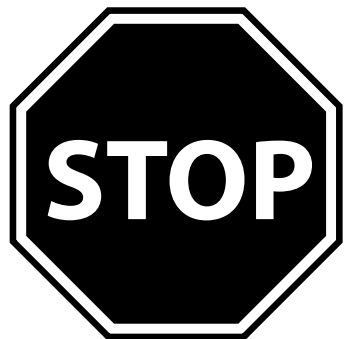

ATTENTION: Is your cabinet damaged? Need help or spare parts? For fastest service, contact NewAge Products at 1-877-306-8930; or support@newageproducts.com. Do not return to the retailer.

Weight Capacity

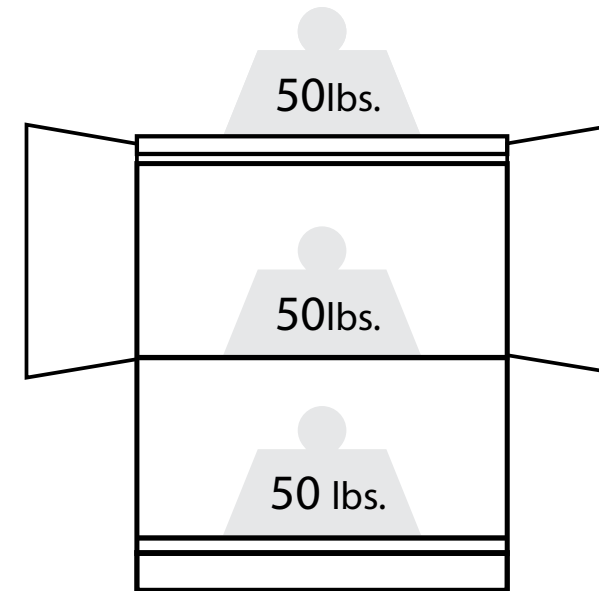

Wall
Wine Rack
Max 150 lbs.

Countertops

(for Base cabinets only.)

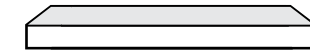

48" Countertop. Fits over 2 Cabinets

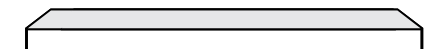

72" Countertop. Fits over 3 Cabinet



96" Countertop. Covers over 4 Cabinet

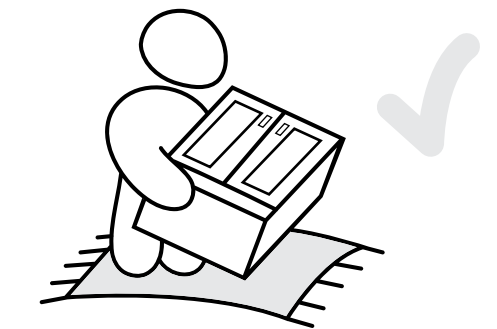
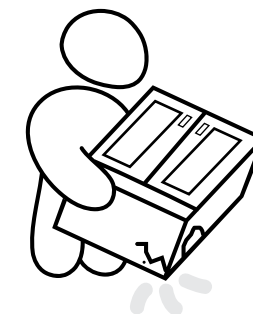
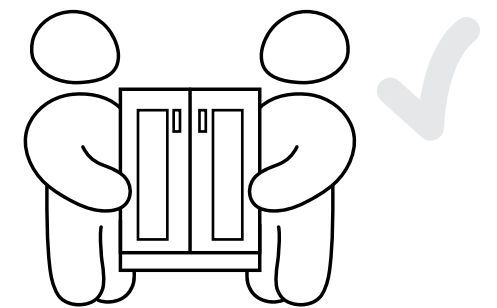
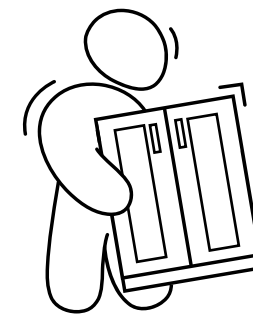

Unpacking

- Begin by placing the package on a covered flat surface.
- Remove all cardboard, foam packaging material and clear plastic bags.
- Dispose / recycle all packaging materials.
- Verify all the contents in the box and gather the required tools. See "Parts" and "Tools Needed" in the list below.

Parts Supplied	Wall Rack	Cabinet
Threaded Caps	4	
Threaded Washer	4	
Handles	2	
Handle Bolts (M4 x 22mm)	4	
#8 x 25mm Screws	4	
Lag Screw (6 mm x 55 mm)	4	

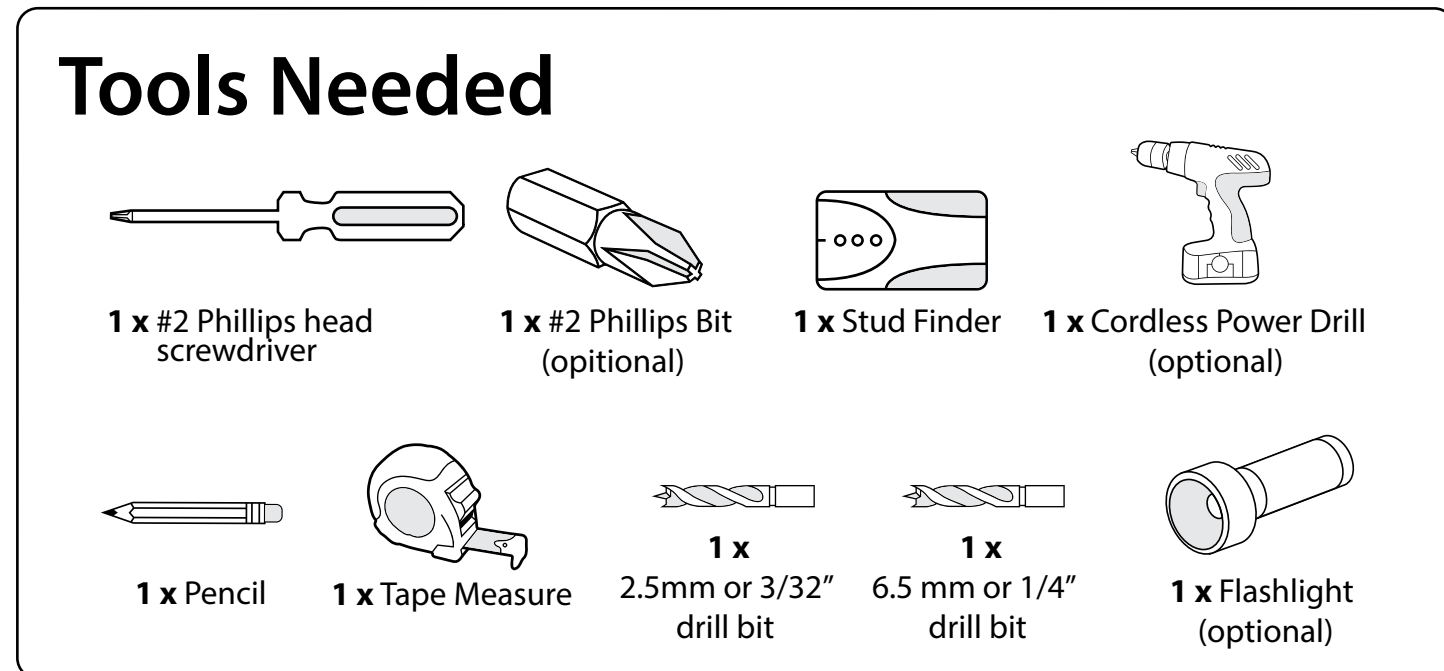
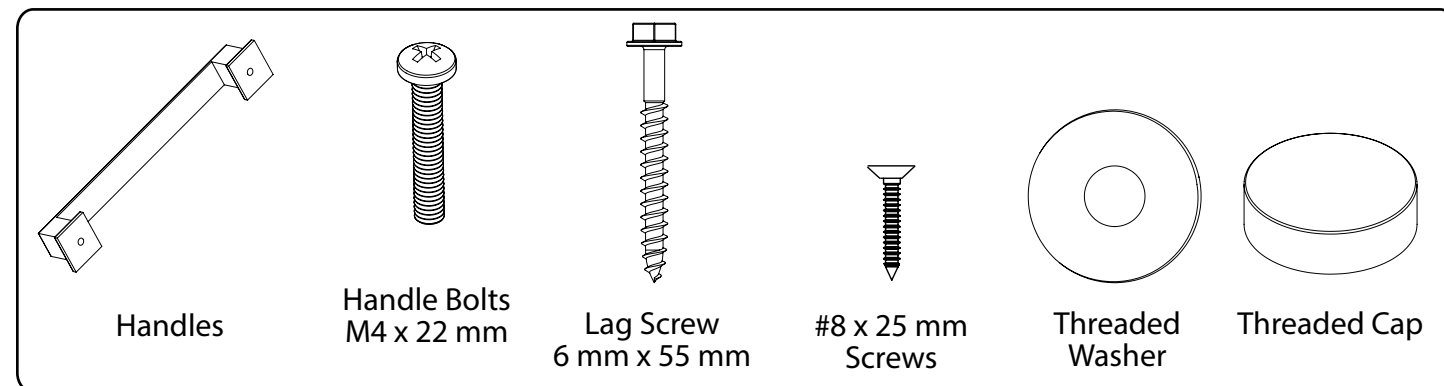

Installing the Handles

Note:
Cabinets come with handles installed on inside of drawers/doors.

1 Parts Needed.

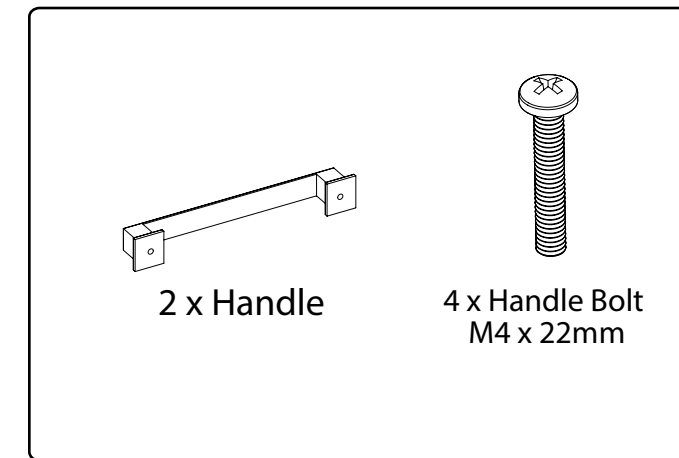

2 Align handle to holes on doors or drawers.

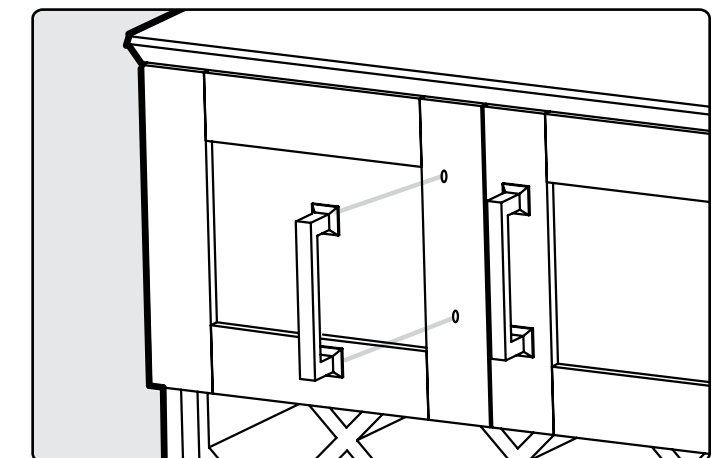

3 Screw in M4 x 22mm bolts.

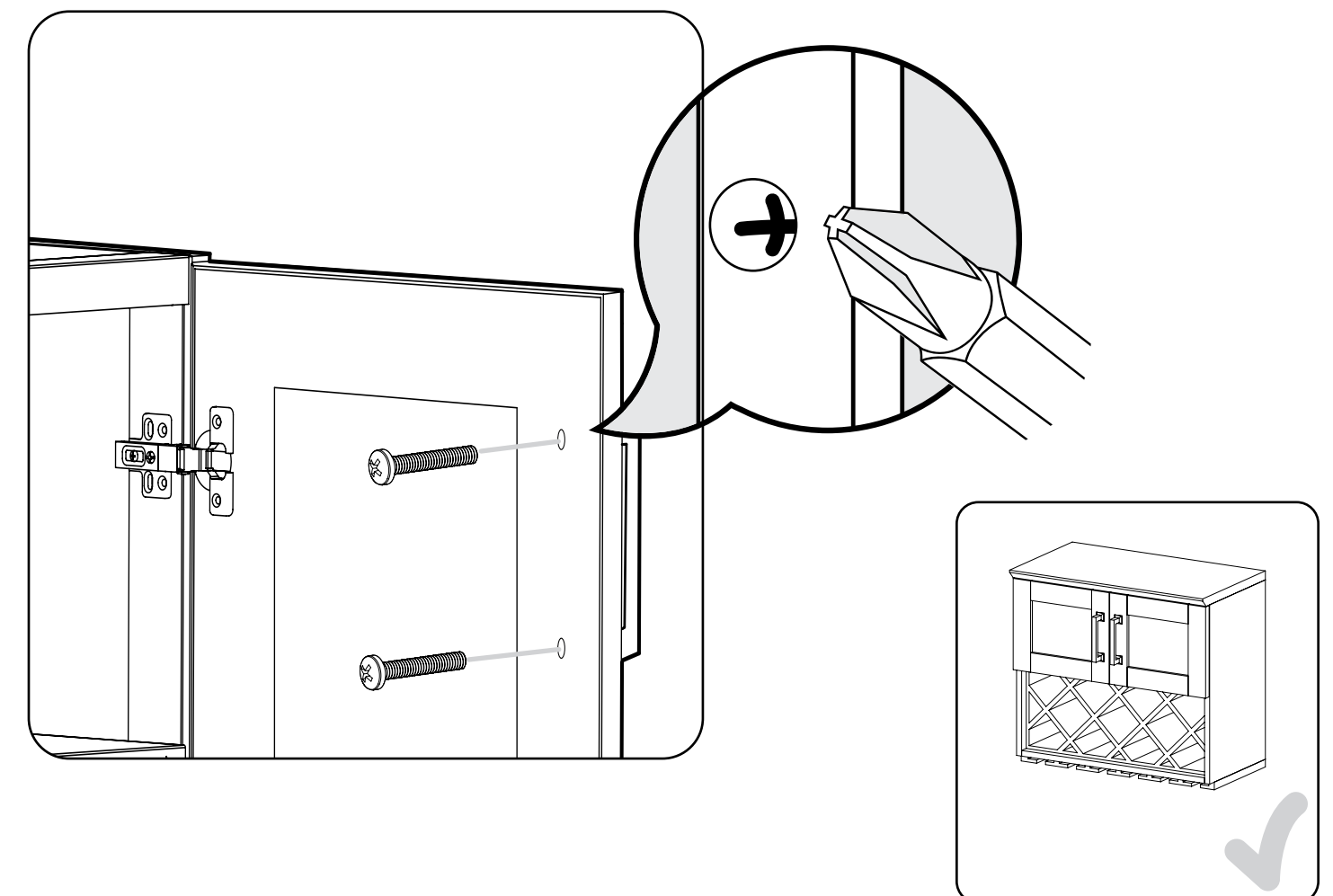

Mounting Cabinets

7 Use stud finder to locate the studs and mark the wall with a pencil.

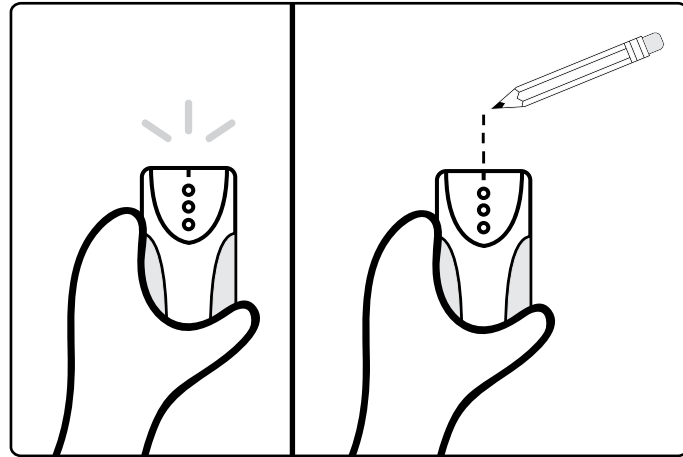

8 Gather parts.

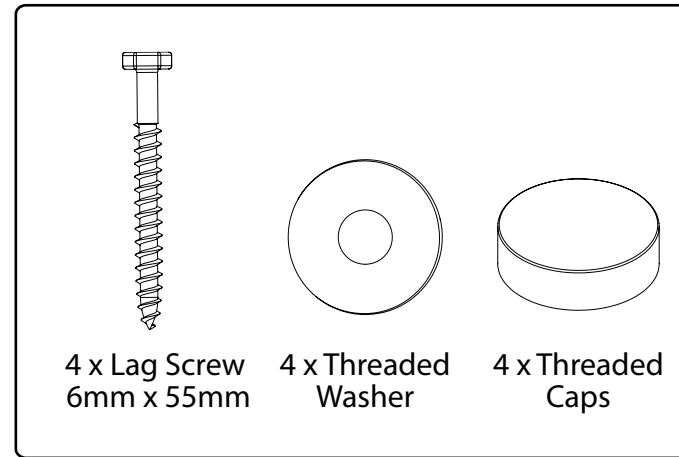

9 Near the top of the cabinet, drill 1/4" holes through the back of the cabinet that are in line with marked studs. Repeat for drilling two holes near the bottom of the cabinet.

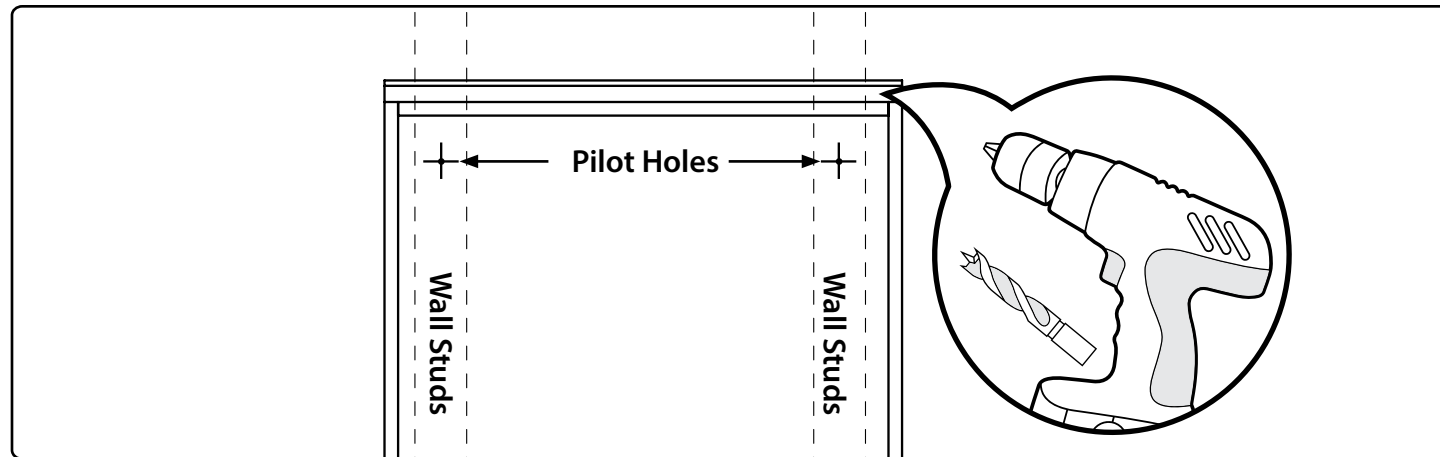

10 Place cabinet flush against wall and attach using screws and washers.

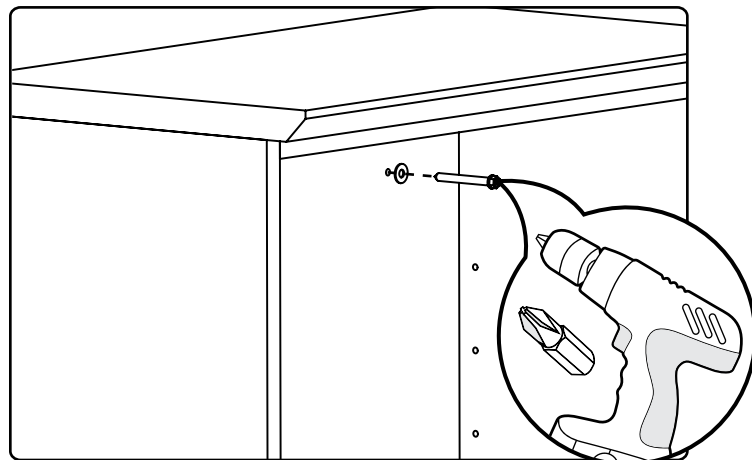

11 Use threaded caps to cover screws.

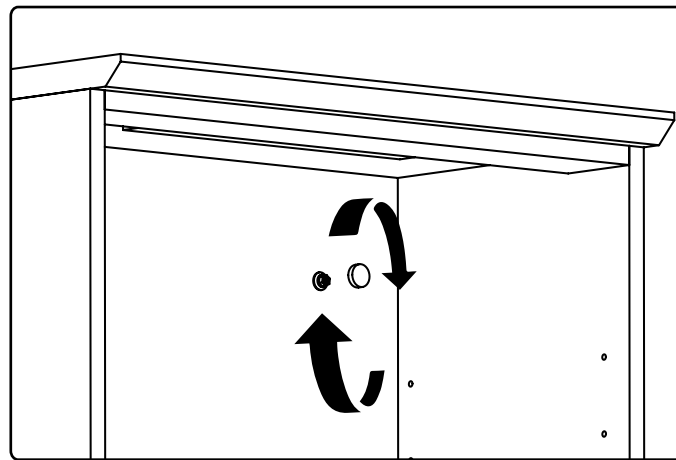

Fastening Cabinets

Note:
Remove wine rack to make attaching cabinets easier.

4 Parts Needed.

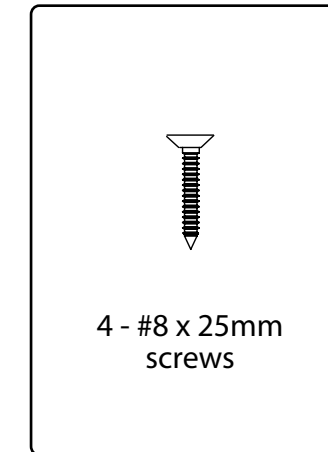

5 Drill 3/32" pilot holes on interior wall of cabinet being fastened.

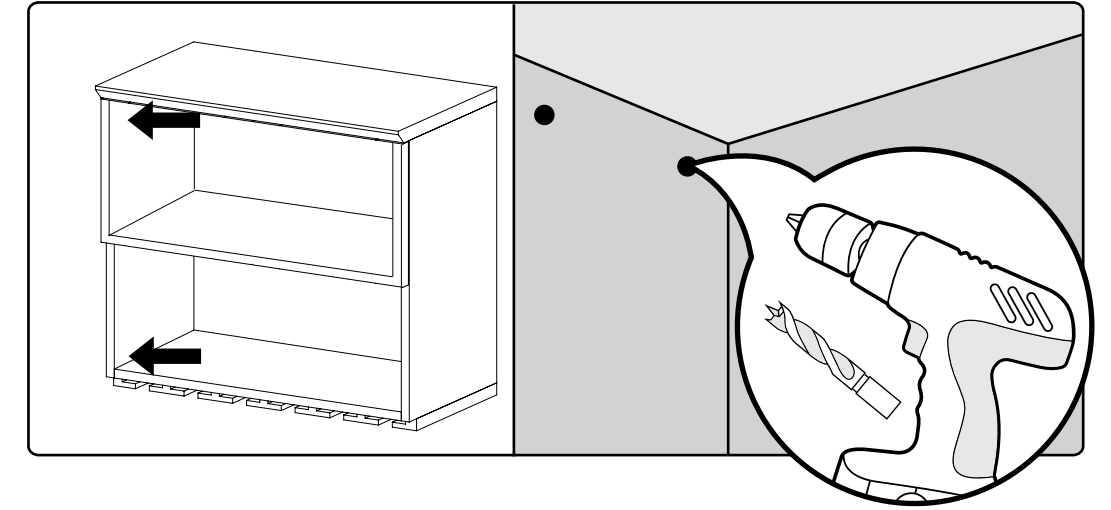

6 Using pilot hole as guides, screw into second cabinet. Do Not Over-tighten screws and Punch through other side!

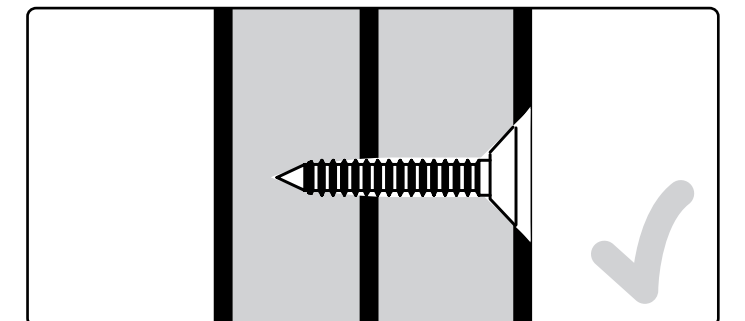
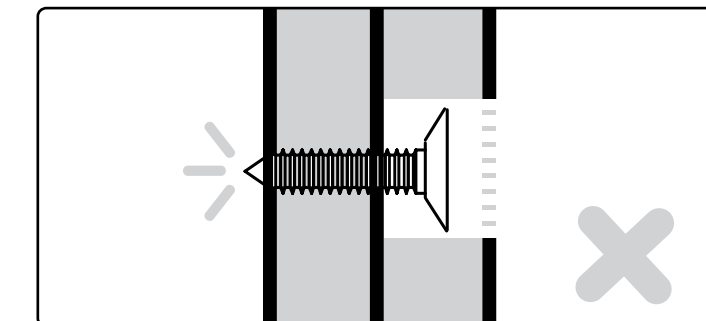
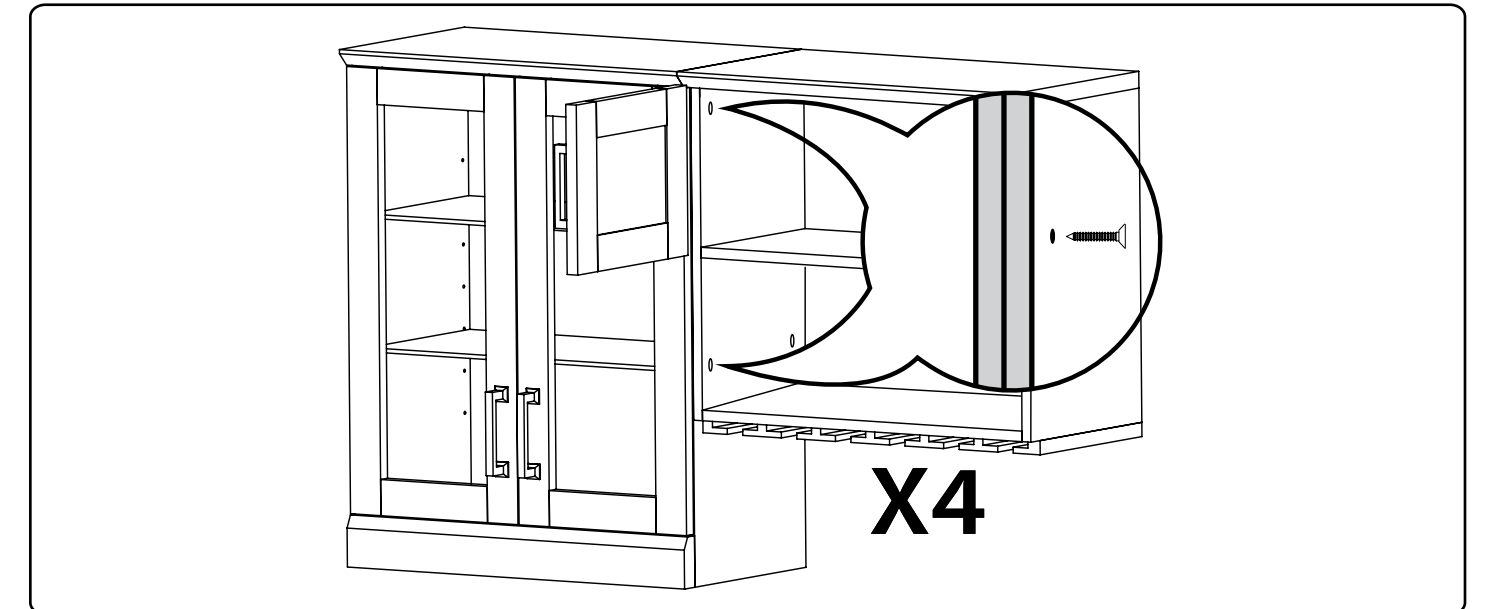

Adjusting The Door Hinges

Using a Philips screwdriver, the doors can be adjusted:
Left, right, forwards and backwards.

12 To adjust the doors left or right, turn the screw (A) clockwise or counterclockwise.

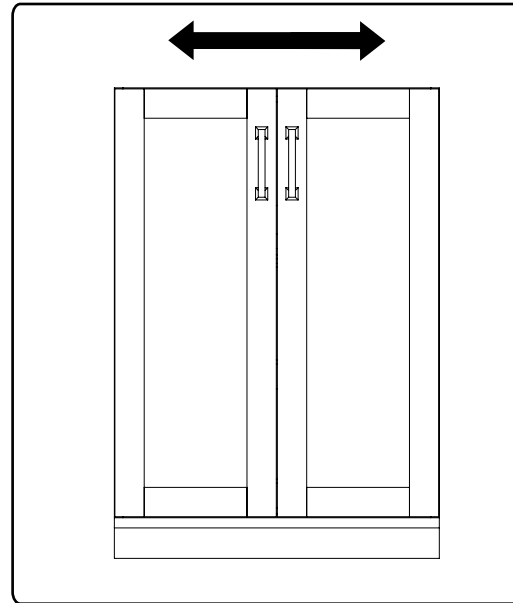
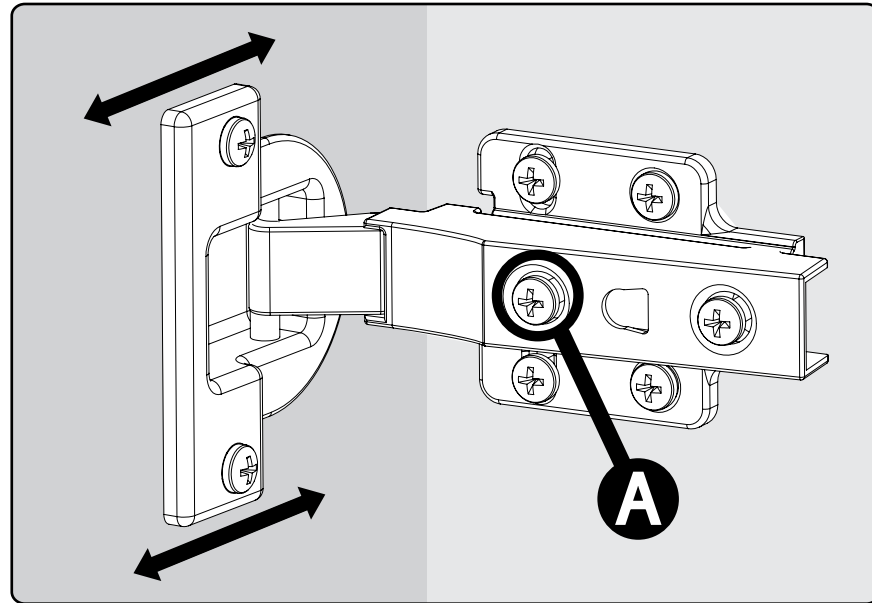

13 To adjust the gap between the doors and frame, turn the screw (B) clockwise or counterclockwise.

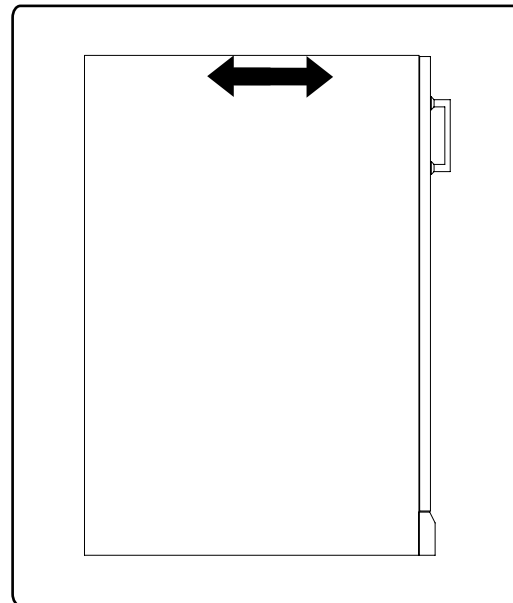
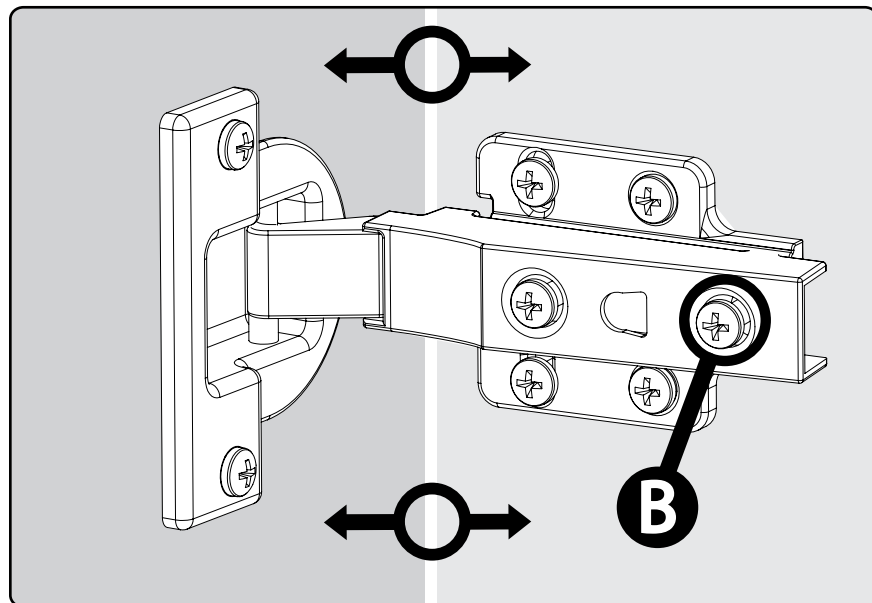

Thank you for purchasing a NewAge Product!

Please give us a call or visit online if you have any questions.

Call 1.877.306.8930; for UK 0800.031.4069; e-mail at info@newageproducts.com

LED Light Guide

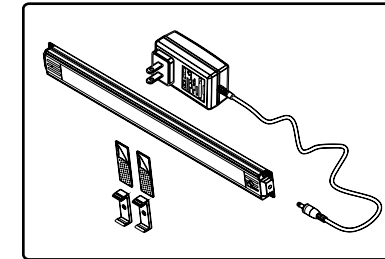

LED Light with power Adapter
SKU# 60836/60838

The adapter kit is used to connect to the electrical outlet, and contains the power on/off switch for the LED lights. It is used when one single light unit is needed or as the first light used when linking multiple light units together. It controls on/off power for all light units linked to it. Includes adapter, LED light, plastic clips, and double sided tape.

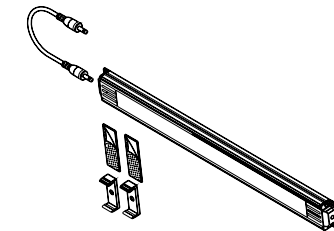

LED Light with Connector wire
SKU# 60837/60839

The connector kit is used when additional light units (up to 4) want to be linked together. It works in conjunction with and is controlled by the LED light with power adapter unit. Includes double sided tape and plastic clips.

How to connect the LED Lights

For LED Lights to work correctly, the adapter cable (A) must connect to end with on/off switch, for LED Light to be operational. Use connector cords (B) to connect additional lights. Up to 4 LED lights can be connected to one Power adapter cord (A).

NOTE: For Wall Switch Operation

If you are using a switch controlled power outlet to operate the LED Lights, the power adapter cord needs to plug into the end opposite the ON/OFF switch end.

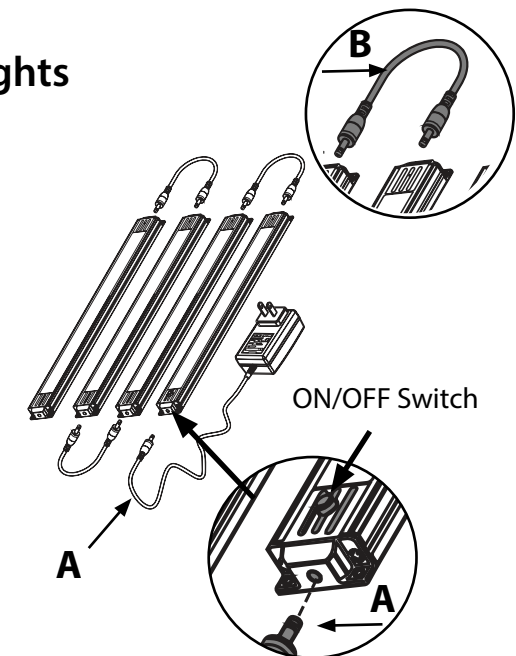

Installing LED Lights for Wall Cabinets

- 1** Method 1. Using double sided tape provided. Attach double sided tape to back of LED light bar. Peel backing off.

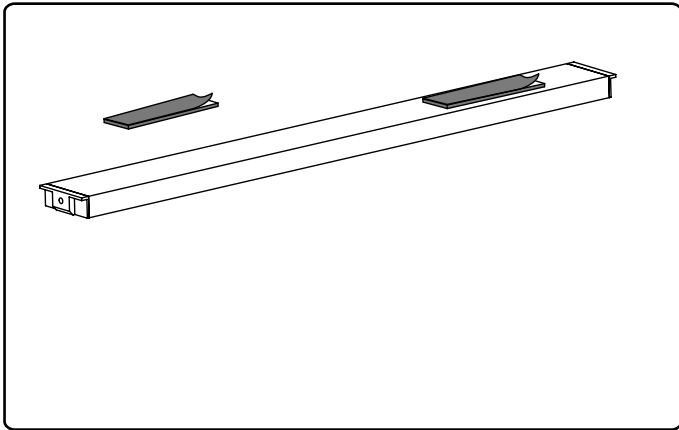

- 2** Center and press firmly 5.5", in from walls and 7.5", in from back wall.

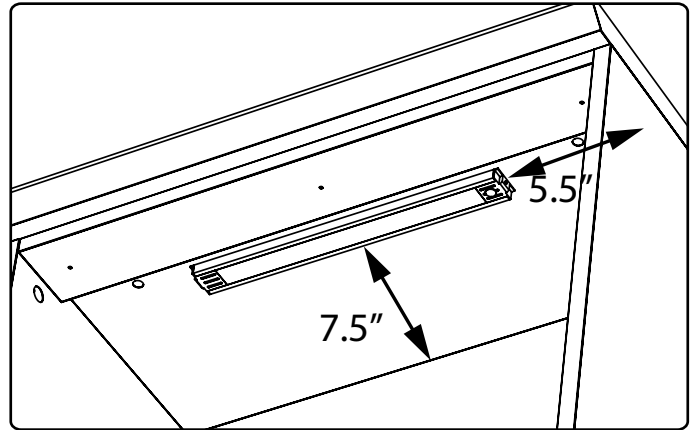

- 3** Feed connector cable through pre-drilled holes on tops of cabinet and connect at ends of LED light strips.

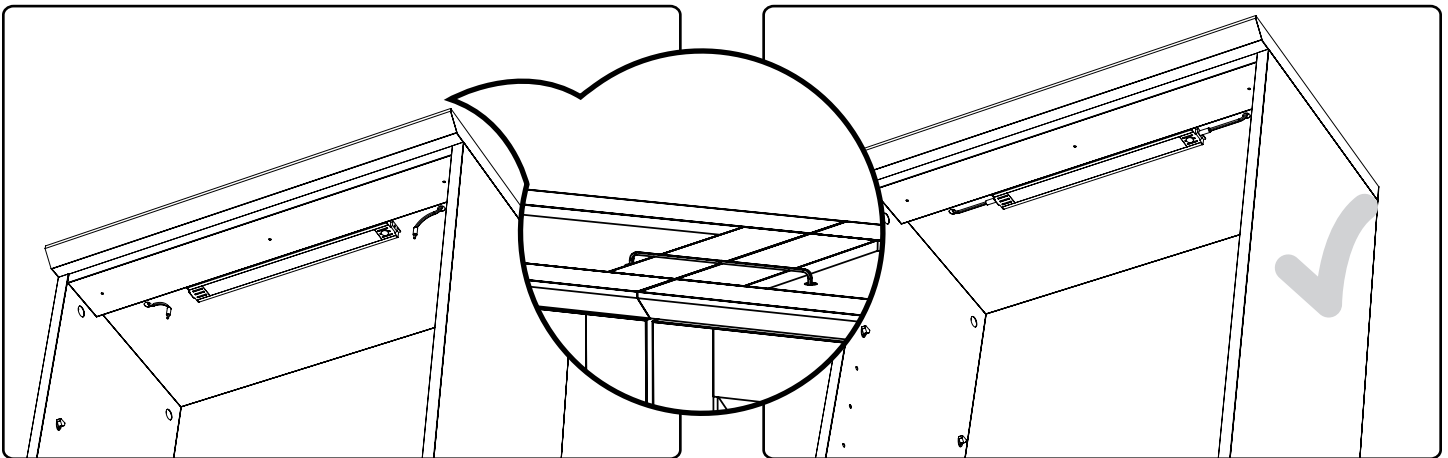

Installing LED Lights for Wall Cabinets cont.

Method 2. Using clips provided.

- 4** Predrill 3/32 holes, 8.5" in from side walls and 8" in from back wall. Attach clips using screws included in packaging.

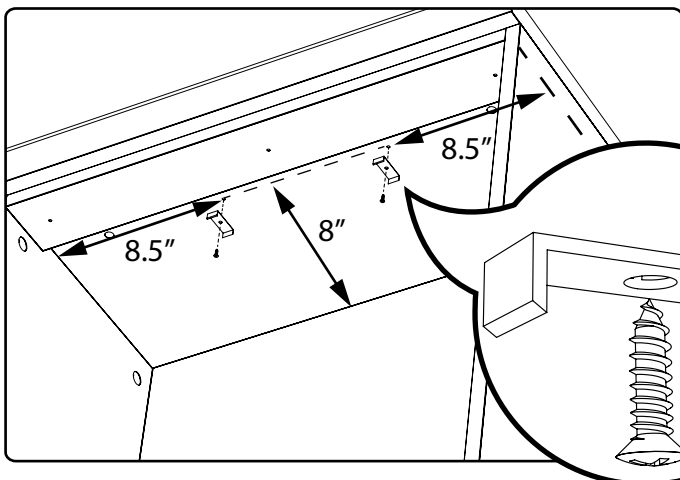

- 5** Clip LED light strip into clips. Return to Step 4. for connecting light string.

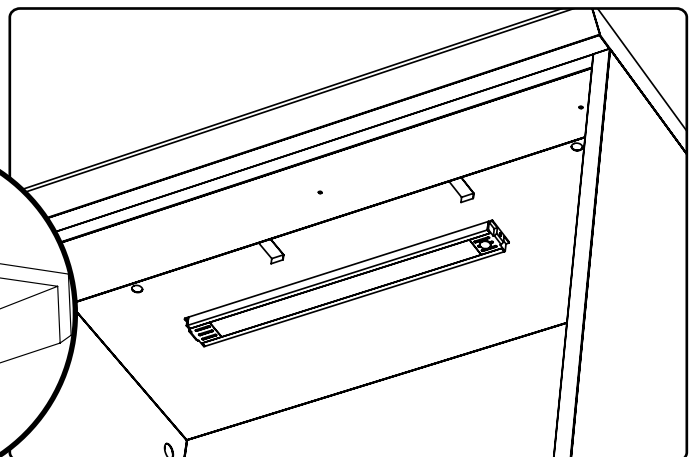



HOME BAR SERIES

SHORT WALL DISPLAY



Warning: Excessive weight hazard!

Use two or more people to move, assemble, or install cabinets and locker to avoid back injury. Do not leave children unattended near cabinets. High risk of tipping if cabinets are installed incorrectly: securely attach cabinets to the wall to avoid serious injury. For assistance, call 1.877.306.8930; for U.K 0800.031.4069; e-mail at info@newageproducts.com.



ATTENTION: Is your cabinet damaged? Need help or spare parts? For fastest service, contact NewAge Products at 1-877-306-8930; or support@newageproducts.com. Do not return to the retailer.

Weight Capacity

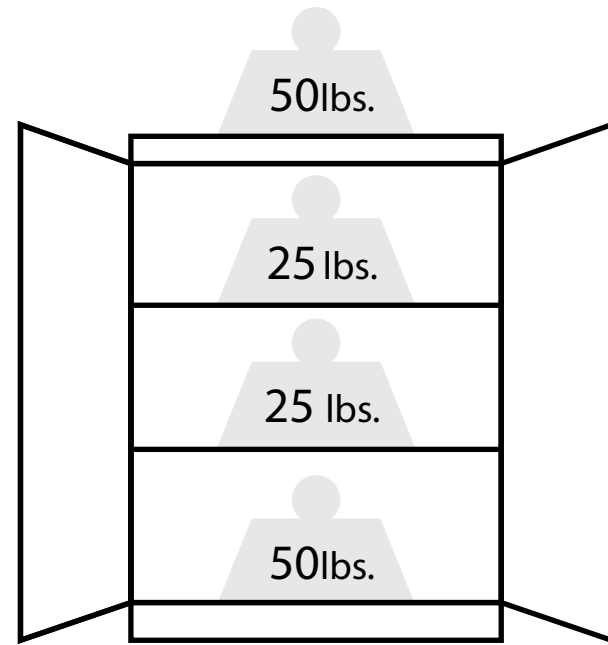

Short Display Cabinet
Max 150lbs.

Countertops

(for Base cabinets only)

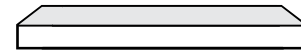

48" Countertop. Fits over 2 Cabinets

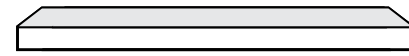

72" Countertop. Fits over 3 Cabinets

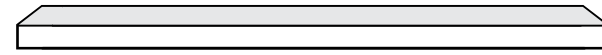

96" Countertop. Covers over 4 Cabinets

Unpacking

- Begin by placing the package on a covered flat surface.
- Remove all cardboard, foam packaging material and clear plastic bags.
- Dispose / recycle all packaging materials.
- Verify all the contents in the box and gather the required tools.
- See "Parts" and "Tools Needed" in the list below.

Parts Supplied	Tall Wall Display Cabinet
Threaded Caps	4
Threaded Washer	4
Handles	2
Handle Bolts (M4 x 22mm)	2
#8 x 25mm Screws	4
Lag Screw (6 mm x 55 mm)	4
Glass Shelves	2
Shelf Pins	10

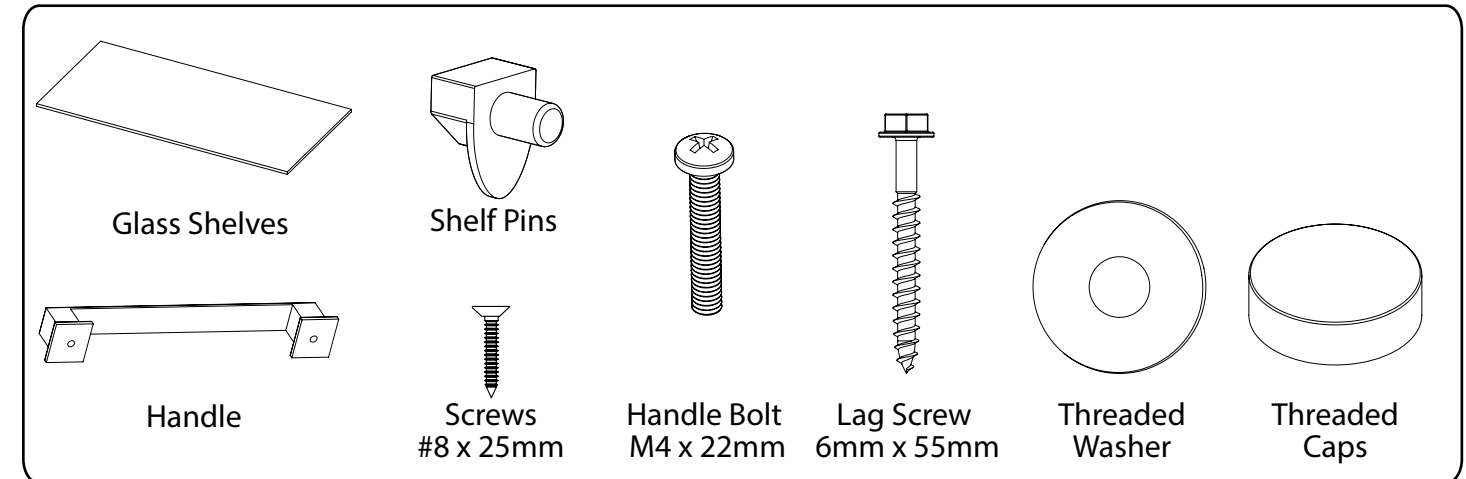

Tools Needed

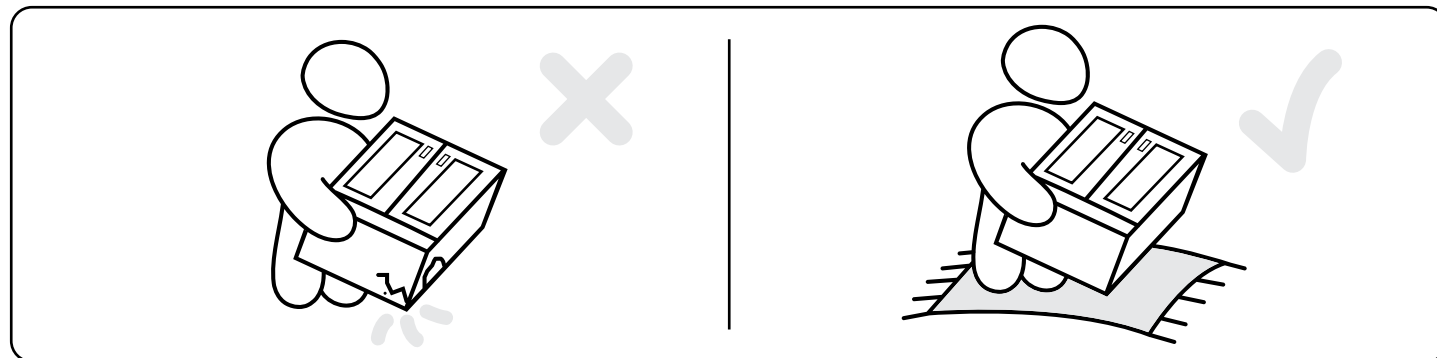
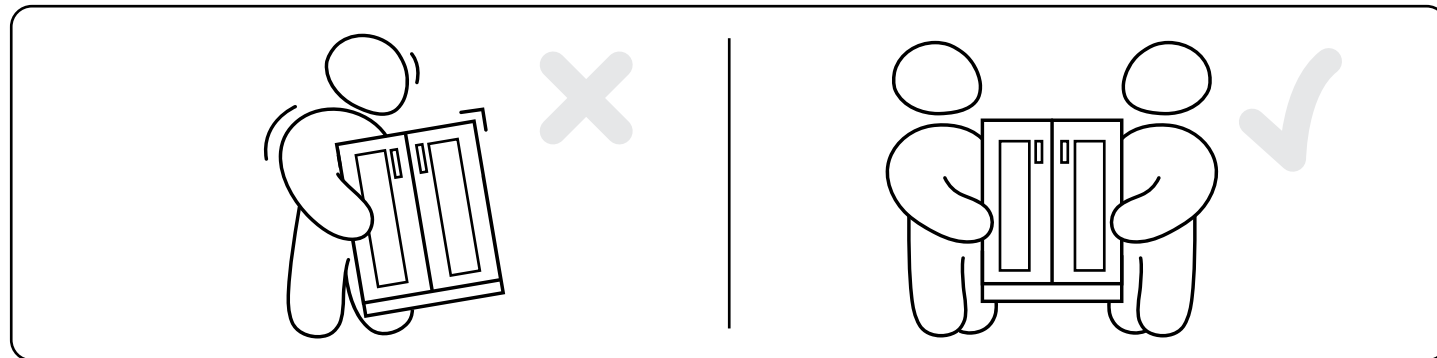
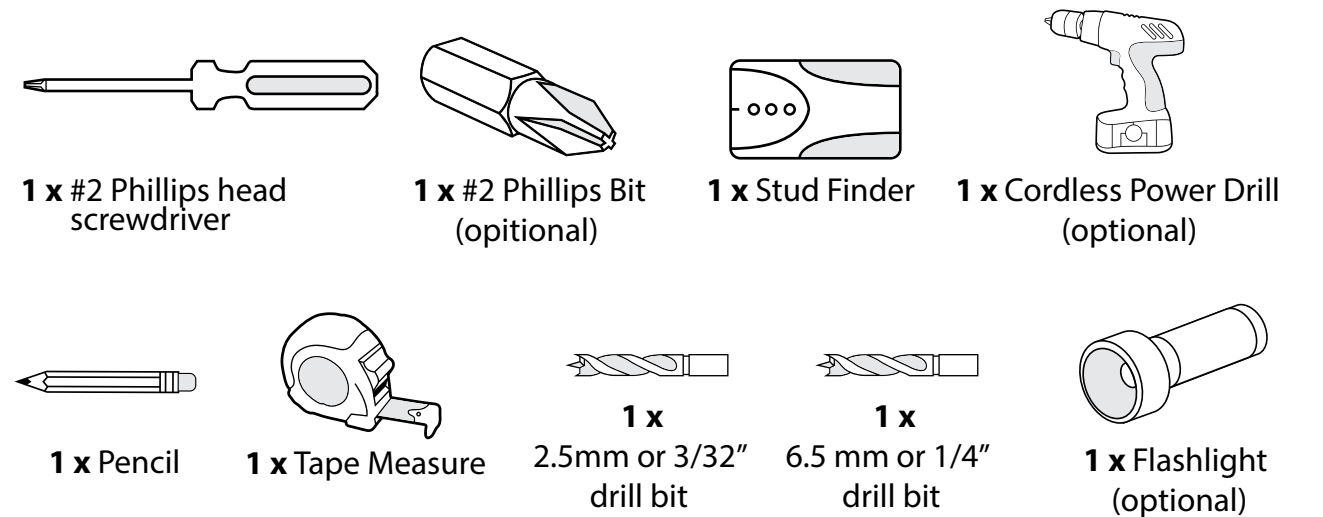

Installing the Handles

Note:
Cabinets come with handles installed on inside of drawers/doors.

1 Parts Needed.

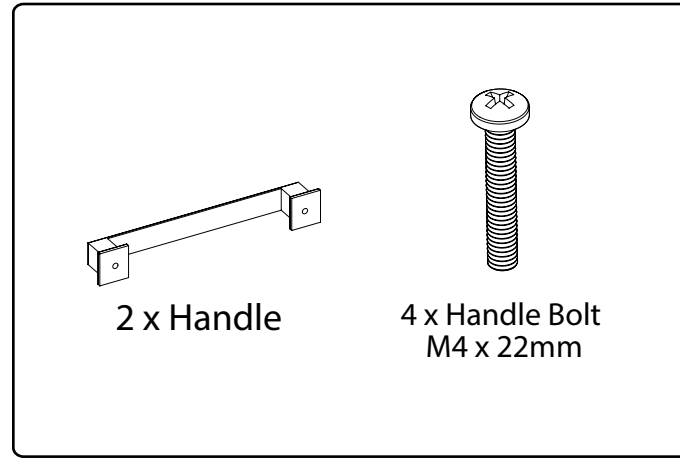

2 Align handle to holes on doors or drawers.

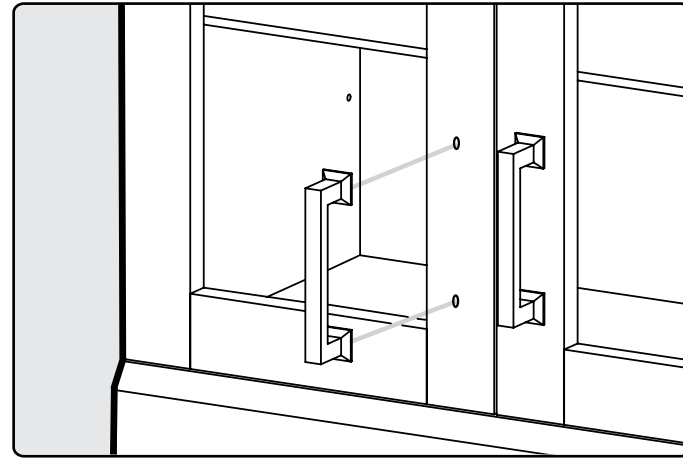

3 Screw in bolts.

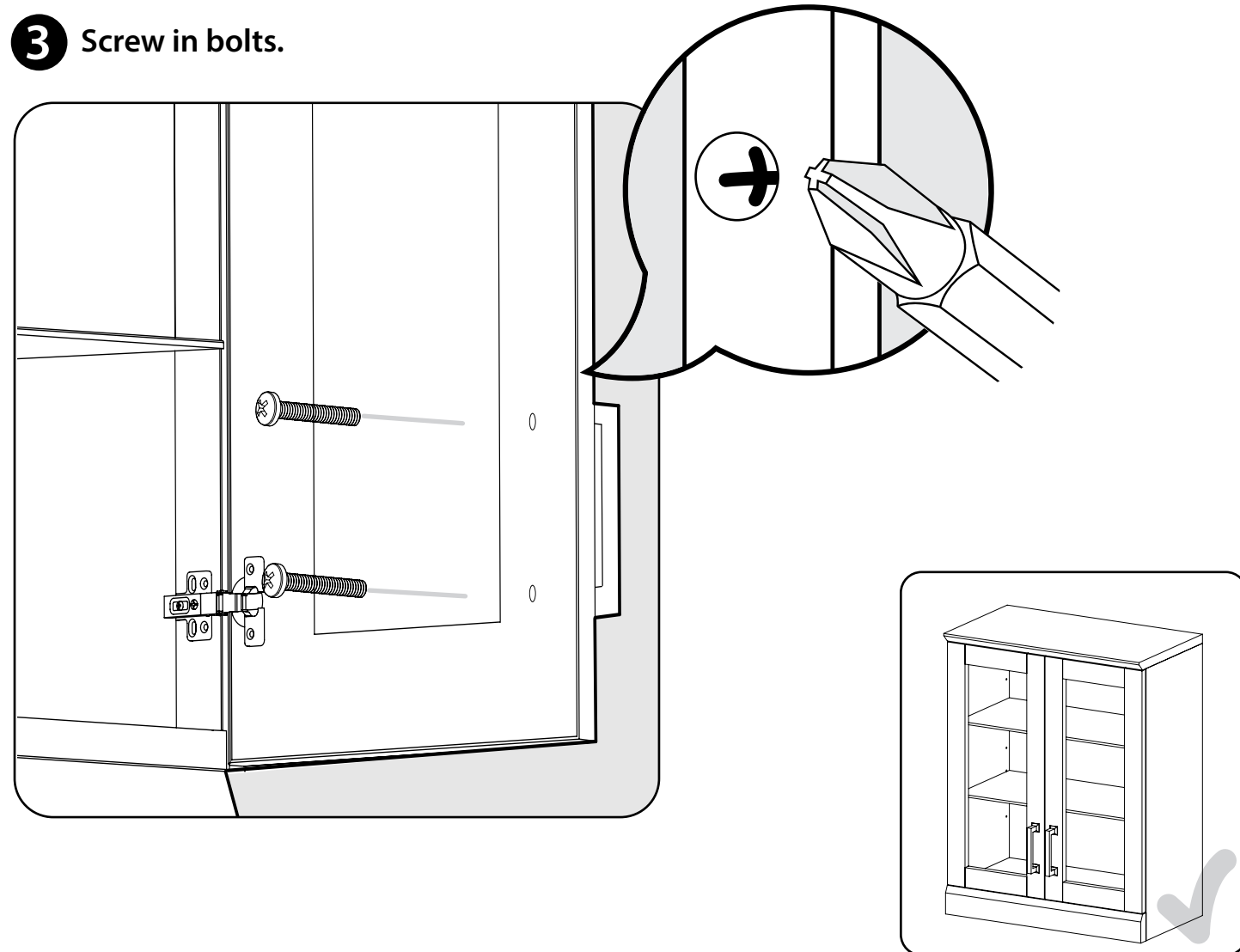

Inserting Glass Shelves

4 Open cabinet doors. Install shelf pins at desired height.

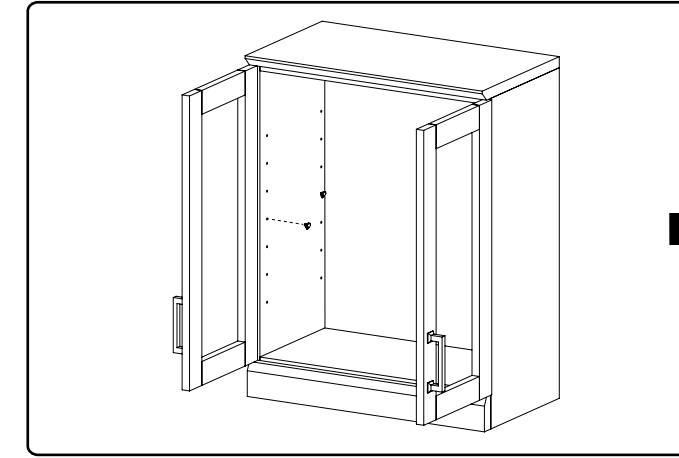

5 Ensure pins are installed at level height.

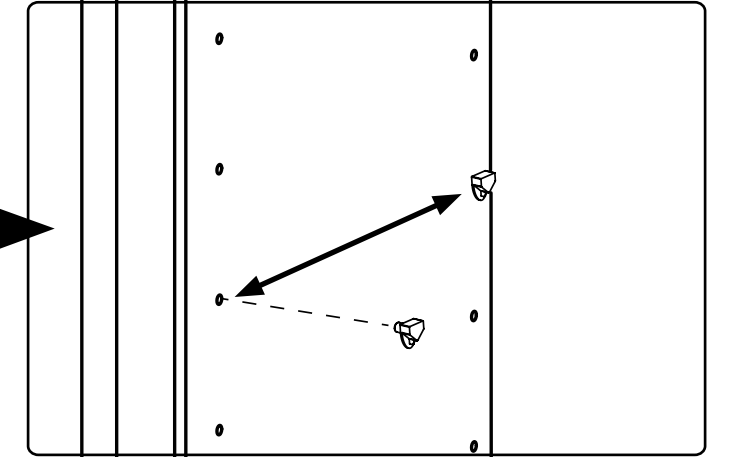

6 Insert glass shelf at a slight angle.

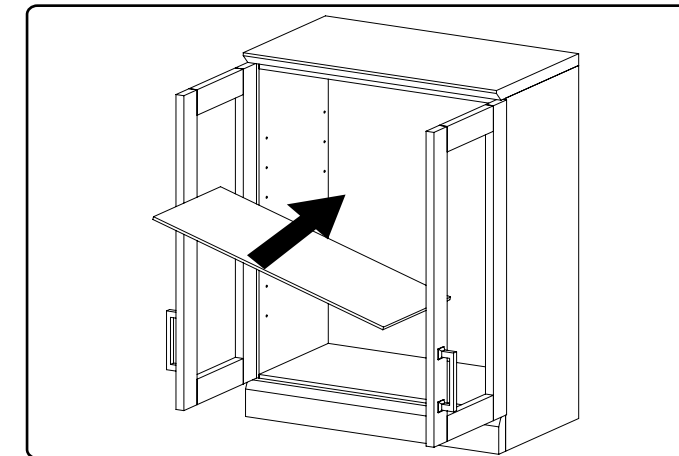

7 Position over shelf supports.

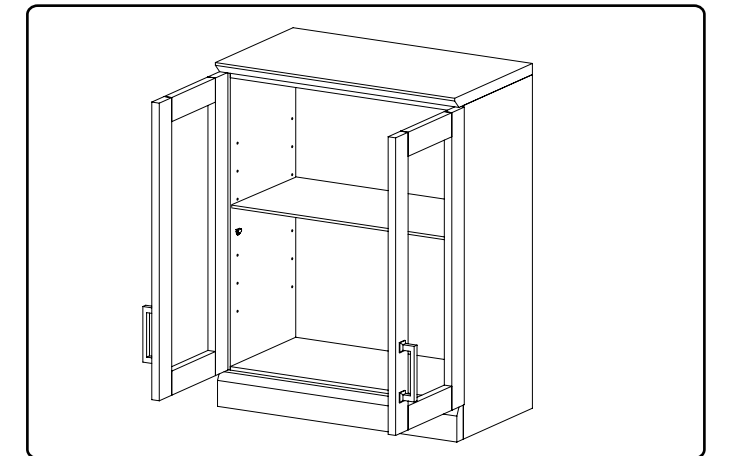

8 Lower shelf down onto shelf supports.

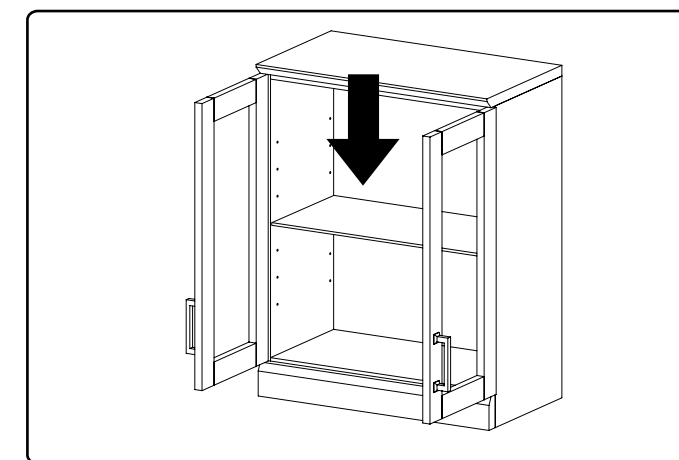

9 Repeat steps 1-4 for second shelf.

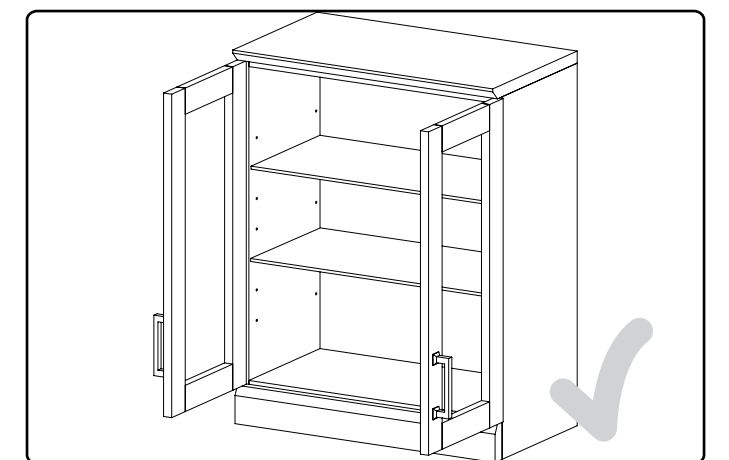

Mounting Cabinets

10 Use stud finder to locate the studs and mark the wall with a pencil.

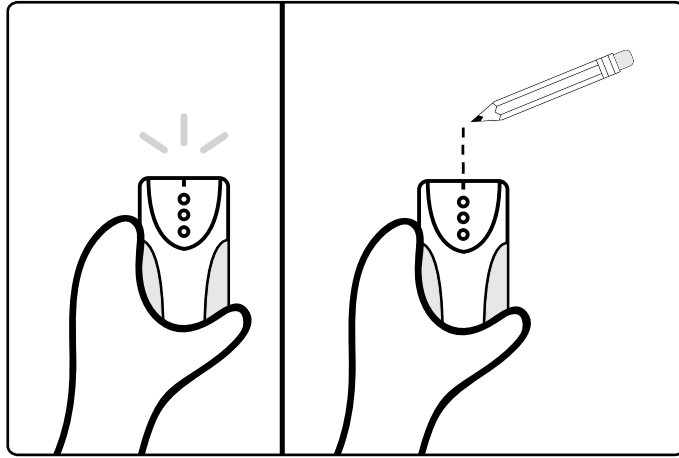

11 Gather parts.

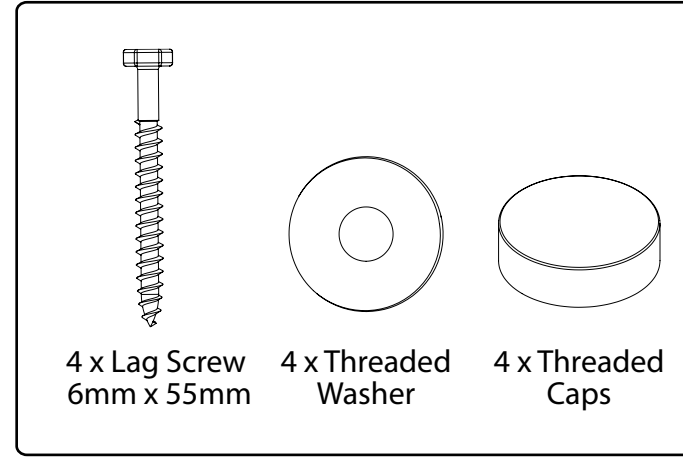

12 Near the top of the cabinet, drill 1/4" holes through the back of the cabinet that are in line with marked studs. Repeat for drilling two holes near the bottom of the cabinet.

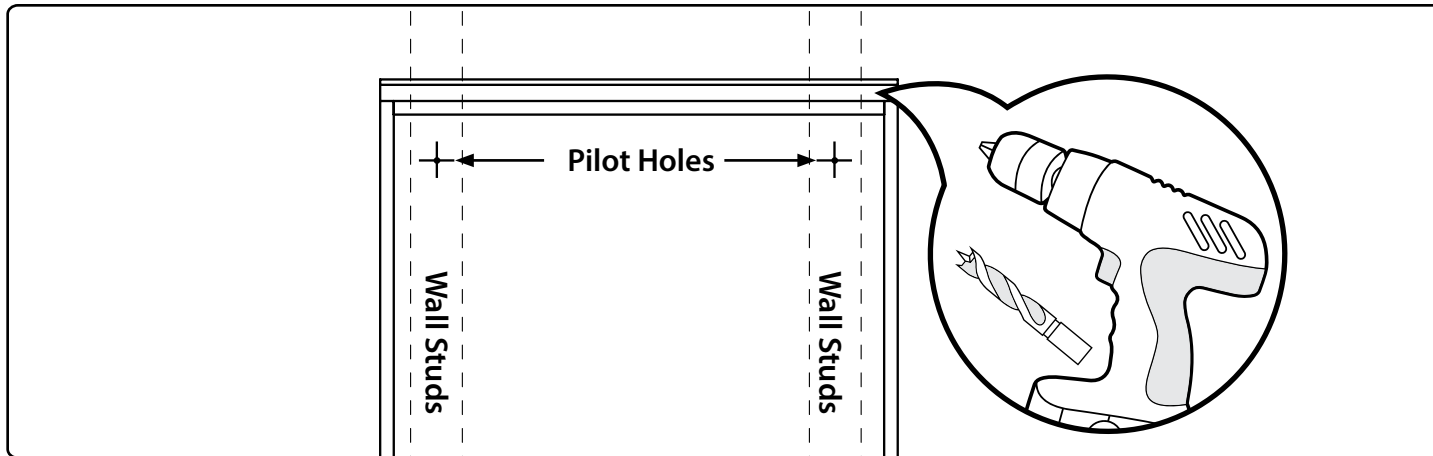

13 Place cabinet flush against wall and attach using screws and washers.

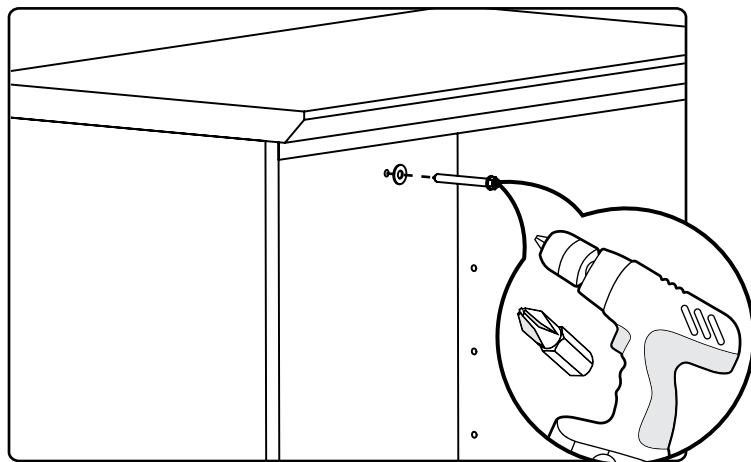

14 Use threaded caps to cover screws.

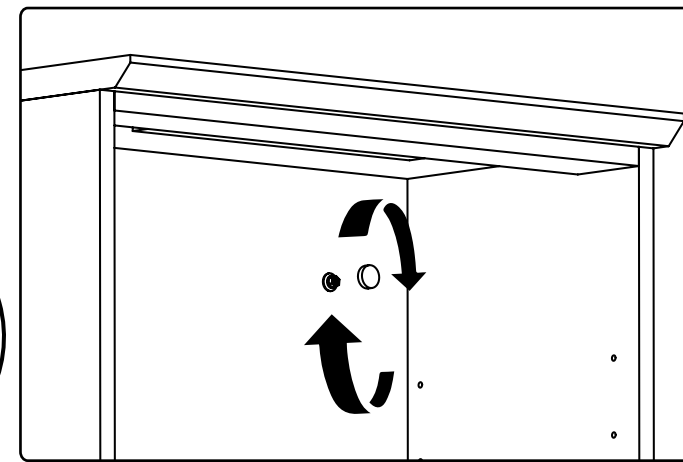

Fastening Cabinets

Note:
All shelves must be removed prior to fastening cabinets together.

15 Parts Needed.

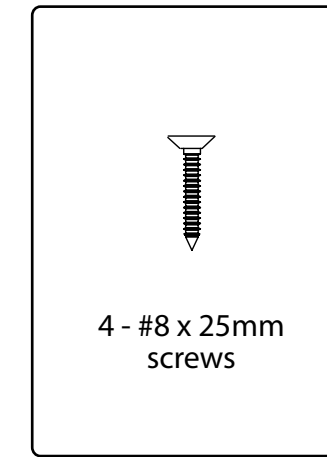

16 Drill 3/32" pilot holes on interior wall of cabinet being fastened.

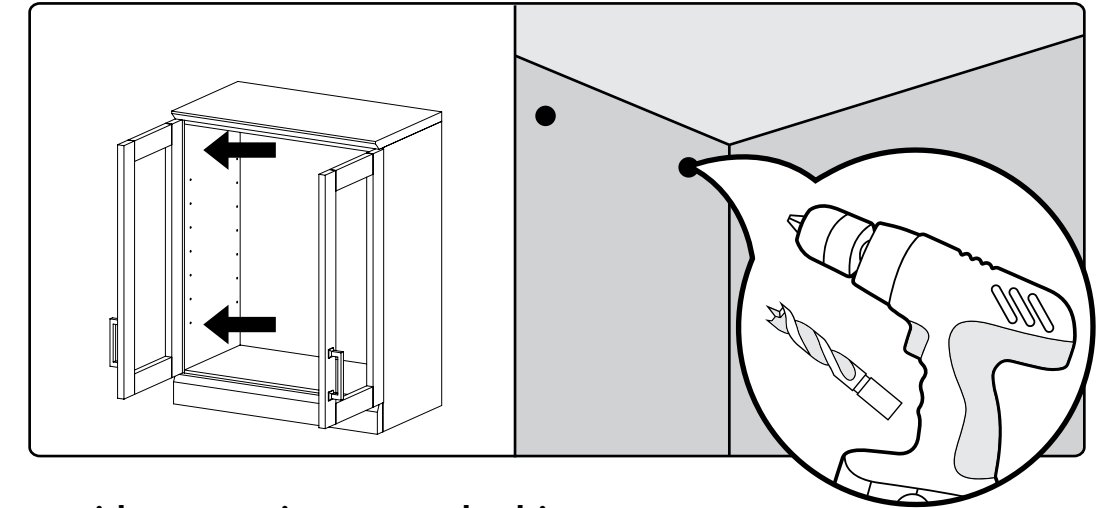

17 Using pilot hole as guides, screw into second cabinet. Do Not Over-tighten screws and Punch through other side!

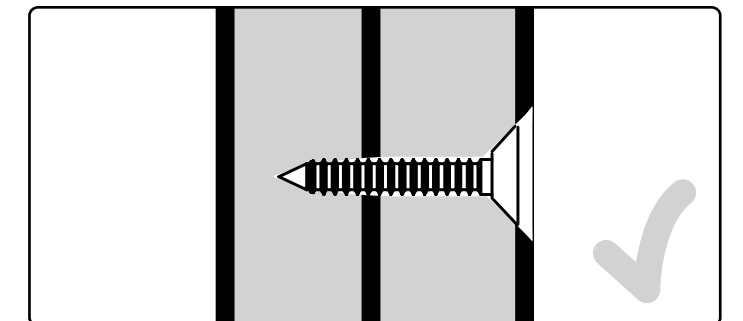
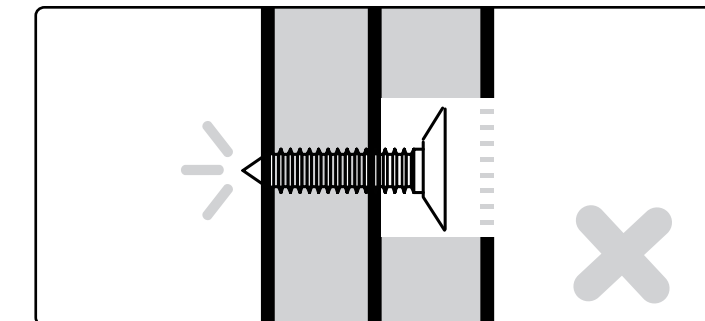
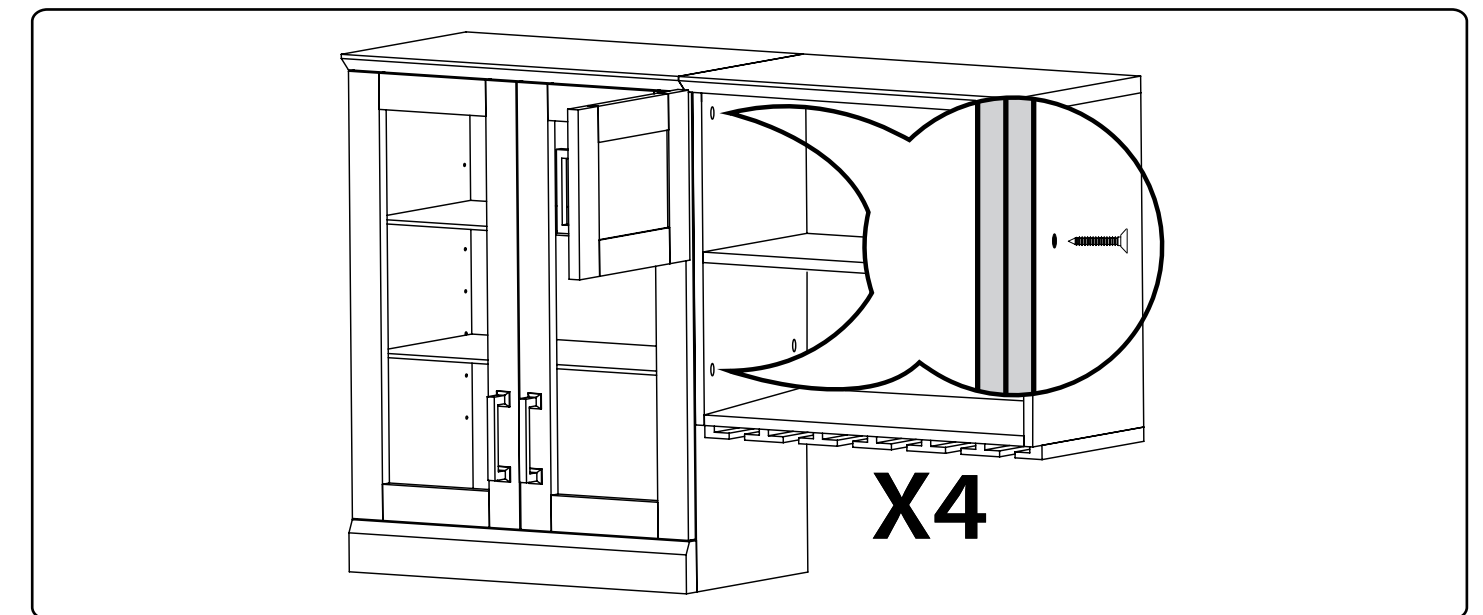

Adjusting The Door Hinges

Using a Philips screwdriver, the doors can be adjusted:
Left, right, forwards and backwards.

18 To adjust the doors left or right, turn the screw (A) clockwise or counterclockwise.

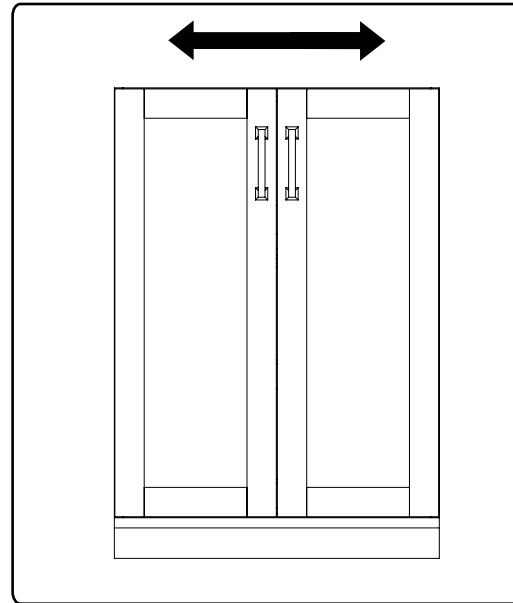
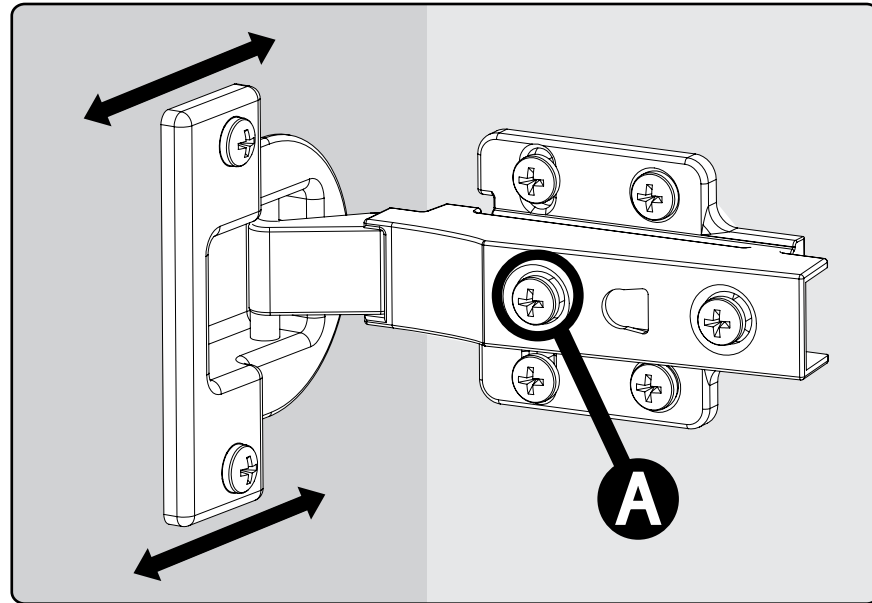

19 To adjust the gap between the doors and frame, turn the screw (B) clockwise or counterclockwise.

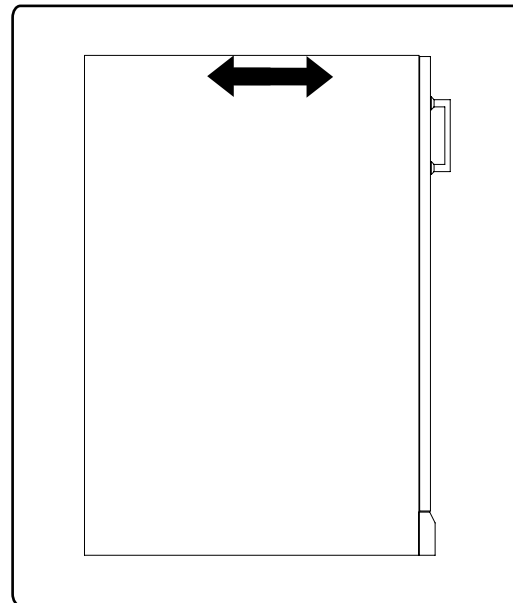
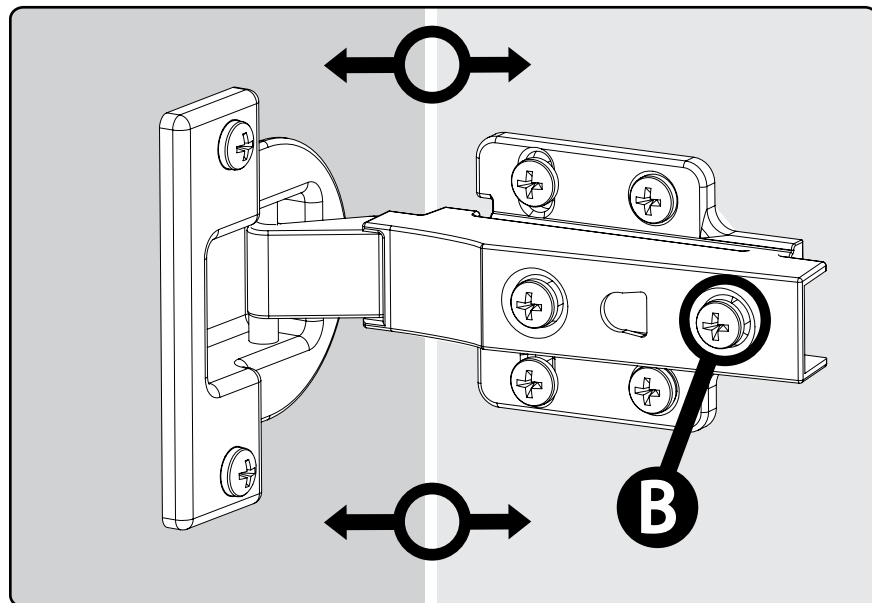

Thank you for purchasing a NewAge Product!

Please give us a call or visit online if you have any questions.

Call 1.877.306.8930; for UK 0800.031.4069; e-mail at info@newageproducts.com

LED Light Guide

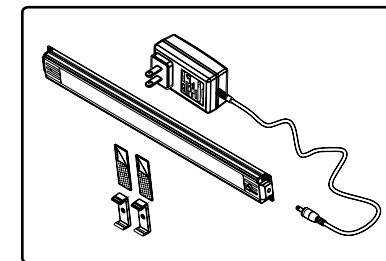

LED Light with power Adapter
SKU# 60836/60838

The adapter kit is used to connect to the electrical outlet, and contains the power on/off switch for the LED lights. It is used when one single light unit is needed or as the first light used when linking multiple light units together. It controls on/off power for all light units linked to it. Includes adapter, LED light, plastic clips, and double sided tape.

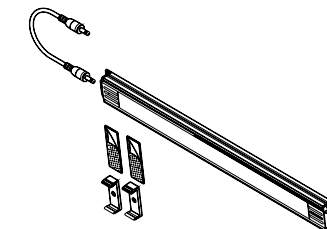

LED Light with Connector wire
SKU# 60837/60839

The connector kit is used when additional light units (up to 4) want to be linked together. It works in conjunction with and is controlled by the LED light with power adapter unit. Includes double sided tape and plastic clips.

How to connect the LED Lights

For LED Lights to work correctly, the adapter cable (A) must connect to end with on/off switch, for LED Light to be operational. Use connector cords (B) to connect additional lights. Up to 4 LED lights can be connected to one Power adapter cord (A).

NOTE: For Wall Switch Operation

If you are using a switch controlled power outlet to operate the LED Lights, the power adapter cord needs to plug into the end opposite the ON/OFF switch end.

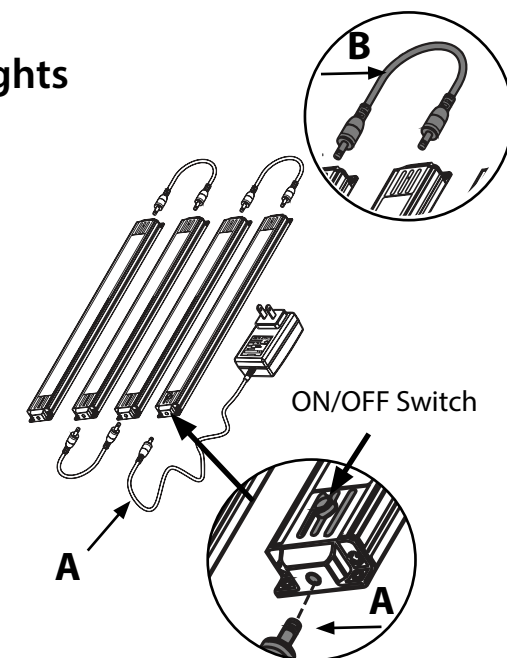

Installing LED Lights for Wall Cabinets

- 1** Method 1. Using double sided tape provided. Attach double sided tape to back of LED light bar. Peel backing off.

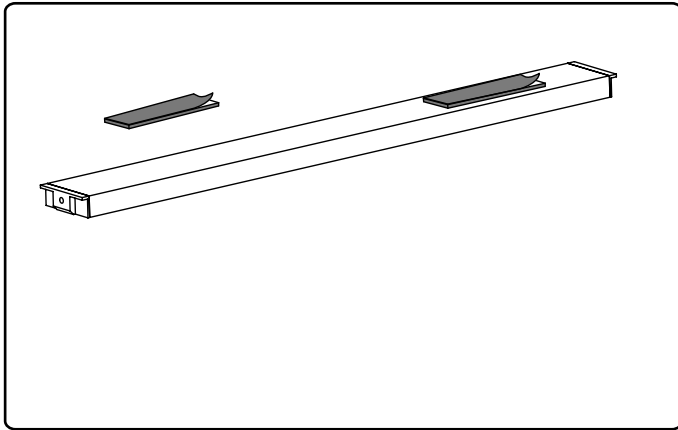

- 2** Center and press firmly 5.5", in from walls and 7.5", in from back wall.

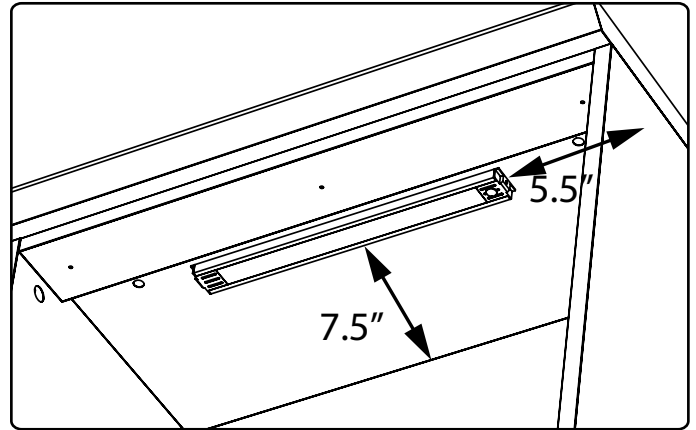

- 3** Feed connector cable through pre-drilled holes on tops of cabinet and connect at ends of LED light strips.

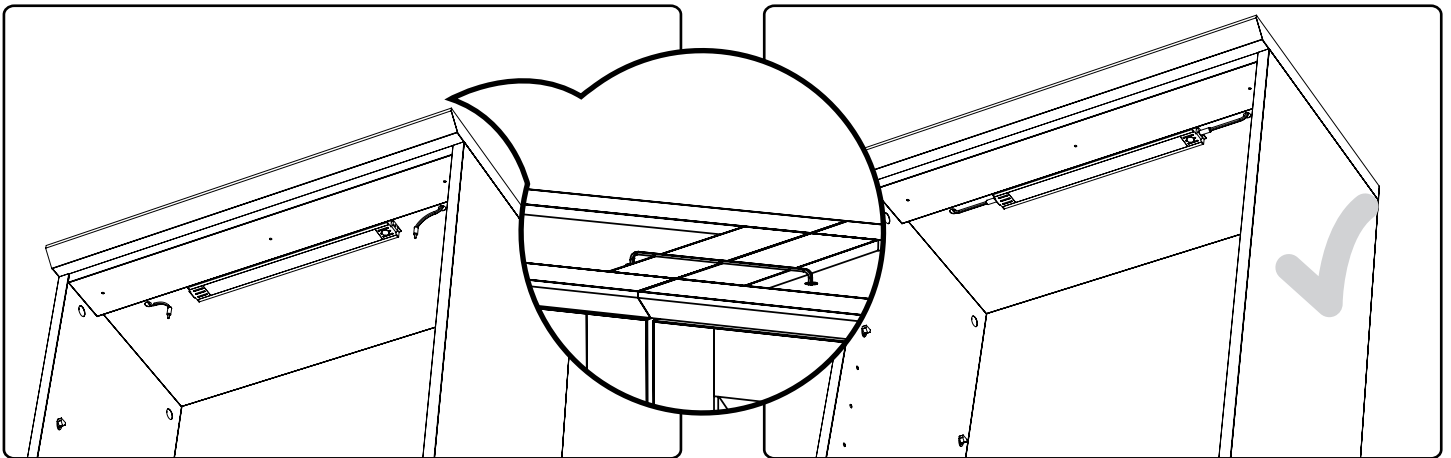

Installing LED Lights for Wall Cabinets cont.

Method 2. Using clips provided.

- 4** Predrill 3/32 holes, 8.5" in from side walls and 8" in from back wall. Attach clips using screws included in packaging.

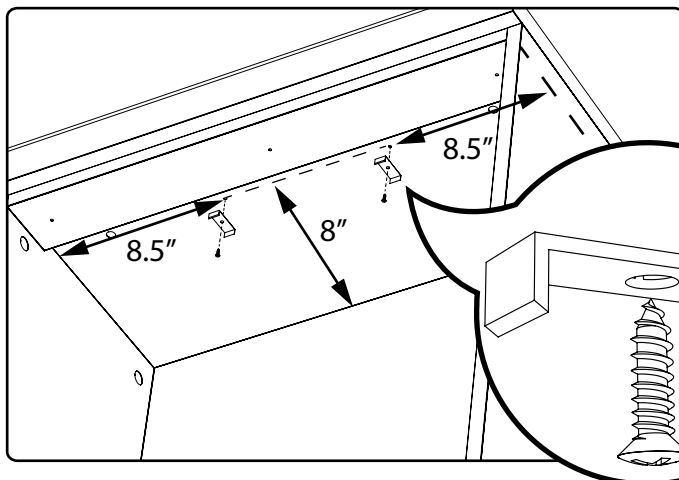

- 5** Clip LED light strip into clips. Return to Step 4. for connecting light string.

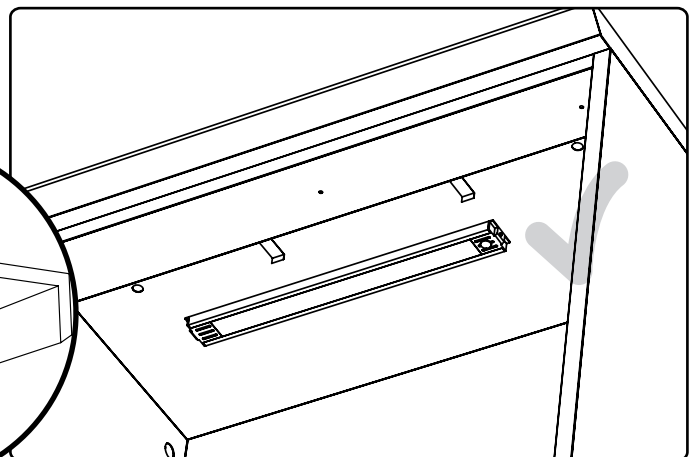

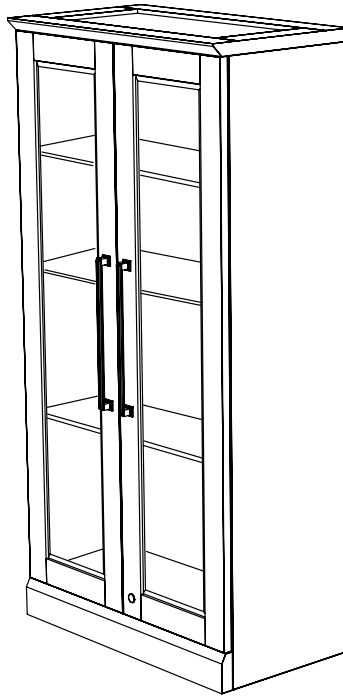

NEWAGE
PRODUCTS INC.

HOME BAR SERIES

TALL WALL DISPLAY



Warning: Excessive weight hazard!

Use two or more people to move, assemble, or install cabinets and locker to avoid back injury. Do not leave children unattended near cabinets. High risk of tipping if cabinets are installed incorrectly: securely attach cabinets to the wall to avoid serious injury. For assistance, call 1.877.306.8930; for U.K 0800.031.4069; e-mail at info@newageproducts.com.



ATTENTION: Is your cabinet damaged? Need help or spare parts? For fastest service, contact NewAge Products at 1-877-306-8930; or support@newageproducts.com. Do not return to the retailer.

Weight Capacity

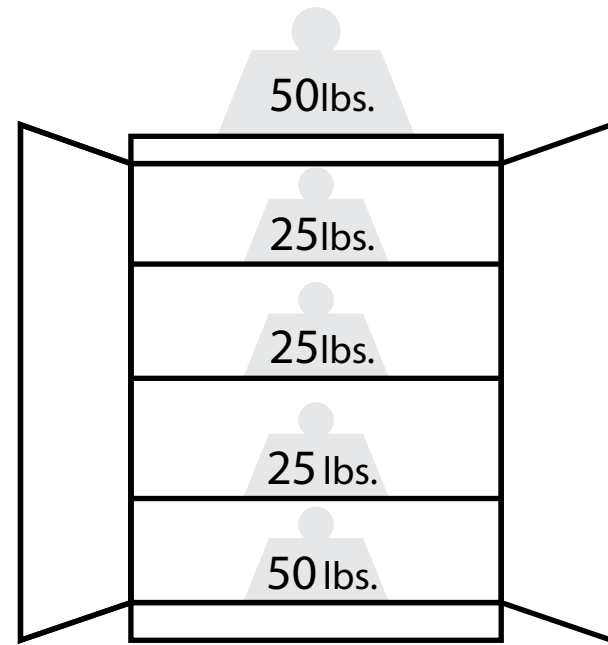

Tall Display Cabinet
Max 175 lbs.

Countertops

(for Base cabinets only.)

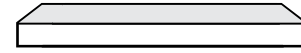

48" Countertop. Fits over 2 Cabinets

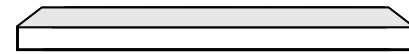

72" Countertop. Fits over 3 Cabinets

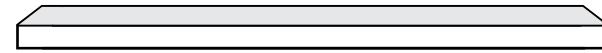

96" Countertop. Covers over 4 Cabinets

Unpacking

- Begin by placing the package on a covered flat surface.
- Remove all cardboard, foam packaging material and clear plastic bags.
- Dispose / recycle all packaging materials.
- Verify all the contents in the box and gather the required tools.
- See "Parts" and "Tools Needed" in the list below.

Parts Supplied	Tall Wall Display Cabinet
Threaded Caps	4
Threaded Washer	4
Handles	2
Handle Bolts (M4 x 22mm)	4
#8 x 25mm Screws	4
Lag Screw (6 mm x 55 mm)	4
Glass Shelves	3
Shelf Pins	14

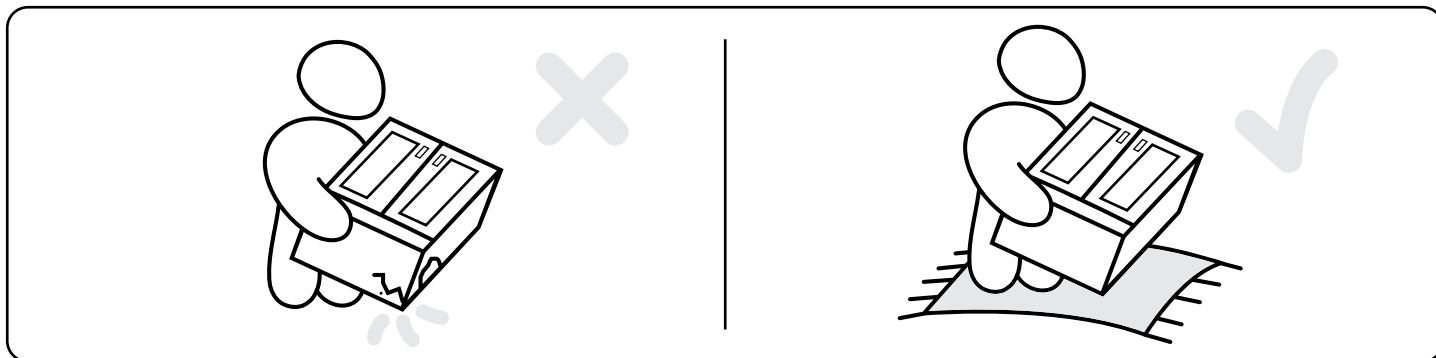
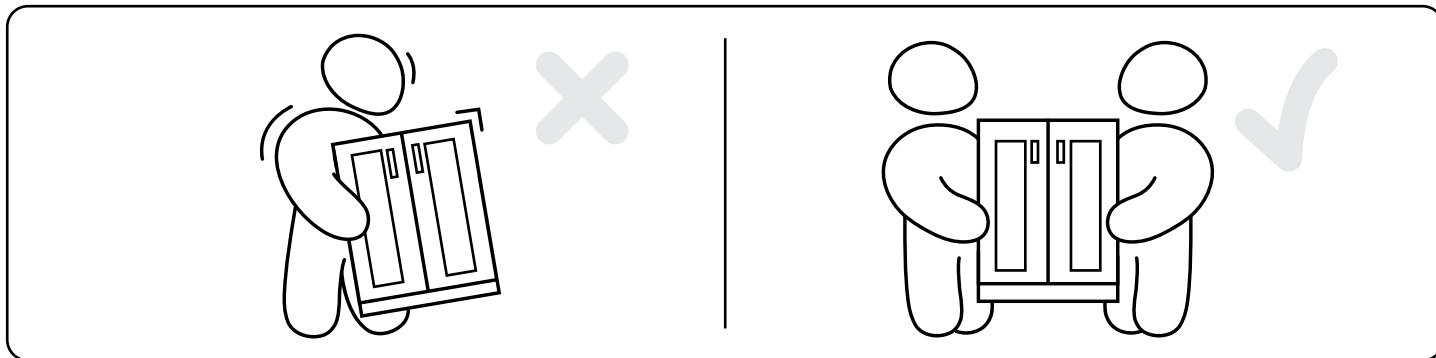
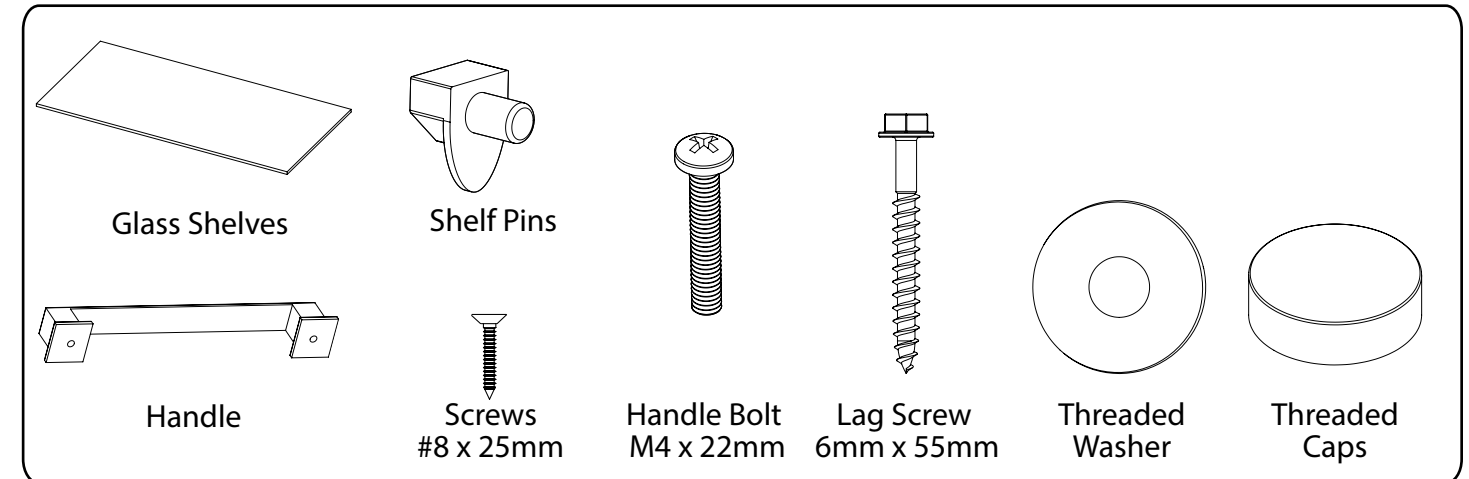

Tools Needed

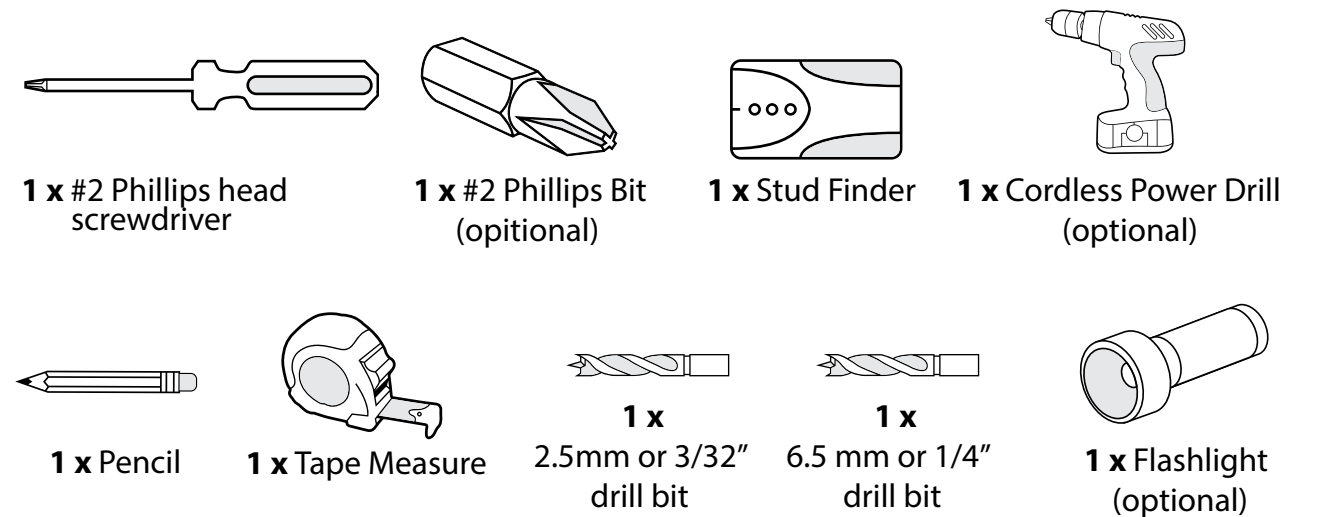

Installing the Handles

Note:
Cabinets come with handles installed on inside of drawers/doors.

1 Parts Needed.

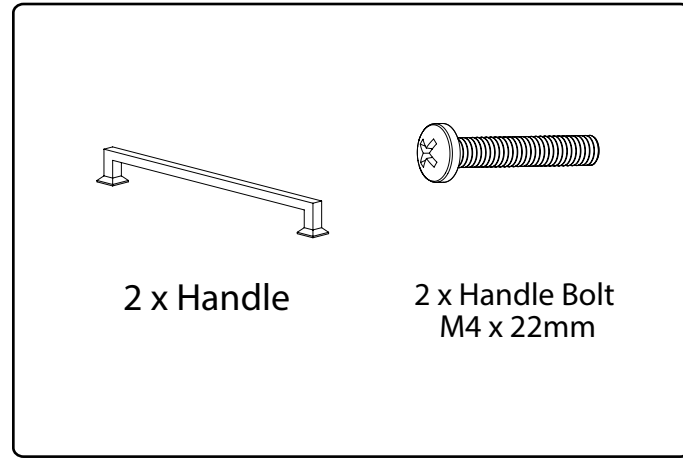

2 Align handle to holes on doors or drawers.

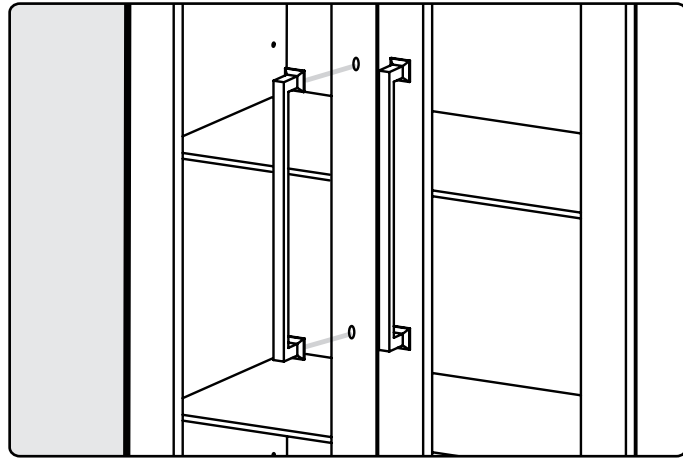

3 Screw in bolts.

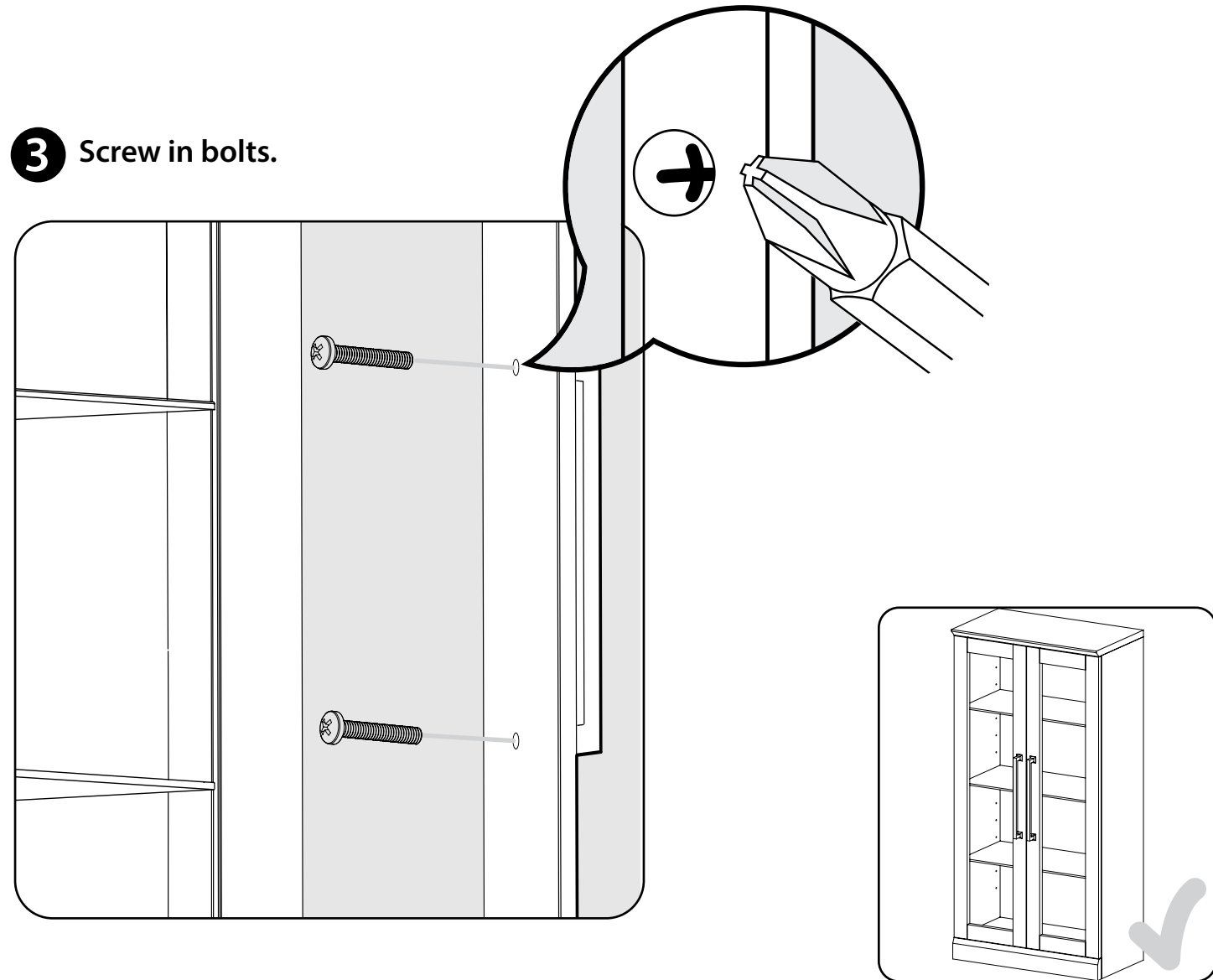

Inserting Glass Shelves

1 Open cabinet doors. Attach shelf clips to desired height.

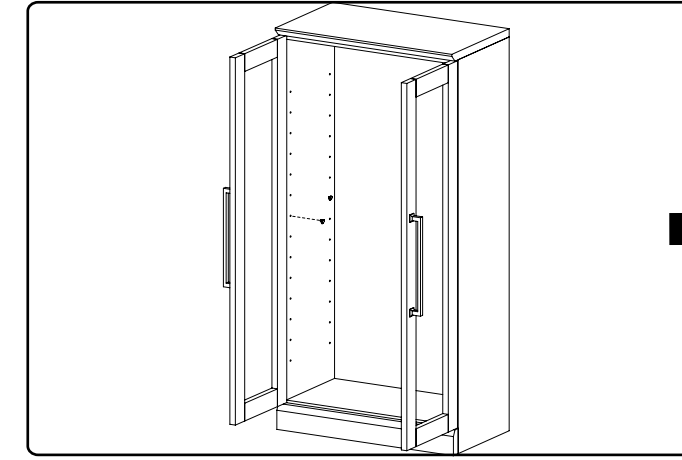

2 Ensure clips are at level height.

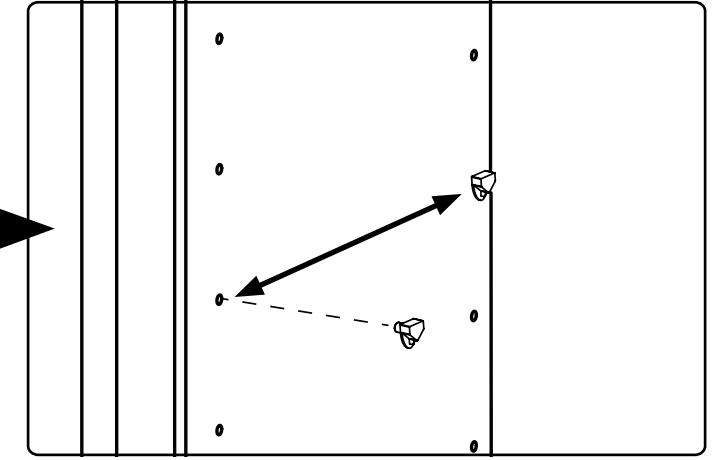

3 Insert glass shelf at a slight angle.

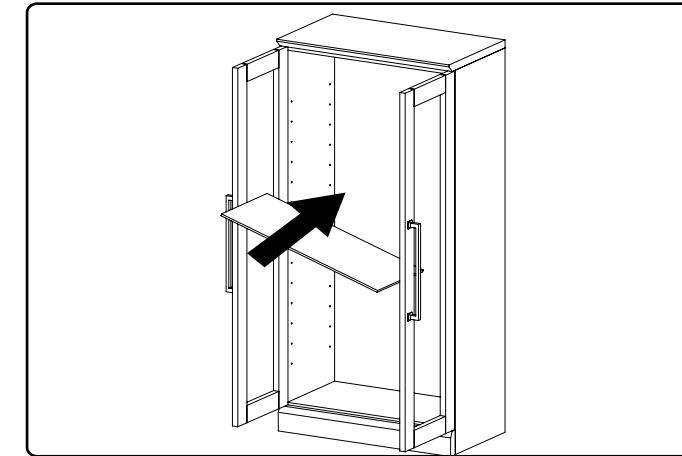

4 Position over shelf supports.

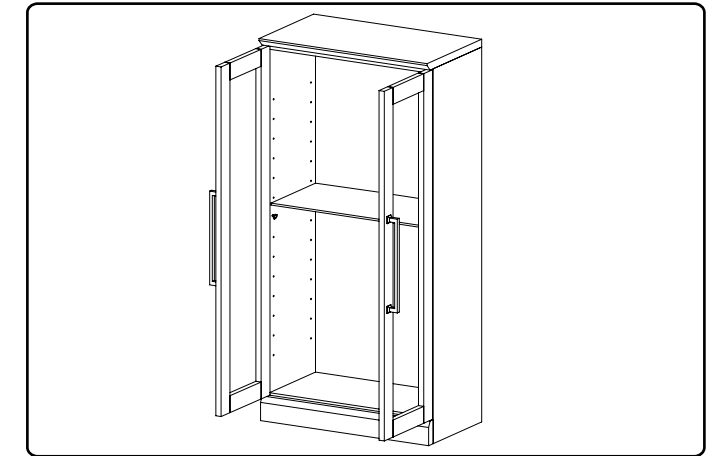

5 Lower shelf down onto shelf supports.

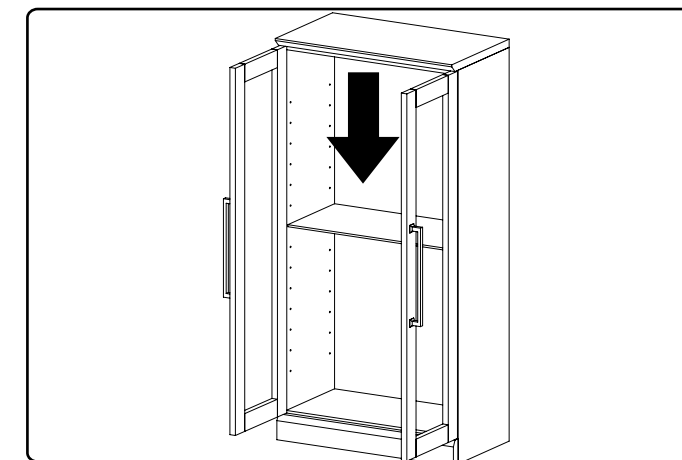

6 Repeat steps 1-4 for all shelves.

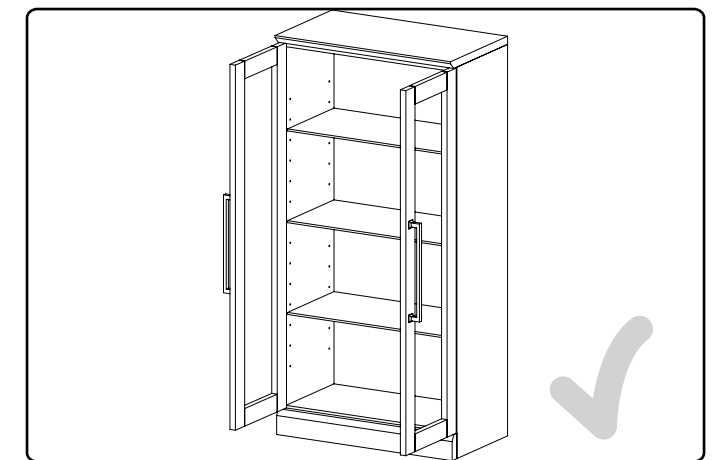

Mounting Cabinets

7 Use stud finder to locate the studs and mark the wall with a pencil.

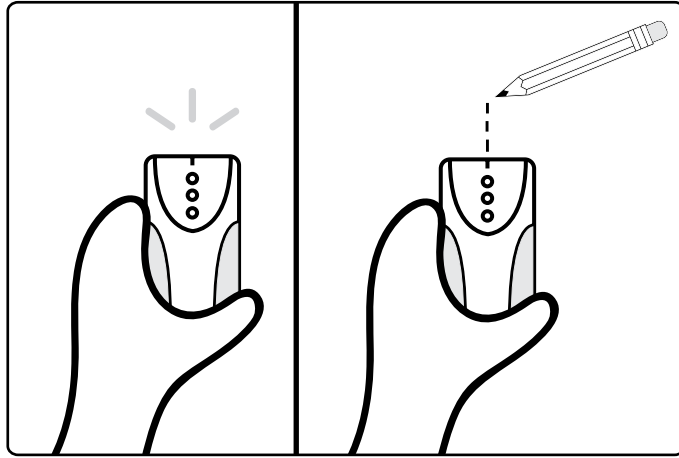

8 Gather parts.

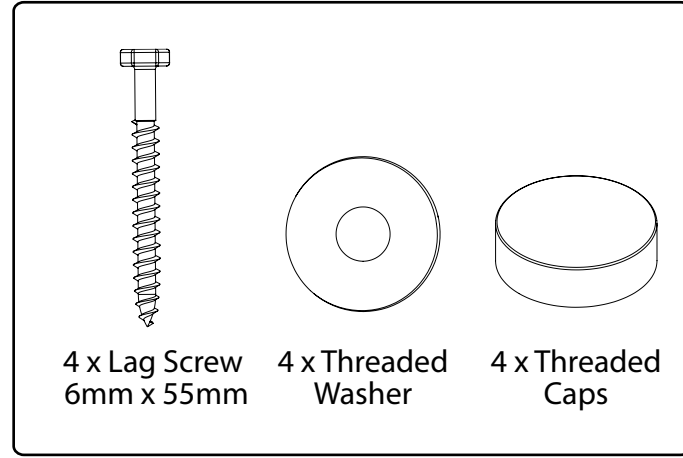

9 Near the top of the cabinet, drill 1/4" holes through the back of the cabinet that are in line with marked studs. Repeat for drilling two holes near the bottom of the cabinet.

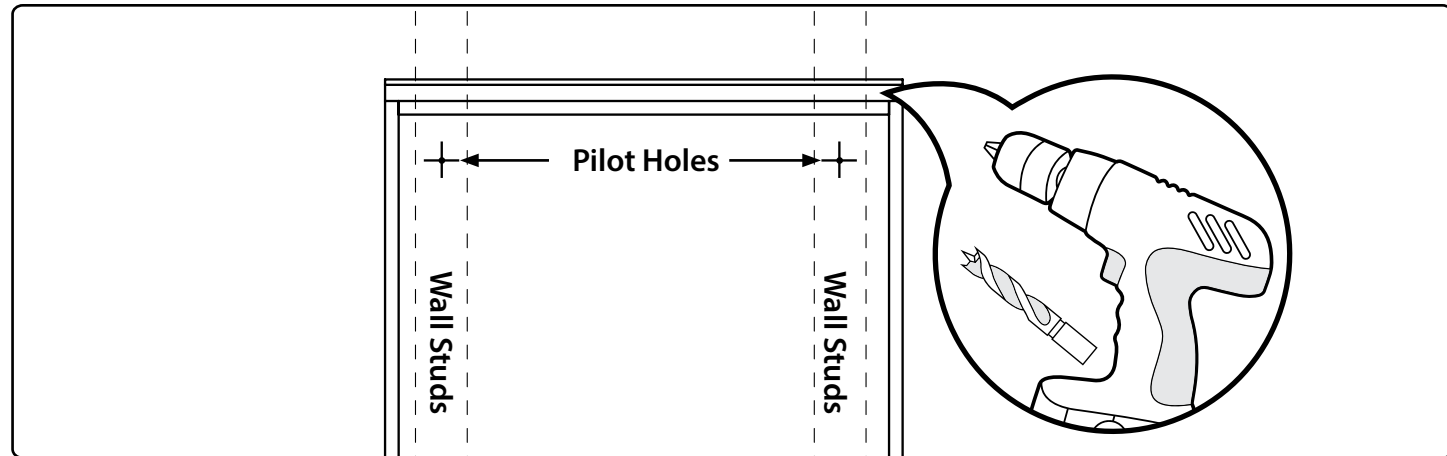

10 Place cabinet flush against wall and attach using screws and washers.

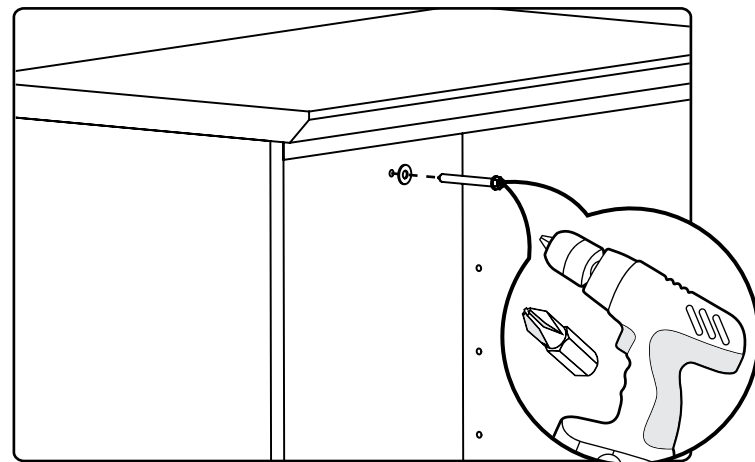

11 Use threaded caps to cover screws.

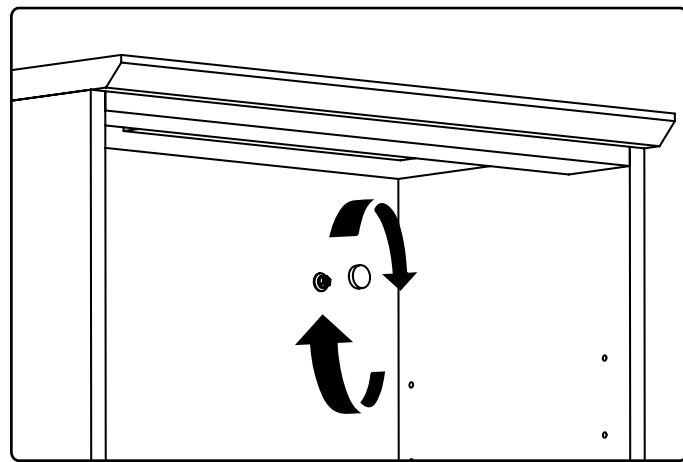

Fastening Cabinets

Note:
All shelves must be removed prior to fastening cabinets together.

12 Parts Needed.

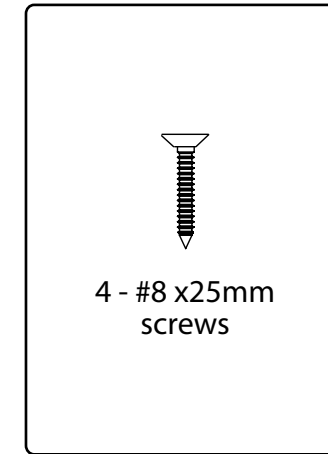

13 Drill 3/32" pilot holes on interior wall of cabinet being fastened.

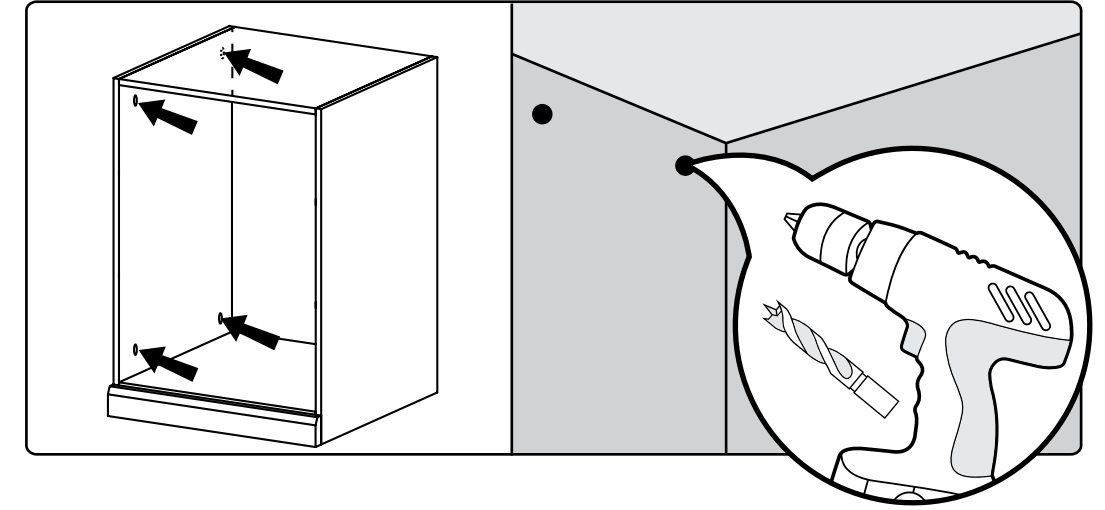

14 Using pilot hole as guides, screw into second cabinet. Do Not Over-tighten screws and Punch through other side!

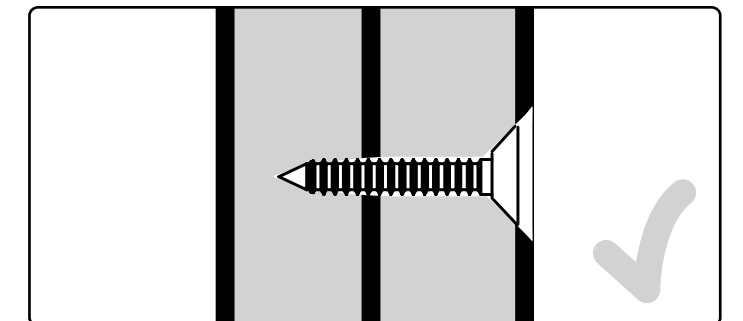
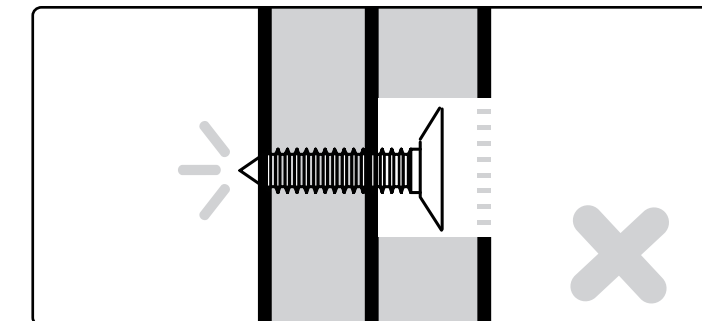
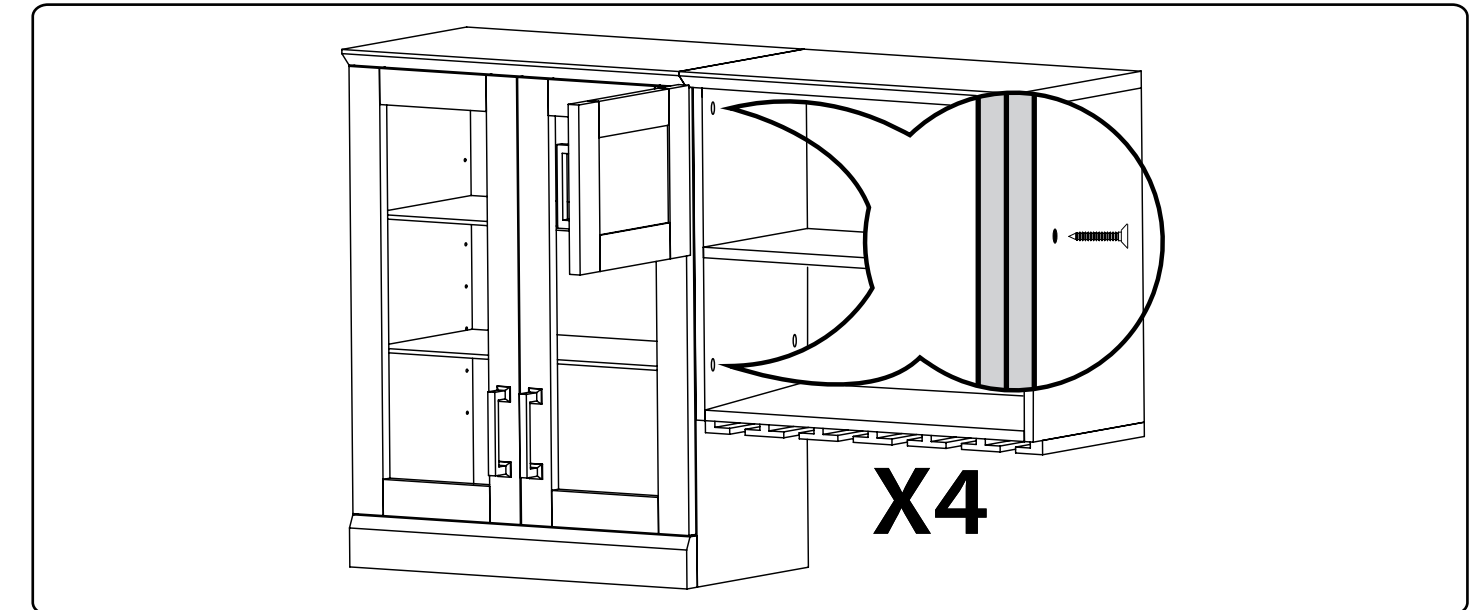

Adjusting The Door Hinges

Using a Philips screwdriver, the doors can be adjusted:
Left, right, forwards and backwards.

15 To adjust the doors left or right, turn the screw (A) clockwise or counterclockwise.

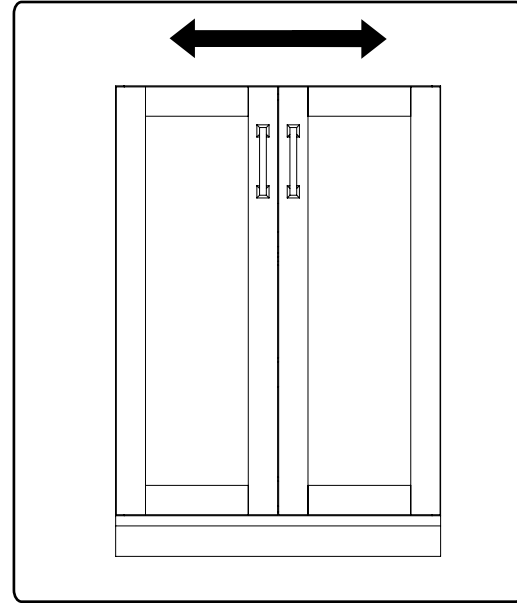
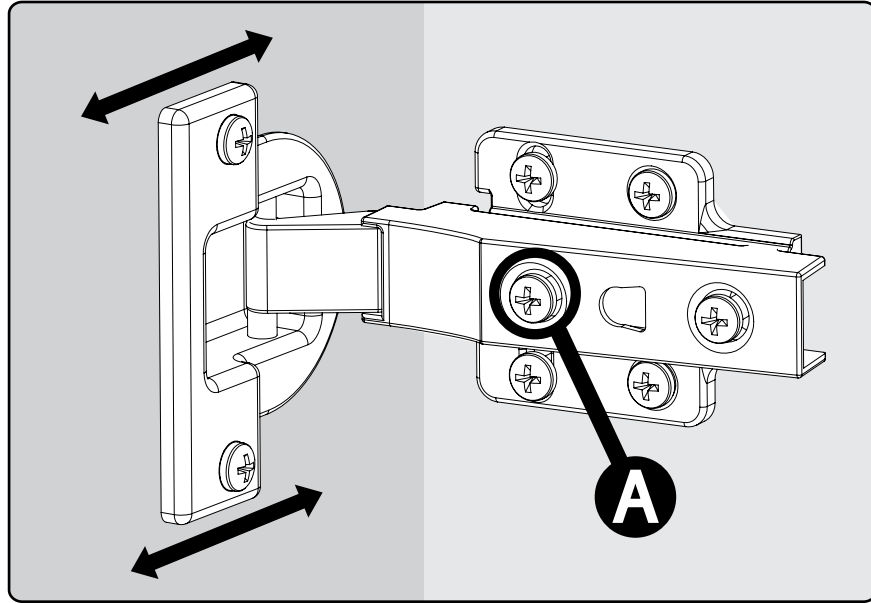

16 To adjust the gap between the doors and frame, turn the screw (B) clockwise or counterclockwise.

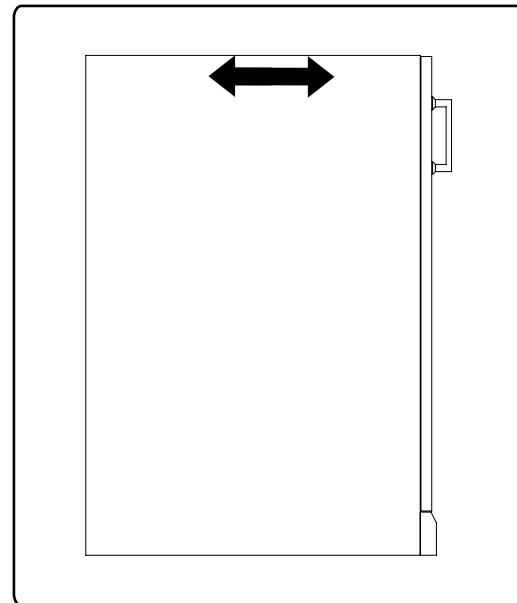
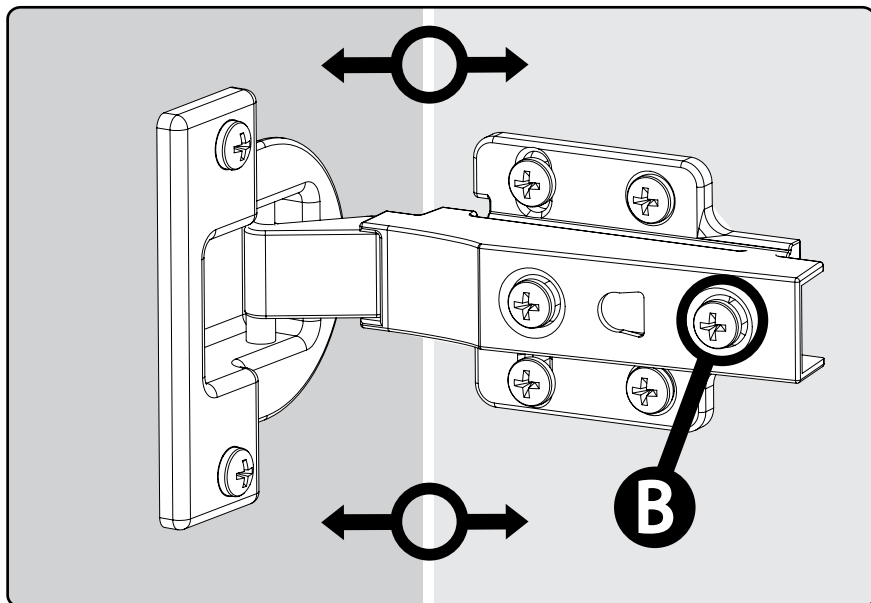

Thank you for purchasing a NewAge Product!

Please give us a call or visit online if you have any questions.

Call 1.877.306.8930; for UK 0800.031.4069; e-mail at info@newageproducts.com

LED Light Guide

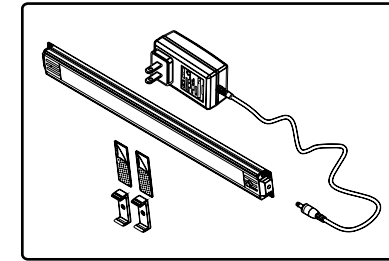

LED Light with power Adapter
SKU# 60836/60838

The adapter kit is used to connect to the electrical outlet, and contains the power on/off switch for the LED lights. It is used when one single light unit is needed or as the first light used when linking multiple light units together. It controls on/off power for all light units linked to it. Includes adapter, LED light, plastic clips, and double sided tape.

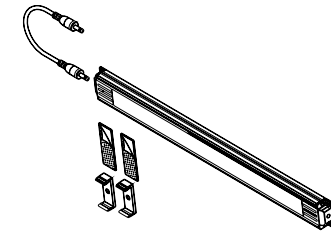

LED Light with Connector wire
SKU# 60837/60839

The connector kit is used when additional light units (up to 4) want to be linked together. It works in conjunction with and is controlled by the LED light with power adapter unit. Includes double sided tape and plastic clips.

How to connect the LED Lights

For LED Lights to work correctly, the adapter cable (A) must connect to end with on/off switch, for LED Light to be operational. Use connector cords (B) to connect additional lights. Up to 4 LED lights can be connected to one Power adapter cord (A).

NOTE: For Wall Switch Operation

If you are using a switch controlled power outlet to operate the LED Lights, the power adapter cord needs to plug into the end opposite the ON/OFF switch end.

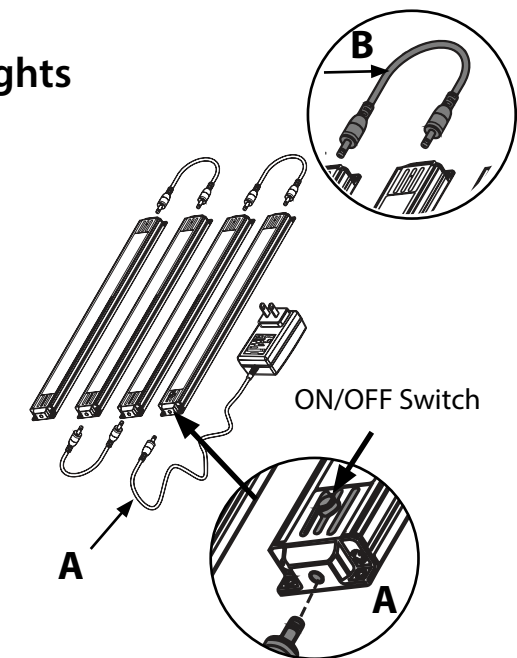

Installing LED Lights for Wall Cabinets

- 1** Method 1. Using double sided tape provided. Attach double sided tape to back of LED light bar. Peel backing off.

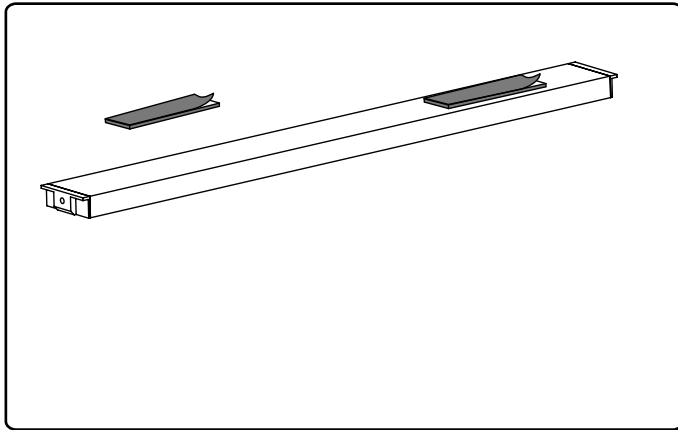

- 2** Center and press firmly 5.5", in from walls and 7.5", in from back wall.

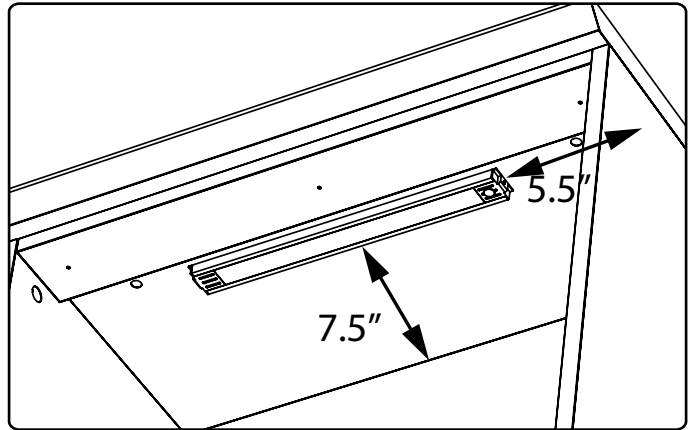

- 3** Feed connector cable through pre-drilled holes on tops of cabinet and connect at ends of LED light strips.

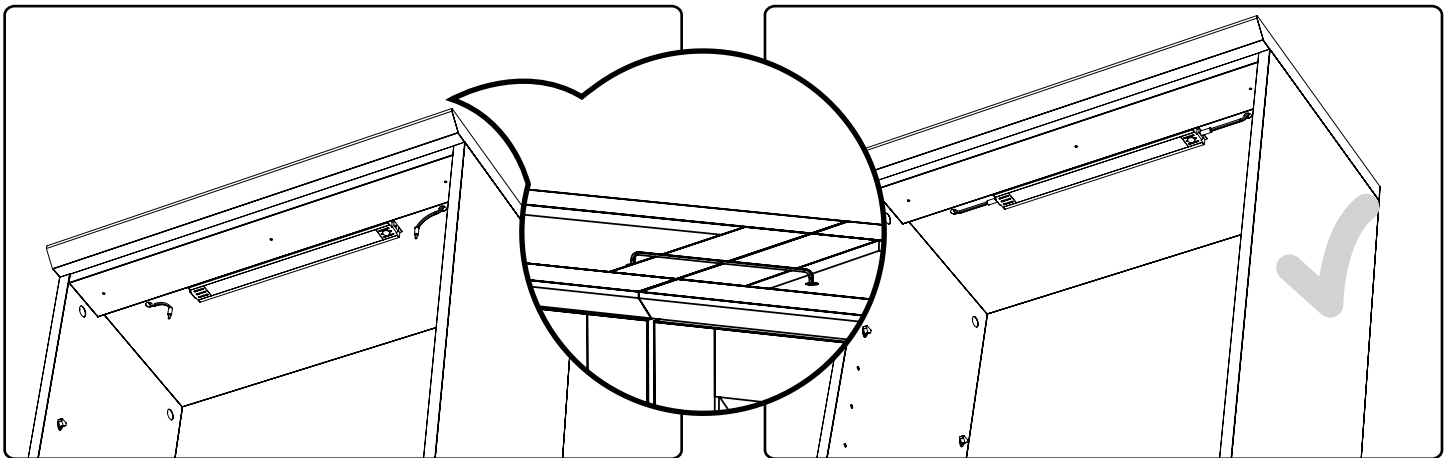

Installing LED Lights for Wall Cabinets cont.

Method 2. Using clips provided.

- 4** Predrill 3/32 holes, 8.5" in from side walls and 8" in from back wall. Attach clips using screws included in packaging.

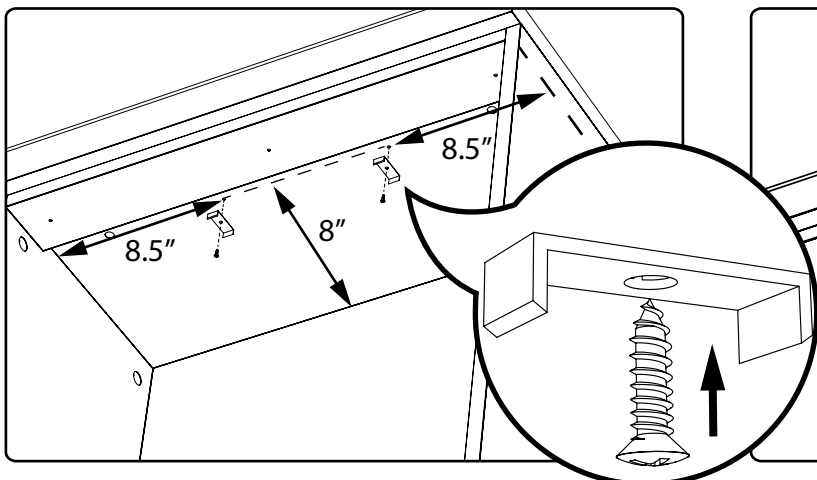

- 5** Clip LED light strip into clips. Return to Step 4. for connecting light string.

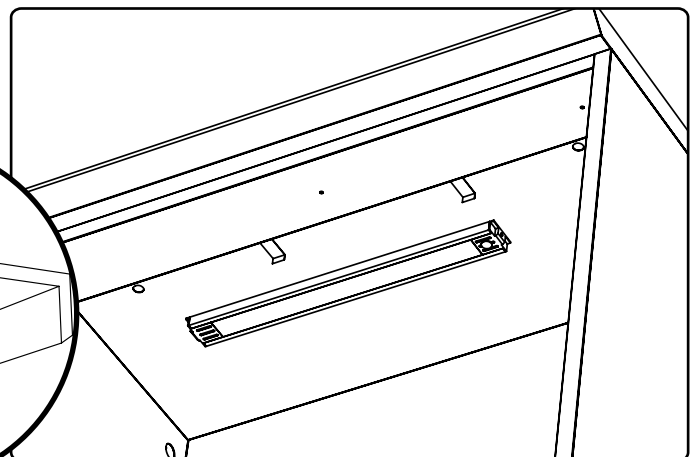

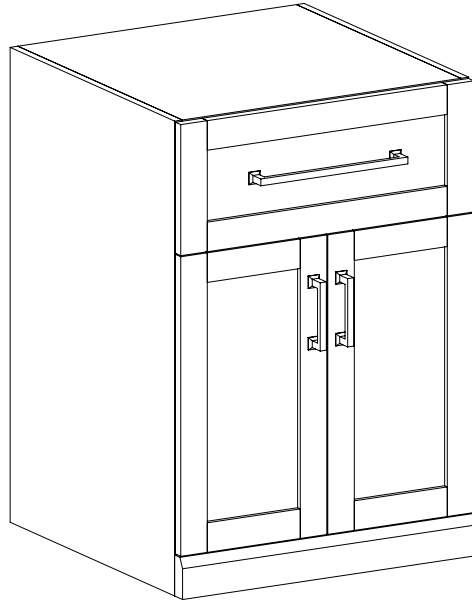

HOME BAR SERIES SPLIT CABINET



Warning: Excessive weight hazard!

Use two or more people to move, assemble, or install cabinets and locker to avoid back injury. Do not leave children unattended near cabinets. High risk of tipping if cabinets are installed incorrectly: securely attach cabinets to the wall to avoid serious injury. For assistance, call 1.877.306.8930; for U.K 0800.031.4069; e-mail at info@newageproducts.com.

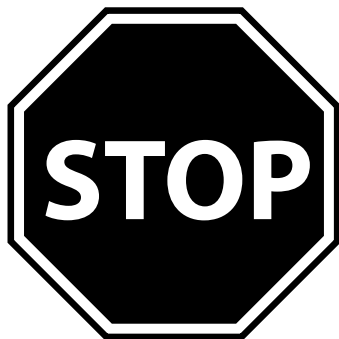

ATTENTION: Is your cabinet damaged? Need help or spare parts? For fastest service, contact NewAge Products at 1-877-306-8930; or support@newageproducts.com. Do not return to the retailer.

Weight Capacity

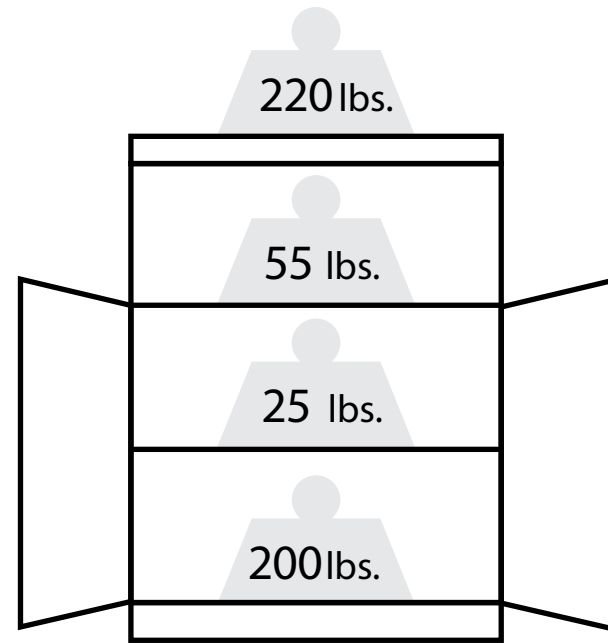

Split Base Cabinet
Max 500 lbs.

Countertops

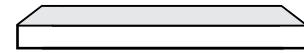

48" Countertop. Fits over 2 Cabinets

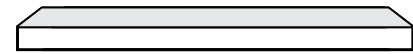

72" Countertop. Fits over 3 Cabinets

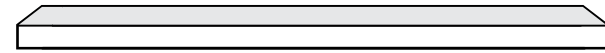

96" Countertop. Covers over 4 Cabinets

Unpacking

- Begin by placing the package on a covered flat surface.
- Remove all cardboard, foam packaging material and clear plastic bags.
- Dispose / recycle all packaging materials.
- Verify all the contents in the box and gather the required tools. See "Parts" and "Tools Needed" in the list below.

Parts Supplied	Split Cabinet
Door Handles	2
Drawer Handles	1
Handle Bolts for Doors (M4x22mm)	4
Handle Bolts for Drawers (M4x30mm)	2
#8 x 25mm Screws	6
Shelf	1
Shelf Clips	6



Door Handle

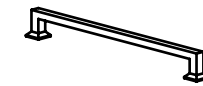

Drawer Handle

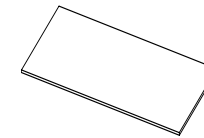

Shelf

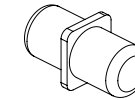

Shelf Pins

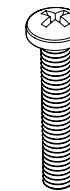

Door Handle Bolt
M4 x 22mm

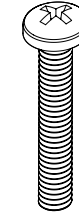

Drawer Handle Bolt
M4 x 30mm

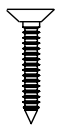

Screws
#8 x 25mm

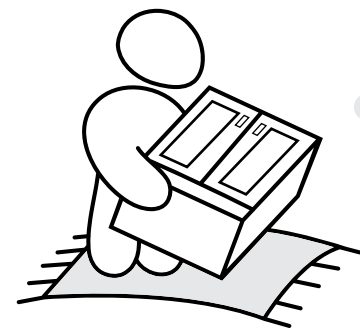
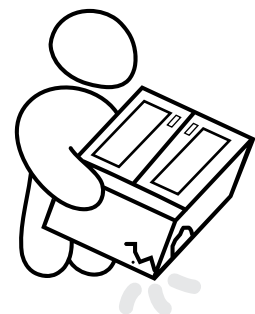
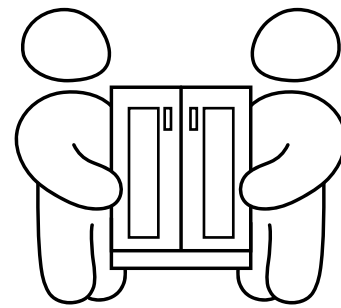
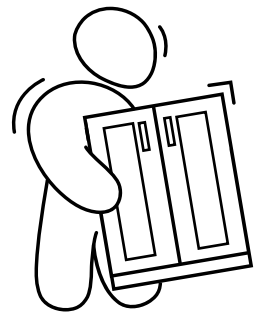

Tools Needed

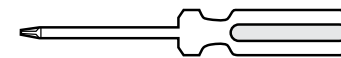

1 x #2 Phillips head
screwdriver

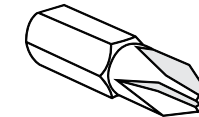

1 x #2 Phillips Bit
(optional)



1 x Cordless Power Drill
(optional)

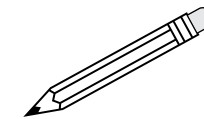

1 x Pencil

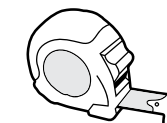

1 x Tape Measure



1 x Drill Bit
2.5mm or 3/32"

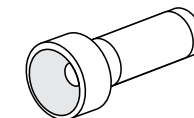

1 x Flashlight
(optional)

Installing Drawer Handle

Note:
Cabinets come with handles installed on inside of drawers/doors.

1 Parts Needed.

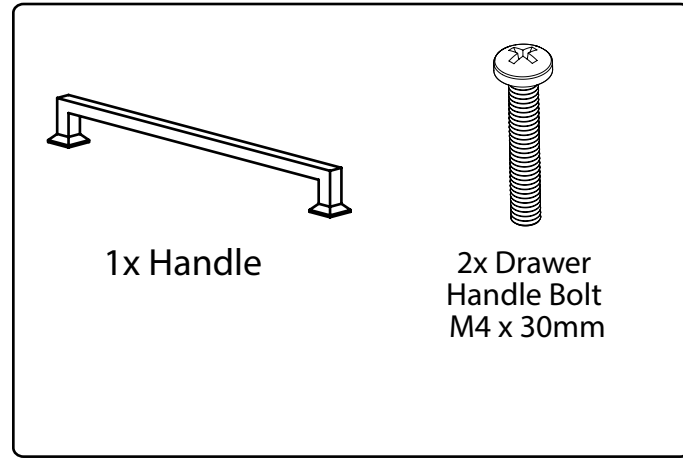

2 Align handle to holes on doors or drawers.

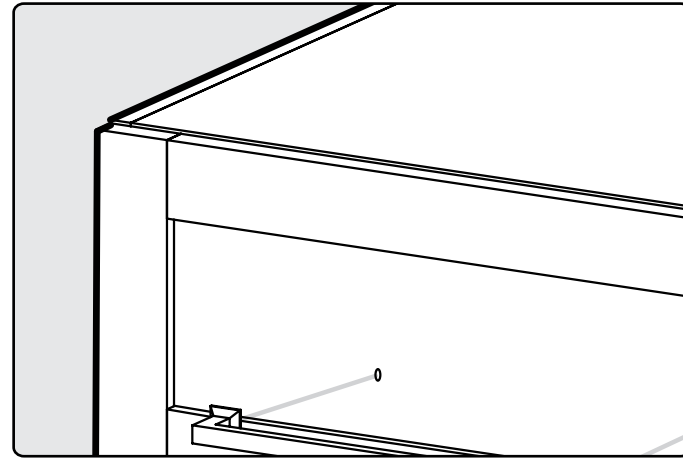

3 Screw in bolts.

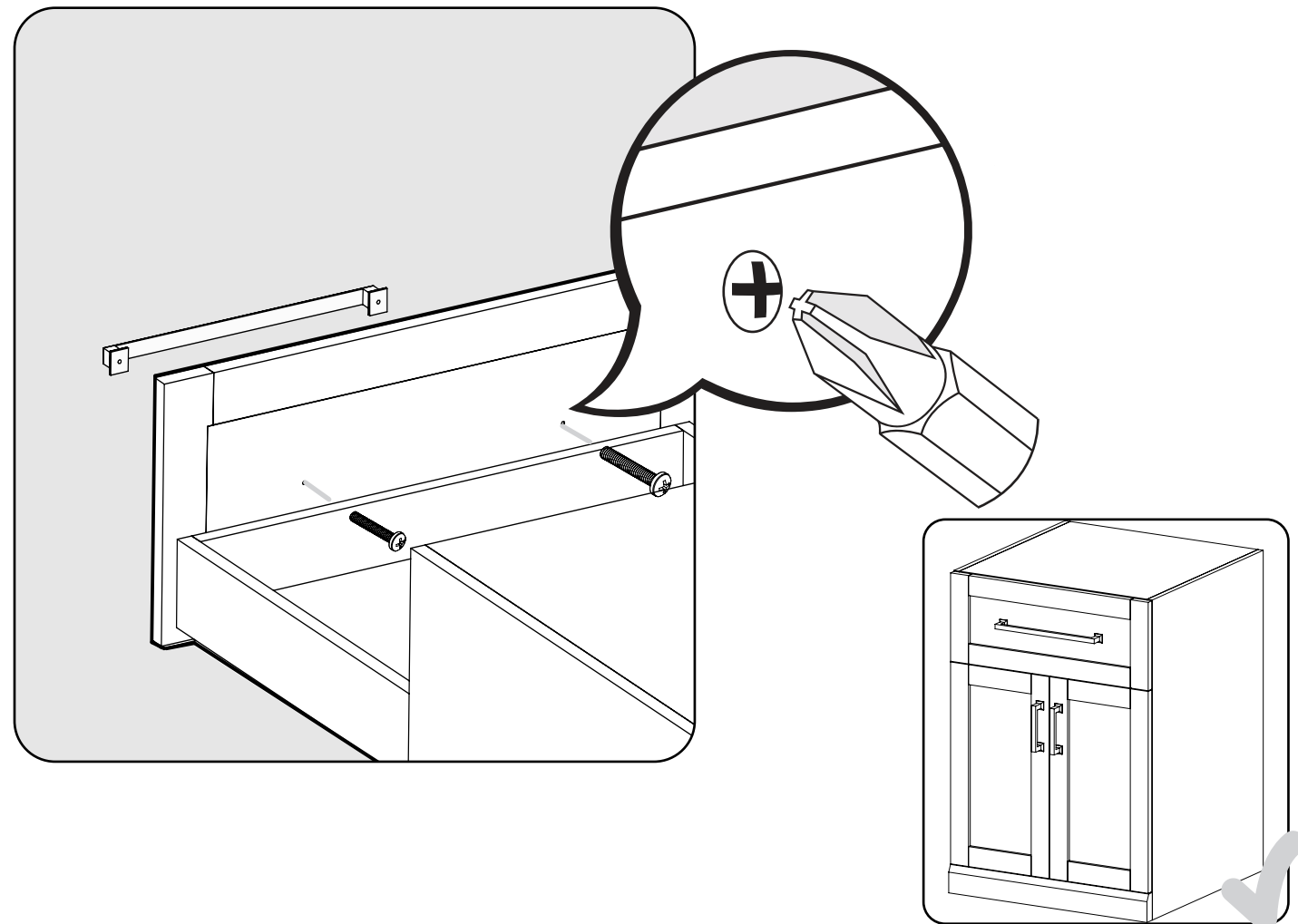

Installing the Handles

4 Parts Needed.

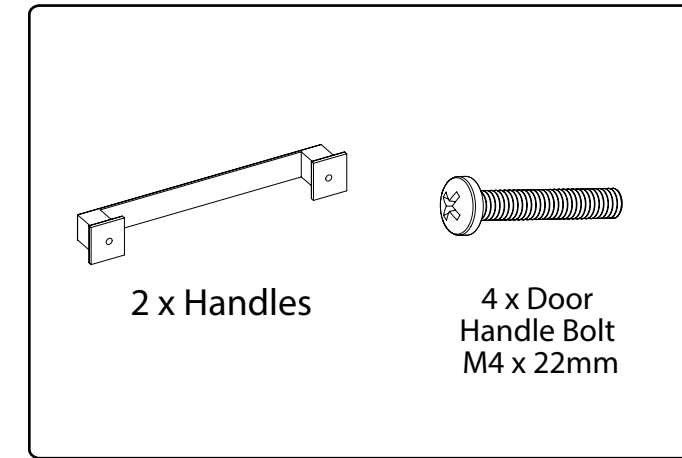

5 Align handle to holes on doors or drawers.

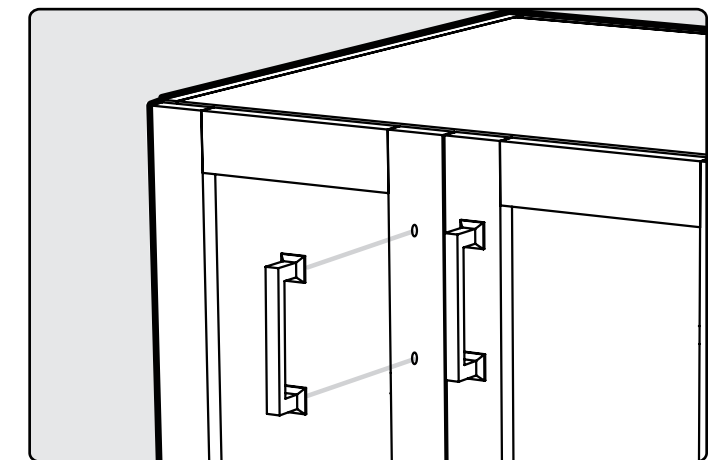

6 Screw in bolts.

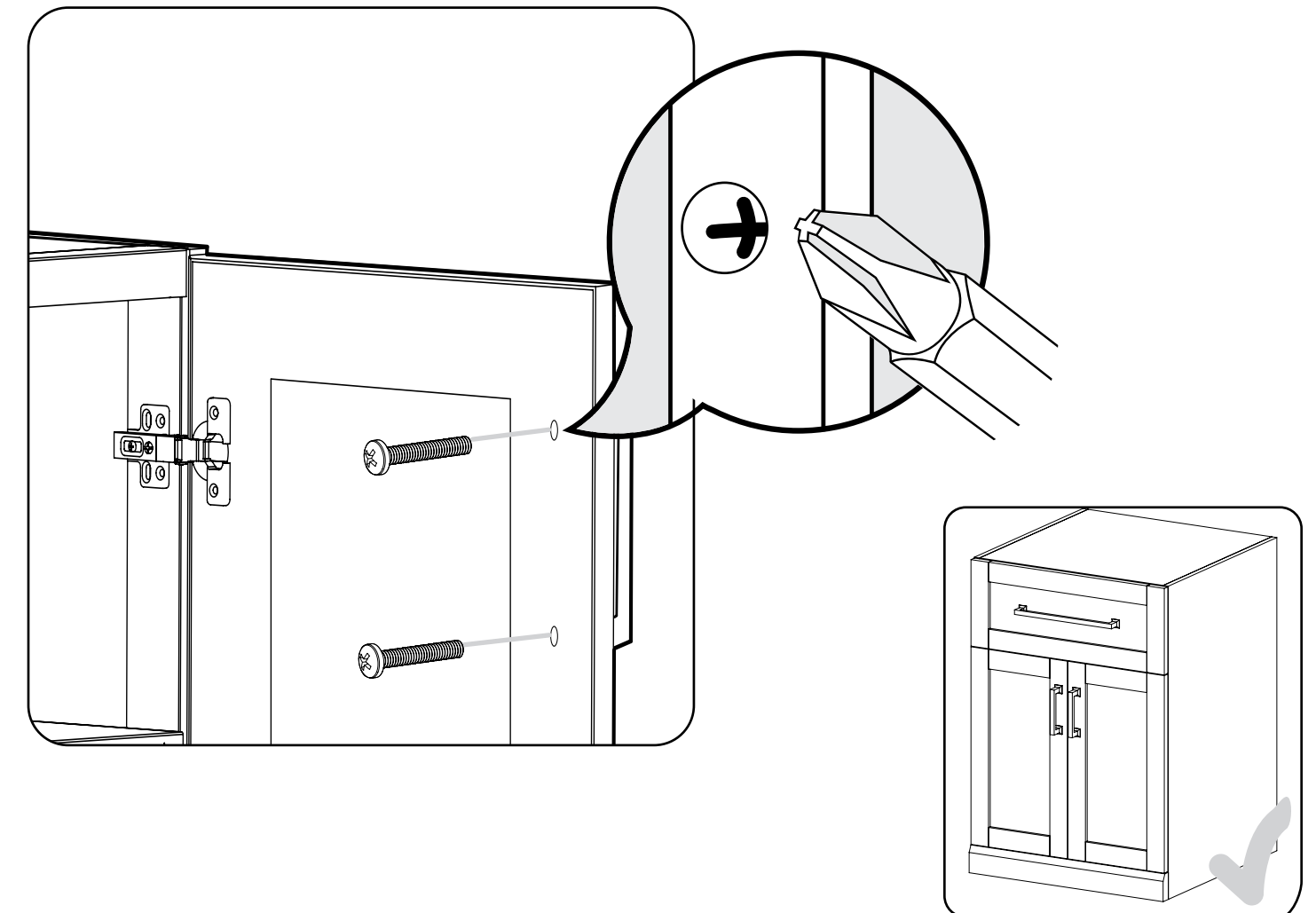

Inserting Shelf

1 Open cabinet doors. Attach shelf clips to desired height.

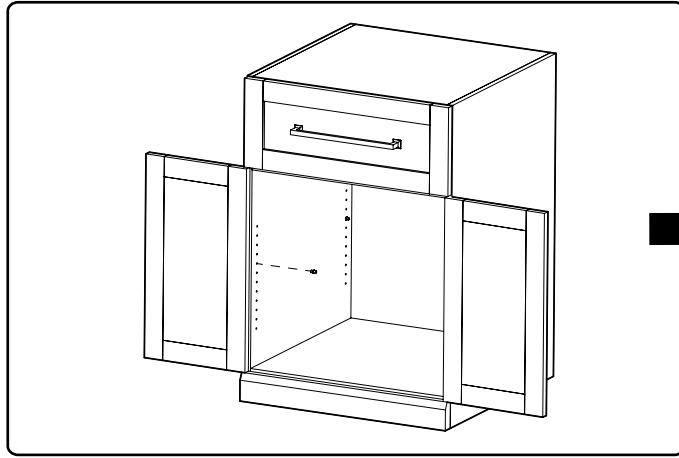

2 Ensure clips are at level height.

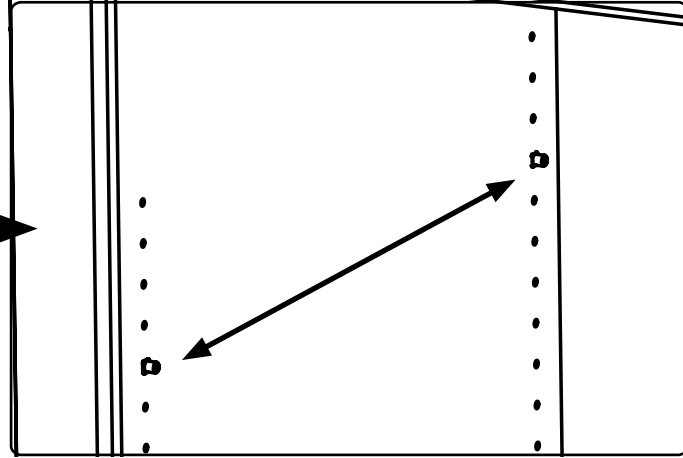

3 Insert shelf at a slight angle.

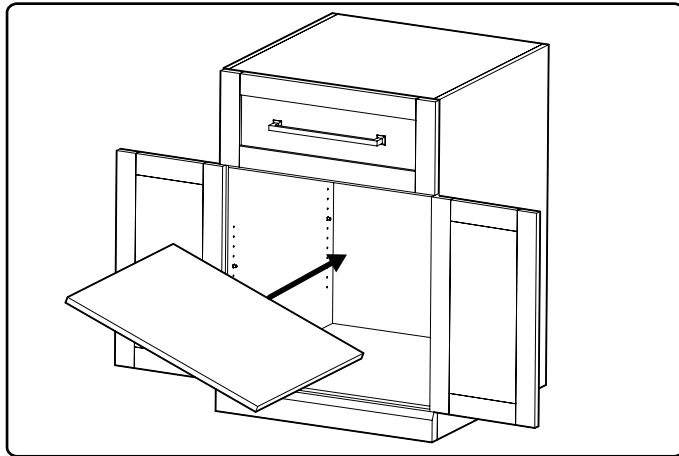

4 Position over shelf supports. Lower shelf down onto shelf supports.

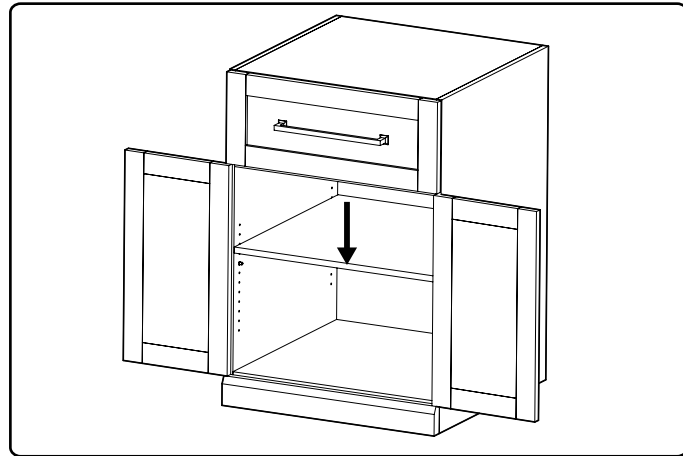

5

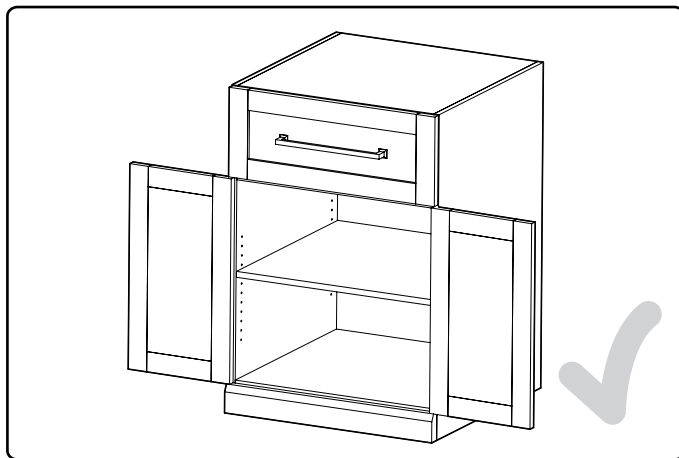

Removing Drawer

7 Extend drawer fully.

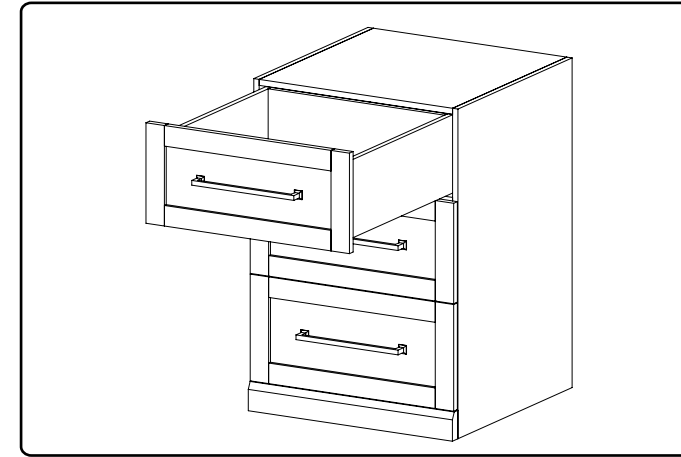

8 Press plastic triggers on underside of drawer according to arrows in image.

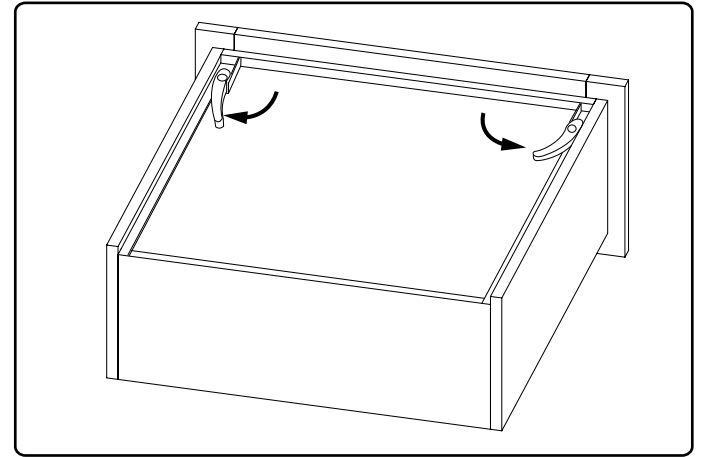

9 Tilt and remove shelf rack.

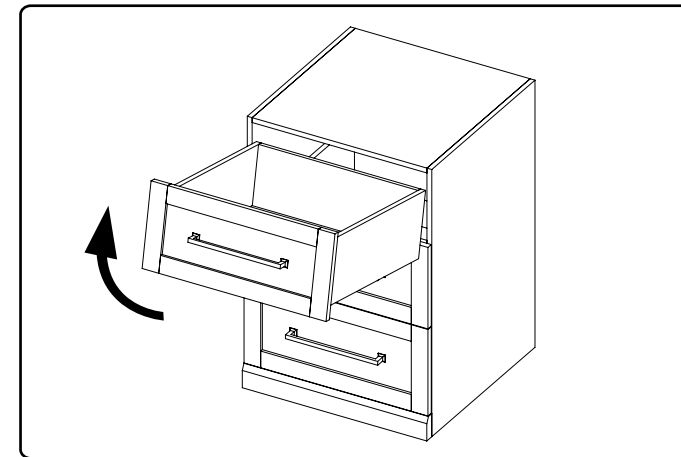

Inserting Drawer

10 Partially extend drawer slides.

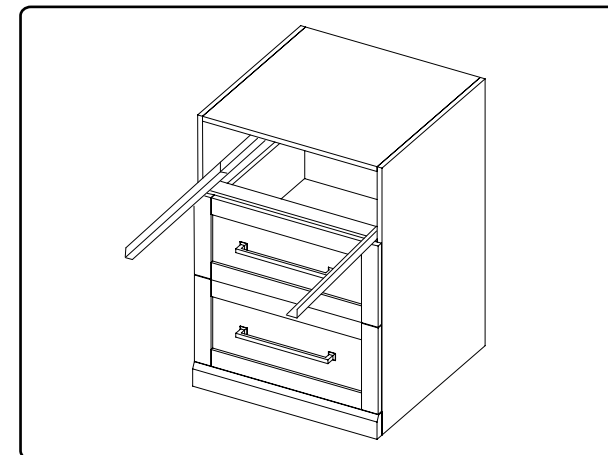

11 Put drawer on slides and slide each drawer slide forward until you hear a click sound.

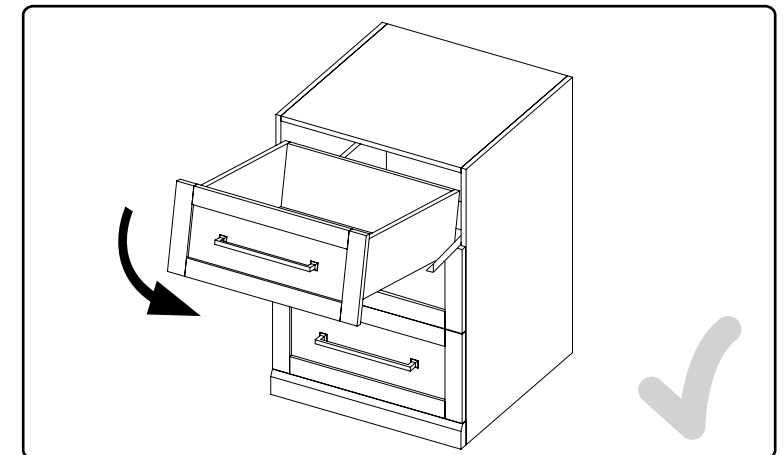

Fastening Cabinets

Note:
All shelves and drawers must be removed prior to fastening cabinets together.

- 12** Parts Needed. **13** Drill 3/32 pilot holes on interior wall of cabinet being fastened.

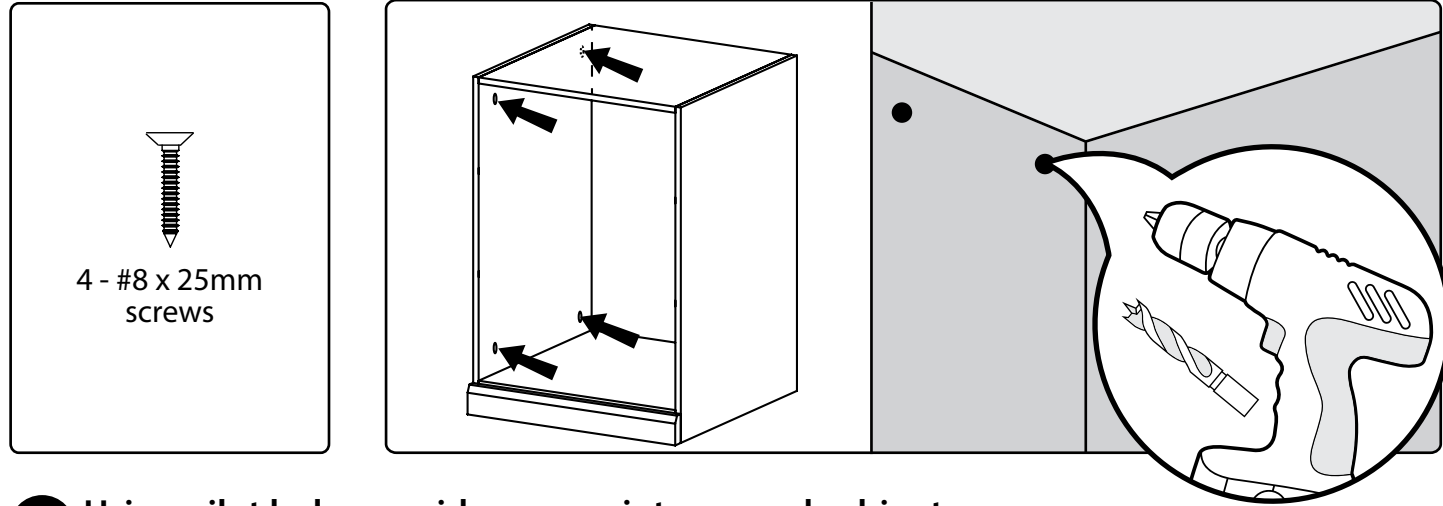

- 14** Using pilot hole as guides, screw into second cabinet. Do not over-tighten screws and punch through other side!

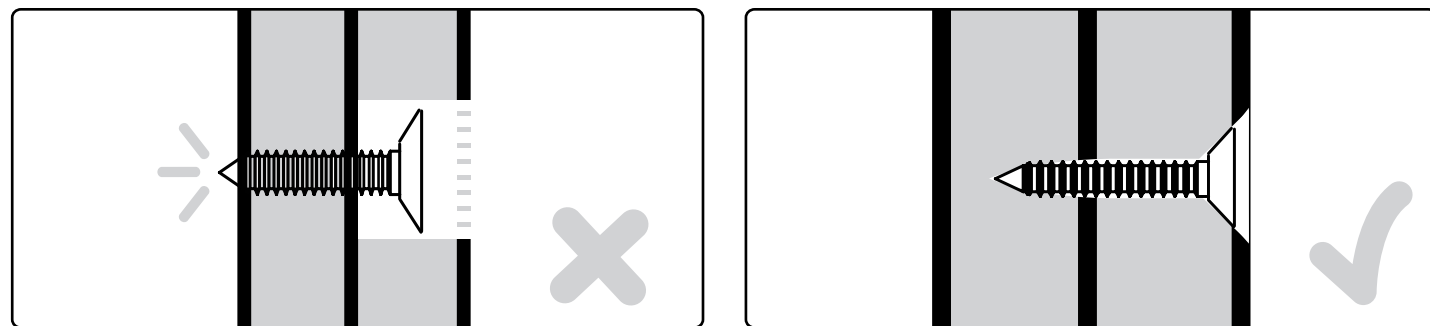
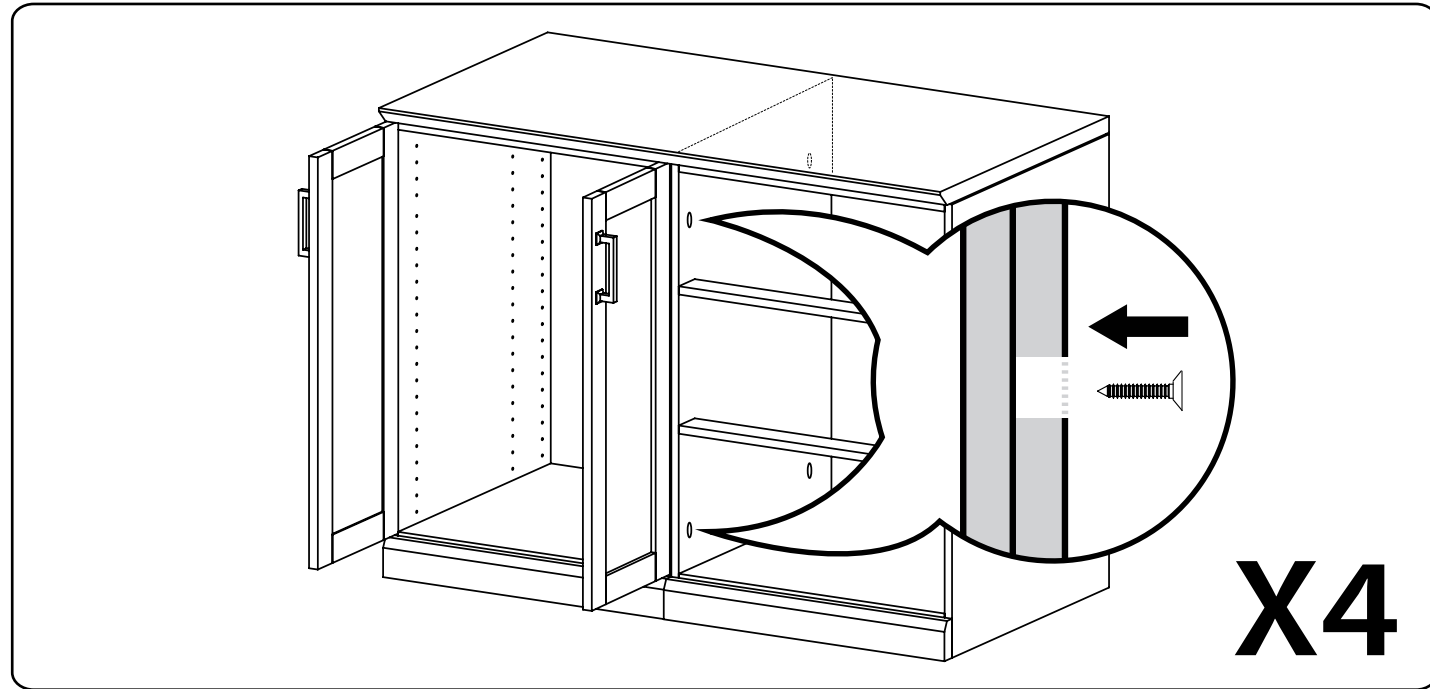

Mounting the Worktop

- 15** Place worktop over cabinets and lower onto cabinets.

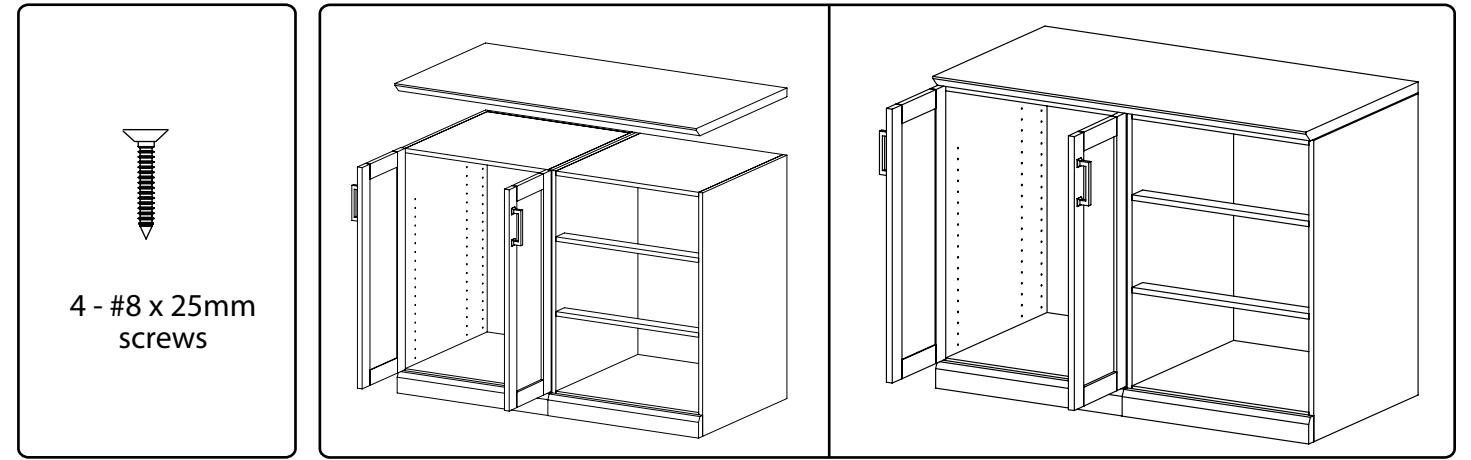

- 16** Drill 4, 3/32" pilot holes on interior roof of cabinet.

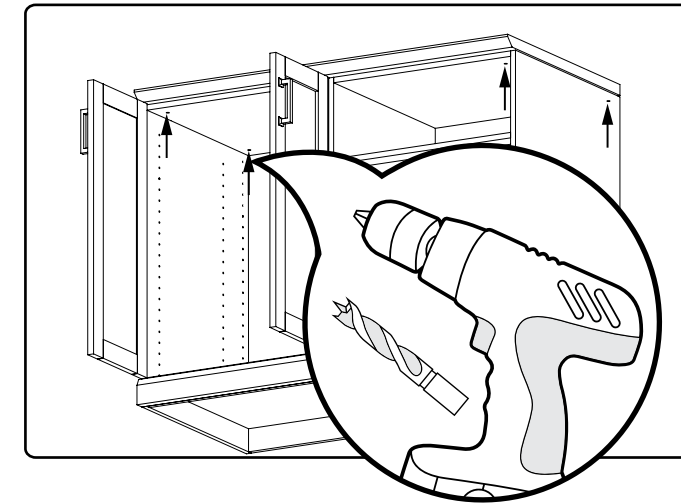

- 17** Tighten screws to secure cabinets.

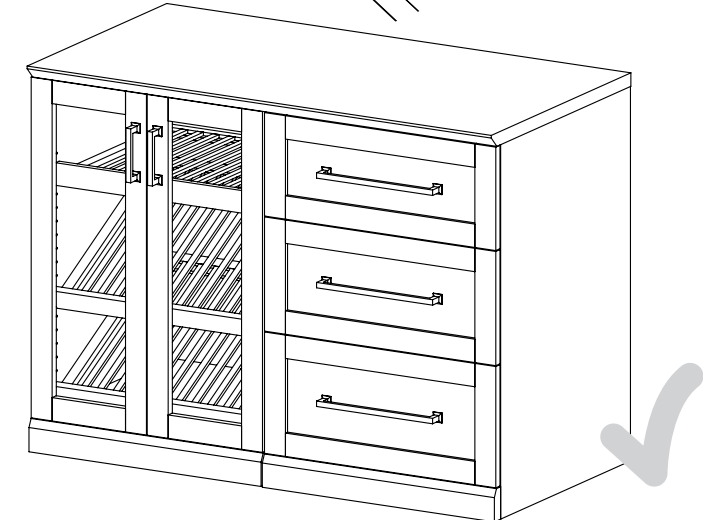
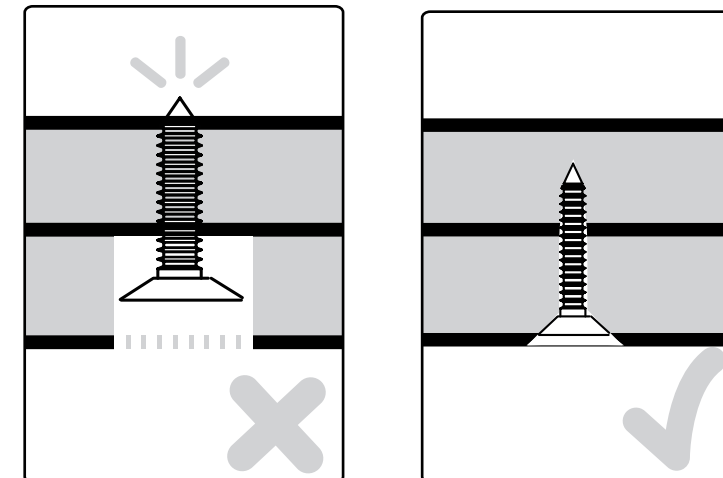
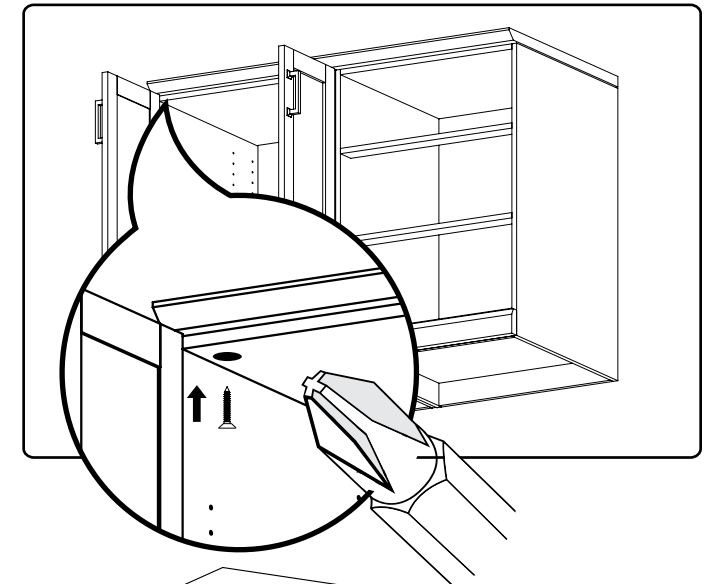

Adjusting The Door Hinges

Using a Philips screwdriver, the doors can be adjusted:
Left, right, forwards and backwards.

18 To adjust the doors left or right, turn the screw (A) clockwise or counterclockwise.

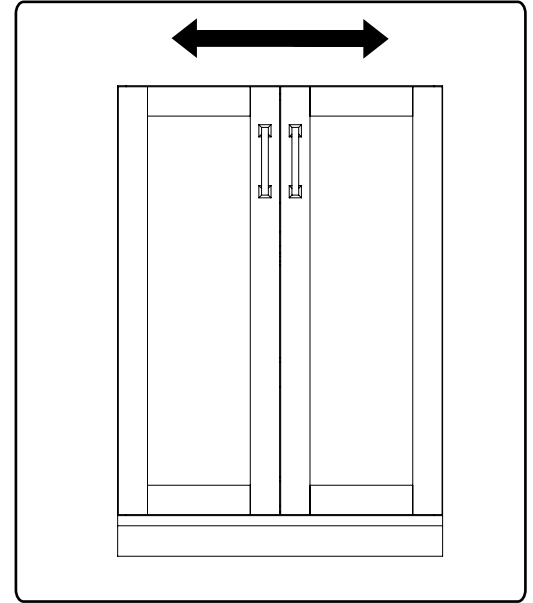
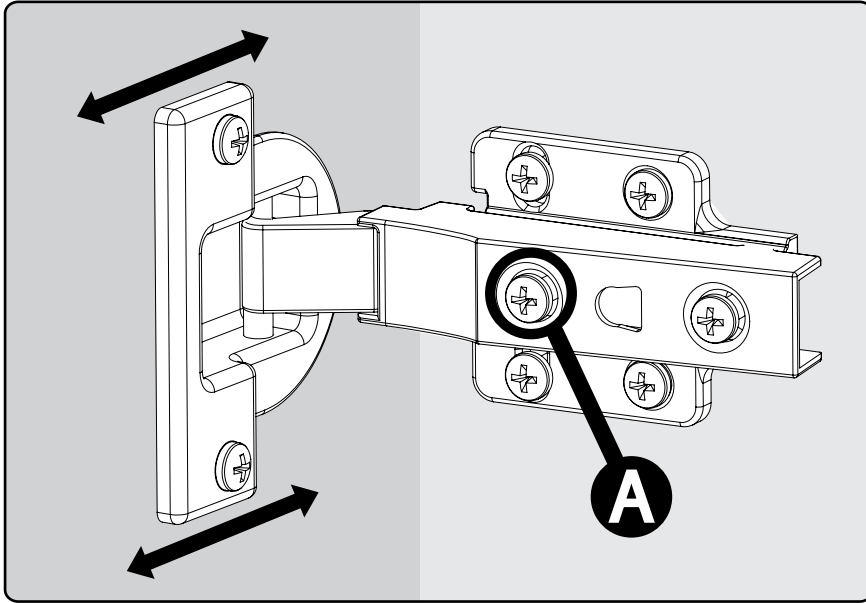

19 To adjust the gap between the doors and frame, turn the screw (B) clockwise or counterclockwise.

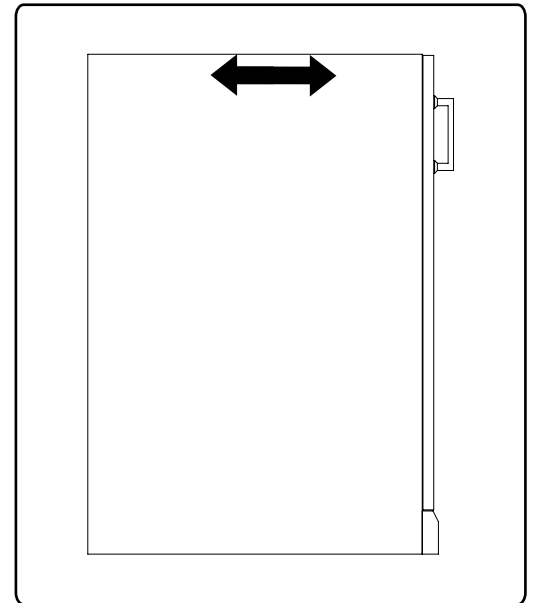
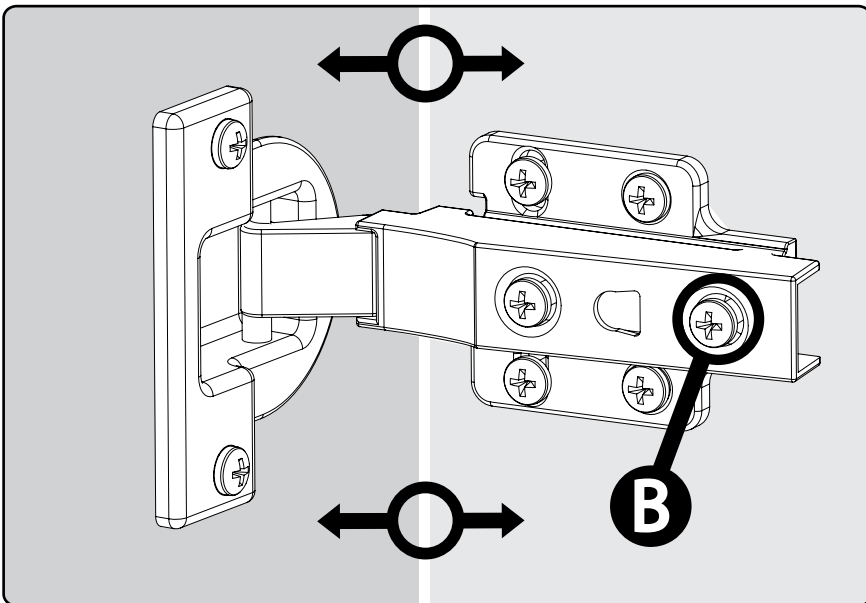

Thank you for purchasing a NewAge Product!

Please give us a call or visit online if you have any questions.

Call 1.877.306.8930; for UK 0800.031.4069; e-mail at info@newageproducts.com

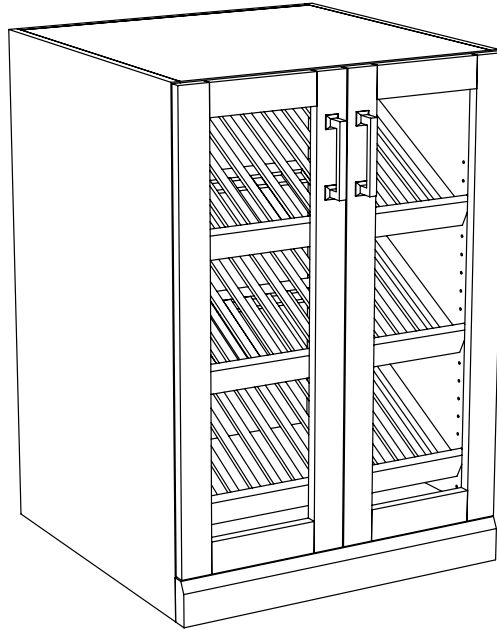

HOME BAR SERIES DISPLAY CABINET

Warning: Excessive weight hazard!



Use two or more people to move, assemble, or install cabinets and locker to avoid back injury. Do not leave children unattended near cabinets. High risk of tipping if cabinets are installed incorrectly: securely attach cabinets to the wall to avoid serious injury. For assistance, call 1.877.306.8930; for U.K 0800.031.4069; e-mail at info@newageproducts.com.

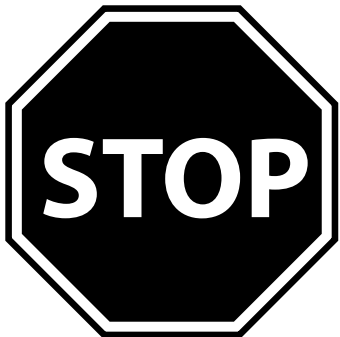

ATTENTION: Is your cabinet damaged? Need help or spare parts? For fastest service, contact NewAge Products at 1-877-306-8930; or support@newageproducts.com. Do not return to the retailer.

Weight Capacity

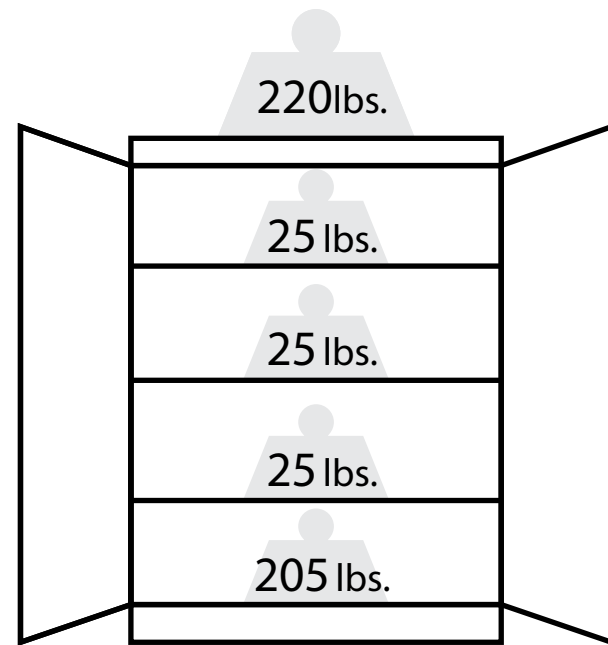

Bottle Display
Base Cabinet
Max 500lbs.

Countertops

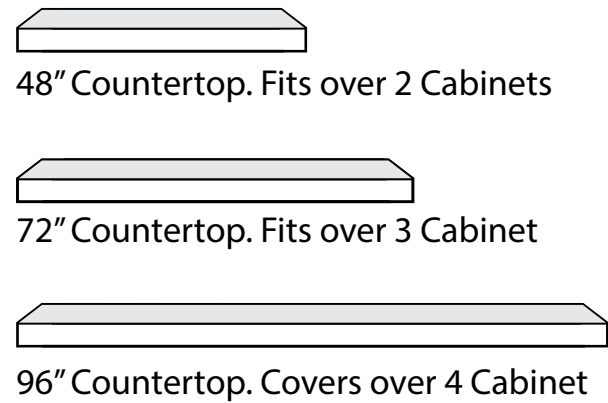

Unpacking

- Begin by placing the package on a covered flat surface.
- Remove all cardboard, foam packaging material and clear plastic bags.
- Dispose / recycle all packaging materials.
- Verify all the contents in the box and gather the required tools. See "Parts" and "Tools Needed" in the list below.

Parts Supplied	Bottle Display Cabinet
Handles	2
Handle Bolts (M4 x 22mm)	4
Adjustable Display Racks	3
Shelf Pins	14
#8 x 25mm Screws	6

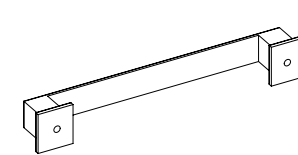

Handle

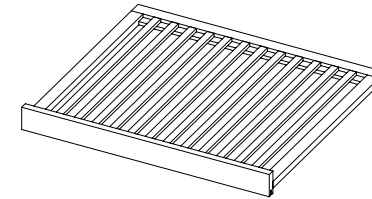

Display Racks

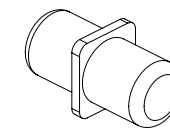

Shelf Pins

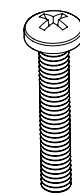

Handle Bolt
M4 x 22mm

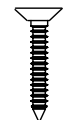

Screws
#8 x 25mm

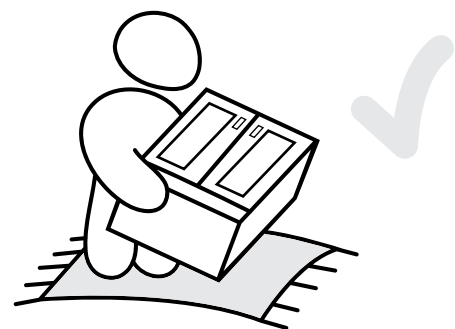
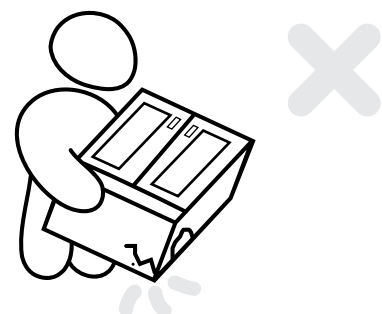
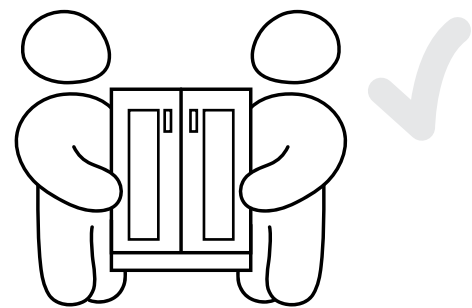
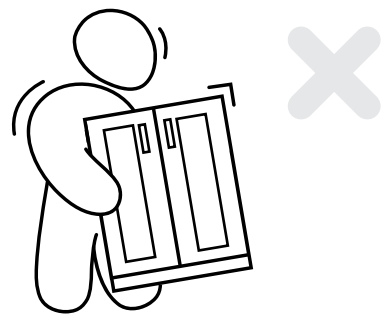

Tools Needed

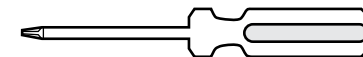

1 x #2 Phillips head
screwdriver

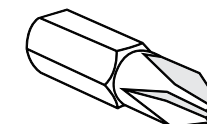

1 x #2 Phillips Bit
(optional)



1 x Cordless Power Drill
(optional)

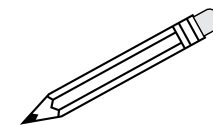

1 x Pencil

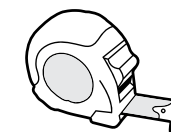

1 x Tape Measure



1 x Drill Bit
2.5mm or 3/32"

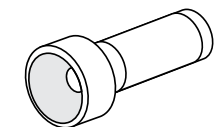

1 x Flashlight
(optional)

Installing the Handles

Note:
Cabinets come with handles installed on inside of drawers/doors.

1 Parts Needed.

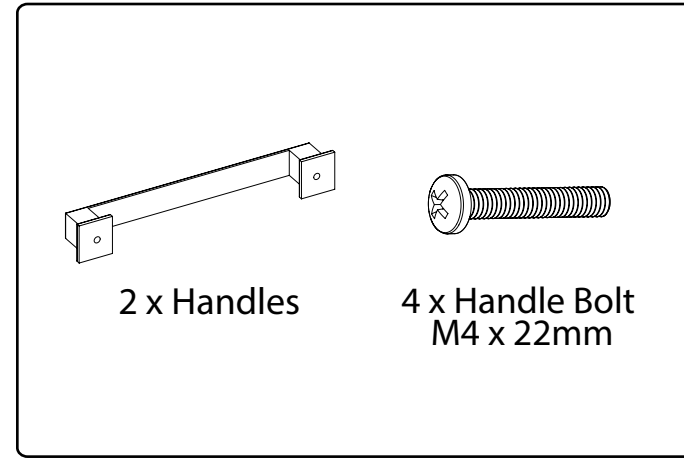

2 Align handle to holes on doors or drawers.

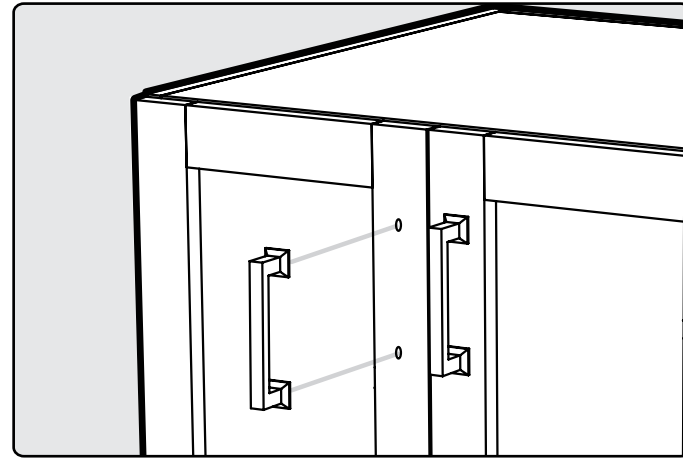

3 Screw in bolts.

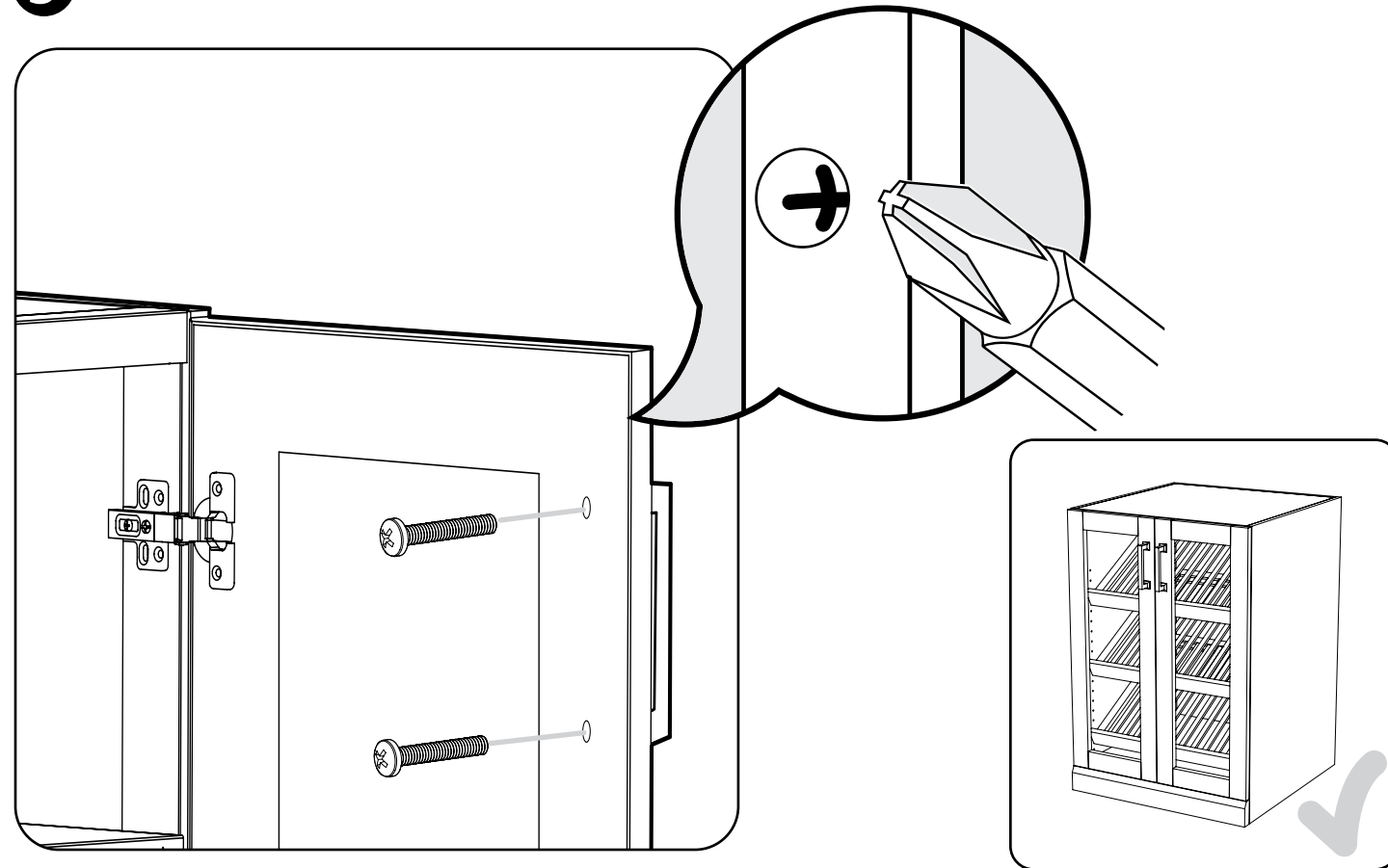

Fastening Cabinets

Note:
All shelves must be removed prior to fastening cabinets together.

4 Parts Needed.

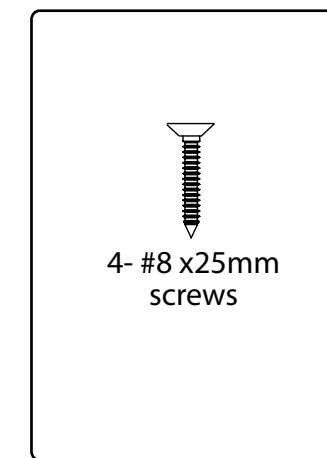

5 Drill 3/32" pilot holes on interior wall of cabinet being fastened.

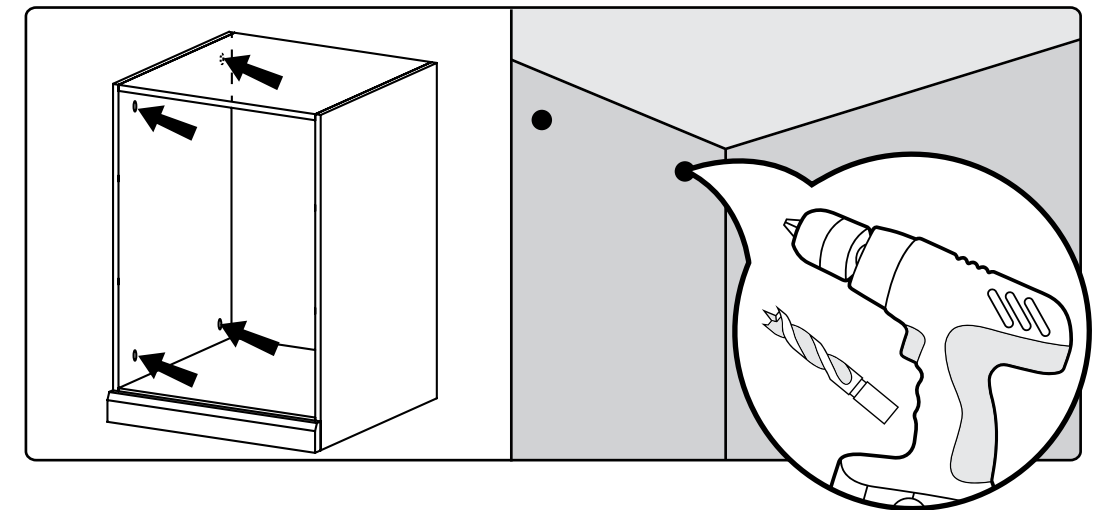

6 Using pilot hole as guides, screw into second cabinet. Do not over-tighten screws and punch through other side!

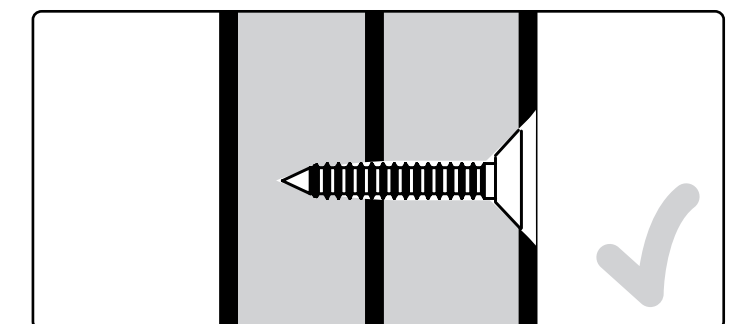
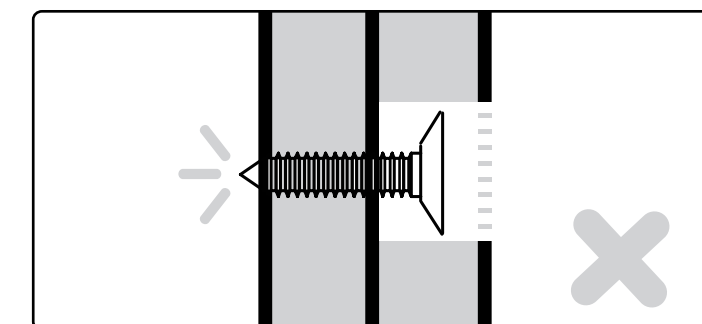
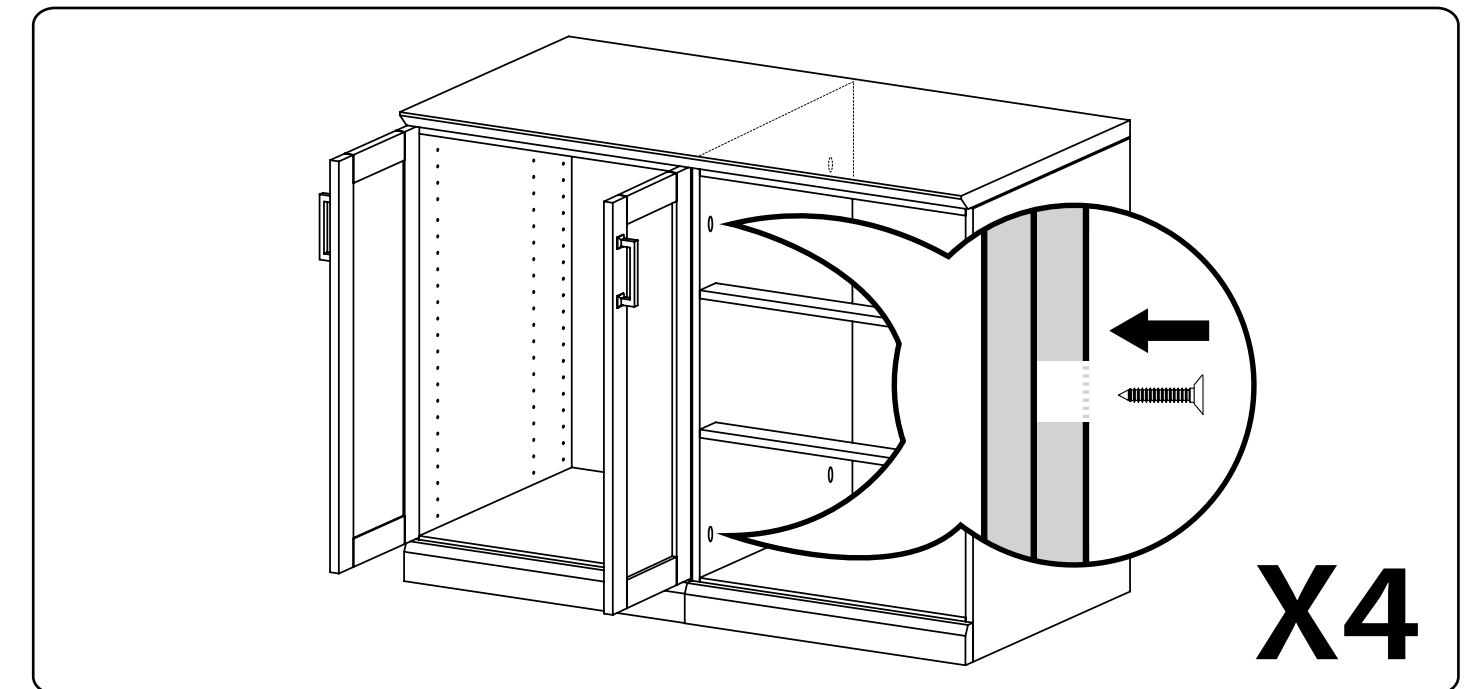

Mounting the Worktop

7 Parts Needed.

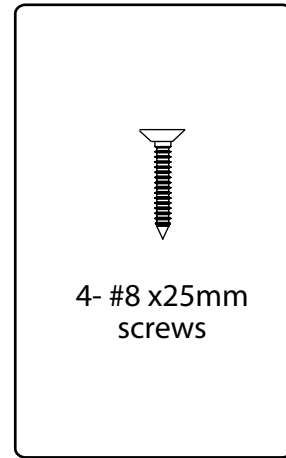

8 Place worktop over cabinets and lower onto cabinets.

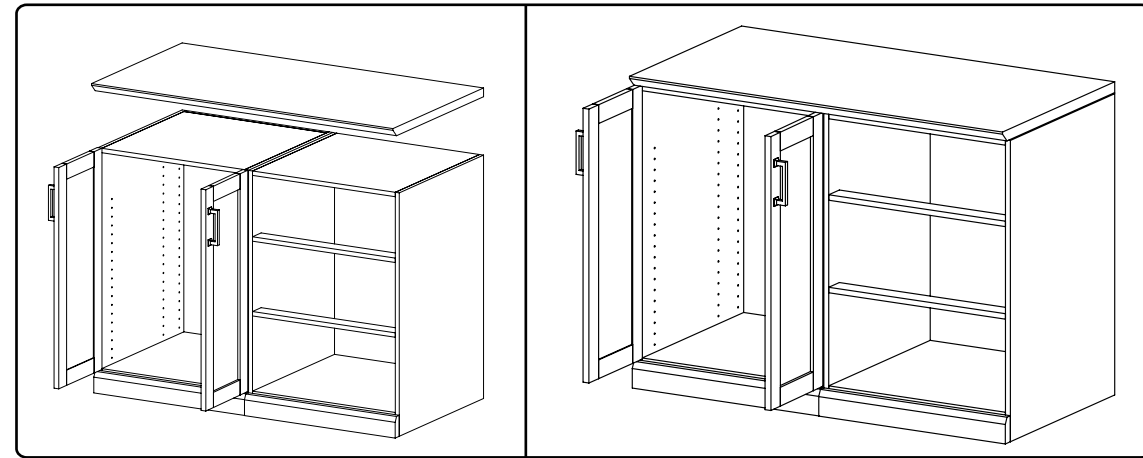

9 Drill 3/32" pilot holes on interior roof of cabinet.

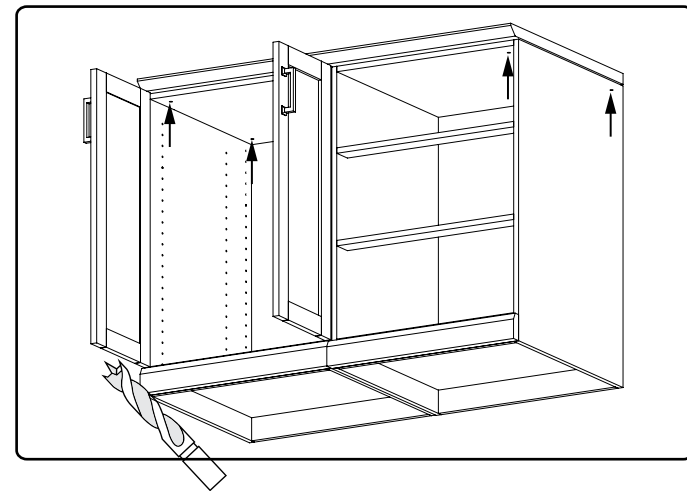

10 Tighten screws to secure cabinets.

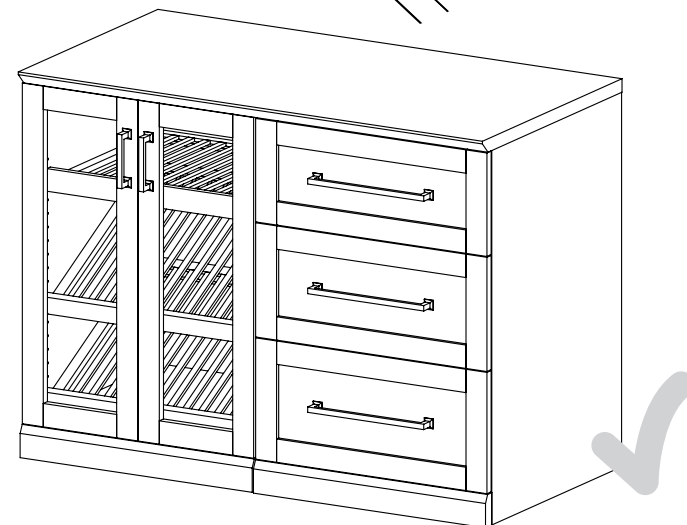
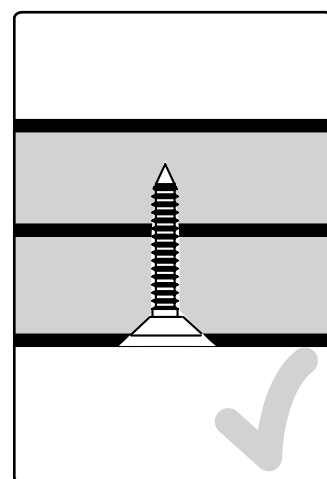
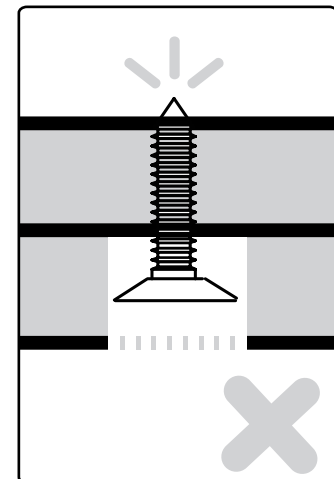
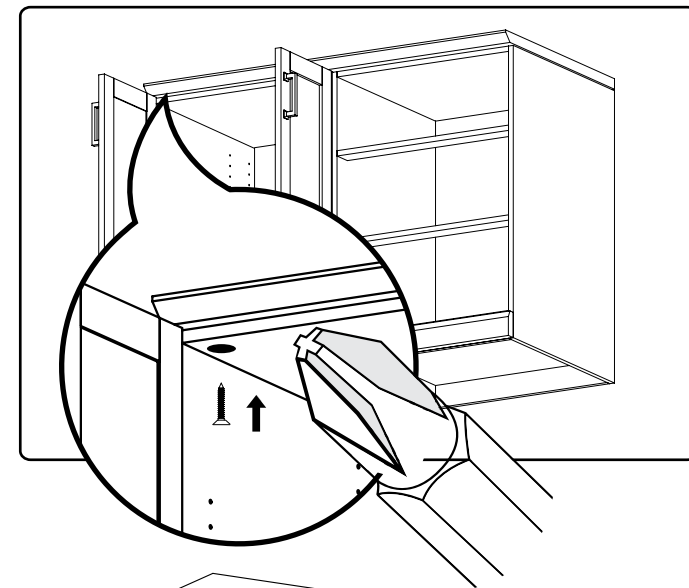

Inserting Cabinets Shelves on an angle

11 Open cabinet doors. Attach shelf clips to desired height.

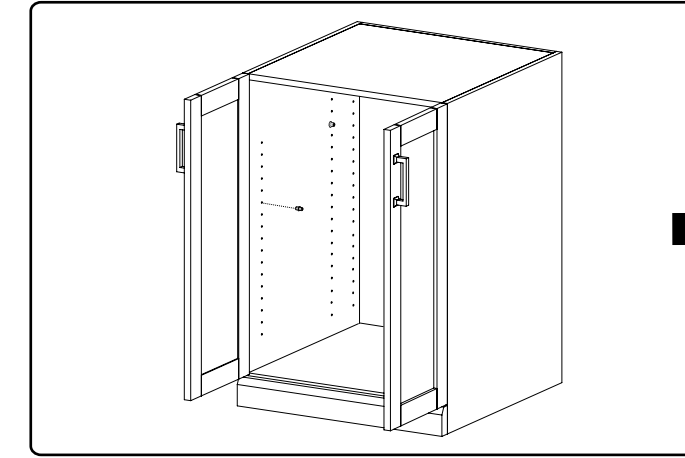

12 The shelf supports are inserted into front and middle hole positions.

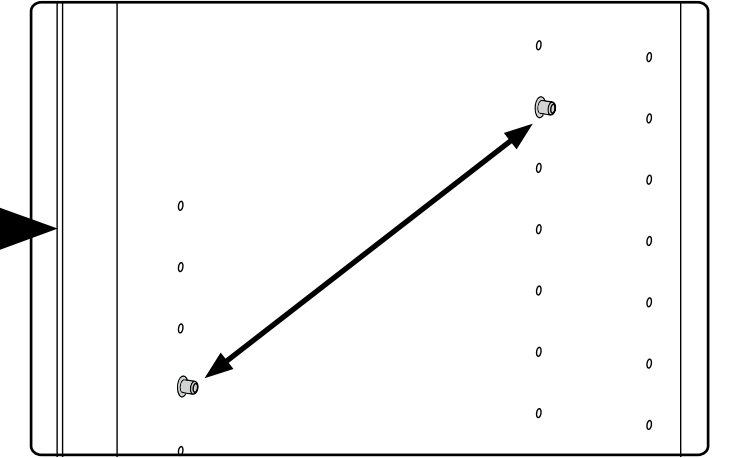

13 Insert rack at a slight angle and position over shelf supports.

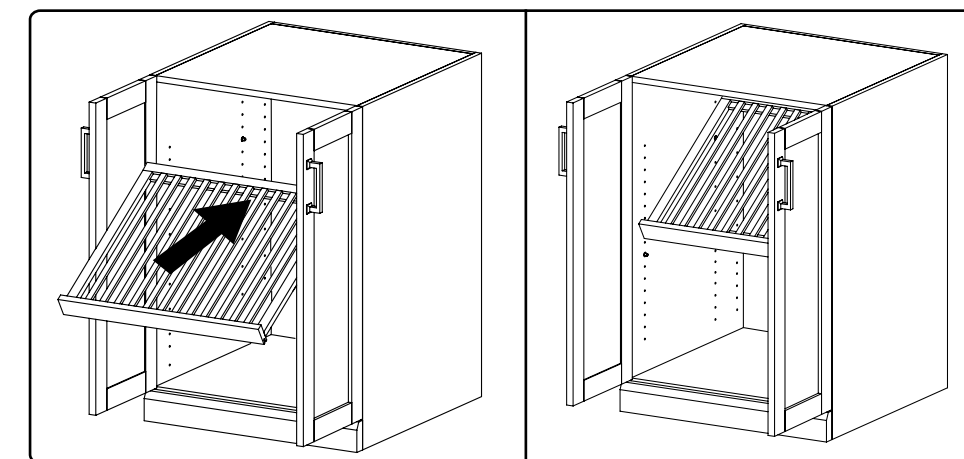

14 Lower shelf down onto shelf supports.

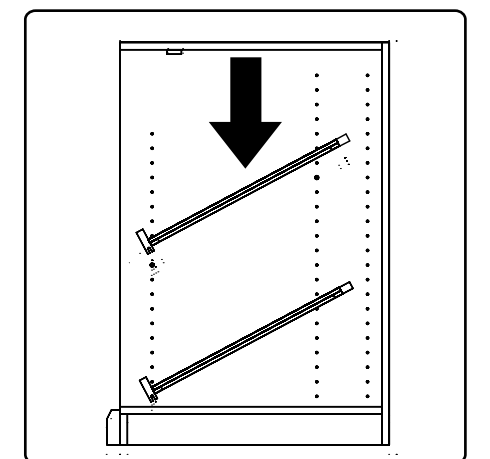

15 Ensure shelf supports sits in groove on lower edge of rack.

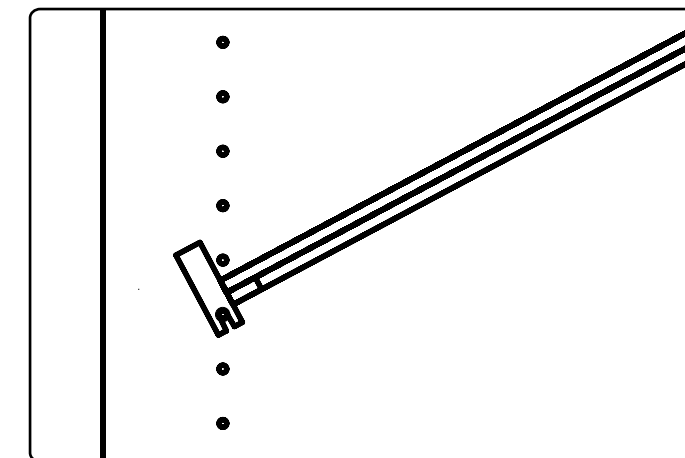

16 Insert remaining shelves.

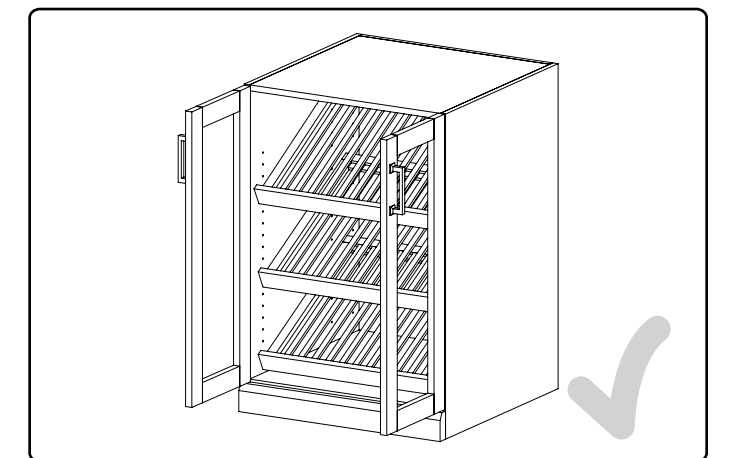

Inserting Cabinets Shelves Horizontal

17 Open cabinet doors. Attach shelf clips to desired height.

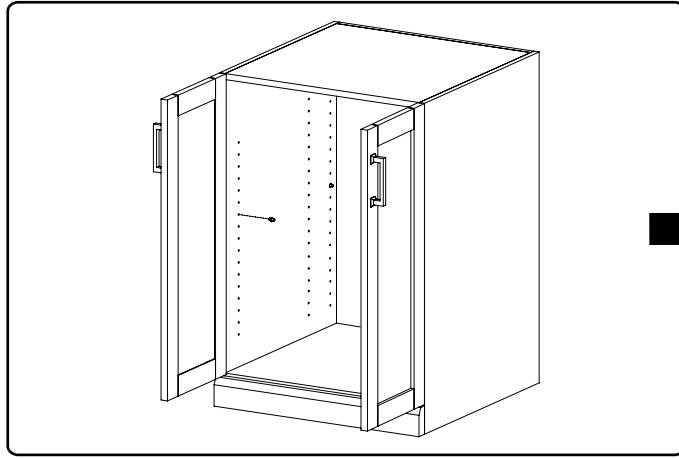

18 The shelf supports are inserted into front and back holes.

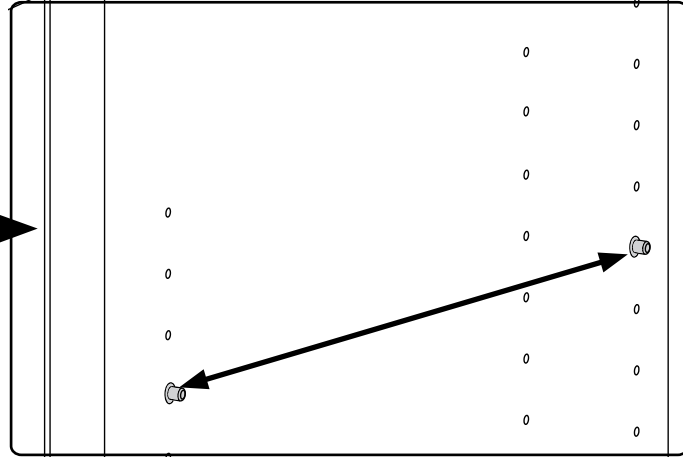

19 Insert rack at a slight angle and position over shelf supports.

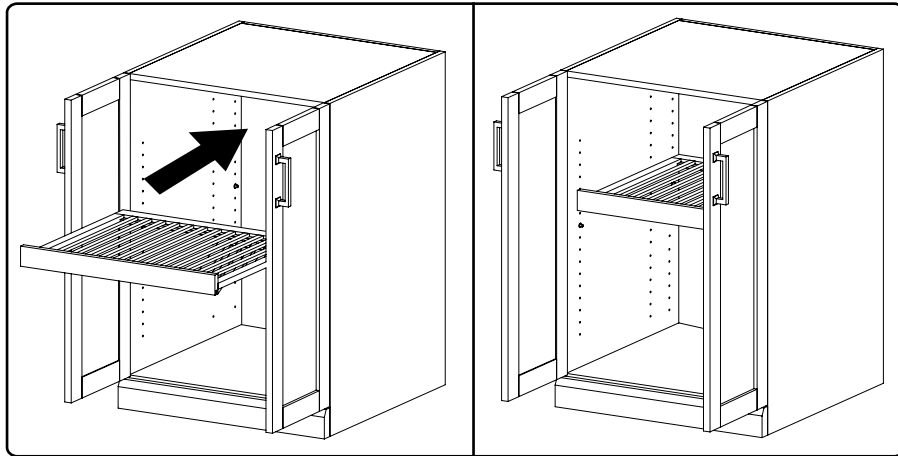

20 Lower shelf down onto shelf supports.

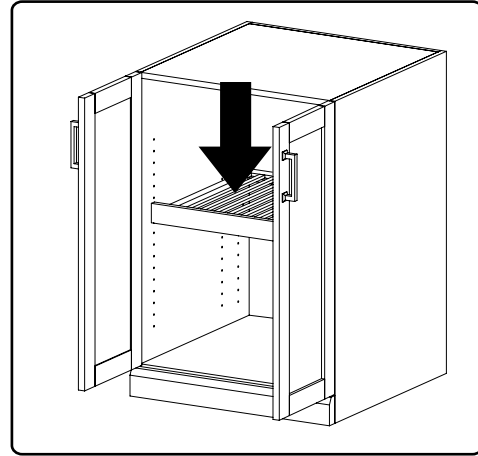

21 Lower shelf down onto shelf supports.

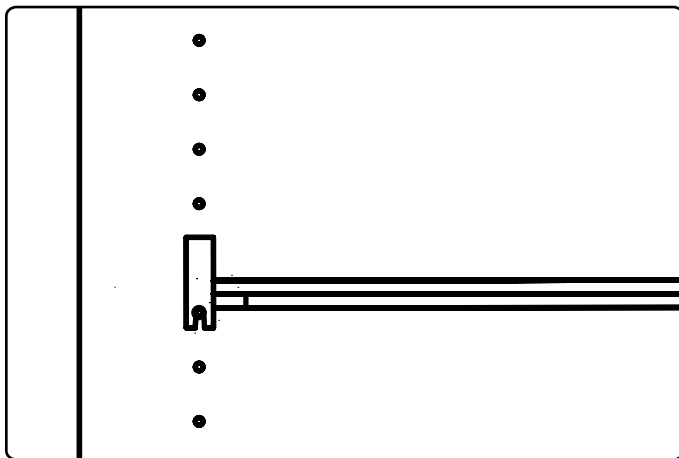

22 Insert remaining shelves.

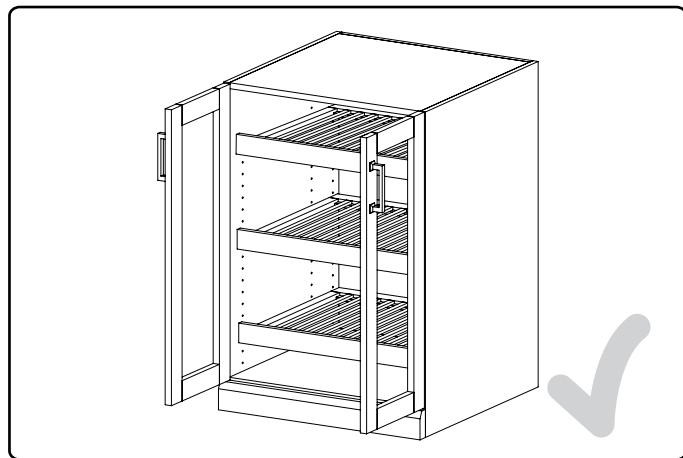

Adjusting The Door Hinges

Using a Philips screwdriver, the doors can be adjusted:
Left, right, forwards and backwards.

23 To adjust the doors left or right, turn the screw (A) clockwise or counterclockwise.

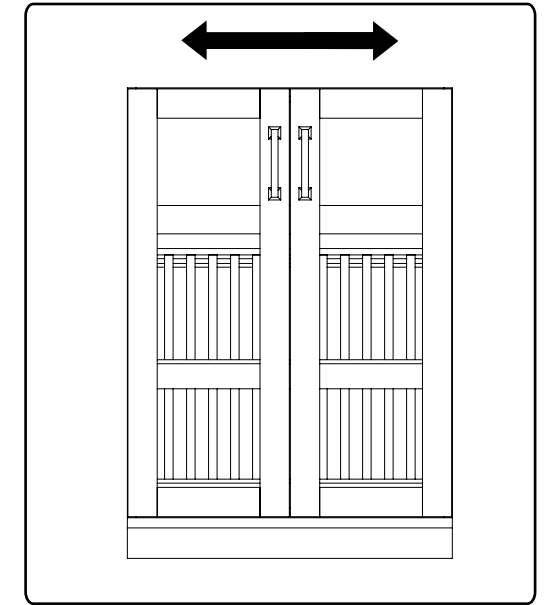
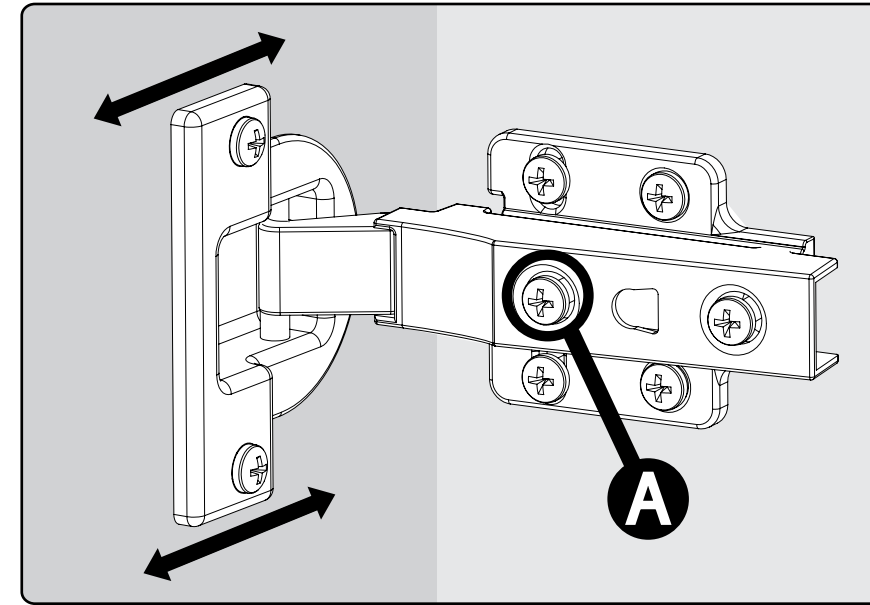

24 To adjust the gap between the doors and frame, turn the screw (B) clockwise or counterclockwise.

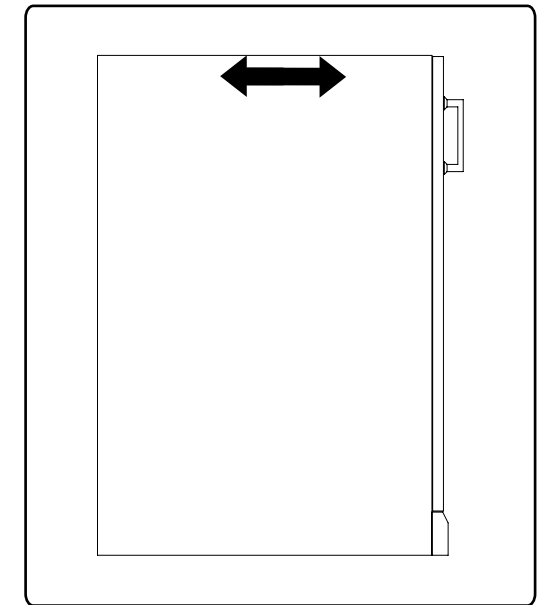
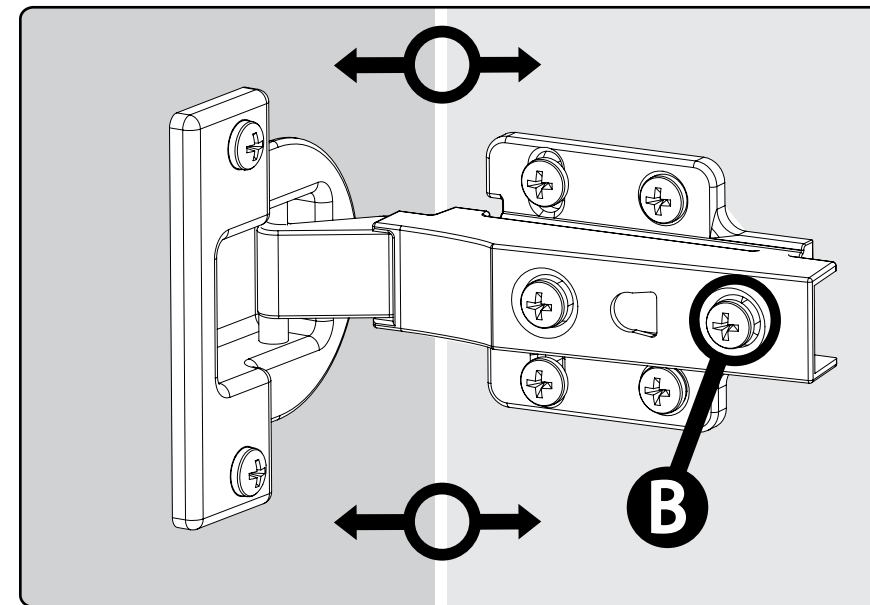

LED Light Guide

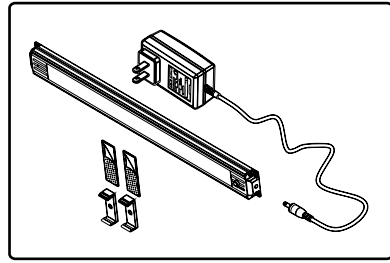

LED Light with power Adapter
SKU# 60836/60838

The adapter kit is used to connect to the electrical outlet, and contains the power on/off switch for the LED lights. It is used when one single light unit is needed or as the first light used when linking multiple light units together. It controls on/off power for all light units linked to it. Includes adapter, LED light, plastic clips, and double sided tape.

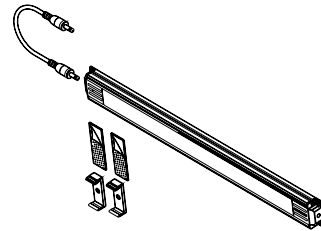

LED Light with Connector wire
SKU# 60837/60839

The connector kit is used when additional light units (up to 4) want to be linked together. It works in conjunction with and is controlled by the LED light with power adapter unit. Includes double sided tape and plastic clips.

How to connect the LED Lights

For LED Lights to work correctly, the adapter cable (A) must connect to end with on/off switch, for LED Light to be operational. Use connector cords (B) to connect additional lights. Up to 4 LED lights can be connected to one Power adapter cord (A).

NOTE: For Wall Switch Operation

If you are using a switch controlled power outlet to operate the LED Lights, the power adapter cord needs to plug into the end opposite the ON/OFF switch end.

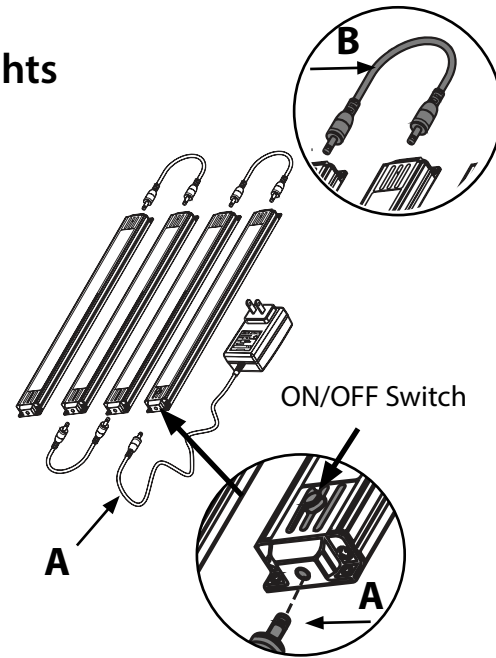

Installing LED Lights for Display Cabinets cont.

For bottom Display cabinet drill holes on back panel following Diagram 1. The hole can be placed on either side of cabinet at point A. or B., depending on outlet location. Using installation method from Steps 2 or 5 above center and install LED light 3 - 4 inches in from front.

