

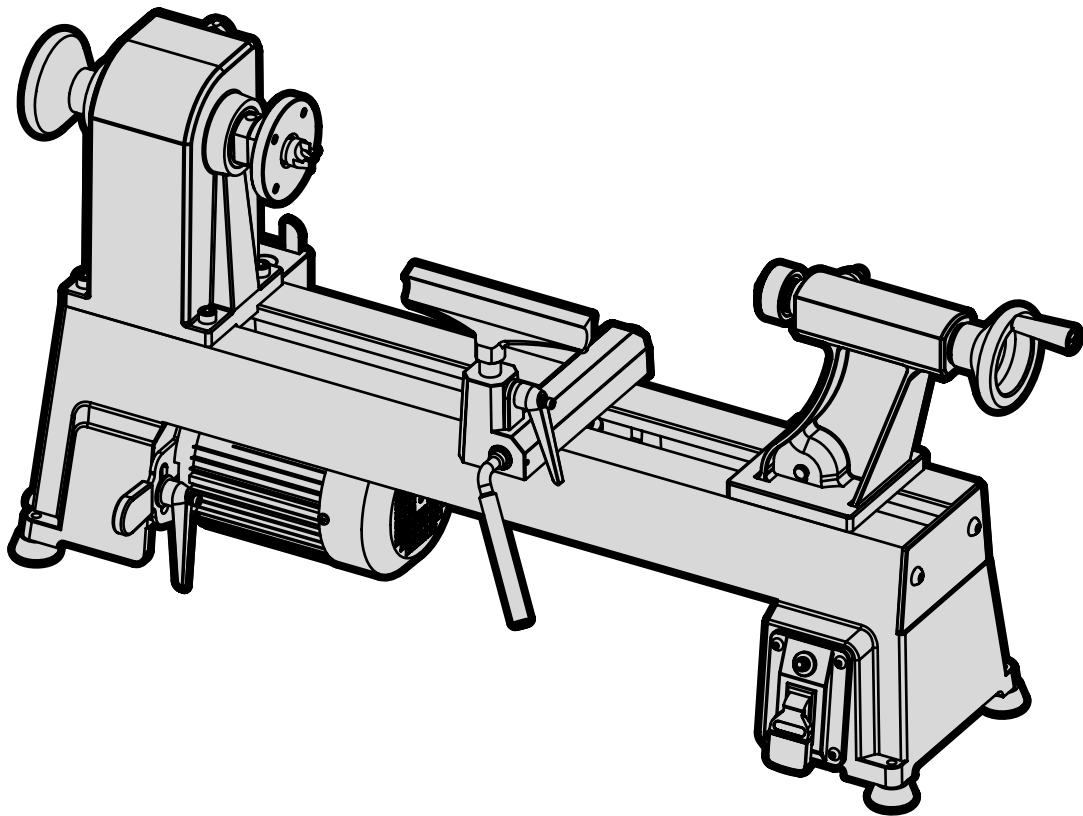

MODEL 3424, 3424T

12" x 18" 5-SPEED WOOD LATHE

Instruction Manual



NEED HELP? CONTACT US!

Have product questions? Need technical support? Please feel free to contact us:



1-800-232-1195 (M-F 8AM-5PM CST)



TECHSUPPORT@WENPRODUCTS.COM

IMPORTANT: Your new tool has been engineered and manufactured to WEN's highest standards for dependability, ease of operation, and operator safety. When properly cared for, this product will supply you years of rugged, trouble-free performance. Pay close attention to the rules for safe operation, warnings, and cautions. If you use your tool properly and for its intended purpose, you will enjoy years of safe, reliable service.

For replacement parts and the most up-to-date instruction manuals, visit ***WENPRODUCTS.COM***

CONTENTS

WELCOME	3
Introduction	3
Specifications.....	3
SAFETY	4
General Safety Rules	4
Wood Lathe Safety Warnings.....	6
Electrical Information.....	7
BEFORE OPERATING	8
Know Your Wood Lathe	8
Assembly	9
Adjustments.....	12
OPERATION & MAINTENANCE	14
Operation	14
Maintenance.....	19
Exploded View & Parts List.....	20
Troubleshooting Guide.....	23
Warranty Statement	24

To purchase chisels, lathe stands, live centers, and other accessories, visit **WENPRODUCTS.COM**

INTRODUCTION

Thanks for purchasing the WEN Wood Lathe. We know you are excited to put your tool to work, but first, please take a moment to read through the manual. Safe operation of this tool requires that you read and understand this operator's manual and all the labels affixed to the tool. This manual provides information regarding potential safety concerns, as well as helpful assembly and operating instructions for your tool.

⚠ SAFETY ALERT SYMBOL: Indicates danger, warning, or caution. The safety symbols and the explanations with them deserve your careful attention and understanding. Always follow the safety precautions to reduce the risk of fire, electric shock or personal injury. However, please note that these instructions and warnings are not substitutes for proper accident prevention measures.

NOTE: The following safety information is not meant to cover all possible conditions and situations that may occur. WEN reserves the right to change this product and specifications at any time without prior notice.

At WEN, we are continuously improving our products. If you find that your tool does not exactly match this manual, please visit wenproducts.com for the most up-to-date manual or contact our customer service at **1-800-232-1195**.

Keep this manual available to all users during the entire life of the tool and review it frequently to maximize safety for both yourself and others.

SPECIFICATIONS

Model Number	3424, 3424T
Motor	120V, 60 Hz, 4.5A
Swing Over Bed	12 Inches
Distance Between Centers	18 Inches
Single Speeds	520, 900, 1400, 2150, and 3400 RPM
Spindle Taper	MT2
Spindle Thread	1" - 8
Tailstock Taper	MT2
Quill Travel	2 Inches
Tool Rest Length	7-7/8 Inches
Face Plate Diameter	3-1/8 Inches
Product Dimensions	30-1/4 in. x 8-3/4 in. x 16-1/4 in.
Product Weight	70.3 lbs

GENERAL SAFETY RULES

 **WARNING!** Read all safety warnings and all instructions. Failure to follow the warnings and instructions may result in electric shock, fire and/or serious injury.

Safety is a combination of common sense, staying alert and knowing how your item works. The term “power tool” in the warnings refers to your mains-operated (corded) power tool or battery-operated (cordless) power tool.

SAVE THESE SAFETY INSTRUCTIONS.

WORK AREA SAFETY

- 1. Keep work area clean and well lit.** Cluttered or dark areas invite accidents.
- 2. Do not operate power tools in explosive atmospheres, such as in the presence of flammable liquids, gases or dust.** Power tools create sparks which may ignite the dust or fumes.
- 3. Keep children and bystanders away while operating a power tool.** Distractions can cause you to lose control.

ELECTRICAL SAFETY

- 1. Power tool plugs must match the outlet. Never modify the plug in any way. Do not use any adapter plugs with earthed (grounded) power tools.** Unmodified plugs and matching outlets will reduce risk of electric shock.
- 2. Avoid body contact with earthed or grounded surfaces such as pipes, radiators, ranges and refrigerators.** There is an increased risk of electric shock if your body is earthed or grounded.
- 3. Do not expose power tools to rain or wet conditions.** Water entering a power tool will increase the risk of electric shock.
- 4. Do not abuse the cord. Never use the cord for carrying, pulling or unplugging the power tool. Keep cord away from heat, oil, sharp edges or moving parts.** Damaged or entangled cords increase the risk of electric shock.
- 5. When operating a power tool outdoors, use an extension cord suitable for outdoor use.** Use of a cord suitable for outdoor use reduces the risk of electric shock.

6. If operating a power tool in a damp location is unavoidable, use a ground fault circuit interrupter (GFCI) protected supply. Use of a GFCI reduces the risk of electric shock.

PERSONAL SAFETY

- 1. Stay alert, watch what you are doing and use common sense when operating a power tool. Do not use a power tool while you are tired or under the influence of drugs, alcohol or medication.** A moment of inattention while operating power tools may result in serious personal injury.
- 2. Use personal protective equipment. Always wear eye protection.** Protective equipment such as a respiratory mask, non-skid safety shoes and hearing protection used for appropriate conditions will reduce the risk of personal injury.
- 3. Prevent unintentional starting. Ensure the switch is in the off-position before connecting to power source and/or battery pack, picking up or carrying the tool.** Carrying power tools with your finger on the switch or energizing power tools that have the switch on invites accidents.
- 4. Remove any adjusting key or wrench before turning the power tool on.** A wrench or a key left attached to a rotating part of the power tool may result in personal injury.
- 5. Do not overreach. Keep proper footing and balance at all times.** This enables better control of the power tool in unexpected situations.
- 6. Dress properly. Do not wear loose clothing or jewelry. Keep your hair and clothing away from moving parts.** Loose clothes, jewelry or long hair can be caught in moving parts.

GENERAL SAFETY RULES

⚠ WARNING! Read all safety warnings and all instructions. Failure to follow the warnings and instructions may result in electric shock, fire and/or serious injury.

Safety is a combination of common sense, staying alert and knowing how your item works. The term “power tool” in the warnings refers to your mains-operated (corded) power tool or battery-operated (cordless) power tool.

SAVE THESE SAFETY INSTRUCTIONS.

7. If devices are provided for the connection of dust extraction and collection facilities, ensure these are connected and properly used. Use of dust collection can reduce dust-related hazards.

POWER TOOL USE AND CARE

1. Do not force the power tool. Use the correct power tool for your application. The correct power tool will do the job better and safer at the rate for which it was designed.

2. Do not use the power tool if the switch does not turn it on and off. Any power tool that cannot be controlled with the switch is dangerous and must be repaired.

3. Disconnect the plug from the power source and/or the battery pack from the power tool before making any adjustments, changing accessories, or storing power tools. Such preventive safety measures reduce the risk of starting the power tool accidentally.

4. Store idle power tools out of the reach of children and do not allow persons unfamiliar with the power tool or these instructions to operate the power tool. Power tools are dangerous in the hands of untrained users.

5. Maintain power tools. Check for misalignment or binding of moving parts, breakage of parts and any other condition that may affect the power tool's operation. If damaged, have the power tool repaired before use. Many accidents are caused by poorly maintained power tools.

6. Keep cutting tools sharp and clean. Properly maintained cutting tools with sharp cutting edges are less likely to bind and are easier to control.

7. Use the power tool, accessories and tool bits, etc. in accordance with these instructions, taking into account the working conditions and the work to be performed. Use of the power tool for operations different from those intended could result in a hazardous situation.

8. Use clamps to secure your workpiece to a stable surface. Holding a workpiece by hand or using your body to support it may lead to loss of control.

9. KEEP GUARDS IN PLACE and in working order.

SERVICE

1. Have your power tool serviced by a qualified repair person using only identical replacement parts. This will ensure that the safety of the power tool is maintained.

CALIFORNIA PROPOSITION 65 WARNING

Some dust created by power sanding, sawing, grinding, drilling, and other construction activities may contain chemicals, including lead, known to the State of California to cause cancer, birth defects, or other reproductive harm. Wash hands after handling. Some examples of these chemicals are:

- Lead from lead-based paints.
- Crystalline silica from bricks, cement, and other masonry products.
- Arsenic and chromium from chemically treated lumber.

Your risk from these exposures varies depending on how often you do this type of work. To reduce your exposure to these chemicals, work in a well-ventilated area with approved safety equipment such as dust masks specially designed to filter out microscopic particles.

WOOD LATHE SAFETY WARNINGS

 **WARNING!** Do not operate the power tool until you have read and understood the following instructions and the warning labels.

WOOD LATHE SAFETY

1. This lathe is designed and intended for use by properly trained and experienced personnel only. If you are not familiar with the proper and safe operation of a lathe, do not use it until proper training and knowledge have been acquired.
2. Always wear eye protection and a face shield/dust mask when using the lathe.
3. Do not wear loose clothing or jewelry when using the lathe. Keep your hair, clothing and gloves away from moving parts. Loose clothes, jewelry or long hair can be caught in the spinning tool.
4. Select the right tool for your task at hand. Make sure all tools, chisels and accessories are sharp before using them. Do not use dull or damaged tools.
5. Select the appropriate speed for the task. Use slower speeds when starting on a workpiece. Allow the lathe to ramp up to the operating speed before engaging any chisels, tools or other carving accessories.
6. Check the workpiece carefully for splits, knots, nails, or other obstructions. These types of blemishes may cause a safety hazards during turning.
7. If gluing up a workpiece for turning, always use a high quality glue that meets the needs of the particular workpiece to prevent the workpiece from falling off during operation.
8. Cut the workpiece to a rough outline of the finished shape before mounting it on the lathe.
9. Rotate the workpiece by hand to check clearance with the tool rest before turning the machine on.
10. When turning between centers, make sure the headstock and tailstock are tight and snug against the workpiece.
11. Never apply coolants or water to a spinning workpiece.
12. Never stop a rotating workpiece with your hand.
13. Do not change speeds until the machine comes to a complete stop.
14. Turn off and unplug the machine before doing any cleaning or maintenance. Use a brush or compressed air to remove chips or debris. Never use your hands to remove excess material and debris.

These safety instructions can't possibly warn of every scenario that may arise with this tool, so always make sure to stay alert and use common sense during operation.

ELECTRICAL INFORMATION

GROUNDING INSTRUCTIONS

In the event of a malfunction or breakdown, grounding provides the path of least resistance for an electric current and reduces the risk of electric shock. This tool is equipped with an electric cord that has an equipment grounding conductor and a grounding plug. The plug **MUST** be plugged into a matching outlet that is properly installed and grounded in accordance with ALL local codes and ordinances.

1. Do not modify the plug provided. If it will not fit the outlet, have the proper outlet installed by a licensed electrician.

2. Improper connection of the equipment grounding conductor can result in electric shock. The conductor with the green insulation (with or without yellow stripes) is the equipment grounding conductor. If repair or replacement of the electric cord or plug is necessary, **DO NOT** connect the equipment grounding conductor to a live terminal.

3. Check with a licensed electrician or service personnel if you do not completely understand the grounding instructions or whether the tool is properly grounded.

4. Use only three-wire extension cords that have three-pronged plugs and outlets that accept the tool's plug. Repair or replace a damaged or worn cord immediately.

CAUTION! In all cases, make certain the outlet in question is properly grounded. If you are not sure, have a licensed electrician check the outlet.

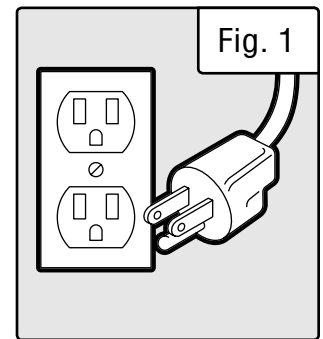

GUIDELINES AND RECOMMENDATIONS FOR EXTENSION CORDS

When using an extension cord, be sure to use one heavy enough to carry the current your product will draw. An undersized cord will cause a drop in line voltage resulting in loss of power and overheating. The table below shows the correct size to be used according to cord length and ampere rating. When in doubt, use a heavier cord. The smaller the gauge number, the heavier the cord.

AMPERAGE	REQUIRED GAUGE FOR EXTENSION CORDS			
	25 ft.	50 ft.	100 ft.	150 ft.
4.5A	18 gauge	16 gauge	16 gauge	14 gauge

1. Examine extension cord before use. Make sure your extension cord is properly wired and in good condition. Always replace a damaged extension cord or have it repaired by a qualified person before using it.

2. Do not abuse extension cord. Do not pull on cord to disconnect from receptacle; always disconnect by pulling on plug. Disconnect the extension cord from the receptacle before disconnecting the product from the extension cord. Protect your extension cords from sharp objects, excessive heat and damp/wet areas.

3. Use a separate electrical circuit for your tool. This circuit must not be less than a 12-gauge wire and should be protected with a 15A time-delayed fuse. Before connecting the motor to the power line, make sure the switch is in the OFF position and the electric current is rated the same as the current stamped on the motor nameplate. Running at a lower voltage will damage the motor.

KNOW YOUR WOOD LATHE

UNPACKING

With the help of a friend or trustworthy foe, carefully remove the wood lathe from the packaging. Do not discard the packaging until all of the parts below are accounted for. If any part is damaged or missing, please contact our customer service at **1-(800) 232-1195, M-F 8-5 CST** or email us at **techsupport@wenproducts.com**.

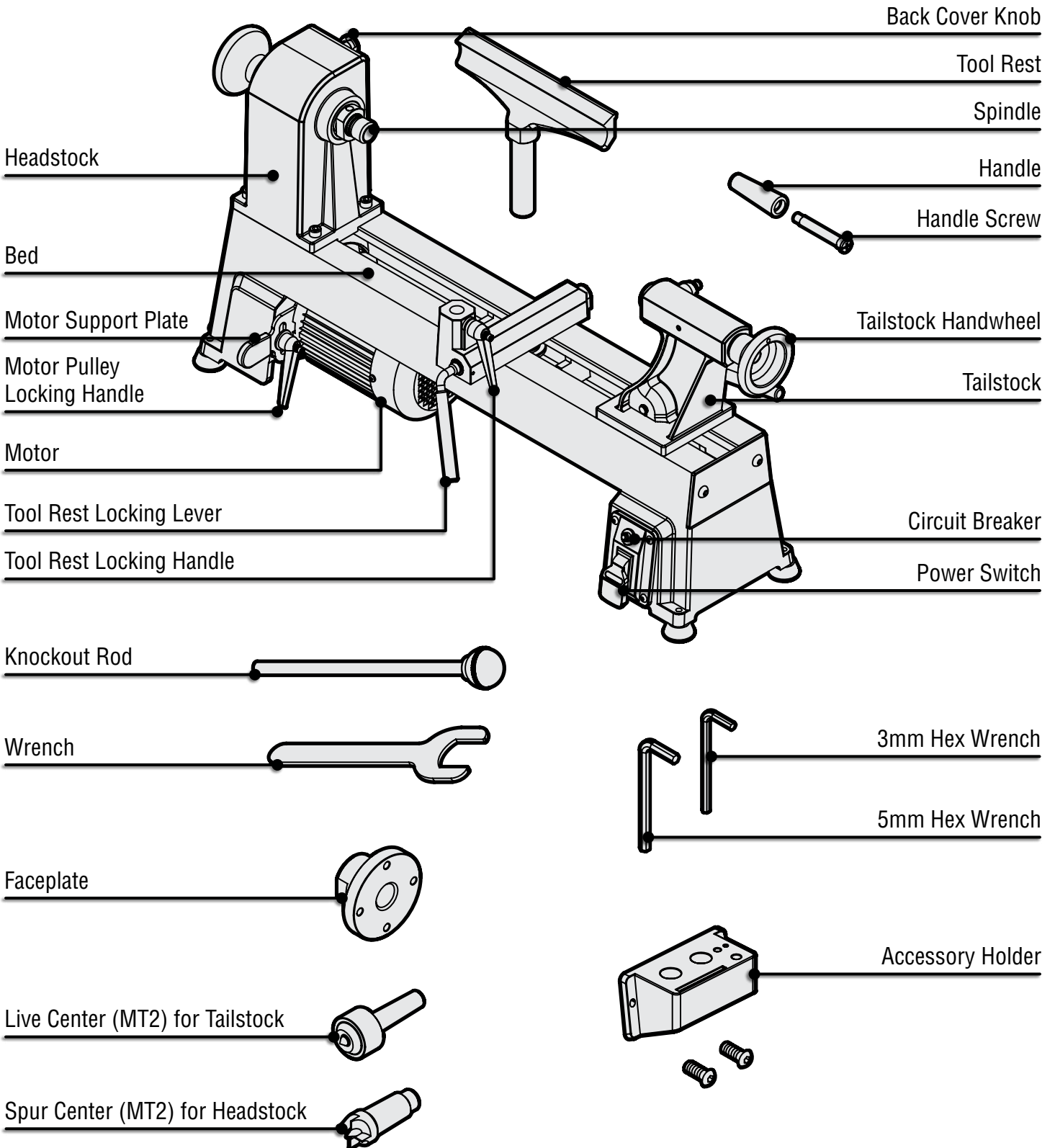

ASSEMBLY

⚠ WARNING: To prevent injury from accidental operation, make sure the tool is switched OFF and unplugged from the power source before assembling or making any adjustments.

REMOVING THE ANTI-RUST GREASE

The lathe bed and centers have been coated with grease to prevent them from rusting.

1. Remove the excess oil and grease by wiping it off with a clean cloth.
2. Remove any residue with a rag moistened with acetone, kerosene, or other removal agent. Wear gloves to protect your skin. Do not use gasoline, or cellulose-based solvents such as paint thinner or lacquer thinner, as these will damage the painted surfaces.
3. Apply a light coat of good-quality paste wax to the surfaces to guard against rust and corrosion.

INSTALLING THE HANDLE (FIG. A)

1. Insert the handle screw (Fig. A - 1) through the handle (Fig. A - 2) and into the hole of the handwheel (Fig. A - 3).
2. Tighten the handle screw using a flathead screwdriver (not included).

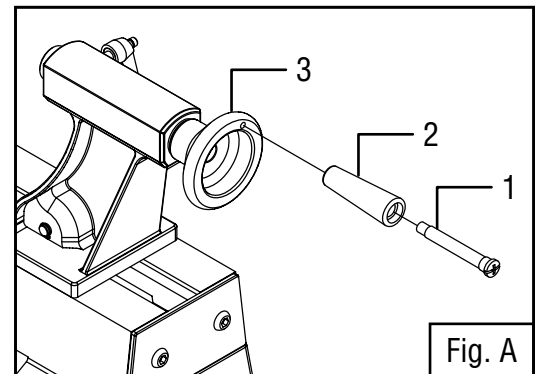

INSTALLING THE TOOL REST (FIG. B)

1. Loosen the locking handle (Fig. B - 1) and insert the tool rest (Fig. B - 2) into the tool rest base.
2. Adjust the tool rest height up or down to the desired position and then tighten the locking handle (Fig. B - 1).

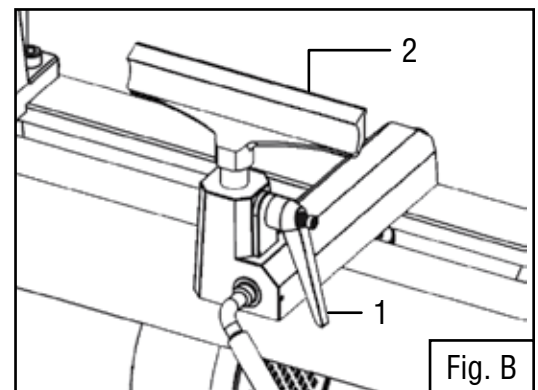

INSTALLING/REMOVING THE FACE PLATE (FIG. C)

1. Mount the face plate (Fig. C - 1) onto the spindle by screwing it clockwise as far as it will go onto the spindle threads.
2. Then insert the knockout rod (Fig. C - 2) into the hole to lock the spindle and use the wrench (Fig. C - 3) to fully tighten the face plate.

To remove the face plate, insert the knockout rod into the hole and use the wrench to loosen the face plate.

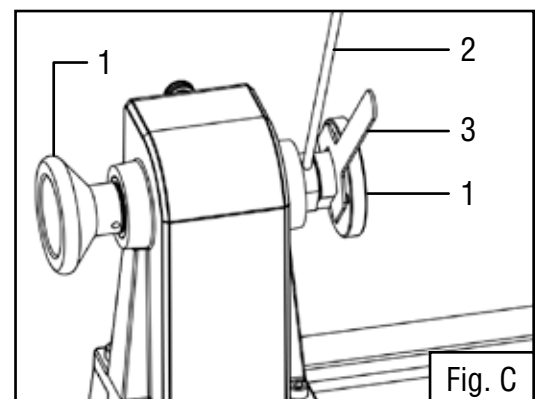

ASSEMBLY

INSTALLING THE SPUR CENTER (FIG. D)

1. Make sure the mating surfaces of both the spur center and the headstock spindle are clean.
2. Drive the spur center (Fig. D - 1) into the workpiece (Fig. D - 2) using a rubber mallet or a piece of scrap wood.
3. Push the spur center through the face plate into the spindle on the headstock.

NOTE: It is not necessary to remove the face plate to install the spur center.

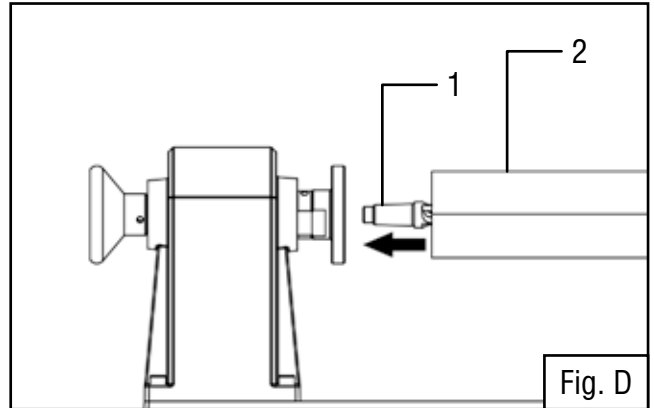

Fig. D

REMOVING THE SPUR CENTER (FIG. E)

The workpiece can be mounted between the spur center and live center, or it can be mounted onto the face plate. Remove the spur center before mounting workpiece onto the face plate.

1. Hold the spur center (Fig. E - 1) to prevent it from falling. Use a rag to protect your hand from the sharp edges.
2. Insert the knockout rod (Fig. E - 2) through the spindle hole to tap out the spur center.

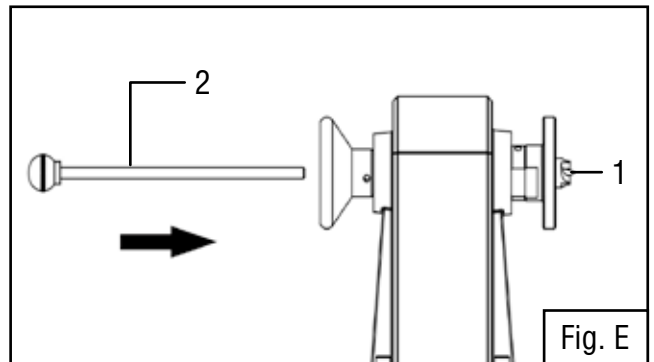

Fig. E

INSTALLING THE LIVE CENTER (FIG. F)

1. Rotate the tailstock handwheel (Fig. F - 1) clockwise a few times to advance the quill (Fig. F - 2) forward.
2. Push the live center (Fig. F - 3) into the quill.

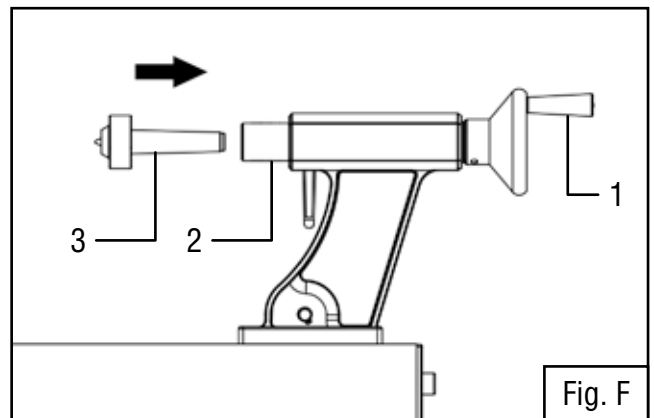

Fig. F

REMOVING THE LIVE CENTER (FIG. G)

1. Hold the live center (Fig. G - 1) to prevent it from falling. Use a rag to protect your hand from the sharp edges.
2. Rotate the handwheel (Fig. G - 2) counterclockwise to retract the quill until the live center is released from the quill.

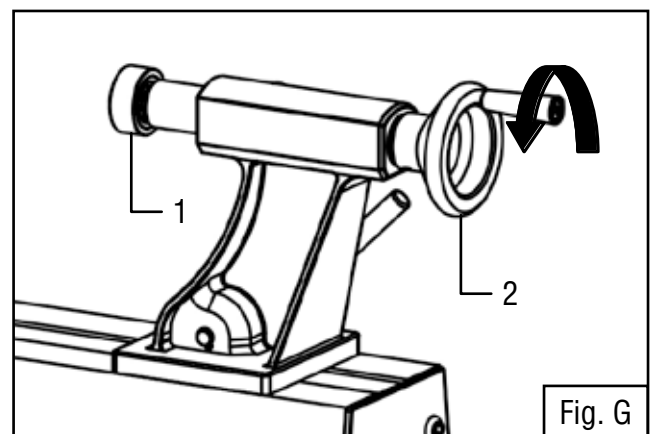

Fig. G

ASSEMBLY

INSTALLING THE ACCESSORY HOLDER (FIG. H & I)

1. Position the accessory holder (Fig. H - 1) below the headstock on the back of the base. Align the holes and secure the accessory holder using two M5×12 pan head screws (Fig. H - 2). Tighten the screws using the 3mm hex wrench.

You can organize your wrench, hex wrenches, knockout rod, live center and spur center into the accessory holder as shown in Fig. I.

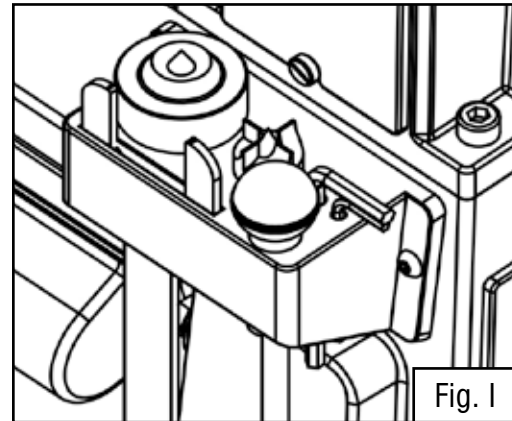
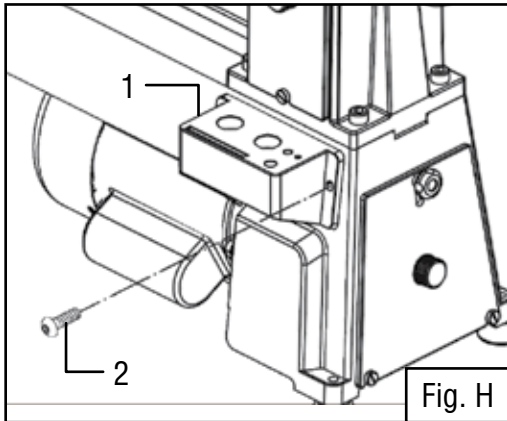

MOUNTING THE LATHE TO A BENCHTOP (FIG. J)

For effective and safe operation, the lathe must be mounted to a bench table. Place the machine on a stable, flat work surface. Make sure there is sufficient open space around the machine for operation and adjustments. Route the power cord so that it will not make contact with the lathe's moving parts.

Refer to the graph below (Fig. J) for your lathe's base dimensions. Mount the machine's base to the benchtop with rubber feet in between to help dampen the vibration. Threaded holes on the lathe's base are M8-1.25. Mounting hardware is not included.

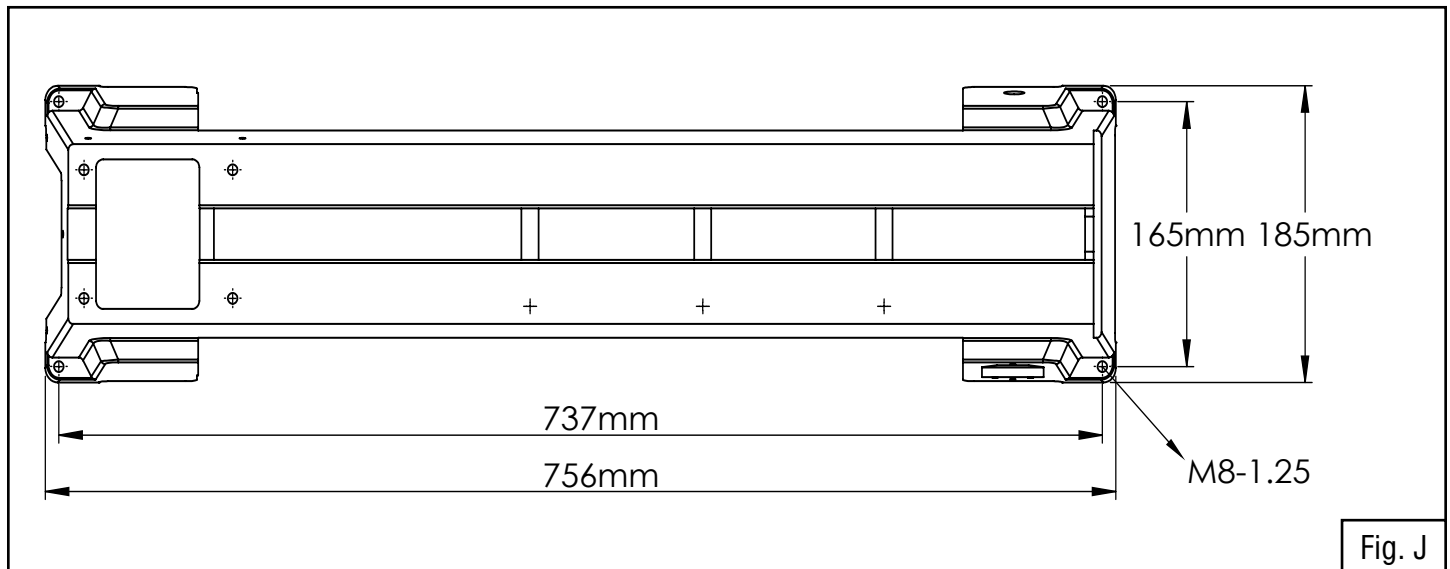

ADJUSTMENTS

TOOL REST ADJUSTMENTS (FIG. K)

You can adjust the height, position and angle of the tool rest assembly (Fig. K - 1) to suit your task at hand. To adjust the tool rest:

1. Loosen the small locking handle (Fig. K - 2) to raise and lower the tool rest or to adjust its angle. Tighten the handle to secure the tool rest.
2. Loosen the locking lever (Fig. K - 3) on the tool rest base to slide the base back and forth or to adjust its angle. Tighten the locking lever firmly before operating the lathe.

NOTE: Adjust the height of the tool rest just below the center of the workpiece, so that the tool will cut at the center of the workpiece.

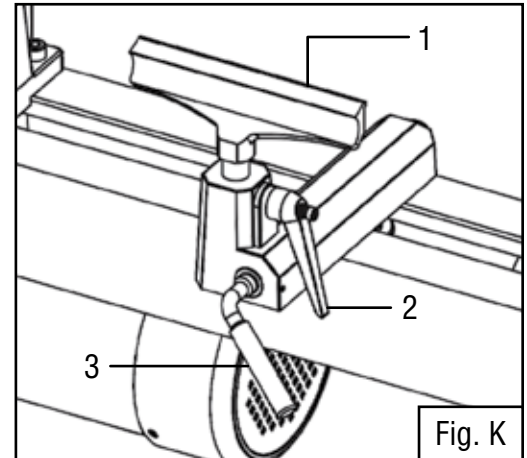

TAILSTOCK ADJUSTMENTS (FIG. L)

1. Loosen the tailstock locking lever (Fig. L - 1) and slide the tailstock into the desired position. Retighten the locking lever.

2. Loosen the quill locking handle (Fig. L - 2) to unlock the tailstock quill. Use the handwheel (Fig. L - 3) to advance and retract the quill. Retighten the quill locking handle.

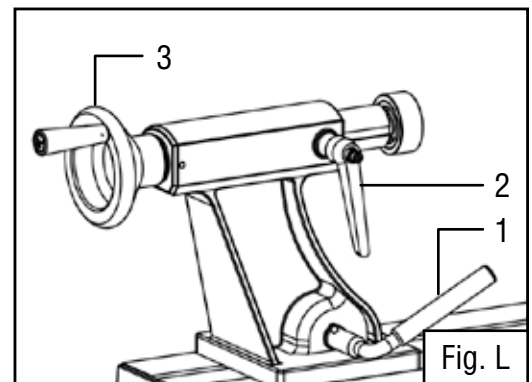

ADJUSTMENTS

SPEED ADJUSTMENTS (FIG. M TO P)

This lathe has five speeds (520, 900, 1400, 2150 and 3400 RPM) as shown on the speed label (Fig. M). To change the speed:

1. Loosen the back cover knob (Fig. N - 1), then pull up and open the back cover (Fig. N - 2) to access the spindle pulley.
2. Loosen the side cover knob (Fig. O - 1), pull up and open the side cover (Fig. O - 2) to access the motor pulley.
3. Release the motor pulley locking handle (Fig. P - 1) and pull up on the motor plate flange (Fig. P - 2) to loosen the tension on the drive belt. Place the drive belt between the spindle pulley and motor pulley as shown in Fig. M to achieve the desired speed setting.

NOTE: Always start at slower speeds for rough cuts and when working on larger workpieces. Use faster speeds for more refined cuts and detailed work.

4. Re-tension the belt tension and lock the handle. Replace the back cover and side cover.

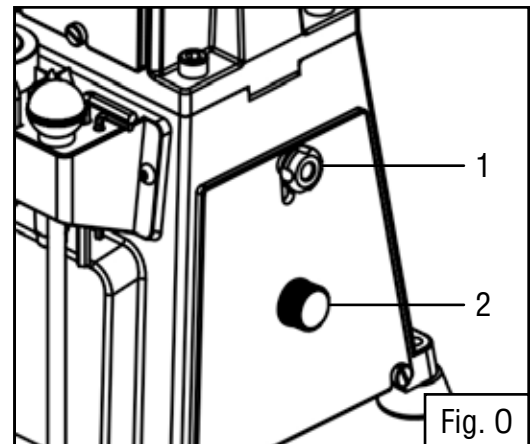
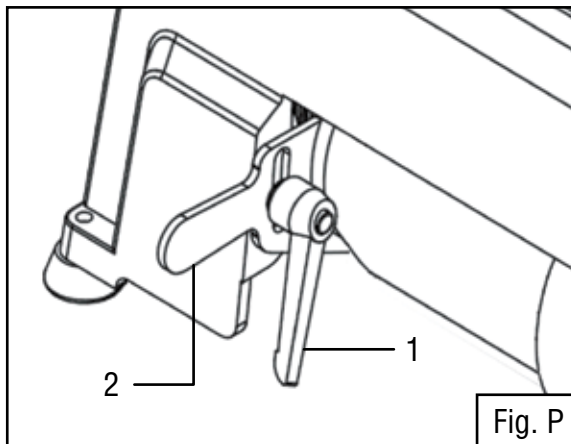
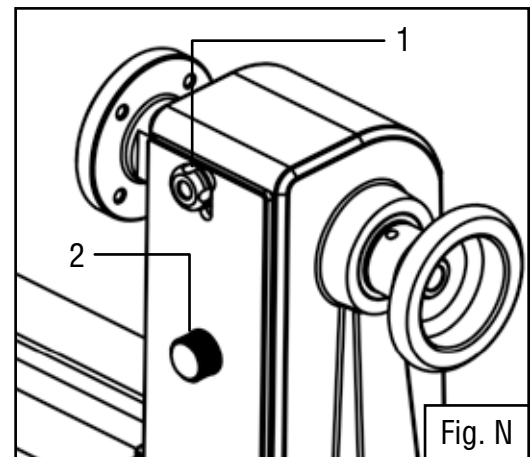
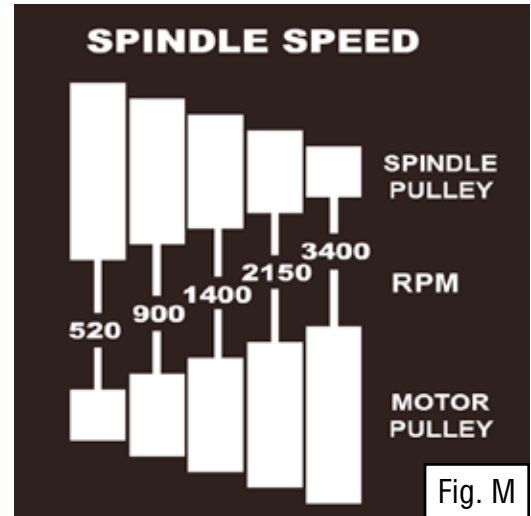

OPERATION

TURNING TOOLS

If possible, select only quality high-speed steel turning tools. High-speed steel tools hold an edge and last longer than ordinary carbon steel. As one becomes proficient in turning, a variety of specialty tools for specific applications can be acquired. The following tools provide the basics for most wood-turning projects. Sharp tools must be used; do not use dull or damaged tools.

1. Large roughing gouge - use this tool to shape square or out-of-round spindle-turning stock into a cylinder. This can also be used for creating shallow coves.

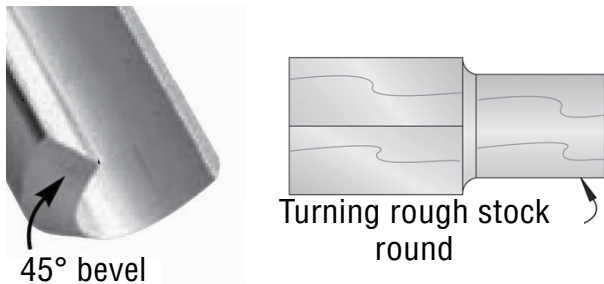

2. Skew chisel - the skew evens out high and low spots to shape the cylinders. Vary angle at which the tip meets the workpiece to change the aggressiveness of the cut. This can also be used for cutting beads and V-grooves.

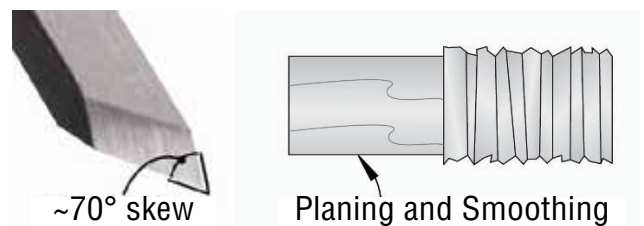

3. Spindle gouge - the spindle gouge cuts coves, beads and free-form contours. It can also be used for producing shallow hollows on faceplate turnings.

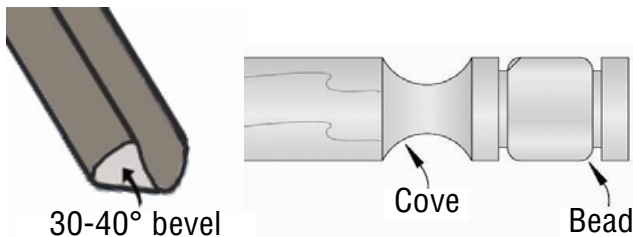

4. Parting tool - use the parting tool to form grooves and tenons and to remove stock. It can also be used for rolling small beads.

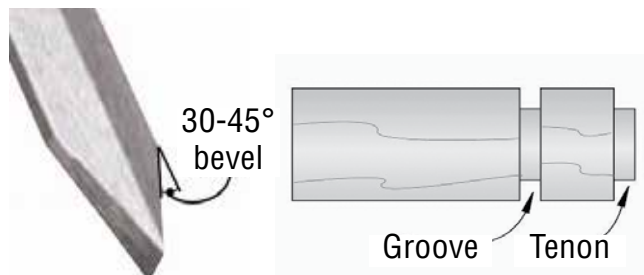

5. Bowl gouge - the bowl gouge cuts external and internal profiles on faceplate-mounted stock, such as bowls and platters. It can also be used for creating ultra smooth cuts on bowls and spindles by using it as a shearing scraper.

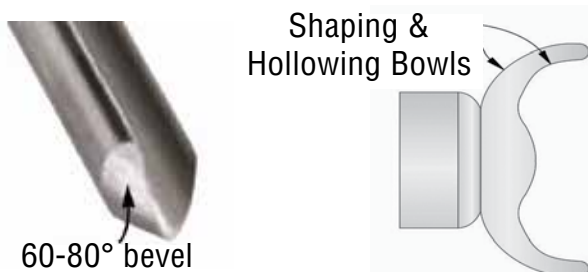

6. Round nose scraper - use this scraper for non-aggressive shaping of spindles and bowls and to smooth out surfaces without removing too much stock.

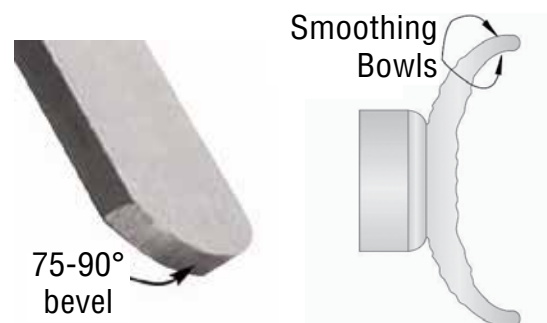

OPERATION

⚠ WARNING: To prevent serious injury, make sure all the warnings and instructions have been read and understood before operating this tool.

MOUNTING THE WORKPIECE BETWEEN SPINDLES (FIG. Q & R)

Spindle turning takes place between the centers of the lathe. It requires a spur center in the headstock and a live center in the tailstock. Stock for spindles should be straight grained and free of cracks, knots, nails and other defects. A cup center rather than a cone center in the tailstock will often reduce the risk of splitting the stock.

1. With a combination square, locate and mark the center on each end of the workpiece. Accuracy is not critical on full rounds but is extremely important on stock where square sections are to remain. Put a dimple in the stock with an awl or nail (or use a spring-loaded automatic center punch).

NOTE: Extremely hard woods may require kerfs cut into the ends of the stock using a band saw, so the wood will accept the spur center and the live center.

2. Drive the spur center about .1 inches (3 mm) into the workpiece (Fig. Q). Use a wood mallet or dead blow hammer. Be careful that you do not split the workpiece. Never use a steel face hammer and never drive the workpiece onto the spur center while it is mounted on the spindle of the lathe.

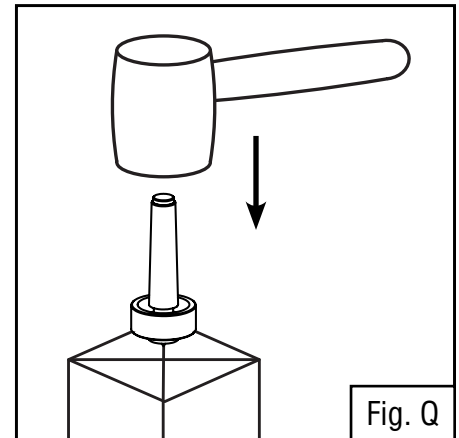

3. Clean the tapered end of the spur center and the inside of the headstock spindle. Insert the tapered end of the spur center (with the attached workpiece) into the headstock spindle. Support the workpiece while loosening the tailstock locking lever and bringing the tailstock into position. Tighten the tailstock locking lever to lock the tailstock to the bed.

4. Advance the tailstock quill with the hand wheel in order to seat the live center into the workpiece. Use enough pressure to secure the workpiece between the centers so that it won't fly off, but do not use excessive pressure. Excessive pressure runs the risk of overheating the center bearings and damaging both the workpiece and the lathe. Tighten the quill locking handle.

5. Adjust the position of the tool rest to be parallel to the workpiece. The tool rest height should be just below the centerline and approximately .1 to .2 inches (3 mm to 6 mm) from the corners of the workpiece to be turned. Secure the tool rest by tightening the tool rest locking handle and locking lever (Fig. R).

6. Before switching on the lathe, rotate the workpiece by hand to check for proper clearance.

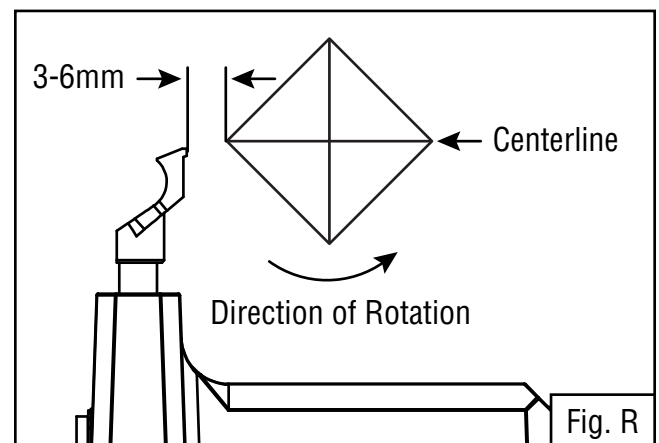

OPERATION

ROUGHING OUT

Begin with a large roughing gouge (see page 14 for examples of common cutting tools).

1. Place the tool on the tool rest with the heel of the tool on the surface to be cut. Slowly and gently raise the tool handle until the cutting edge comes into contact with the workpiece.
2. Beginning about 2 inches from the tailstock end of the workpiece, roll the flute of the tool (the hollowed-out portion) in the direction of the cut.
3. Make long sweeping cuts in a continuous motion to turn the piece to a cylinder. Keep as much of the bevel of the tool in contact with the workpiece as possible to ensure control and avoid catches.

NOTE: Always cut downhill, or from the large diameter to the small diameter. Always work towards the end of the workpiece; never start at the cutting end.

4. Once the workpiece is roughed down to a cylinder, smooth it with a large skew. Keep the skew handle perpendicular to the spindle and use only the center third of the cutting edge for a long smoothing cut (touching one of the points of the skew to the spinning workpiece may cause a catch and ruin the workpiece).

5. Add details to the workpiece with skews, parting tools, scrapers or spindle gouges.

CREATING BEADS

Make a parting cut for the desired depth and location of your bead.

1. Place the parting tool on the tool rest and move the tool forward to make the full bevel of the tool come into contact with the workpiece. Gently raise the handle to make cuts of the appropriate depth. Repeat for the other side of the bead.
2. Using a small skew or spindle gouge, start in the center between the two cuts and cut down each side to form the bead. Roll the tool in the direction of the cut.

CREATING COVES

Using a spindle gouge to create a cove.

1. With the flute of the tool at 90 degrees to the workpiece, touch the point of the tool to the workpiece and roll in towards the bottom of the cove. Stop at the bottom, as attempting to go up the opposite side may cause the tool to catch.
2. Move the tool over the desired width of the cove. With the flute facing the opposite direction, repeat the step for the other side of the cove. Stop at the bottom of the cut.

OPERATION

CREATING V-GROOVES

Using the point of the skew to create a V-groove in the workpiece.

1. Lightly mark the center of the V with the top of the skew. Move the point of the skew to the right half of the desired width of your cut.
2. With the bevel parallel to the right side of the cut, raise the handle and push the tool in to the desired depth. Repeat from the left side.

NOTE: The two cuts should meet at the bottom and leave a clean V-groove. Additional cuts may be taken to add to either the depth or the width of the cut.

PARTING OFF

Adjust the lathe to a slower speed for parting through a workpiece.

1. Place a parting tool on the tool rest and raise the handle until it starts to cut. Continue cutting towards the center of the workpiece.
2. Loosely hold on to the piece in one hand as it separates from the waste wood.

SANDING

NOTE: The cleaner the cuts, the less sanding will be required. To sand your workpiece:

1. Move away the tool rest and set the lathe to a low speed.
2. Use sandpaper finer than 120 grit, as coarse sandpaper may scratch the workpiece. Fold the sandpaper into a pad will allow easier and safer sanding. Do not wrap the sandpaper around your fingers or the workpiece.
3. Sand and progress through finer grits of sandpaper until the desired surface is achieved.

FINISHING

1. Turn off the lathe. The workpiece can be left on the lathe when applying finish.
2. Apply the finish using a brush or paper towel. Remove any excess finish before restarting the lathe.
3. Start the lathe at the lowest speed, as high speed may cause the fresh coat to splash. Allow the finish to dry and sand again with 320 to 400 grit sandpaper.
4. Apply a second coat of finish and buff the workpiece.

OPERATION

MOUNTING THE WORKPIECE ONTO THE FACE PLATE

The face plate is common for holding a block of wood of a larger diameter for turning bowls and plates.

1. Select a stock that is at least .2 inches (5 mm) larger than each dimension of the finished workpiece.
2. True one of the surfaces of the workpiece for mounting against the face plate. Using the face plate as a template, mark the location of the mounting holes on the workpiece and drill pilot holes of the appropriate size.
3. If the mounting screws on the face plate interfere with the workpiece, a glue or waste block can be used. Make sure the block is of the same diameter as the face plate. Both the waste block and the workpiece should have flat surfaces for gluing. Glue the block to the workpiece.

While face plates are the most reliable method for holding a larger block of wood for turning, chucks can also be used. A chuck is not a requirement, but is handy when working on more than one piece at a time. Rather than removing screws, simply open the chuck and change workpieces. The most popular ones are four jaw scroll chucks (dovetails) with a variety of jaws to accommodate different size tenons. Most also come with a screw chuck as well.

SHAPING THE OUTSIDE OF THE BOWL

1. Prepare the workpiece before mounting. Remove any bark from the top of the workpiece (that will be later attached onto a face plate or in a chuck).
2. Drive the spur center into the top center of the workpiece using a wood mallet or a dead blow hammer.
3. Insert the spur center into the headstock taper.
4. Insert the live center to the tailstock. Adjust the position of the tailstock along the bed and lock it into position. Lock the tailstock to the bed and advance the quill in order to seat the cut center into the workpiece. Tighten the quill locking handle.
5. Rotate the workpiece by hand to check for proper clearance before starting the tool. Start with the slowest speed for rough cuts and increase the speed for refined cuts.

NOTE: If the machine starts to vibrate, lower the speed until the vibration stops.

6. Rough out the outside of the bowl with the bowl gouge, holding the handle of the tool firmly against your hip.

As the bowl takes shape, work on the bottom (tailstock end) to accommodate attaching a face plate. Turn a short tenon to the size of the hole in the face plate. This will allow centering the workpiece when the face plate is attached. If you plan to use a chuck, turn a tenon of the appropriate length and diameter to fit your chuck.

Stop the lathe and remove the workpiece. Leave additional material at the base of the bowl for support while turning the interior. This will be removed later.

OPERATION

TO SHAPE THE INSIDE OF THE BOWL

Stop the lathe and move the tailstock away. Adjust the tool rest in front of the bowl just below the centerline at a right angle to the lathe's turning axis. Rotate the workpiece by hand to check for clearance.

Start by lightly shearing across the top of the workpiece from rim to center. Place a bowl gouge on the tool rest at the center of the workpiece with the flute facing the top of the bowl. The tool handle should be level and pointed toward the four o'clock position.

Use the left hand to control the cutting edge of the gouge, while the right hand swings the tool handle around towards your body. The flute should start out facing the top of the workpiece, rotating it upwards as it moves deeper into the bowl to maintain a clean and even curve. As the tool goes deeper into the bowl, progressively work outwards towards the rim of the bowl. It may be necessary to turn the tool rest into the piece as you get deeper into the bowl.

NOTE: Try to make one light continuous movement from the rim to the bottom of the bowl to ensure a clean, sweeping curve through the piece. Should there be a few small ridges left, a light cut with a large domed scraper can even out the surface.

Develop the preferred wall thickness at the rim and maintain it as you work deeper into the bowl (once the piece is thin toward the bottom, you cannot make it thinner at the rim). When the interior is finished, move the tool rest back to the exterior to re-define the bottom of the bowl. Work the tight area around the face plate or the chuck with a bowl gouge. Begin the separation with a parting tool, but do not cut all the way through.

MAINTENANCE

 **WARNING:** Disconnect the machine from the power source before making any maintenance or adjustments. Failure to do so may result in serious injury.

GENERAL MAINTENANCE

Keep your machine clean. At the end of each day, clean the machine. Wood contains moisture, meaning that sawdust and wood chips can cause rust if not removed. Regular oil attracts dust and dirt. Teflon lubricant tends to dry and has less of a tendency to accumulate dirt and saw dust. Periodically check that all nuts and bolts are tight.

DRIVE BELT

The drive belt should last for many years depending on usage, but it needs to be inspected regularly for cracks, cuts and general wear. If damage is found, replace the belt before operation.

BEARINGS

All bearings are sealed for life and don't require any maintenance. If bearing becomes faulty, replace it.

RUST

The lathe is made from steel and cast iron. All non-painted surfaces will rust if not protected. It is recommended that they are protected by applying a light coat of good-quality paste wax to the surfaces to guard against rust and corrosion.

EXPLODED VIEW & PARTS LIST

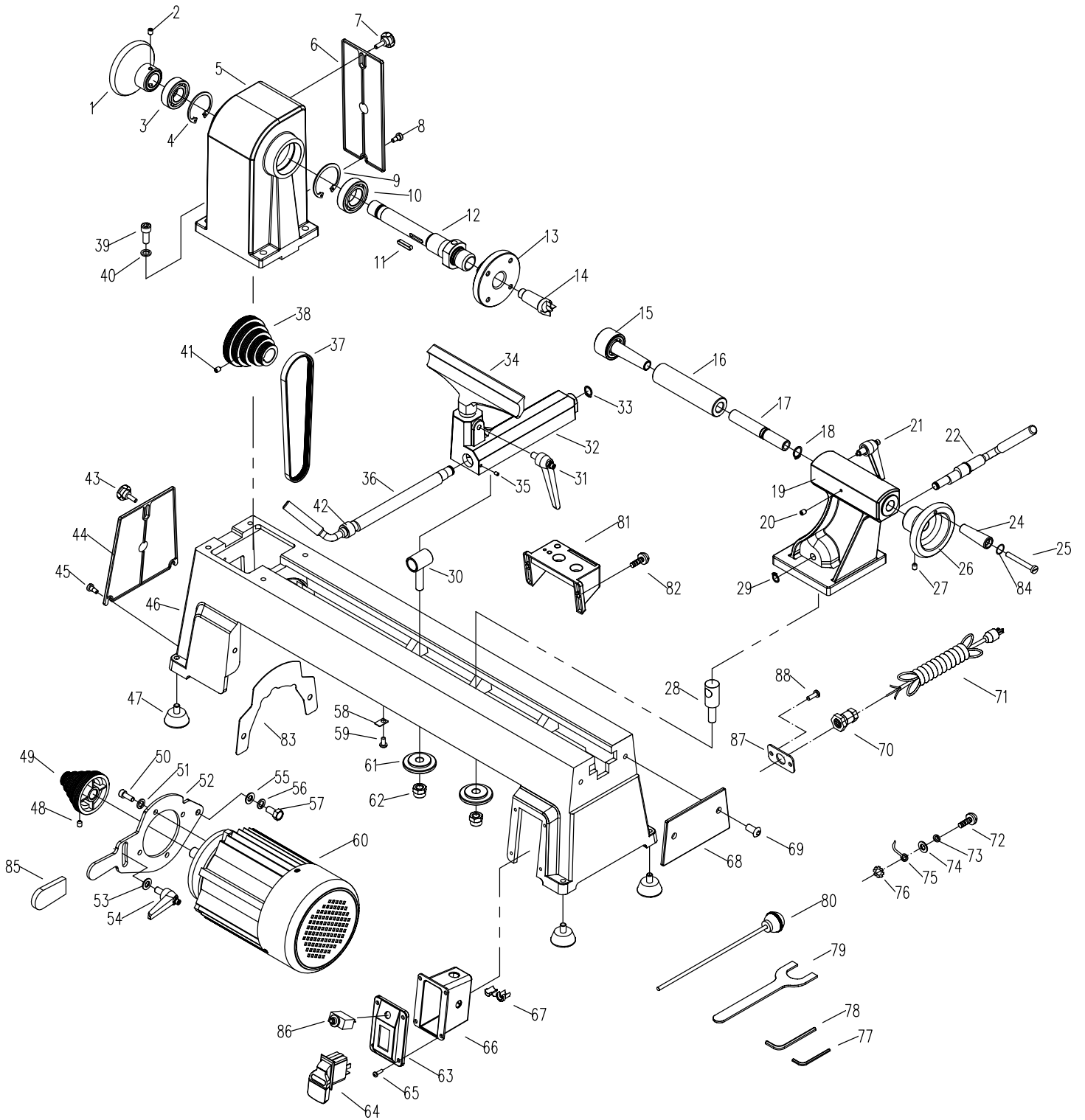

EXPLODED VIEW & PARTS LIST

No.	Part No.	Description	Qty.
1	3424-001	Rear Spindle Wheel	1
2	3424-002	Set Screw	2
3	3424-003	Ball Bearing, 6004ZZ	1
4	3424-004	Retaining Ring	1
5	3424-005	Headstock	1
6	3424-006	Rear Cover	1
7	3424-007	Rear Cover Locking Knob	1
8	3424-008	Screw, M6x16	1
9	3424-009	Retaining Ring	1
10	3424-010	Ball Bearing, 6005ZZ	1
11	3424-011	Key	1
12	3424-012	Spindle Shaft	1
13	3424-013	Face Plate	1
14	3424-014	Spur Center	1
15	3424-015	Live Center	1
16	3424-016	Quill	1
17	3424-017	Screw Stem	1
18	3424-018	Retaining Ring	1
19	3424-019	Tailstock	1
20	3424-020	Set Screw	1
21	3424-021	Quill Locking Handle	1
22	3424-022	Tailstock Locking Lever	1
24	3424-024	Handle	1
25	3424-025	Handle Screw	1
26	3424-026	Handwheel	1
27	3424-027	Set Screw	2
28	3424-028	Tailstock Drawbar	1
29	3424-029	Retaining Ring	1
30	3424-030	Tool Rest Drawbar	1
31	3424-031	Tool Rest Locking Handle	1
32	3424-032-1	Tool Rest Base	1
33	3424-033	Retaining Ring	1
34	3424-034-1	Tool Rest	1
35	3424-035	Set Screw	1
36	3424-036	Tool Rest Locking Lever	1
37	3424-037	Drive Belt	1

No.	Part No.	Description	Qty.
38	3424-038	Spindle Pulley	1
39	3424-039	Headstock Mounting Screw	1
40	3424-040	Lock Washer	4
41	3424-041	Set Screw	1
42	3424-042	Bushing	1
43	3424-043	Side Cover Locking Knob	1
44	3424-044	Side Cover	1
45	3424-045	Screw, M6x16	2
46	3424-046-1	Base	1
47	3424-047	Threaded Foot, M8-1.25	4
48	3424-048	Set Screw	2
49	3424-049	Motor Pulley	1
50	3424-050	Motor Mounting Screw	4
51	3424-051	Lock Washer	4
52	3424-052	Motor Support Plate	1
53	3424-053	Flat Washer	1
54	3424-054	Motor Plate Lock Handle	1
55	3424-055	Flat Washer	1
56	3424-056	Lock Washer	1
57	3424-057	Hex Head Bolt	1
58	3424-058	Cord Clamp	3
59	3424-059	Pan Head Screw, M5x10	3
60	3424-060	Motor	1
61	3424-061	Clamp Plate	1
62	3424-062	Nut, M10	1
63	3424-063-1	Switch Plate	1
64	3424-064	Switch	1
65	3424-065-1	Pan Head Screw, M5x12	4
66	3424-066-1	Switch Housing	1
67	3424-067	Bushing	2
68	3424-068	End Stop Plate	1
69	3424-069	Pan Head Screw, M8x12	2

EXPLODED VIEW & PARTS LIST

No.	Part No.	Description	Qty.
70	3424-070	Strain Relief	1
71	3424-071	Power Cord	1
72	3424-072	Pan Head Screw, M5x10	2
73	3424-073	Lock Washer, 5mm	2
74	3424-074	Flat Washer, 5mm	2
75	3424-075	Grounding Terminal	2
76	3424-076	Serrated Washer	2
77	3424-077	3mm Hex Wrench	1
78	3424-078	5mm Hex Wrench	1
79	3424-079	Face Plate Wrench	1
80	3424-080	Knockout Rod	1

No.	Part No.	Description	Qty.
81	3424-081	Tool Holder	1
82	3424-082	Pan Head Screw, M5x12	2
83	3424-083	Sealing Plate	1
84	3424-084	Rubber Ring	1
85	3424-085	Handle Cover	1
86	3424-086	Circuit Breaker, 5A	1
87	3424-087	Bushing Mounting Plate	1
88	3424-088	Pan Head Screw, M5x12	2

TROUBLESHOOTING GUIDE

⚠ WARNING: Stop using the tool immediately if any of the following problems occur. Repairs and replacements should only be performed by an authorized technician. For any questions, please contact our customer service at (800) 232-1195, M-F 8-5 CST or email us at techsupport@wenproducts.com.

PROBLEM	CAUSE	SOLUTION
Motor will not start	Power cord damaged or not properly plugged in.	Check the power cord, extension cord, power plug and the power outlet. Do not use the tool if any cord is damaged.
	Defective power switch.	Stop using the tool and contact customer service at 1-(800) 232-1195 , M-F 8-5 CST for assistance.
	Defective motor or other internal damage.	Stop using the tool and contact customer service at 1-(800) 232-1195 , M-F 8-5 CST for assistance.
	Circuit breaker is tripped.	Push breaker to reset.
Motor or spindle stalls	Excessive cut	Reduce the depth of the cut
	Worn, damaged, or improperly adjusted drive belt	Adjust or replace the drive belt (Part No. 3424-037).
	Worn spindle bearing	Replace the bearing.
Excessive vibration.	Workpiece is warped, out of round, has major flaw, or was improperly prepared for turning.	Correct the problem by planing or sawing workpiece, or discard it entirely and restart.
	Worn spindle bearing.	Replace the spindle bearings .
	Worn drive belt.	Replace the drive belt (Part No. 3424-037).
	Lathe is on an uneven surface.	Place the lathe on a flat surface.
Tools tend to grab or dig in.	Dull tools.	Use sharp tools.
	Tool rest set too low.	Reposition the tool rest height (see page 11).
	Tool rest set too far from work piece.	Reposition the tool rest closer to the work-piece (see page 11).
	Improper tool being used.	Use correct tool for operation (see page 12).
Tailstock moves when locked and pressure is applied.	Cam lock nut needs adjusting.	Tighten cam lock nut.
	Lathe bed and tailstock mating surfaces are greasy or oily.	Remove the tailstock and clean the surfaces with a cleaner. Apply a light coat of oil to the lathe bed surface.

WARRANTY STATEMENT

WEN Products is committed to building tools that are dependable for years. Our warranties are consistent with this commitment and our dedication to quality.

LIMITED WARRANTY OF WEN PRODUCTS FOR HOME USE

GREAT LAKES TECHNOLOGIES, LLC (“Seller”) warrants to the original purchaser only, that all WEN consumer power tools will be free from defects in material or workmanship during personal use for a period of two (2) years from date of purchase or 500 hours of use; whichever comes first. Ninety days for all WEN products if the tool is used for professional or commercial use. Purchaser has 30 days from the date of purchase to report missing or damaged parts.

SELLER’S SOLE OBLIGATION AND YOUR EXCLUSIVE REMEDY under this Limited Warranty and, to the extent permitted by law, any warranty or condition implied by law, shall be the replacement of parts, without charge, which are defective in material or workmanship and which have not been subjected to misuse, alteration, careless handling, misrepair, abuse, neglect, normal wear and tear, improper maintenance, or other conditions adversely affecting the Product or the component of the Product, whether by accident or intentionally, by persons other than Seller. To make a claim under this Limited Warranty, you must make sure to keep a copy of your proof of purchase that clearly defines the Date of Purchase (month and year) and the Place of Purchase. Place of Purchase must be a direct vendor of Great Lakes Technologies, LLC. Purchasing through third party vendors, including but not limited to garage sales, pawn shops, resale shops, or any other secondhand merchant, voids the warranty included with this product. Contact techsupport@wenproducts.com or 1-800-232-1195 with the following information to make arrangements: your shipping address, phone number, serial number, required part numbers, and proof of purchase. Damaged or defective parts and products may need to be sent to WEN before the replacements can be shipped out.

Upon the confirmation of a WEN representative, your product may qualify for repairs and service work. When returning a product for warranty service, the shipping charges must be prepaid by the purchaser. The product must be shipped in its original container (or an equivalent), properly packed to withstand the hazards of shipment. The product must be fully insured with a copy of the proof of purchase enclosed. There must also be a description of the problem in order to help our repairs department diagnose and fix the issue. Repairs will be made and the product will be returned and shipped back to the purchaser at no charge for addresses within the contiguous United States.

THIS LIMITED WARRANTY DOES NOT APPLY TO ITEMS THAT WEAR OUT FROM REGULAR USAGE OVER TIME, INCLUDING BELTS, BRUSHES, BLADES, BATTERIES, ETC. ANY IMPLIED WARRANTIES SHALL BE LIMITED IN DURATION TO TWO (2) YEARS FROM DATE OF PURCHASE. SOME STATES IN THE U.S. AND SOME CANADIAN PROVINCES DO NOT ALLOW LIMITATIONS ON HOW LONG AN IMPLIED WARRANTY LASTS, SO THE ABOVE LIMITATION MAY NOT APPLY TO YOU.

IN NO EVENT SHALL SELLER BE LIABLE FOR ANY INCIDENTAL OR CONSEQUENTIAL DAMAGES (INCLUDING BUT NOT LIMITED TO LIABILITY FOR LOSS OF PROFITS) ARISING FROM THE SALE OR USE OF THIS PRODUCT. SOME STATES IN THE U.S. AND SOME CANADIAN PROVINCES DO NOT ALLOW THE EXCLUSION OR LIMITATION OF INCIDENTAL OR CONSEQUENTIAL DAMAGES, SO THE ABOVE LIMITATION OR EXCLUSION MAY NOT APPLY TO YOU.

THIS LIMITED WARRANTY GIVES YOU SPECIFIC LEGAL RIGHTS, AND YOU MAY ALSO HAVE OTHER RIGHTS WHICH VARY FROM STATE TO STATE IN THE U.S., PROVINCE TO PROVINCE IN CANADA AND FROM COUNTRY TO COUNTRY.

THIS LIMITED WARRANTY APPLIES ONLY TO ITEMS SOLD WITHIN THE UNITED STATES OF AMERICA, CANADA AND THE COMMONWEALTH OF PUERTO RICO. FOR WARRANTY COVERAGE WITHIN OTHER COUNTRIES, CONTACT THE WEN CUSTOMER SUPPORT LINE. FOR WARRANTY PARTS OR PRODUCTS REPAIRED UNDER WARRANTY SHIPPING TO ADDRESSES OUTSIDE OF THE CONTIGUOUS UNITED STATES, ADDITIONAL SHIPPING CHARGES MAY APPLY.