

Foundation Kit

Instructions for Assembly Size 8' x 6'

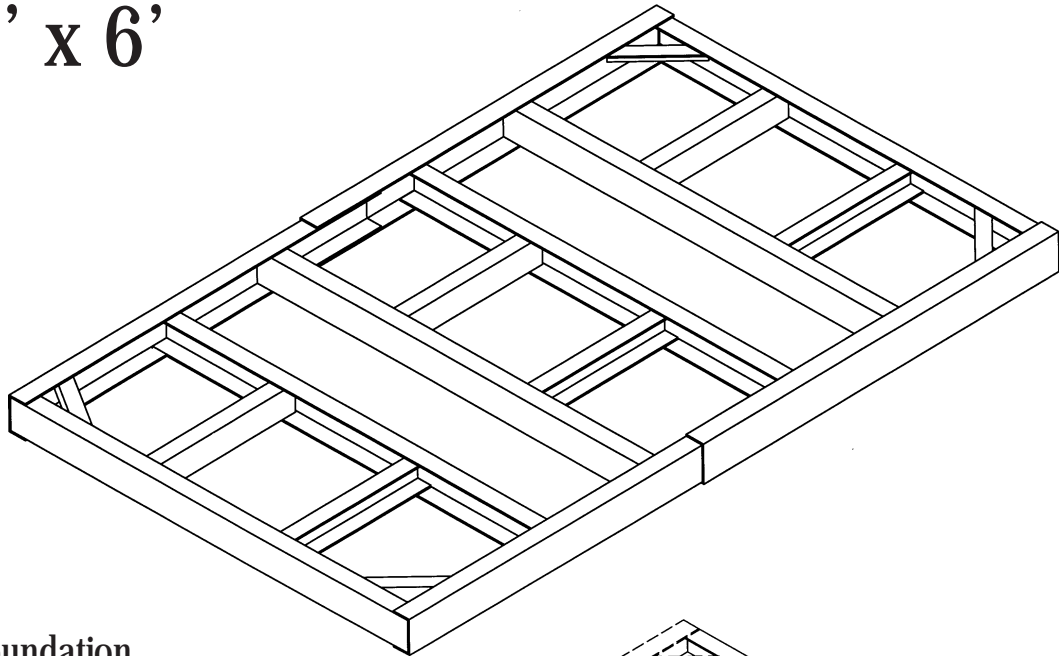

PART 1 :
8' x 6' Foundation
Assembly Instruction

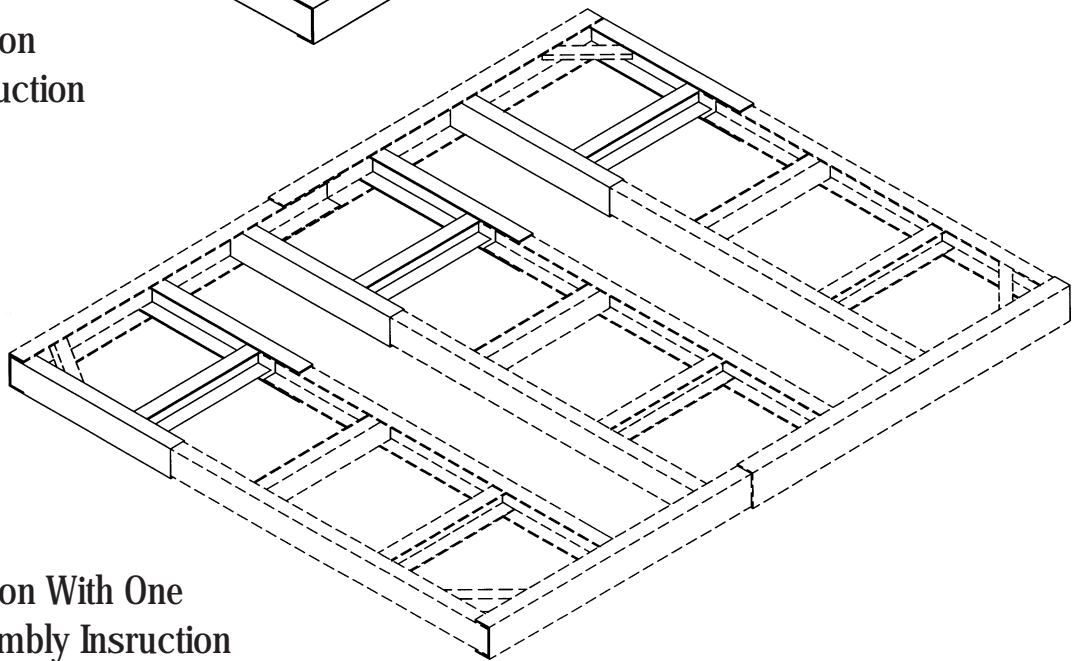

PART 2 :
8' x 6' Foundation With One
Extension Assembly Instruction

TOOLS YOU WILL NEED

- Cordless Drill - Philips Head

PART 1 : 8' x 6' Foundation Assembly

1. Assemble the channel (F01B) & (F02B) together using 4 screws. Make 2 sets.

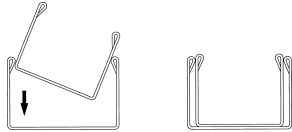
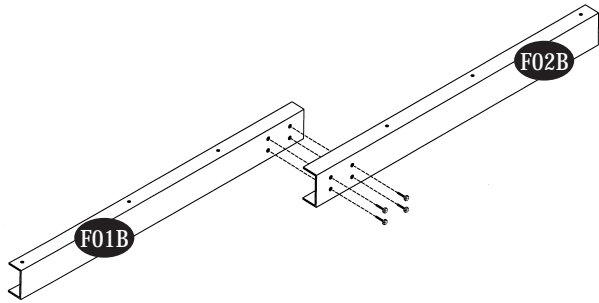

Parts List

Note: Check all parts prior to installation.

CODE	DESCRIPTION	QTY
F01B	FOUNDATION 'U' CHANNEL	2
F02B	FOUNDATION 'U' CHANNEL	2
F03	FOUNDATION 'L' ANGLE	4
F04B	FOUNDATION 'U' CHANNEL	6
F05B	FOUNDATION 'U' CHANNEL	6

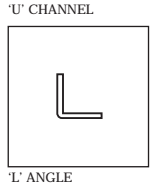
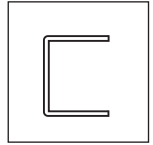

ACCESSORIES

CODE	DESCRIPTION	QTY
S1	DIA. 4.2 x 16mm. (5/32" x 5/8") SHEET METAL SCREW	64

2. Make a frame with the sub assemblies as shown below.



Make sure while assembling, the channel position should be as shown.

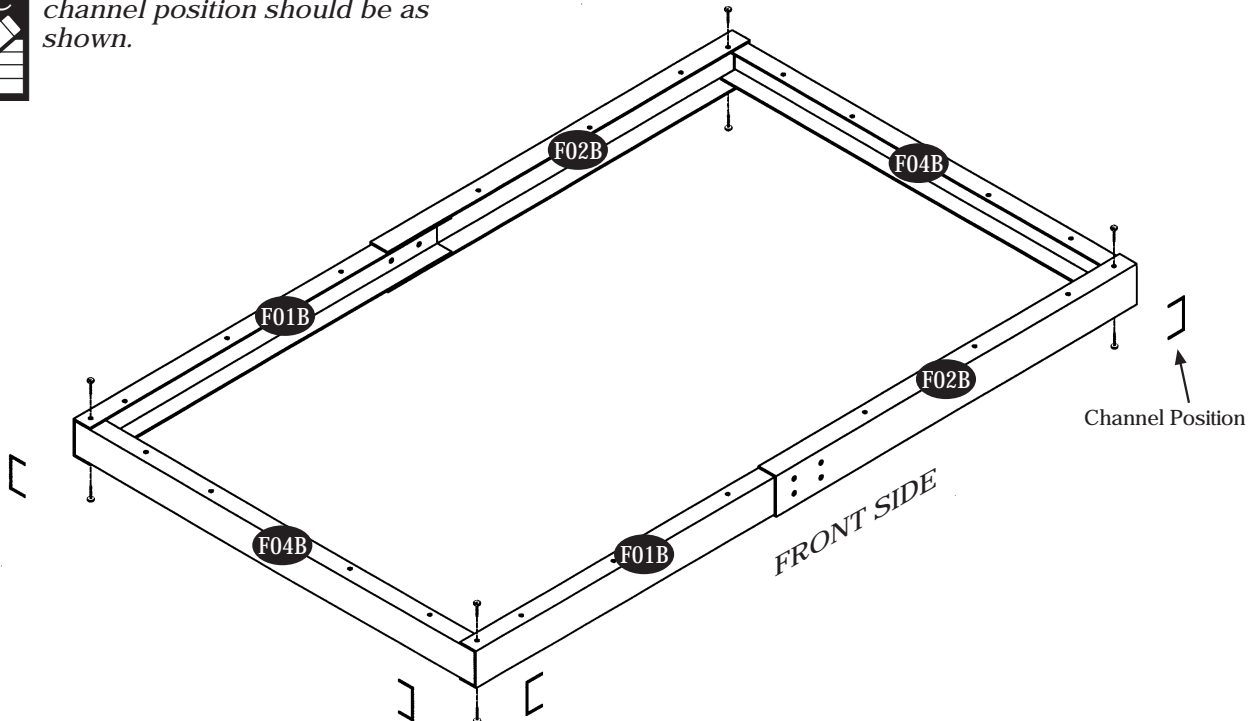

3. Fix the L-angle (F03) to the channel at all the four corners to make a perfect frame. See Fig.

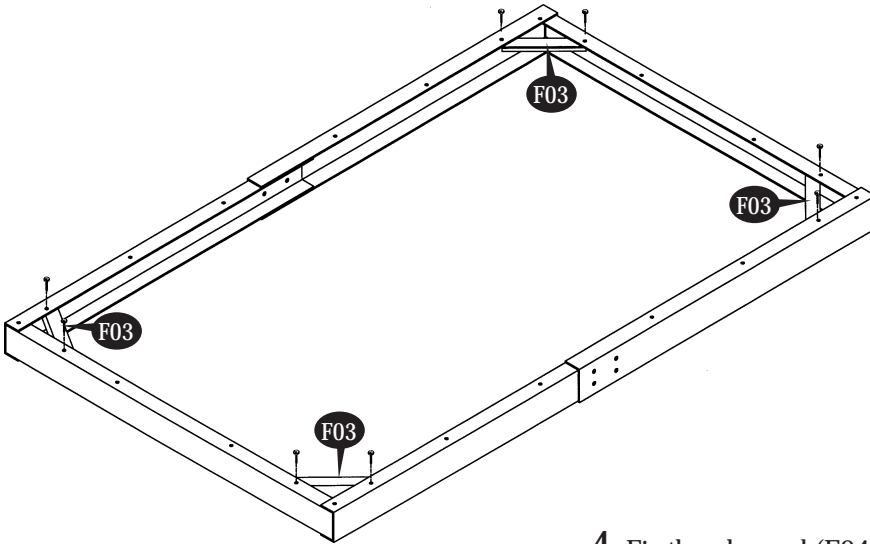

4. Fix the channel (F04B) into the main frame as shown. See Fig.

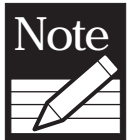

Make sure while assembling, the channel position should be as shown.

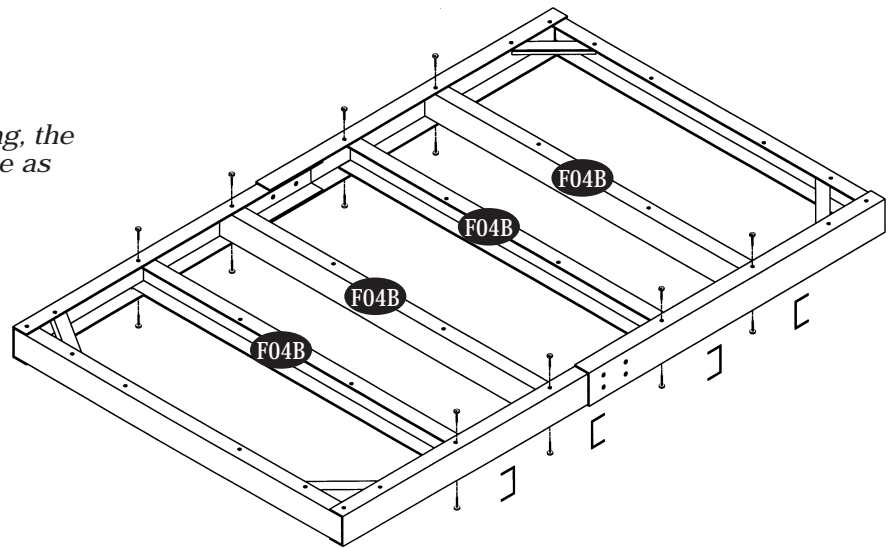

5. Fix the channel (F05B) into the frame with screws as shown. See Fig.

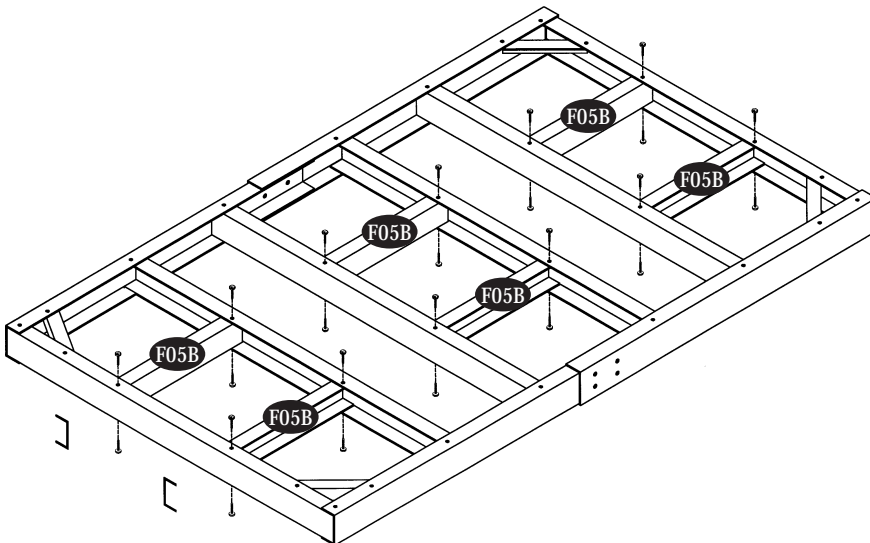

6. Assemble the U-Channel bases on top of the foundation as shown in Figure.

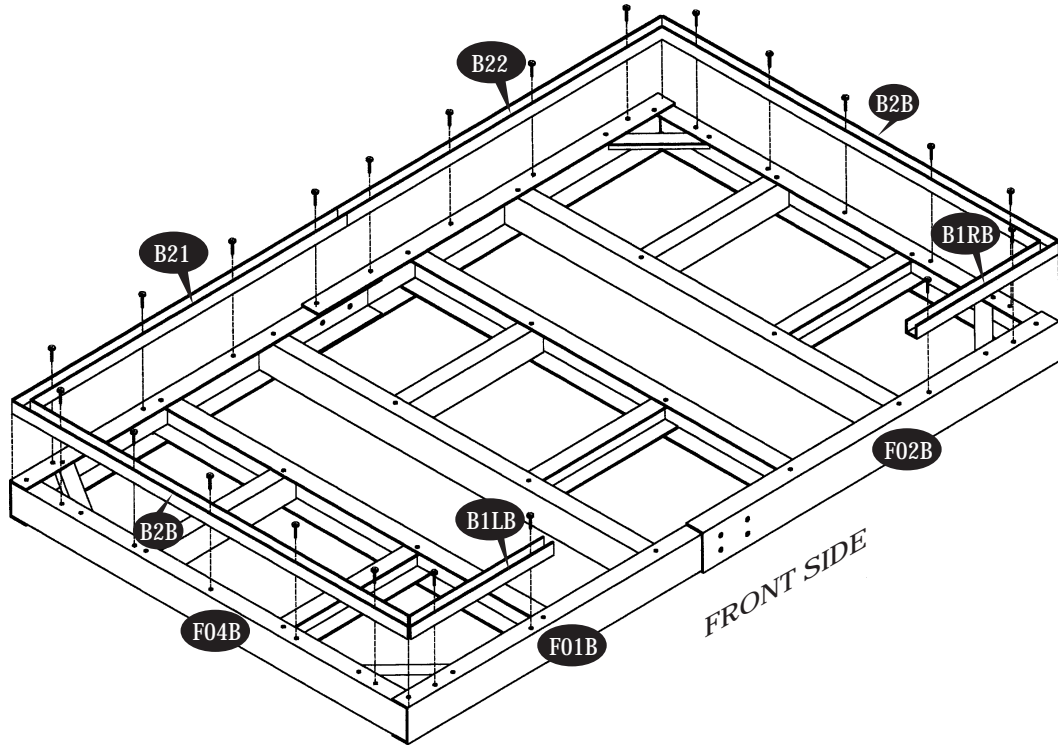

7a. After completing the assembly of shed place exterior grade CDX 3/4" (19mm) plywood inside the foundation. See fig.

OR 7b. After completing the assembly of the base U-channel fill the concrete upto the foundation top surface.

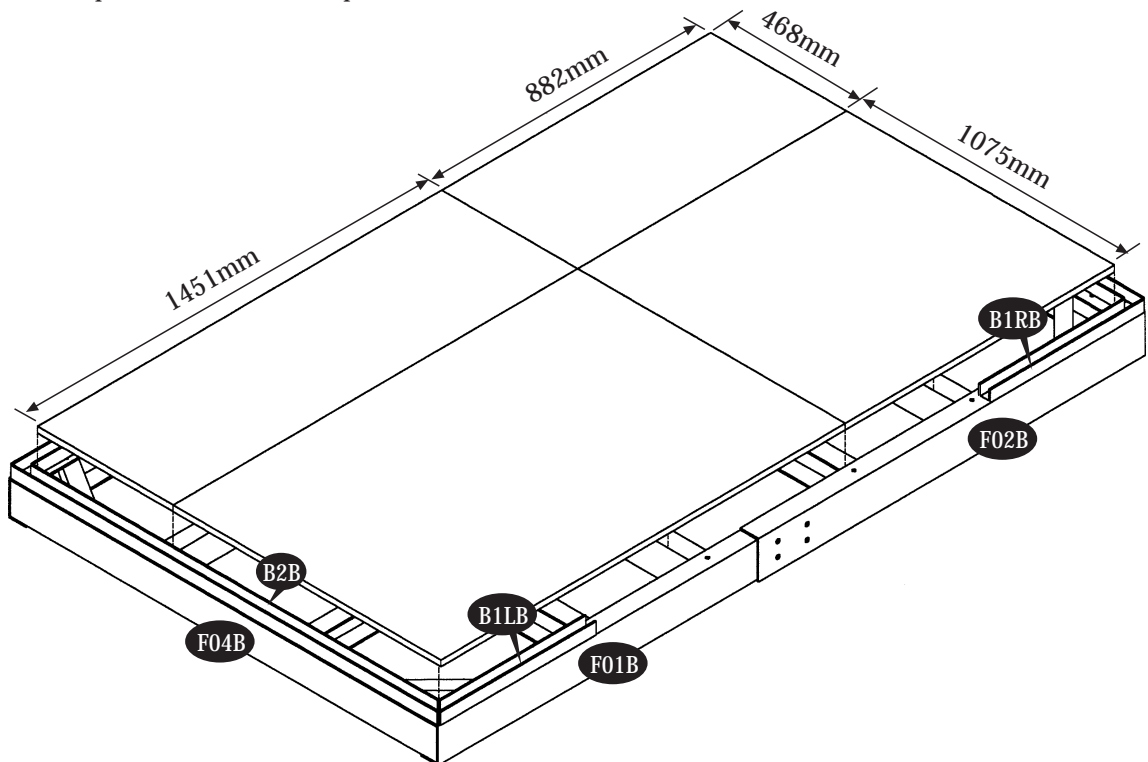

PART 2 : 8' x 6' Foundation With One Extension Assembly

1. Assemble the channel (F01B) & (F02B) together using 4 screws. Make 2 sets.

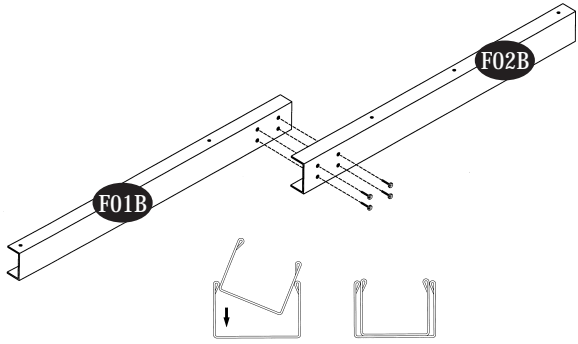

Parts List

Note: Check all parts prior to installation.

CODE	DESCRIPTION	QTY
F05B	FOUNDATION 'U' CHANNEL	3
F07	FOUNDATION 'U' CHANNEL	6

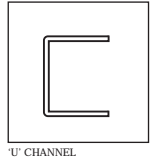

2. Assemble the channel (F04B) & Extension (F07) together with screws. Make 6 sets.

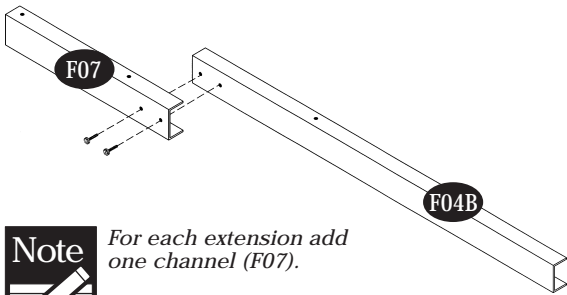

ACCESSORIES

CODE	DESCRIPTION	QTY
S1	DIA. 4.2 x 16mm. (5/32" x 5/8") SHEET METAL SCREW	24



Note For each extension add one channel (F07).

3. Make a frame with the sub assemblies as shown below.

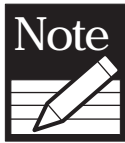

Note Make sure while assembling, the channel position should be as shown.

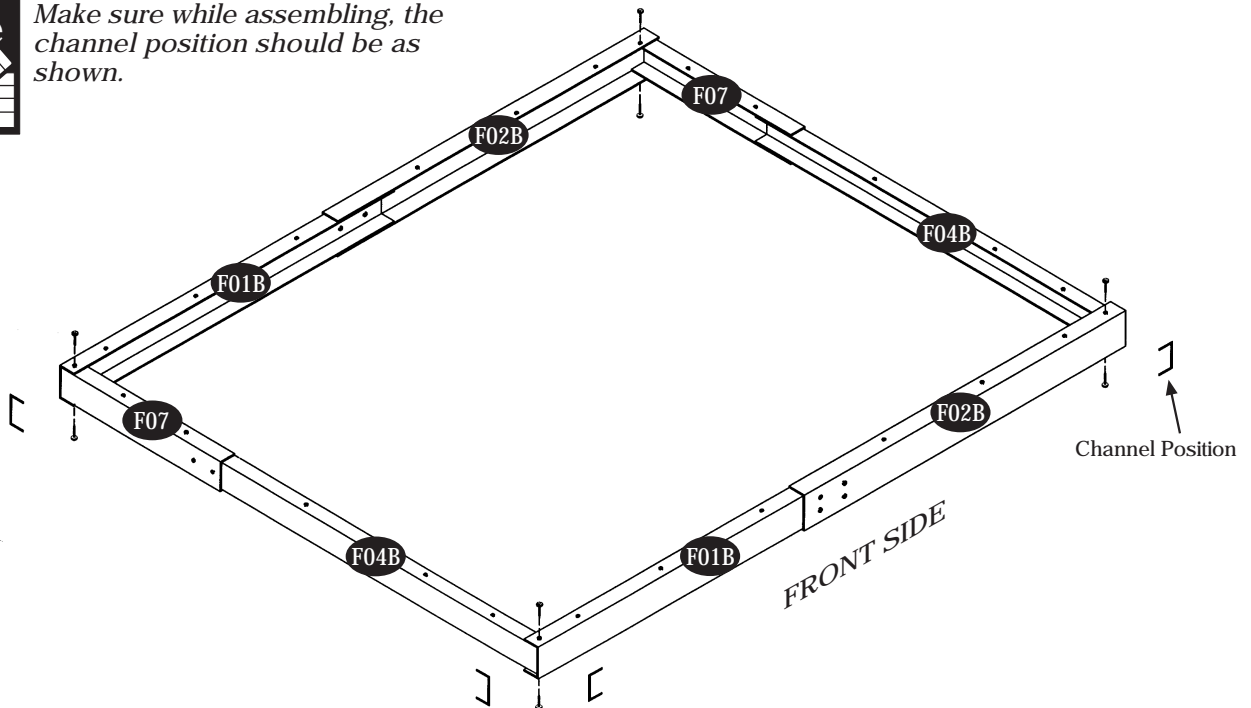

4. Fix the L-angle (F03) to the channel at all the four corners to make a perfect frame. See Fig.

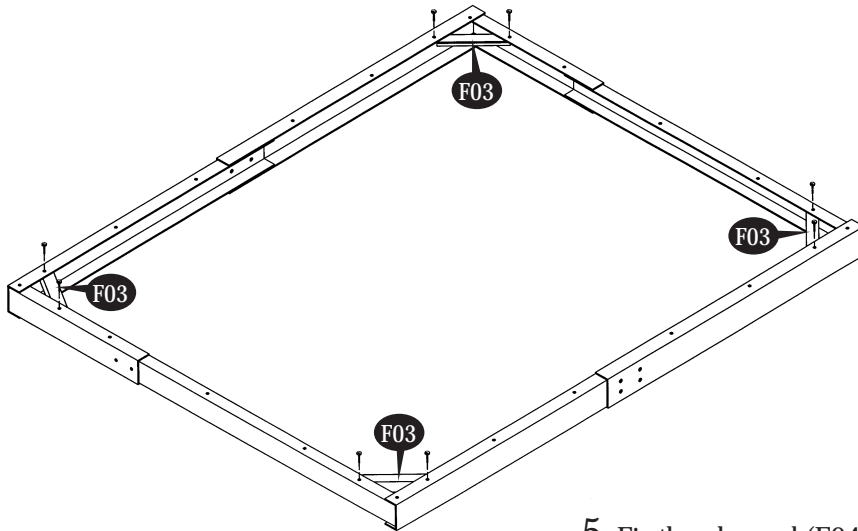

5. Fix the channel (F04B) & (F07) sub assembly into the main frame as shown. See Fig.

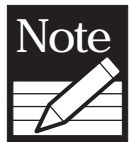

Make sure while assembling, the channel position should be as shown.

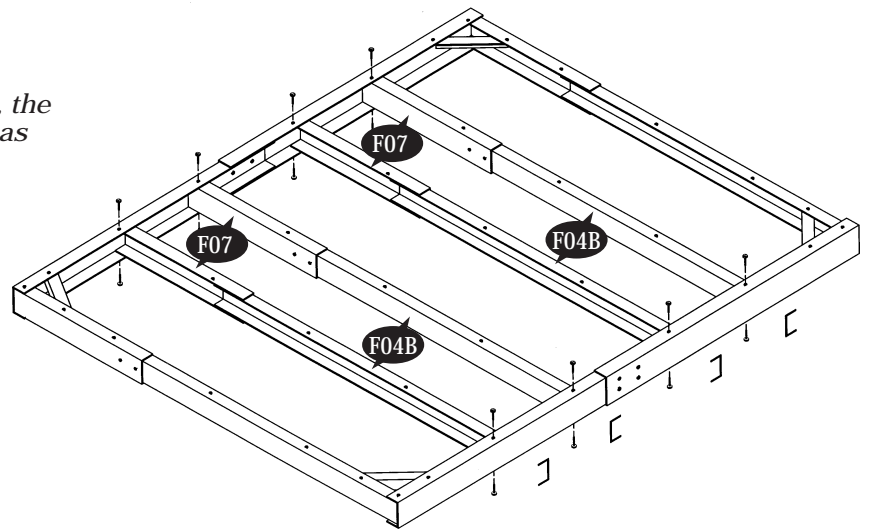

6. Fix the channel (F05B) into the frame with screws as shown. See Fig.

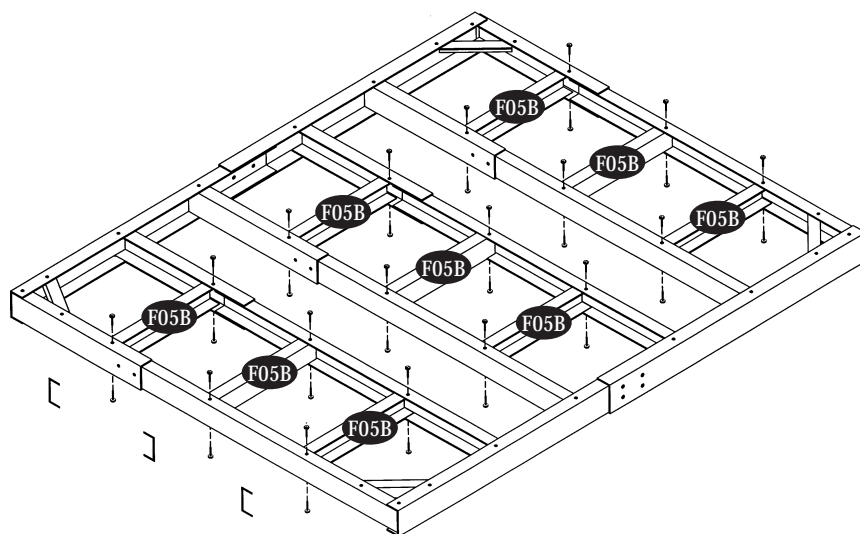

7. Assemble the U-Channel bases on top of the foundation as shown in Figure.

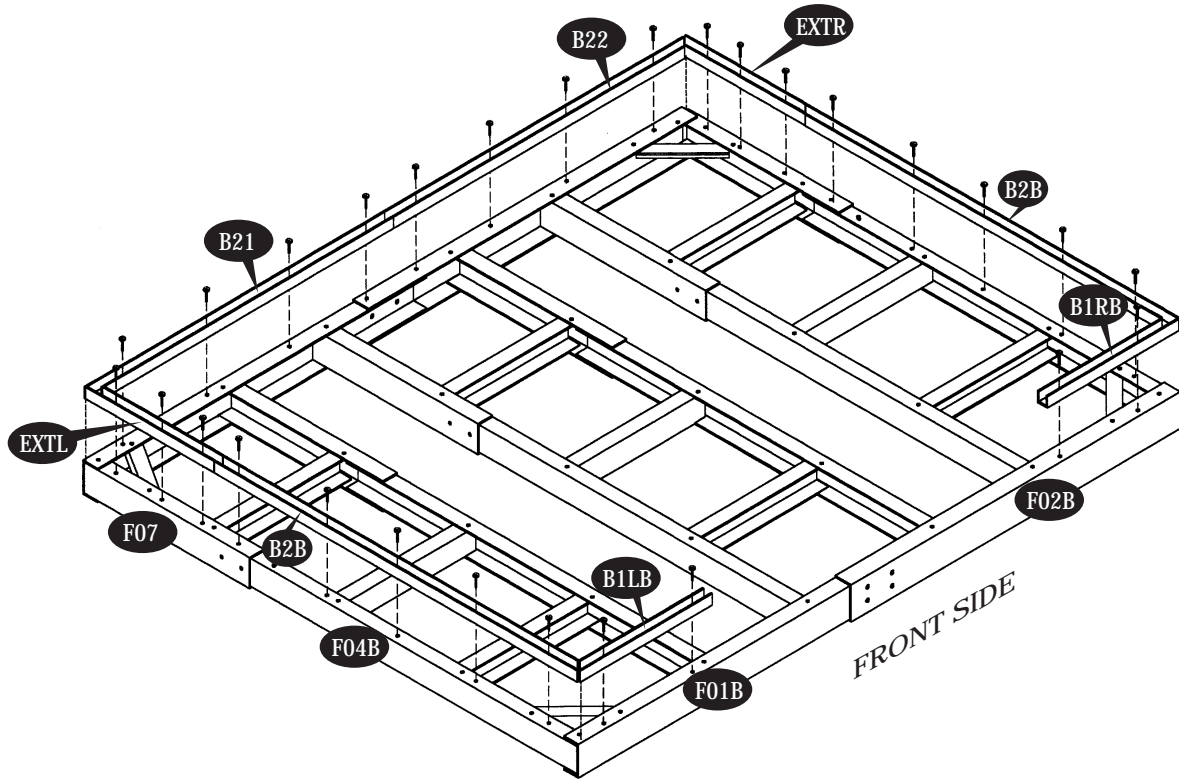

8a. After completing the assembly of shed place exterior grade CDX 3/4" (19mm) plywood inside the foundation. See fig.

OR 8b. After completing the assembly of the base U-channel fill the concrete upto the foundation top surface.

