



Advanced Reverse Osmosis Water Filtration System

Installation and Operating Instructions

Models RO-3000 and RO-3500 (with electronic TDS monitor)

Operating Specifications

IMPORTANT! Before installing this reverse osmosis system, make certain your water supply complies with the following operating specifications. Failure to do so may reduce the effectiveness of the system and will void the warranty. Consult your local water treatment utility or a certified water testing lab to determine the quality of your water and use the table below to record your results for future reference.

RO-3000/RO-3500 Operating Specifications		YOUR WATER
Pressure Range	40-100 psi (2.8-6.89 bar)	_____
Temperature Range	40-100°F (4.4-37.8°C)	_____
Total Dissolved Solids	less than 1500 ppm	_____
Maximum Hardness*†	10 gpg (171 mg/l)	_____
Sulfide, Iron and Manganese†	less than 0.01 ppm	_____
Chlorine In Water Supply	less than 2 ppm	_____
Water Supply pH Limits	4-11	_____
Turbidity	1 NTU Max.	_____
MODEL #: _____		
DATE OF PURCHASE: _____		

* **IMPORTANT!** If the hardness of your water is above 10 gpg (171mg/L), lime scale will build up rapidly on the membrane. Scale buildup will plug the membrane and make the system ineffective. We do not recommend these reverse osmosis systems be used with water in excess of 10 gpg (171 mg/L) hardness, unless the water is softened prior to the reverse osmosis system.

† See your local dealer or water treatment specialist to reduce these substances in your water.

NOTE: If your water pressure and temperature are at the low end of the listed range (40 psi [2.8 bar] and 40°F [4.4°C]), and the TDS level is near the maximum (1500 ppm), the system will not function properly. Under these extreme conditions, pre-warming the supply water using a 25-ft. (7.62 m) coil of tubing between the saddle valve and the system, and/or installing a booster pump to increase the water pressure will allow the system to perform effectively.

WARNING: Do not use with water that is microbiologically unsafe or of unknown quality without adequate disinfection before or after the system. Systems certified for cyst reduction may be used on disinfected waters that may contain filterable cysts.

NOTE: Substances reduced are not necessarily in your water. System must be maintained according to manufacturer's instructions, including replacement of filter cartridges.

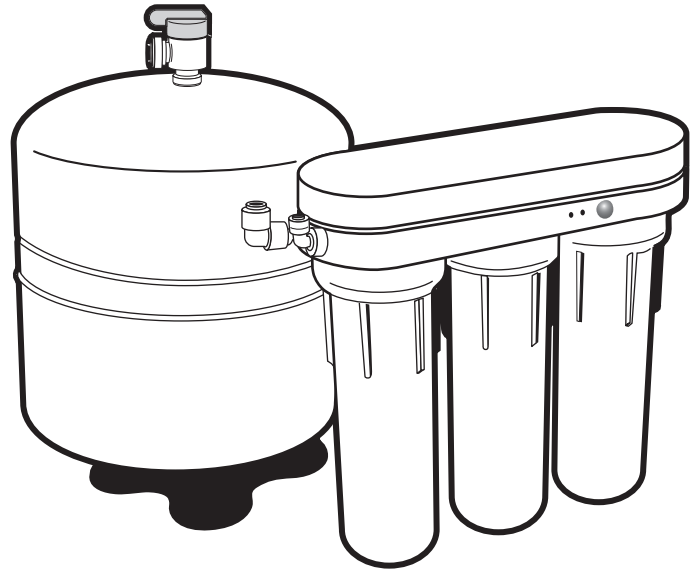

System Dimensions

System Dimensions	13.75"w x 4.75"d x 12.75"h (349 mm x 121 mm x 318 mm)
System Weight	6.1 lbs. (2.7 kg)
Tank Dimensions	11.3"d x 16.75"h (287 mm x 425 mm) (with valve)
Tank Capacity	1.9-3.2 gal. (7.2-12.1L) (Depending on water pressure)
Tank Weight (full)	40 lbs. (18.2 kg.) (Depending on water pressure)

Production Capabilities

* Tested by NSF International according to NSF/ANSI Standard 58 has given 7.6 gallons per day. Source water test parameters are 50 psig, 77°F, pH of 7.5 ± 0.5 and 750ppm total dissolved solids.

Tools and Materials Required

- Hand or Electric Drill (Cordless Recommended)
 - Phillips Screwdrivers
 - (2) Adjustable Wrenches
 - Drill bits: 1/8, 1/4, & 3/8-inch
 - File
 - Safety Glasses
 - Utility knife or tube cutter
 - Needle-nose pliers
 - Measuring tape
- If sink does not have hole for separate faucet:
- Center Punch
 - 1½-Inch Bi-metal or Carbide-Tipped Hole Saw
 - Respirator

NOTE: Not all tools may be necessary for installation. Read installation procedures before starting to determine if additional tools are necessary.



The RO-3000 is Tested and Certified by NSF International against NSF/ANSI Standard 58 for the reduction of Total Dissolved Solids, Fluoride, Turbidity, Lead, Selenium, Copper and Cysts.



The RO-3500 is Tested and Certified by NSF International against NSF/ANSI Standard 58 for the reduction of Total Dissolved Solids, Fluoride, Turbidity, Nitrate/Nitrite, Lead, Selenium, Pentavalent Arsenic, Copper, Cadmium, Hexavalent Chromium, Trivalent Chromium, Barium, Cysts and Radium 226/228.

General Precautions

WARNING: The RO-3000 and RO-3500 systems contain a replaceable membrane critical to the efficiency of the system. Replacement of the reverse osmosis membrane should be with one of identical specifications, as defined by the manufacturer, to assure the same efficiency and contaminant reduction performance.

WARNING: The RO-3000 and RO-3500 systems contain a replaceable membrane, critical for the effective reduction of total dissolved solids. Product water should be tested periodically to verify that the system is working properly.

WARNING: The RO-3500 is acceptable for treatment of influent concentrations of no more than 27 mg/L nitrate and 3 mg/L nitrite in combination measured as N and is certified for nitrate/nitrite reduction only for water supplies with a pressure of 40 psig (280 kPa) or greater.

WARNING: The RO-3500 shall only be used for arsenic reduction on chlorinated water supplies containing detectable residual free chlorine at the system inlet. Water systems using an in-line chlorinator should provide a one-minute chlorine contact time before the RO system.

WARNING: The Reverse Osmosis (RO) system will not protect against disease-causing bacteria or remove naturally-occurring harmless bacteria.

CAUTION: The RO-3000 and RO-3500 systems must be protected against freezing which can cause the filter housing to crack and water leakage.

CAUTION: Because of the product's limited service life and to prevent costly repairs or possible water damage, we strongly recommend that the filter housings be replaced every ten years. If your housing has been in use for longer than this period, it should be replaced immediately.
Date the bottom of any new filter housing to recommend the next replacement date.

CAUTION: Do not use Plumber's Putty in the installation of this product as it may cause cracking of the filter housing threads.

NOTE:

- Your water must be within required limits for satisfactory operation. If not, your membrane life may be shortened and your warranty will be voided (see Operating Specifications on page 1).
- Install on cold water line only.
- Make certain that installation complies with all state and local laws and regulations.
- The reverse osmosis membrane and replacement cartridges included with this system have limited service lives. Changes in taste, odor, and color of the filtered water indicate that the cartridge(s) and/or membrane should be replaced (see Maintenance on page 10). On the monitored model (RO-3500) the green light indicates optimum performance while the amber light indicates that the membrane is in need of changing.
- During extended periods of non-use (such as during a vacation), remove the membrane from the membrane housing and place it in a sealed plastic bag. Store membrane in refrigerator for future use. **DO NOT FREEZE.**
- If system stands for more than 2 to 3 days without being used, the storage tank should be emptied.

Membrane Precautions

CAUTION: Chlorine will destroy the Reverse Osmosis membrane. If you use these RO systems with a chlorinated or periodically-chlorinated water supply, it is **ABSOLUTELY NECESSARY** to use a carbon pre-filter (such as the **USL-NCR** cartridge, included with the system). This carbon pre-filter should be changed at least every 4 months to avoid chlorine breakthrough. See warranty for disclaimers and limitations that apply to the RO membrane.

NOTE: To make sure no chlorine is present in the water that reaches the membrane, you may want to use a chlorine test kit to check the reject water that flows from the membrane to the drain. No chlorine should be detected.

How Reverse Osmosis Works

The Pentek RO-3000 and RO-3500 use a semi-permeable membrane to reduce dissolved salts, improving the taste and odor of your water. The RO membrane is made of multiple layers of micron-thin film wound around a hollow center core. Water molecules can pass through the membrane, while dissolved salts are rejected. The Pentek RO-3000 and RO-3500 systems feature triple-filter action. Your household water supply is pre-filtered to reduce dirt and chlorine that may foul the membrane. The RO membrane separates this pre-filtered water into **PRODUCT WATER** and **REJECT WATER**. Your household water pressure forces the product water through the membrane and into the storage tank. Dissolved salts cannot pass through the membrane and are sent to the drain as reject water. When you open the RO faucet, product water is drawn from the storage tank through a post-polishing filter. The post-polishing filter takes out any remaining taste or odor in the water and provides you and your family with cleaner, great-tasting water.

The RO-3000 and RO-3500 systems also feature an auto shut-off valve, which shuts off the system once the pressure in the storage tank reaches 2/3 of the incoming water pressure (your household water pressure). When you open the faucet to draw water from the storage tank, the pressure inside the tank drops and the auto shut-off valve opens. The system then begins to operate, replenishing the water you took from the storage tank. For each gallon of water produced, 7 gallons are discharged as reject water. The storage tank can hold up to 3.2 gallons of water at a time, more than enough for the average family's drinking and cooking needs.

When used under operating conditions specified on page 1 of the manual, your Reverse Osmosis membranes should last 12-24 months.

NOTE: The RO-3500 unit will indicate a need for a membrane change with an amber light, see Light Indicator Readings on page 9 for details.

The precise life span of your system's membrane will depend on the quality of the water entering the system and the frequency with which you use it. Frequent use prevents the dissolved salts from building up on the membrane as scale. The more water the system is required to produce, the longer the membrane will last. You may wish to find a variety of uses for your system in order to prolong the life of the membrane. The life of the membrane will also depend upon the regularity with which you replace the pre-filter cartridge in the system.

Replacement Parts

A	ROR Replacement Cartridge Kit	155923	H	Housing o-ring (OR-233)	151231	O	1/4- Inch Elbow	143370
B	ROM-230T Membrane (RO-3000)	155854	I	Left and Right Housing	153126	P	Drain Clamp Assembly	144616
C	ROM-230TN Membrane (RO-3500)	155855	J	Middle (Membrane) Housing	153158	Q	Saddle Valve	144730
D	Nitrate/Nitrite Test Kit (RO-3500)	144925	K	Drinking Water Faucet	144839	R	Membrane Locking Device	144847
E	TDS Test Kit (RO-3000)	150530	L	Housing Wrench	150424	S	Tank Valve	144829
F	Manifold Cover	144747	M	Auto Shut-Off Assembly	144653	T	Storage Tank with Stand	144165
G	Monitor (RO-3500)	157845	N	3/8-Inch Elbow	144764			

For replacement parts contact your nearest Pentek Filtration dealer or call 800-645-0267

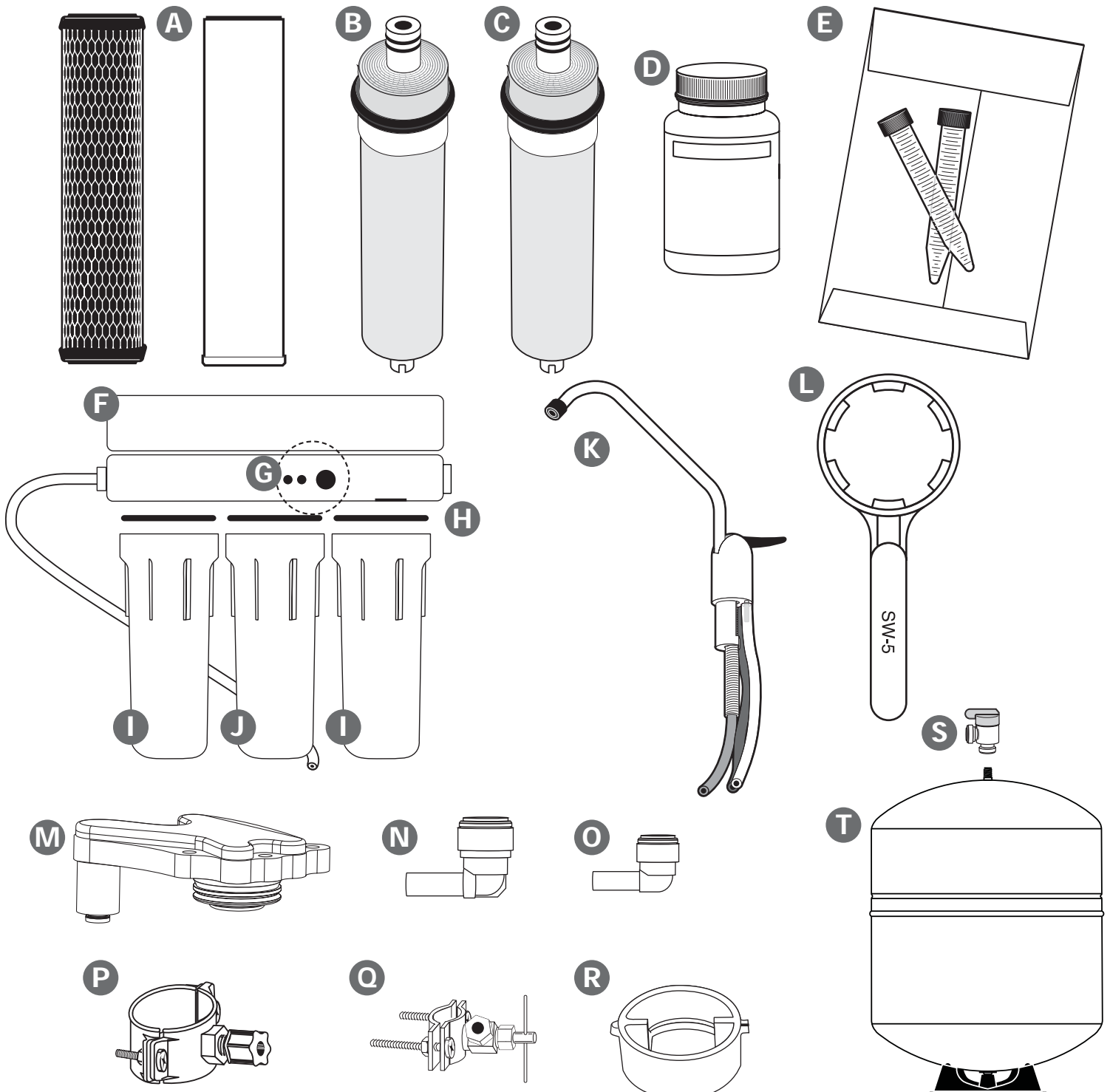

Installation

- Read all installation and operating instructions before installing and using your RO system.
- Numbered diagrams correspond with numbered steps.

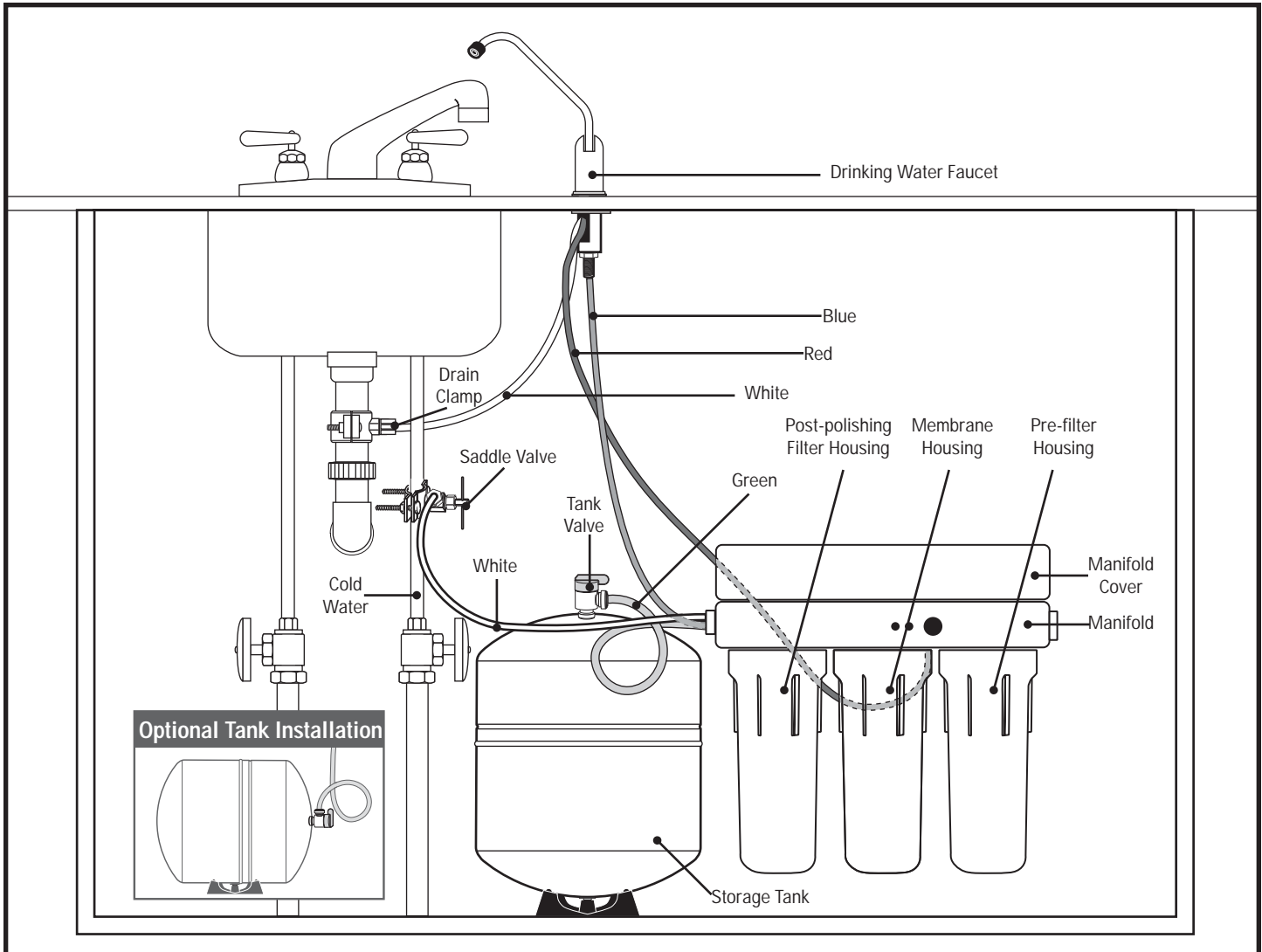

1. Installing the Saddle Valve

WARNING: Use of a hand drill is recommended. To protect yourself from serious injury or fatal shock when using an electric drill, be sure the drill and the outlet it is plugged into are properly grounded. When using a drill, follow the manufacturer's guidelines and procedures.

NOTE: Saddle valve must be installed on a 2-inch long, straight-walled section of 3/8-inch to 7/8-inch steel, brass, copper, or PVC pipe. Call Technical Support if installing on braided or flexible tubing.

- Turn off cold water supply.
- Turn on the cold water faucet before starting installation. Place a tray or towels under the cold water line to catch excess water.
- Drill a 1/8-inch hole in cold water line. Remove any burrs with sandpaper or file.
- Turn handle on saddle valve clockwise to expose lance no more than 3/16-inch beyond black rubber gasket.
- Place saddle valve body over hole in cold water line so lance fits into hole.
- Attach back plate of clamp and tighten bolts evenly and firmly so brackets are parallel.
- Turn handle on saddle valve clockwise to closed position. Leave closed until installation is complete.

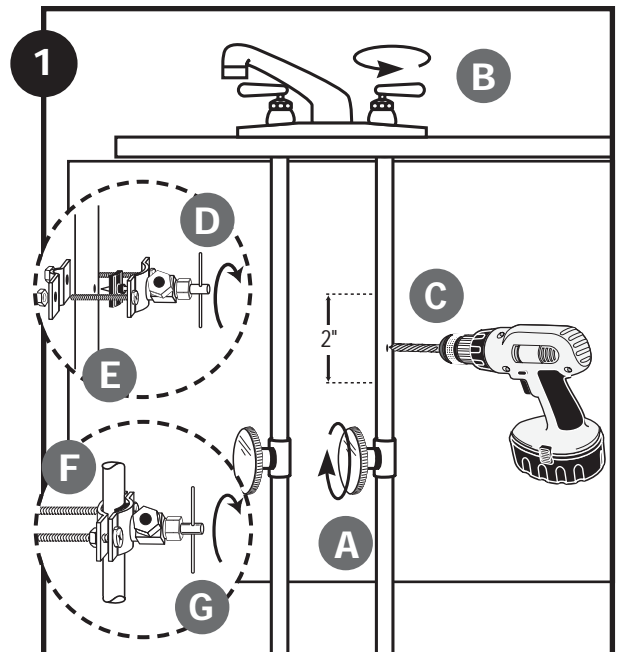

Installation Continued

2. Selecting the Faucet Location

The drinking water faucet should be positioned with function, convenience and appearance in mind. An adequate flat area is required to allow faucet base to rest securely. The faucet fits through a 1¼-inch hole. Most sinks have pre-drilled 1½-inch or 1¾-inch diameter holes designed for spray hoses. The drinking water faucet may be installed using one of these holes, despite their larger size. If these pre-drilled holes cannot be used or are in an inconvenient location, it will be necessary to drill a 1¼-inch hole in the sink or through countertop next to the sink for the faucet.

3. Drilling the Faucet Hole

CAUTION: This procedure may generate dusts which can cause severe irritation if inhaled or come in contact with the eyes. The use of safety glasses and respirator for this procedure is recommended.

CAUTION: DO NOT ATTEMPT TO DRILL THROUGH AN ALL-PORCELAIN OR PORCELAIN-COATED SINK. For applications on these types of sinks we recommend using the sprayer hole or mounting the faucet through the countertop.

CAUTION: When drilling through a countertop make sure the area below the drilled area is free of wiring and piping. Make certain that you have ample room to make the proper connections to the bottom of the faucet.

CAUTION: Do not drill through a countertop that is more than 1-inch thick.

CAUTION: Do not attempt to drill through a tiled, marble, granite or similar countertop. Consult a plumber or the countertop manufacturer for advice or assistance.

The following instructions apply to stainless steel sinks only.

- (A) Line bottom of sink with newspaper to prevent shavings, parts or tools from falling down drain.
- (B) Place masking tape over the area to be drilled to prevent scratches if drill bit slips.
- (C) Mark point with center punch. Use a 1/4-inch drill bit to drill a pilot hole through sink.
- (D) Use a 1½-inch hole saw to enlarge hole. Smooth rough edges with a file.

4. Mounting the Faucet

- (A) Loosen brass stem-nut on faucet, remove metal "C" disc.
 - (B) Holding the faucet, feed the three tubes through the hole in the sink. Position the faucet handle at a desired location.
 - (C) Center the faucet and slip "C" disc between the white spacer and the bottom of the counter or sink. Tighten the stem nut with a wrench until it is tight.
 - (D) Making sure the faucet handle is in the down position, use a needle-nose pliers to pull the short plastic tube out of the top of the faucet base.
- NOTE:** If handle should come off faucet base, make sure the T-Bar is parallel to the front of the faucet base before inserting handle. If T-Bar is not in the correct position, the faucet will not work properly.
- (E) Lubricate the o-rings on the bottom of the faucet spout with supplied silicone lubricant. Use lubricant sparingly.
 - (F) Insert goose-neck spout into faucet base firmly.

5. Installing the Drain Clamp

NOTE: If you have a single-basin sink with a disposal unit, call Technical Support for options.

NOTE: Before installing the drain clamp, check the drainpipes under the sink for corrosion. Corroded pipes should be replaced before continuing with installation.

- (A) Attach the drain clamp to a vertical section of the drainpipe, about 6-inches above the trap. Make sure the opening on the drain clamp is facing towards the drinking water faucet.
- (B) Using the fitting hole of the drain clamp as a guide, drill 1/4-inch hole through one side of the drainpipe.
- (C) Remove the drain clamp from the drainpipe and enlarge the hole with a 3/8-inch drill bit. Use a file to remove rough edges from the drilled hole.
- (D) Make sure the black rubber gasket is adhered to the inside of the drain clamp and place the drain clamp assembly over the drilled hole. Look through the hole and position the clamp so that the center of the clamp hole is slightly higher (about 1/16-inch) than the center of the drilled hole. (See figure 5 D on page 6). Tighten the clamp securely.
- (E) Screw the plastic compression nut onto the drain clamp until hand-tight. (See figure 5 E on page 6).

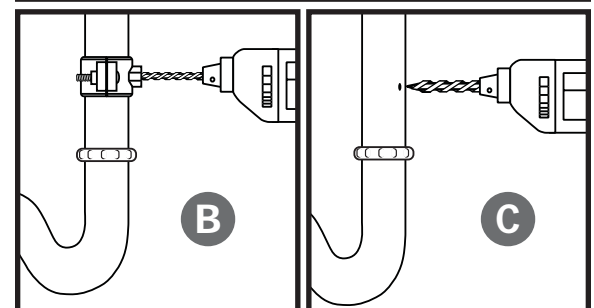
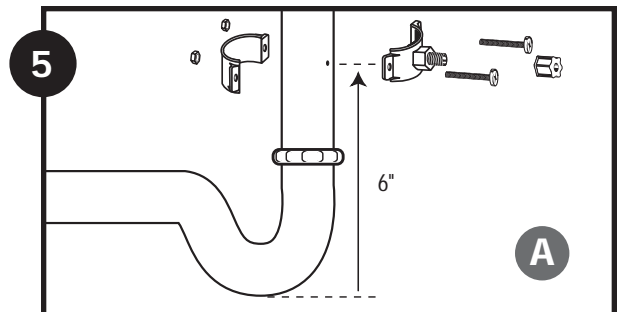
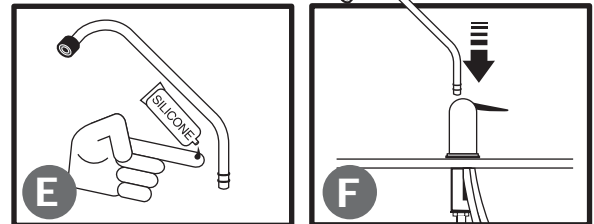
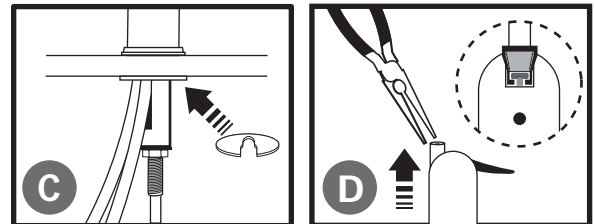
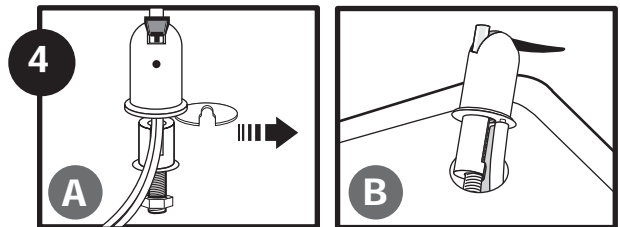
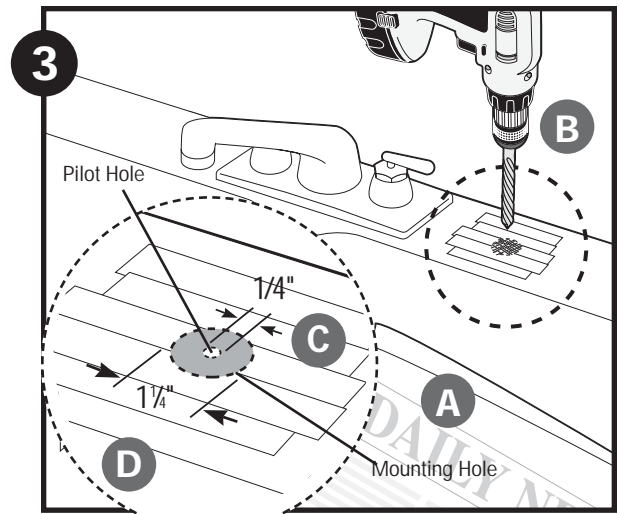

Installation Continued

6. Connecting the Faucet to the Drain

NOTE: THIS IS A GRAVITY DRAIN LINE. ANY LOOPS, KINKS OR SHARP BENDS MUST BE ELIMINATED BEFORE PROCEEDING. FAILURE TO CREATE A STRAIGHT LINE TO THE DRAIN MAY RESULT IN REJECT WATER LEAKING THROUGH THE AIR GAP IN THE FAUCET ONTO THE COUNTERTOP AND BELOW THE FAUCET.

- (A) Align the white 3/8-inch tubing from the faucet with the compression nut on the drain clamp. Create as straight a path as possible with the tubing. Cut the tubing squarely below the nut and remove the internal and external burrs.
- (B) Loosen the compression nut two complete turns. Insert the tubing into the nut until it stops. Tighten with fingers, then tighten 1 to 2 turns with a wrench.

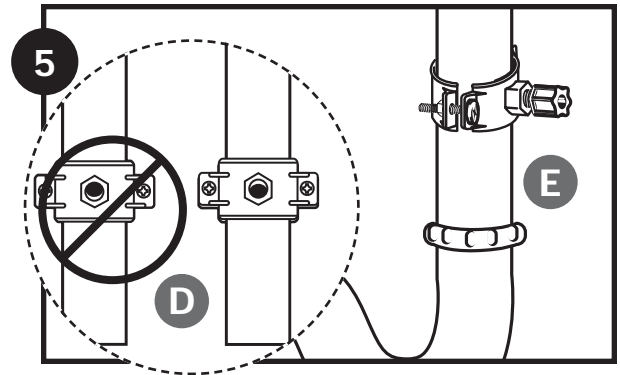

7. Installation of Mounting Screws

- (A) If system is being installed under the kitchen sink, locate it on back or right wall. Make sure to allow ample space for installation. To change the filter cartridges, a minimum of 1½ inches of clearance is required underneath the filter housings. A minimum of 2-inches of clearance from the left side of the unit is also required or six inches from the left bracket mounting screw hole. Install mounting screws at least 13/16 inches from cabinet floor and 5/8 inches apart. Leave 5/16-inch space between the head of the screw and the wall to slip bracket onto screws.

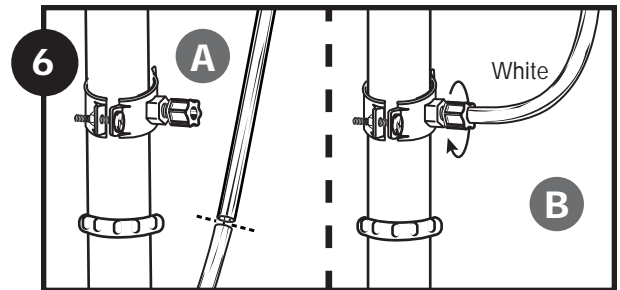

8. Connecting the Faucet to the System

- (A) Locate the red tubing (reject water line) from the drinking water faucet. Place a mark on the red tubing 5/8-inch from the end. Moisten the end of the tubing with water and insert tubing into the red quick-connect fitting found behind the membrane (middle) housing. Insert tubing until the mark is flush with the quick connect opening.
- (B) If desired, use the 1/4-inch elbow included with the installation kit. This elbow can be pressed in for installations in situations where room is not available to bend the tubing. This elbow fitting can also be swiveled. Locate the 1/4-inch fitting with the blue quick-connect collar on the left hand side of the RO system. Align the blue tubing from the faucet with the quick-connect fitting on the RO system. Place a mark on the blue tubing 5/8-inch from the end. Moisten the end of the tubing with water and insert until the mark is flush with the quick-connect opening. If tubing is not firmly connected, leaking will occur. It is important for the tubing to be inserted all the way until the mark is flush with the outer edge of the quick-connect insert.

NOTE: Tubing may be quickly and easily removed from the fitting if necessary by pressing in the collar around the fitting while pulling the tubing with your other hand.

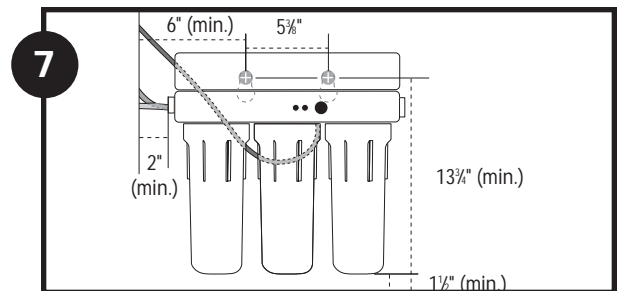

9. Connecting the Storage Tank to the System

CAUTION: When tank is full, it weighs approximately 40 lbs. Provide ample support under the tank.

- (A) Remove the black protective cap to expose the 1/4-inch threaded opening at the top of the tank.
- (B) Thread the tank valve onto the top of the tank opening by turning it clockwise until snug.
- (C) Locate the green tubing. Place a mark on the green tubing 3/4-inch from each end. Moisten one end of the green tubing with water and insert with a twisting motion into the free port of the tank valve until the 3/4-inch mark is flush with the quick connect fitting.
- (D) Install free-end of green tubing to green quick-connect fitting or elbow as directed in step 9C.

NOTE: Do not cut green tube. This line should be left at the pre-cut length for future service.

- (E) Place entire system over mounting screws on wall and slide down.

CAUTION: Make certain system is firmly attached to wall to prevent it from falling and possibly becoming damaged.

NOTE: Use caution not to bend or pinch the tubing behind the system while attaching to mounting screws.

NOTE: The pressurized storage tank has a capacity of 1.9 to 3.2 gallons. The tank's air pressure is factory set at 5 to 7 psi when tank is empty.

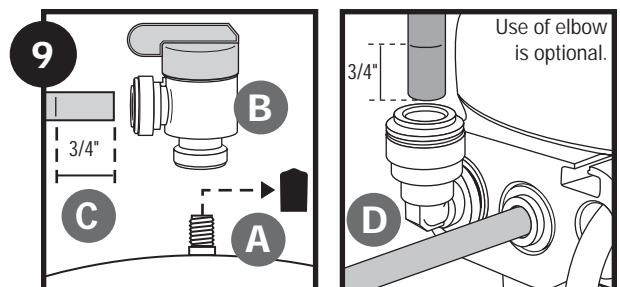
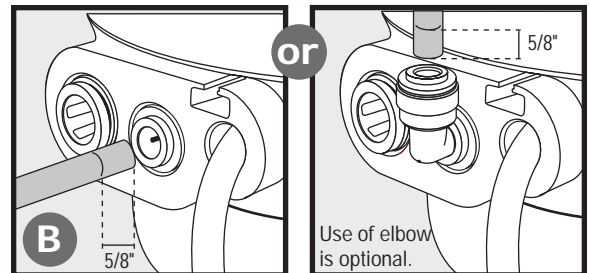
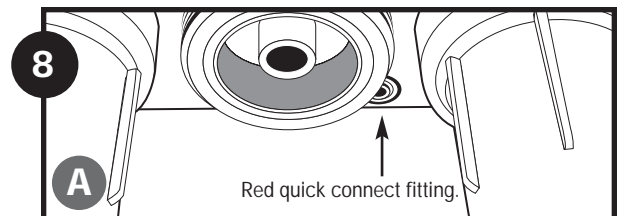

Installation Continued

10. Connecting the Saddle Valve

- (A) Locate pre-installed white plastic tubing found on the left hand side of the RO system. Slide the brass compression nut onto the tubing, followed by the white plastic ferrule. The long tapered end of the ferrule should face towards the end of the tubing and the tubing should extend through the ferrule about 1/4-inch. Place white insert into end of tubing.
- (B) Insert white plastic tubing into saddle valve and hand-tighten compression nut. Using a wrench, tighten nut 1 to 1 1/2 turns.

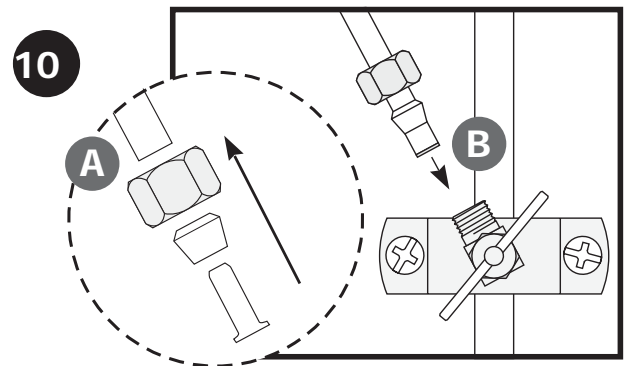

11. Installing the Membrane

- (A) Using the housing wrench, unscrew the middle (membrane) housing.
- NOTE:** Do not unwrap the tape around the membrane; it is part of the membrane. Do not squeeze the membrane.
- (B) Turn locking device clockwise to remove. Grasp the membrane by the central tube (the end with the two o-rings). Before insertion, lightly lubricate the brine seal with the silicone lubricant (included with membrane).
- (C) Gently slide the membrane into the housing. Pressing on the central tube of the membrane from the top only, push the membrane fully into the housing until the central tube is flush with the top of the housing. Be sure to push the membrane straight down into the housing. If the membrane is not centered in the housing, the locking device will not fit properly. After the membrane is seated, lightly lubricate the membrane o-rings with a small amount of silicone lubricant.
- (D) Insert, then turn the locking device counter-clockwise. Screw the housing back onto the RO system until it is hand-tight. **DO NOT OVER TIGHTEN.**
- CAUTION:** The housing o-ring provides the watertight seal between the cap and the housing. It is important that the o-ring be properly seated in the groove below the threads of the housing or a water leak could occur.

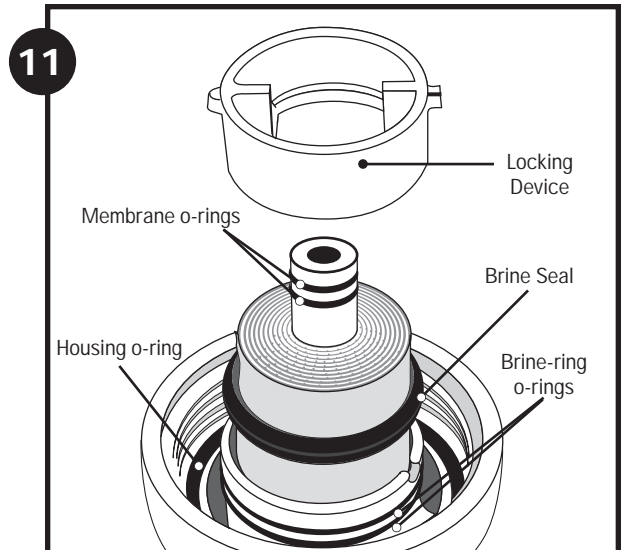

12. Faucet Operation

- (A) For controlled water flow, push the handle down.
- (B) For constant water flow, lift the faucet handle to lock it in the open position.

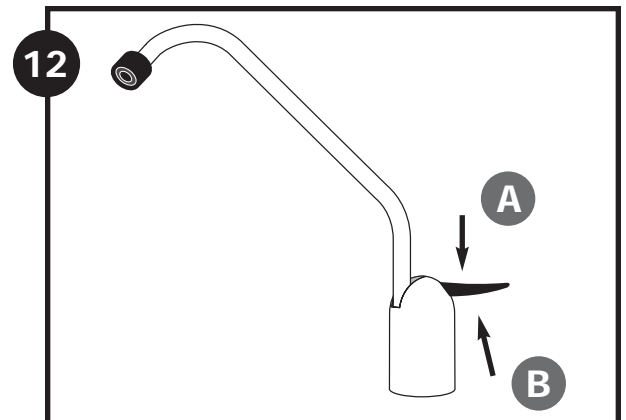

13. Battery Installation (RO-3500 only)

- (A) Remove manifold cover.
- (B) Plug battery into leads.
- (C) Place battery in holder at the front of unit and replace cover.

14. System Startup

- NOTE:** The reverse osmosis membrane is treated with a food grade sanitizing agent that may cause an undesirable taste. Although it is not harmful, it should be flushed from the system.
- NOTE:** The post-polishing filter may contain fine black carbon particles. These fines are harmless, but may make the water appear gray in color. The carbon fines are flushed from the system with the first tank full of water.
- NOTE:** The RO system does not produce a high volume of water on demand as an ordinary filter does. Water is produced at a slow, drop-by-drop rate. The system requires about 6-12 hours to fill the storage tank. As water is taken from the tank, the system automatically starts the cycle of replacing the water and then stops water production when the tank is full.
- CAUTION:** Visually check the entire system for leaks. Remove the manifold cover and check the top of the manifold for leaks. If a leak is present, see **Troubleshooting** on page 12.
- (A) Turn off valve at top of storage tank.
- (B) Turn on the cold water supply.
- (C) Completely open saddle valve until it comes to a stop.
- (D) Lift the faucet handle to lock it in the open position and let it drip for 30-minutes.
- NOTE:** On the Model RO-3500, if the test button is pushed during the first 30-minutes of flushing, you may get an amber rather than a green light indication. This is due to the disinfectant agent being flushed from the membrane and is not a problem.
- (E) Close the saddle valve and wait for the faucet to stop dripping. Place a tray under the system and remove the left (post-polishing) filter housing. Dump the water from the housing into the sink and insert a white post-polishing filter with the black gasket end facing up. Check the housing o-ring to make sure it is properly seated and screw the housing back onto the manifold. **HAND TIGHTEN ONLY.**

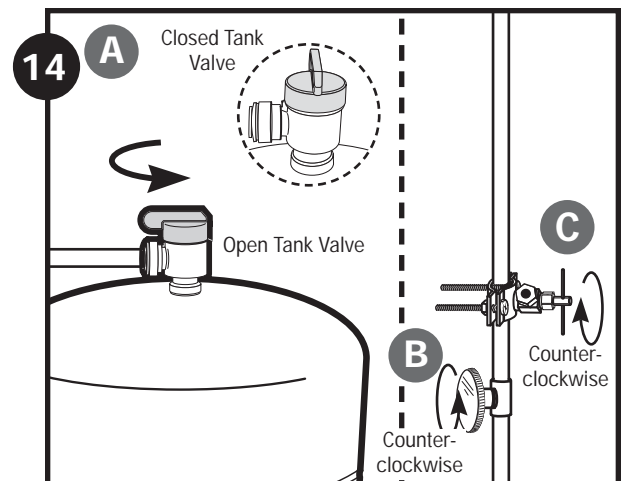

Installation Continued

14. System Startup (Continued)

- (F) Completely open the saddle valve until it comes to a stop. Allow water to drip from the faucet for 3 more hours. Then close the faucet and open the valve on the storage tank. The tank valve is open when the handle lines up with the tubing connection.
- (G) Allow 6- to 12-hours for the tank to fill. Again, periodically check the installation for leaks. After the storage tank is filled, open the faucet to flush the post-polishing filter. Allow 4- to 5-minutes for all of the water to drain from the tank.
- (H) Close faucet and allow tank to fill.

NOTE: Initially, the water may appear cloudy. This is a result of air trapped in the post-polishing filter. It is not harmful and will disappear in a matter of minutes. It may take up to a week after installing a new post-polishing filter for the trapped air to dissipate.

The system is ready for operation.

You can now enjoy quality water from your Reverse Osmosis system.

Optional Installation

Connecting your Reverse Osmosis system to Refrigerator/Icemaker / Water Dispenser

CAUTION: If you are connecting this unit to your refrigerator/icemaker with initial RO installation, wait to turn on the icemaker until the post-polishing filter has been flushed according to Step 14-G on page 8.

CAUTION: Use plastic tubing and fittings. Do not use copper tubing or brass fittings.

NOTE: For optimum performance, it is recommended that the distance between the RO system and the refrigerator icemaker/water dispenser be no greater than 10-feet (3 m). At distances greater than 10-feet, the water pressure from the system may not be adequate to deliver water to the refrigerator.

MATERIALS REQUIRED:

(Available at your local hardware store)

- 1/4-inch x 1/4-inch x 1/4-inch (0.635 cm x 0.635 cm x 0.635 cm) compression or quick-connect tee.
 - 1/4-inch (0.635 cm) Polyethylene tubing (maximum length of 10-feet (3m) recommended)
 - Shut-off valve
1. Turn off refrigerator water supply and icemaker. (Consult manufacturer's guidelines)
 2. Close tank valve (on top of storage tank).
 3. Turn off water to RO system at the saddle valve.
 4. Open drinking water faucet to relieve pressure.
 5. Locate Blue tubing leading to your drinking water faucet. Cut and insert the 1/4-inch x 1/4-inch x 1/4-inch compression or quick-connect tee into the blue tubing. (Consult manufacturer's guidelines before installing the tee connection).
- NOTE:** When cutting this blue tubing, you may experience some water leakage.
6. Using a length of 1/2-inch polyethylene tubing, connect the icemaker/dispenser line with the free port on the compression tee.
 7. The shut-off valve should be installed as close to this port of the tee as possible. Shut-off valve should be installed in the OFF position. (Consult manufacturer's guidelines before installing the shut-off valve)
 8. Completely open saddle valve (until it comes to a stop).
 9. Open tank valve.
 10. Turn off the drinking water faucet.
 11. Open shut-off valve at the tee connection.
 12. Turn on icemaker. (Consult manufacturer's instructions).
 13. Check for leaks and tighten connections if necessary.

Testing your Pentek Reverse Osmosis System

Model RO-3000 Reverse Osmosis System

1. Total Dissolved Solids (TDS) Test

NOTE: Under NSF/ANSI Standard 58, it is highly recommended that you (the consumer) have your water tested at least every 6 months to verify that your system is performing satisfactorily.

Sampling Instructions:

Sampling instructions are included with the Total Dissolved Solids (TDS) Test Kit. If the TDS Test Kit is missing from your unit, please call 1-800-861-8758 for a replacement.

Model RO-3500 Monitored Reverse Osmosis System

1. Light Indicator Readings on Model RO-3500

The RO-3500 is equipped with a monitor that checks the Total Dissolved Solids (TDS) that the system is reducing. This allows the user to see the quality of the water that the system is producing. Test the unit monthly. When the blue test button is pushed, the light system will read one of the following colors:

Green Light: Good Water

Amber Light: If this is a new installation, call Technical Support. Otherwise, draw 1-gallon of water from the unit. After 10-minutes, push button to test. If the light is still amber, change the pre-filter and empty the tank. If after 1-hour the light is still amber, you may need to replace the membrane. Determine when you last changed the membrane and call Technical Support at 1-800-861-8758.

No Light: The battery needs to be changed.

2. Nitrate Test Kit

A Nitrate Test Kit is included with this unit and is designed to indicate nitrate levels in the drinking water. Test the water monthly. The current EPA Maximum Contaminant Level (MCL) for Nitrate as Nitrogen (N) is 10 mg/L or 10 ppm. The current EPA maximum contaminant level (MCL) for Nitrite as Nitrogen (N) is 1mg/L or 1ppm. Results showing any nitrate breakthrough should be followed up with a laboratory analysis of the water.

WARNING: Consult with your doctor to see if you or your family should drink water with the nitrate/nitrite levels found in your water.

Testing Instructions:

Testing instructions are included with the Nitrate Test Kit. If the Nitrate Test Kit is missing please call 1-800-861-8758 for replacement.

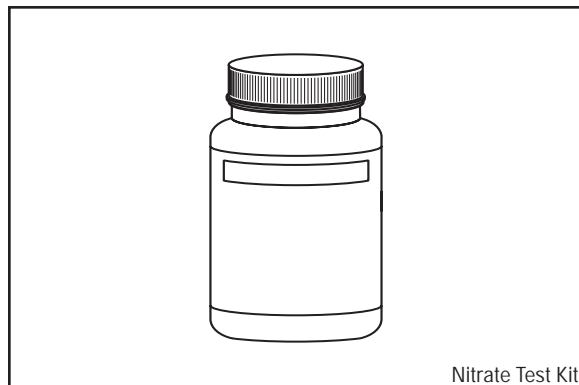
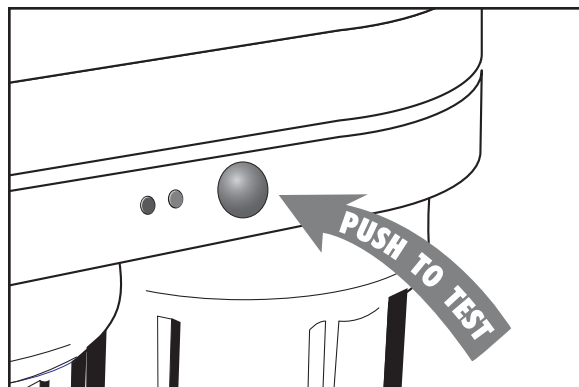
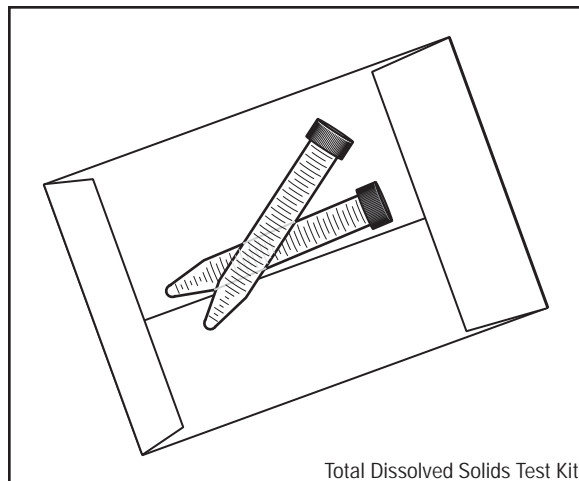

Maintenance

Use only the replacement elements and parts referred to in this manual. Failing to do so will void your warranty.

Replacing the Pre-Filter and Post-polishing Filter Cartridges

Replacement Filter Cartridges

- The USL-NCR Pre-Filter Cartridge (grey/black) should be replaced every 4 months, or earlier if your water is highly turbid and when changing the membrane.
- The USL-CC Post-polishing Filter Cartridge (white) should be replaced at least every 12 months and when changing the membrane.

Materials Needed:

- New Cartridges (USL-NCR, USL-CC)
- FDA Grade Silicone Grease
- Clean Washcloth
- Non-abrasive brush or sponge
- Clean Rubber Gloves (optional)
- Dishwashing Soap

Replacing the Filter Cartridges

1. Close saddle valve and place a tray under the system to catch any water that spills during removal of the filter housings. If an icemaker is attached to the unit, turn it off and also the shut-off valve found at the 1/4-inch tee connection.
2. Lift the faucet handle to lock it in the open position.
3. After water flow from the faucet stops, unscrew the filter housing from the left and/or right side of the manifold, do not remove the membrane (center) housing. Discard used cartridges.
4. Remove the housing o-ring from grooves in the housing. Wipe the grooves and o-ring clean; set o-ring aside.
NOTE: Use clean rubber gloves or wash hands thoroughly for this procedure to avoid contaminating the cleaning solution or any of the components of the system. It is recommended that clean rubber gloves be worn when cleaning and/or sanitizing the system and its components or handling new filter cartridges.
5. Wash the housing and o-ring in the sink with dishsoap and a clean, non-abrasive washcloth or brush. Clean the filter housing, the inside of the manifold and the o-ring and rinse them well with clean, potable water. Inspect the o-ring for damage (i.e. nicks, scratches) and replace damaged o-rings. (See page 3 for reorder information and part numbers).
NOTE: Do not get any of the electronic circuits or wiring wet when cleaning the unit.
6. Lightly lubricate the o-ring with a coating of clean silicone grease. With two fingers, press o-ring securely into groove below the threads of the housing.

CAUTION: The housing o-ring provides the water-tight seal between the cap and the bottom of the housing. It is important that the o-ring be properly seated in the groove below the threads of the housing or a water leak could occur.

7. Insert the new cartridge into the housing. Make sure the cartridge slips over the standpipe in the bottom of the housing

NOTE: Be sure to install cartridges in proper housings (see the diagram on page 4).

8. Screw the housing back onto the manifold. **HAND-TIGHTEN ONLY.**
9. Slowly open the saddle valve until it comes to a stop. Check for leaks.
10. Let water drip from drinking water faucet for 3-hours. Continue to periodically check for leaks.
11. Close faucet and wait 6-12 hours to allow the tank to fill. Open the drinking water faucet and drain one full tank to flush the carbon fines out of the system.
12. If the unit is attached to an icemaker, wait one hour before turning on the ice maker.

Replacing the Reverse Osmosis Membrane

Replacement Filter Cartridges

Replacement Filter Cartridges

- The USL-NCR Pre-Filter Cartridge (grey/black) should be replaced every 4 months, or earlier if your water is highly turbid and when changing the membrane.
- The USL-CC Post-polishing Filter Cartridge (white) should be replaced at least every 12 months and when changing the membrane.
- The **ROM-230T Membrane (RO-3000)** and the **ROM-230TN Membrane (RO-3500)** should be replaced every 12-24 months.

Materials Needed:

- New Cartridges (USL-NCR, USL-CC)
- New membrane
- Clean Rubber Gloves
- Clean Washcloth
- Dishwashing Soap
- Chlorine Bleach
- FDA-Grade Silicone Grease
- Needle-nose pliers
- Safety Glasses
- Large bucket
- 9-Volt battery
- Non-abrasive brush or sponge

NOTE: When handling the membrane, do not squeeze it, as this will damage the membrane's effectiveness.

NOTE: It is recommended that you sanitize the system each time you change the membrane. It is not necessary to sanitize the system when changing only the pre-filter or post-polishing filter cartridges.

NOTE: When installing a new membrane, it is recommended that you replace the pre-filter and post-polishing filter cartridges as well.

Replacing the Filter Cartridges and Membrane

1. Turn off water supply at the saddle valve. Place a tray under the system to catch any water that spills during the removal of the filter housings. If an icemaker is attached to the unit, turn it off along with the shut-off valve found at the 1/4-inch tee connection.
2. Open the drinking water faucet to drain the tank. When the tank is drained, close the faucet.
3. Unscrew the middle (membrane) housing.
4. Remove the locking device by turning it clockwise. Grasp the membrane tube with a needle-nose pliers and pull. Discard the old membrane.
5. Unscrew the pre- and post-filter housings from the manifold and discard used cartridges.
6. Remove the housing o-ring from the grooves below the housing threads. Wipe the o-rings clean and also the grooves in the filter housing. Set o-rings aside.

NOTE: Use clean rubber gloves or wash hands thoroughly for this procedure to avoid contaminating the cleaning solution or any of the components of the system. It is recommended that clean rubber gloves be worn when cleaning and/or sanitizing the system and its components or handling new filter cartridges.

7. Wash the housings in the sink with dishsoap and a clean, non-abrasive washcloth or brush. Clean the filter housings and the inside of the manifold and rinse them well with clean, potable water. Do not get any of the electronic circuits or wiring wet when cleaning the unit.

CAUTION: WEAR SAFETY GLASSES WHILE PERFORMING THIS PROCEDURE TO AVOID EYE CONTACT AND INJURY.

CAUTION: Read "WARNING" information on the bleach container before using its contents.

CAUTION: Handle sanitizing solution carefully to avoid contacting and injuring unprotected areas of the body.

Maintenance continued

8. Make up a sanitizing solution of 1/3 teaspoon (1.5 ml) of household bleach and 1 gallon (3.8L) of clean, potable water in a bucket. Mix solution well.

NOTE: Excessive concentrations of bleach may damage plastic and rubber components. Rinse all parts that contact bleach thoroughly with clean, potable water.

9. Lightly lubricate each housing o-ring with a coating of clean silicone grease. With two fingers, press each o-ring securely into groove below the threads of the housing.

CAUTION: The housing o-ring provides the water-tight seal between the cap and the bottom of the housing. It is important that the o-ring be properly seated in the groove below the threads of the housing or a water leak could occur.

10. Add one cup or 8 oz. (236 ml) of sanitizing solution to each filter housing and install them onto the manifold. (DO NOT INSTALL FILTERS OR MEMBRANE AT THIS TIME)

NOTE: TIGHTEN FILTER HOUSINGS BY HAND ONLY. DO NOT USE WRENCH.

11. Slowly open source water at the saddle valve until completely open.
12. Open the drinking water faucet. Close the faucet as soon as water begins to flow from the spout.

13. Wait 5 minutes, then close the source water at the saddle valve.

14. Wait 25 minutes, then open the drinking water faucet and let the water flow to drain.

NOTE: Do not attempt to remove the filter housings until the water flow stops.

15. Remove the filter housings and dispose of the water. Rinse the housings thoroughly with clean, potable water.

16. Place the empty post-polishing filter housing on the left side of the unit. HAND TIGHTEN ONLY.

NOTE: DO NOT put the USL-CC (post-polishing) filter into the housing at this time. It will be put into the housing after the membrane has been flushed.

17. Insert the USL-NCR (pre-filter) cartridge into the right housing and attach to the right side of the unit. HAND TIGHTEN ONLY.

NOTE: Use the silicone lubricant supplied with the membrane for Steps 18,19 & 21.

18. Lightly lubricate the inside of the membrane (middle) threaded cap. (See diagram 1)

19. Lightly lubricate both sides of the brine seal. (See diagram 2)

20. Gently slide the membrane into the housing. Pressing on the central tube of the membrane from the top only, push the membrane fully into the housing until the central tube is flush with the top of the housing. Be sure to push the membrane straight down into the housing. If the membrane is not centered in the housing, the locking device will not fit properly.

21. After the membrane is seated, lightly lubricate the two small o-rings at the end of the membrane. Also, lightly lubricate both brine ring o-rings. (See diagram 1)

CAUTION: The rubber o-rings provide the water-tight seal between the cap and the housing. It is important that the o-ring be properly seated in the groove below the threads of the housing or a water leak could occur.

22. Insert, then turn the locking device counter-clockwise. Screw the housing back onto the RO system until it is hand-tight. DO NOT OVER TIGHTEN.

23. To complete the flushing of the membrane and USL-CC (post-polishing filter) and assembly of the unit go to Step 14 System Startup on page 7.

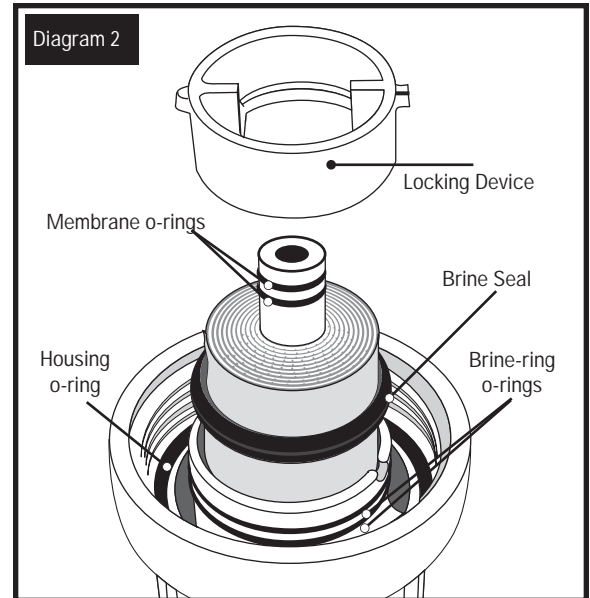
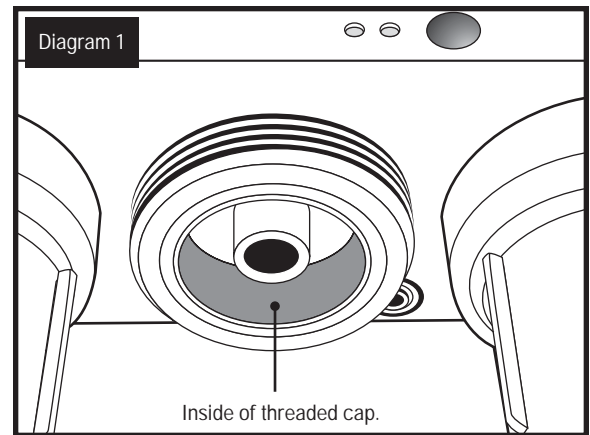

Troubleshooting Guide

If you are experiencing a problem not listed in this manual, shut off the water supply at the saddle valve, and close the tank valve. Call Technical Support at 1-800-861-8758.

Leaks between the filter housing and manifold:

1. Turn off cold water supply to system at saddle valve. Close tank valve. Open drinking water faucet to relieve water pressure.
2. Using the housing wrench, remove the housing with the leak.
3. Remove and clean housing o-ring and lubricate with clean silicone grease. Clean o-ring groove below threads of housing to remove any dirt or particles that may be preventing the o-ring from sealing completely. With two fingers, insert o-ring in groove and press into place.
4. Tighten housing back onto manifold. **HAND TIGHTEN ONLY.**
5. Turn on water supply at saddle valve. Open tank valve. Close drinking water faucet after water begins to flow. If leaks persist, call Technical Support.

Leak between tank valve and storage tank:

1. Turn off water supply to system at the saddle valve. Open faucet to drain storage tank. Let faucet run for 3-5 minutes until it drips.
2. Remove green tubing from tank valve by pressing the collar around the fitting while pulling the tubing with your other hand.
3. Unscrew the tank valve from the storage tank.
4. Place two wraps of Teflon® tape on the threads of the storage tank.
5. Thread the tank valve onto the top of the tank opening by turning it clockwise until snug.
6. Cut off 1-inch of tubing. Tubing should be cut squarely. Internal and external burs should be removed. Place a mark on tubing 3/4-inch from end of tubing.
7. Insert tubing until the mark is flush with the quick connect fitting.
8. Turn water supply on at the saddle valve and close drinking water faucet.
9. Allow system to pressurize for several hours and check for leaks.
10. Check for leaks after tank is fully pressurized (6-12 hours). If leak persists, call Technical Support.

Leaks at quick-connect fittings:

1. Close tank valve, close saddle valve and open drinking water faucet.
2. Press collar around the quick connect fitting while pulling the tubing with your other hand.
3. Cut off 1 inch of tubing. Tubing should be cut squarely. Internal and external burs should be removed. Place a mark on tubing 5/8-inch from end on 1/4-inch tubing or 3/4-inch from end on 3/8-inch tubing.
4. Insert tubing until the mark is flush with the quick connect fitting.
5. Open the saddle valve until it comes to a stop. Open the tank valve and close drinking water faucet. If leaks persist, call Technical Support.

Leaks from faucet

1. Check to make sure white tubing leading from the drinking water faucet to the drain is as straight as possible (it is usually necessary to cut this line during installation). Any kinks or sags in this drain line will impede the flow of water to the drain.
2. Check to make sure there is no foreign matter clogging the drain line or at the drain clamp hole. If leaks persist, call Technical Support.
3. Check to make sure the drain clamp and the drain hole are properly aligned. (Refer to diagram 5 D on page 6).

No flow or slow flow from the brine (reject) line

(less than 6 fl. oz. or 180 milliliters per minute).

NOTE: Before checking brine (or reject) flow, make sure the unit is producing water by turning the valve on the storage tank off and opening the drinking water faucet. Water should drip from faucet.

1. Replace pre-filter according to "Replacing the Pre-filter and Post-polishing filter Cartridges" instructions on page 10 and recheck the Brine (or reject) flow rate.
2. If the pre-filter is not at fault, the brine (or reject) flow controller could be clogged. Call Technical Support.

High TDS in Product Water (Amber Light on RO-3500):

If high TDS (Total Dissolved Solids) is detected in the product water, the amber light indicator on the RO-3500 will light when the blue button is pressed. The pre-filter may need to be changed, the RO membrane may need to be installed or replaced, or the reject flow control tubing may be clogged. If this is a new installation, call Technical Support. Otherwise, draw 1 gallon of water from the unit. After 10 minutes, push the button to test. If the light is still amber, change the pre-filter and empty the tank. If after 1 hour the light is still amber you may need to replace the membrane. Determine when you last changed the membrane and call Technical Support at 1-800-861-8758

Limited Flow at Drinking Water Faucet:

1. Turn off water supply to system at saddle valve.
2. Lift drinking water faucet handle to lock it in the open position.
3. Unscrew the blue cap at the base of the storage tank to expose air valve. Use a small air compressor or bicycle pump to add air to the storage tank. This will force the water out of the storage tank through the faucet. Continue to add air until no more water comes out of the faucet.
4. Turn off the drinking water faucet.
5. Using an air pressure gauge, adjust the pressure in the storage tank to approximately 7 psi.
6. Replace the blue cap.
7. Open the saddle valve until it comes to a stop. Let the system run 6-12 hours to fill the tank. A full tank weighs approximately 40-pounds. If performance has not improved, call Technical Support.

Gradual Return of Taste and Odor:

After a long period of time a gradual return of noticeable taste and odors may indicate that the system needs cleaning and servicing. Replace all cartridges. See Replacing the Reverse Osmosis Membrane on page 10.

Sudden Return of Taste and Odor:

If shortly after complete servicing, noticeable taste and odors return, contact Technical Support.

Performance Data

Important Notice: Read this performance data and compare the capabilities of this system with your actual water treatment needs. It is recommended that before installing a water treatment system, you have your water supply tested to determine your actual water treatment needs.

This system has been tested according to NSF/ANSI 58 for the reduction of substances listed below. The concentration of the indicated substances in water entering the system was reduced to a concentration less than or equal to the permissible limit for water leaving the system as specified in NSF/ANSI 58.

Model RO-3000

Substance	Influent Challenge Concentration	Max Permissible Product Water Concentration	Reduction Requirements	Minimum Reduction	Average Reduction
Standard 58					
Total Dissolved Solids	750 ± 40 mg/L	187 mg/L		86.5%	90.2%
Fluoride	8.0 mg/L ± 10%	1.5 mg/L		77.5%	90.5%
Cysts	Minimum 50,000/mL		99.95%	99.96%	99.99%
Turbidity	11 mg/L ± 1 NTU	0.5 NTU		99.5%	99.7%
Lead	0.15 mg/L ± 10%	0.010 NTU		94.3%	98.7%
Selenium	0.10 mg/L ± 10%	0.05 mg/L		94.7%	97.5%
Copper	3.0 mg/L ± 10%	1.3 mg/L		98.9%	99.9%

Standard 42 USL-CC Post-Polishing Filter

Chlorine	2.0 ppm	<0.05 ppm			>88%
Production Rate: 7.6 gpd (28.8 Lpd)					

Model RO-3500

Substance	Influent Challenge Concentration	Max Permissible Product Water Concentration	Reduction Requirements	Minimum Reduction	Average Reduction
Standard 58					
Total Dissolved Solids	750 ± 40 mg/L	187 mg/L		86.5%	90.2%
Pentavalent Arsenic	0.30 mg/L ± 10%	0.025 mg/L		97.9%	98.9%
Fluoride	8.0 mg/L ± 10%	1.5 mg/L		77.5%	90.5%
Cysts	Minimum 50,000/mL		99.95%	99.96%	99.99%
Turbidity	11 mg/L ± 1 NTU	0.5 NTU		99.5%	99.7%
Lead	0.15 mg/L ± 10%	0.010 NTU		94.3%	98.7%
Nitrate plus Nitrite (both as N)					
	30.0 mg/L ± 10%	10.0 mg/L			
Nitrate (as N)	27.0 mg/L ± 10%	10.0 mg/L		82.6%	87.4%
Nitrite (as N)	3.0 mg/L ± 10%	1.0 mg/L		78.8%	80.7%
Selenium	0.10 mg/L ± 10%	0.05 mg/L		94.7%	97.5%
Copper	3.0 mg/L ± 10%	1.3 mg/L		98.9%	99.9%
Cadmium	0.03 mg/L ± 10%	0.005 mg/L		95%	97.3%
Hexavalent Chromium	0.3 mg/L ± 10%	0.1 mg/L		86.6%	86.6%
Trivalent Chromium	0.3 mg/L ± 10%	0.1 mg/L		92.8%	92.8%
Radium 226/228	25 pCi/L ± 10%	5 pCi/L			80%
Barium	10.0 mg/L ± 10%	2.0 mg/L		90.7%	90.7%

Standard 42 USL-CC Post-polishing filter

Chlorine	2.0 ppm	<0.05 ppm			>88%
Production Rate: 7.6 gpd (28.8 Lpd)					

The RO-3500 is acceptable for treatment of influent concentrations of no more than 27 mg/L nitrite in combination measured as N and is certified for nitrate / nitrite reduction only for water supplies with a pressure of 40 psig (280 kPa) or greater.

The RO-3500 shall only be used for arsenic reduction on chlorinated water supplies containing detectable residual free chlorine at the system inlet. Water systems using an in-line chlorinator should provide a one-minute chlorine contact time before the RO system.

WARNING: Do not use with water that is microbiologically unsafe or of unknown quality without adequate disinfection before or after the system. Systems certified for cyst reduction may be used on disinfected waters that may contain filterable cysts.

NOTE: Substances reduced are not necessarily in your water. Filter must be maintained according to manufacturer's instructions, including replacement of filter cartridges.

The tested efficiency rating for these systems is 11%. Efficiency rating means the percentage of the influent water to the system that is available to the user as reverse osmosis treated water under operating conditions that approximate typical daily usage. The tested recovery rating is 24%. Recovery rating means the percentage of the influent water to the membrane portion of the system that is available to the user as reverse osmosis treated water when the system is operated without a storage tank or when the storage tank is bypassed.

The RO-3500 has been tested for the treatment of water containing pentavalent arsenic [also known as As(V), As(+5), or arsenate] at concentrations of 0.30 mg/L or less. This system reduces pentavalent arsenic, but may not remove other forms of arsenic. This system is to be used on water supplies containing a detectable free chlorine residual or on water supplies that have been demonstrated to contain only pentavalent arsenic. Treatment with chloramine (combined chlorine) is not sufficient to ensure complete conversion of trivalent arsenic to pentavalent arsenic. Please see the Arsenic Facts section of the Performance Data Sheet for further information.

Test Conditions

Flow Rate	= as noted for filter system
Inlet Pressure	= 60 psi (4.1 bar)
pH	= 7.5 ± 1
Temperature	= 68°F ± 5°F (20°C ± 2.5°C)

Operating Requirements

Pressure	= 40–100 psi (2.8–6.9 bar)
Temperature	= 40–100°F (4.4–37.8°C)
Turbidity	= 1 NTU Max.

Testing was performed under standard laboratory conditions, actual performance may vary.

Model RO-3000 and RO-3500

The following performance claims for the RO-3000 and RO-3500 are not tested or certified by NSF.

Substance	Average Influent Concentration	Average (Max) Effluent Concentration	Average (Min) Reduction
Sulfate	815.8 ppm	8.4 ppm	98.9%
Magnesium	31.3 ppm	0.15 ppm	99.5%
Zinc	24.9 ppm	0.1 ppm	99.5%
Ammonia	1.92 ppm	0.27 ppm	85.9%
Tannin	2.5 ppm	0.5 ppm	80%

Testing performed at 73° F ± 5° F (22.7° C ± 2.5° c), pH of 7.5 ± 0.5 and 50 psi (3.45 bar) pressure.

Suggested Retail Price for Replacement Filter Cartridges:

ROR Cartridge Set	\$33.95
ROM-230T:	\$109.99
ROM-230TN:	\$109.99

NOTE: Price subject to change. Contact your local dealer or call: 1-800-645-0267 for current replacement cartridge pricing.

Arsenic Fact Sheet

Arsenic (abbreviated As) is found naturally in some well water. Arsenic in water has no color, taste or odor. It must be measured by a lab test. Public water utilities must have their water tested for arsenic. You can get the results from your water utility. If you have your own well, you can have the water tested. The local health department or state environmental health agency can provide a list of certified labs. The cost is typically \$15 to \$30. Information about arsenic in water can be found on the Internet at the US Environmental Protection Agency website: www.epa.gov/safewater/arsenic.html.

There are two forms of arsenic: pentavalent arsenic [also called As(V), As(+5), and arsenate] and trivalent arsenic [also called As(III), As(+3) and arsenite]. In well water, arsenic may be pentavalent, trivalent, or a combination of both. Special sampling procedures are needed for a lab to determine what type and how much of each type of arsenic is in the water. Check with the labs in your area to see if they can provide this type of service.

Reverse osmosis (RO) water treatment systems do not remove trivalent arsenic from water very well. RO systems are very effective at removing pentavalent arsenic. A free chlorine residual will rapidly convert trivalent arsenic to

pentavalent arsenic. Other water treatment chemicals such as ozone and potassium permanganate will also change trivalent arsenic to pentavalent arsenic. A combined chlorine residual (also called chloramine) may not convert all the trivalent arsenic. If you get your water from a public water utility, contact the utility to find out if free chlorine or combined chlorine is used in the water system.

The RO-3500 system is designed to remove pentavalent arsenic. It will not convert trivalent arsenic to pentavalent arsenic. The system was tested in a lab. Under those conditions, the system reduced 0.30 mg/L (ppm) pentavalent arsenic to 0.010 mg/L (ppm)(the USEPA standard for drinking water) or less. The performance of the system may be different at your installation. Have the treated water tested for arsenic to check if the system is working properly.

The RO component of the RO-3500 system must be replaced every 12-24 months to ensure the system will continue to remove pentavalent arsenic. The component identification and locations where you can purchase the component are listed in the installation/operation manual.

State of California
Department of Health Services
**Water Treatment Device
Certificate Number**
03 - 1607
Date Issued: December 23, 2003

<u>Trademark/Model Designation</u> RO-3000	<u>Replacement Elements</u> ROM-230T ROR
---	--

Manufacturer: Pentek Filtration

The water treatment device(s) listed on this certificate have met the testing requirements pursuant to Section 116830 of the Health and Safety Code for the following health related contaminants:

<u>Microbiological Contaminants and Turbidity</u> Cysts Turbidity	<u>Inorganic/Radiological Contaminants</u> Copper Fluoride Lead Selenium
---	--

<u>Organic Contaminants</u> None	
-------------------------------------	--

<u>Rated Service Capacity:</u> not applicable	<u>Rated Service Flow:</u> 7.6 gpd
---	------------------------------------

Conditions of Certification:
Do not use where water is microbiologically unsafe or with water of unknown quality, except that systems certified for cyst reduction may be used on disinfected waters that may contain filterable cysts.

State of California
Department of Health Services
**Water Treatment Device
Certificate Number**
03 - 1608
Date Issued: December 23, 2003

<u>Trademark/Model Designation</u> RO-3500	<u>Replacement Elements</u> ROM-230TN ROR
---	---

Manufacturer: Pentek

The water treatment device(s) listed on this certificate have met the testing requirements pursuant to Section 116830 of the Health and Safety Code for the following health related contaminants:

<u>Microbiological Contaminants and Turbidity</u> Cysts Turbidity	<u>Inorganic/Radiological Contaminants</u> Arsenic ¹ Barium Cadmium Chromium (hexavalent) Chromium (trivalent) Copper Fluoride Lead Nitrate/Nitrite ² Radium 226/228 Selenium
---	--

<u>Organic Contaminants</u> None	
-------------------------------------	--

<u>Rated Service Capacity:</u> not applicable	<u>Rated Service Flow:</u> 7.6 gpd
---	------------------------------------

Conditions of Certification:
Do not use where water is microbiologically unsafe or with water of unknown quality, except that systems certified for cyst reduction may be used on disinfected waters that may contain filterable cysts.

¹ Claims for arsenic reduction shall only be made on water supplies maintaining detectable residual free chlorine at the reverse osmosis (RO) system inlet. Water systems using an in-line chlorinator should provide a minimum of 1 minute chlorine contact time before the RO system.

² This system is acceptable for treatment of influent concentrations of no more than 27 mg/L nitrate and 3 mg/L nitrite in combination measured as N and is certified for nitrate/nitrite reduction only for water supplies with a pressure of 280 kPa (40 psig) or greater. A sampling and analysis test kit for nitrate is provided for checking the performance of this system. Frequent analysis is encouraged.

PENTEK ONE YEAR LIMITED WARRANTY

Pentek warrants to the original owner (under normal use): Reverse Osmosis Systems to be free from defects in material and/or workmanship one (1) year from the date of purchase. Any replacement products furnished will be free from defects in material and/or workmanship for the remainder of the original warranty period. This warranty does not cover: (1) pre and post filter cartridges, or reverse osmosis membrane (2) defects not reported within the above time period, (3) items manufactured by other companies, (4) problems arising from failure to comply with Pentek instructions, (5) problems and/or damage arising from acts of nature, abuse, misuse, negligence or accident by any party other than Pentek, (6) problems and/or damage resulting in whole or in part from alteration, modification, repair or attempted alteration, modification or repair by any party other than Pentek, (7) noncompliance with applicable codes/ordinances.

If a defect in workmanship and/or material in a product or part covered by the warranty should arise, Pentek, at its sole discretion, will repair or replace the defective product or part (Pentek may consider, in good faith, the customer's preference).

All claimed defective product must: (1) be authorized for return by Pentek with an RGA number (2) include proof of the purchase date of the product or part (3) returned to Pentek prior to the expiration of the warranty date, at the customer's expense, shipment pre-paid, (4) be accompanied by a letter detailing the Model Number, Serial Number (if any), and a brief description of the problem.

TO THE MAXIMUM EXTENT PERMITTED BY APPLICABLE LAW, PENTEK DISCLAIMS ALL OTHER WARRANTIES, WHETHER EXPRESS OR IMPLIED, INCLUDING, BUT NOT LIMITED TO, THE IMPLIED WARRANTY OF MERCHANTABILITY AND FITNESS FOR A PARTICULAR PURPOSE, WITH REGARD TO THE PRODUCTS, PARTS AND ANY ACCOMPANYING WRITTEN MATERIALS.

To the maximum extent permitted by applicable law, Pentek shall not be liable for any damages whatsoever (including, but not limited to, loss of time, inconvenience, expenses, labor or material charges incurred in connection with the removal or replacement of the Reverse Osmosis System, special, incidental, consequential, or indirect damages for personal injury, loss of business profits, business interruption, loss of business information, or any other pecuniary loss) arising out of the use of or inability to use the defective products or parts, even if Pentek has been advised of the possibility of such damages.

Penteks' maximum liability under any provision of this Limited Warranty shall be limited to the amount actually paid for the Reverse Osmosis System.

NOTE: Because some states do not allow the exclusion or limitation of incidental or consequential damages, the above limitations or exclusions may not apply.

THIS WARRANTY GRANTS SPECIFIC LEGAL RIGHTS, AND OTHER RIGHTS MAY APPLY. SUCH RIGHTS VARY FROM STATE TO STATE.

IOWA RESIDENTS ONLY:

Store or seller's name

Address

City State Zip

Telephone

Seller's signature

Customer's signature Date



502 Indiana Ave • Sheboygan, WI 53081
Toll Free Technical Support: 800-861-8758 • Technical Support: 920-451-9301
supportspecialist@pentekfiltration.com • www.pentekfiltration.com
Phone: 920-457-9434 • International Fax: 920-457-2417
www.international@pentekfiltration.com