

**MODEL #87-550 ASSEMBLY INSTRUCTIONS  
MODÈLE #87-550 INSTRUCTIONS D'ASSEMBLAGE  
MODELO #87-550 INSTRUCCIONES DE ASAMBLEA**

**STEP 2:** Attach pieces C to piece A.

**ÉTAPE 2:** Fixer la pièces C à la pièce A.

**PASO 2:** Adjuntar piezas C a pieza A.

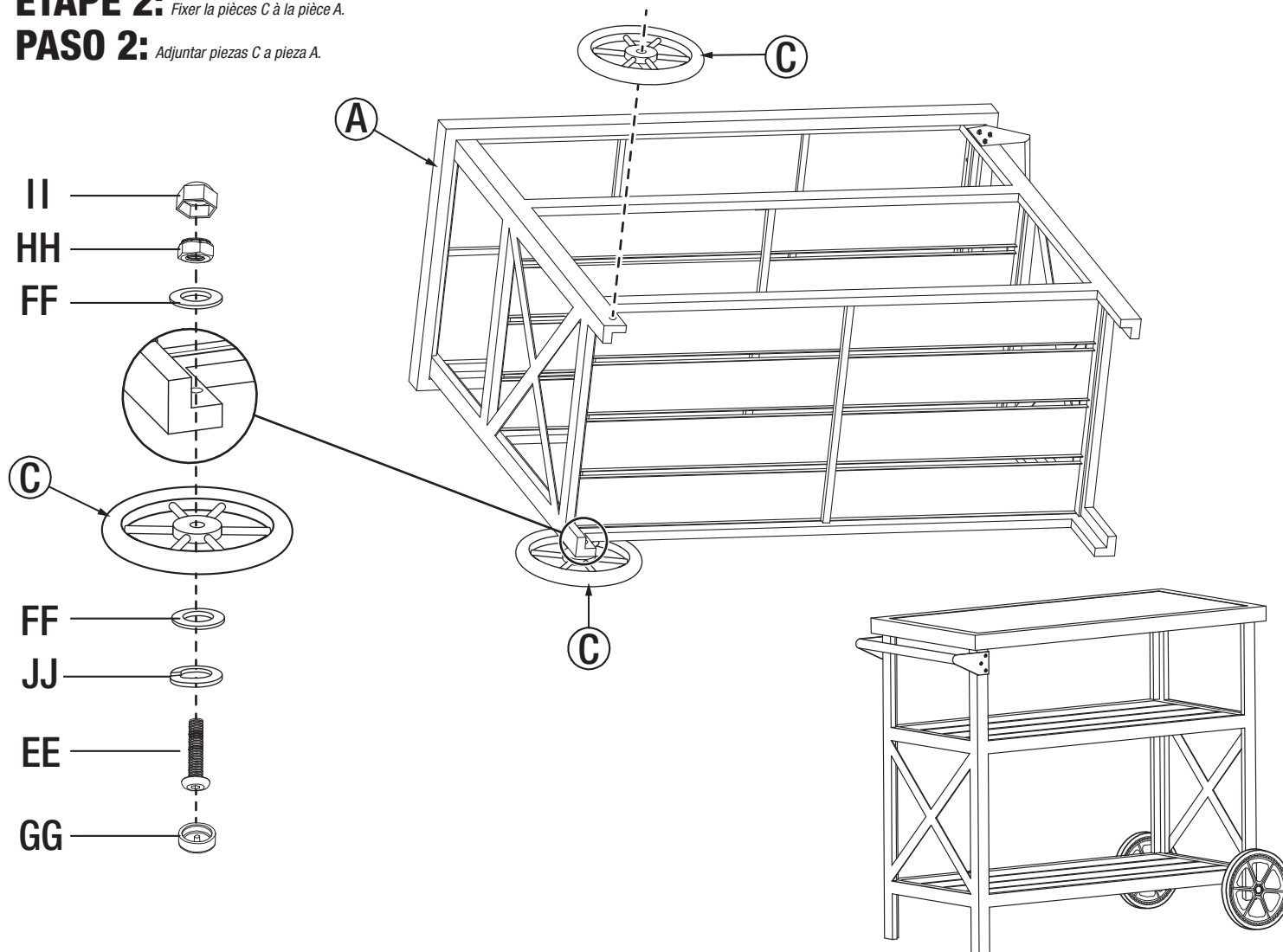

**CARE AND CLEANING:**

1. TO CLEAN, WIPE WITH DAMP CLOTH. DO NOT USE BLEACH, ACID SOLVENTS OR ABRASIVE CLEANERS ON FRAME PARTS.
2. DURING VARYING WEATHER CONDITIONS AND WINTER PERIOD, WE STRONGLY RECOMMEND THAT THE UNIT BE STORED IN A DRY AREA WITH A SUITABLE COVER. BEFORE STORAGE, PLEASE ENSURE THE UNIT IS CLEAN AND DRY.
3. PERIODICALLY CHECK AND ENSURE THAT ALL THE SCREWS ARE COMPLETELY TIGHTENED.
4. DO NOT STAND OR CLIMB ON UNIT.

**SOIN ET ENTRETIEN:**

1. POUR NETTOYER, ESSUYEZ AVEC UN CHIFFON HUMIDE. NE PAS UTILISER D'EAU DE JAVEL, DE SOLVANTS ACIDES OU DE NETTOYANTS ABRASIFS SUR PIÈCES DU CADRE.
2. LORS DE CONDITIONS MÉTÉOROLOGIQUES CHANGEANTES ET PENDANT L'HIVER, NOUS RECOMMANDONS FORTEMENT D'ENTREPOSER LE MEUBLE DANS UN ENDROIT SEC RECOUVERT D'UNE COUVERTURE APPROPRIÉE. AVANT D'ENTREPOSER, S.V.P. VEUILLEZ VOUS ASSURER QUE LE MEUBLE EST PROPRE ET SEC.
3. PÉRIODIQUEMENT, VÉRIFIEZ ET ASSUREZ-VOUS QUE TOUTES LES VIS SONT SERRÉES COMPLÈTEMENT.
4. NE PAS MONTER OU GRIMPER SUR LE MEUBLE.

**CUIDADO Y LIMPIEZA:**

1. PARA LIMPIAR, LIMPIE CON UN PAÑO HÚMEDO. NO UTILICE BLANQUEADOR, DISOLVENTES ACIDOS O LIMPIADORES ABRASIVOS EN PARTES DEL MARCO.
2. DURANTE CONDICIONES DE CLIMA VARIABLES Y PERIODOS DE INVIERNO, RECOMENDAMOS FIRMEMENTE QUE LA UNIDAD SEA GUARDADA EN UNA AREA SECA CON UNA COBERTURA ADECUADA. ANTES DE GUARDAR, FAVOR DE ASEGURAR QUE LA UNIDAD ESTÉ LIMPIA Y SECA.
3. PERIÓDICAMENTE COMPRUEBE Y ASEGÚRESE QUE TODOS LOS TORNILLOS ESTÉN COMPLETAMENTE APRETADOS.
4. NO SE PARE O SUBA EN LA UNIDAD.

See other great outdoor furniture by Cosco at [www.coscooutdoor.com](http://www.coscooutdoor.com) 4358-7377  
Voir d'autres meubles d'extérieur par Cosco à [www.coscooutdoor.com](http://www.coscooutdoor.com)  
Visite nuestra página [www.coscooutdoor.com](http://www.coscooutdoor.com) para ver otros grandes productos de Cosco

**MODEL #87-550 ASSEMBLY INSTRUCTIONS  
MODÈLE #87-550 INSTRUCTIONS D'ASSEMBLAGE  
MODELO #87-550 INSTRUCCIONES DE ASAMBLEA**



**READ & SAVE BELOW INSTRUCTIONS BEFORE ASSEMBLY**

1. PLEASE SEPARATE AND IDENTIFY ALL PARTS, MAKING SURE THAT YOU HAVE ALL OF THE PARTS LISTED.
2. TO AVOID ANY SCRATCHES DURING ASSEMBLY, PLEASE ASSEMBLE ON A SOFT MAT OR SIMILAR.
3. FOLLOW STEP BY STEP INSTRUCTIONS.
4. WASHERS MUST BE USED.
5. DO NOT TIGHTEN SCREWS UNTIL ALL THE SCREWS AND WASHERS ARE PROPERLY INSTALLED.
6. TIGHTEN SCREWS SECURELY, DO NOT OVER TIGHTEN.



**LIRE & CONSERVER LES INSTRUCTIONS CI-DESSOUS AVANT D'ASSEMBLER**













1. SÉPAREZ ET IDENTIFIEZ TOUTES LES PIÈCES, EN VOUS ASSURANT D'AVOIR TOUTES LES PIÈCES INDIQUÉES.
2. POUR ÉVITER LES RAYURES PENDANT L'ASSEMBLAGE, VEUILLEZ ASSEMBLER SUR UNE CARPETTE DOUCE OU UNE SURFACE SIMILAIRE.
3. SUIVEZ LES INSTRUCTIONS ÉTAPE PAR ÉTAPE.
4. LES RONDELLES DOIVENT ÊTRE UTILISÉES.
5. NE PAS SERRER LES VIS JUSQU'À CE QUE TOUTES LES VIS ET LES RONDELLES SOIENT INSTALLÉES CORRECTEMENT.
6. SERREZ LES VIS SOLIDEMENT, NE PAS SERRER EXCESSIVEMENT.





**GUARDAR Y LEER INSTRUCCIONES ANTES DE ARMAR**

1. POR FAVOR SEPARA E IDENTIFIQUE TODAS LAS PARTES, ASEGURÁNDOSE QUE TIENE TODAS LAS PIEZAS INDICADAS.
2. PARA EVITAR CUALQUIER RASGUÑO DURANTE LA ASAMBLEA, FAVOR DE ARMAR SOBRE UNA SUPERFICIE SUAVE.
3. SIGA LAS INSTRUCCIONES PASO POR PASO.
4. LAS ARANDELAS DEBEN SER USADAS.
5. NO APRETAR LOS TORNILLOS HASTA QUE TODOS LOS TORNILLOS Y LAS ARANDELAS HAYAN SIDO INSTALADOS.
6. APRETAR LOS TORNILLOS SEGURAMENTE, NO APRETAR EN EXCESO.

**HARDWARE LIST  
LISTE DE QUINCAILLERIE  
LISTA DE HERRAMIENTAS**

| CODE<br>CÓDIGO                     | PARTS<br>PARTES  | QTY<br>QTE<br>CANT |
|------------------------------------|--|--------------------|
| <b>HANDLE / MANIPULER / MANIJA</b> |  |                    |
| AA                                 | <br>M6 x 15 | 6                  |
| BB                                 |             | 6                  |
| CC                                 |             | 6                  |
| DD                                 | <br>M6      | 1                  |
| <b>WHEEL / ROUE / RUEDA</b>        |  |                    |
| EE                                 | <br>M8 x 75 | 2                  |
| FF                                 |             | 4                  |
| GG                                 |             | 2                  |
| HH                                 |            | 2                  |
| II                                 |           | 2                  |
| JJ                                 |           | 2                  |
| KK                                 |           | 1                  |
| LL                                 | <br>M8    | 1                  |

**PARTS LIST  
LISTE DE PIÈCES  
LISTA DE PARTES**

| CODE<br>CÓDIGO | PARTS<br>PARTES  | QTY<br>QTE<br>CANT |
|----------------|--|--------------------|
| A              | <br>(cart)<br>(chariot)<br>(carro)      | 1                  |
| B              | <br>(handle)<br>(manipuler)<br>(manija) | 1                  |
| C              | <br>(wheel)<br>(roue)<br>(rueda)        | 2                  |

**STEP 1:** Attach piece B to piece A.

**ÉTAPE 1:** Fixer la pièce B à la pièce A.

**PASO 1:** Adjuntar pieza B a pieza A.

