

The new ALL-PRO™ LED Dusk to Dawn Wall Pack is a dependable and reliable security lighting solution to the 26W compact fluorescent, Metal Halide, and High Pressure Sodium fixtures. It offers the same aesthetically pleasing look with the superior performance of a LED solution. This LED Wall Pack uses less power and has maintenance free LEDs, resulting in maintenance and energy savings. This product is an easy to install, high quality and durable LED lighting solution ideal for residential and commercial applications.



LED Wall Pack

- High impact, weather resistant housing and lens
- Maintenance – free LEDs with 50,000 hours of life
- 3500K and 5000K Color Temperature options
- Area coverage equivalence up to 100W incandescent or 26W CFL
- Integral photo control provides nighttime ON/daytime OFF
- cULus listed for wet locations
- Ideal for residential and light commercial applications
- 5 year limited warranty



Dusk to Dawn

MODEL#	PRODUCT DESCRIPTION	UPC	UNIT CARTON DIMENSIONS (IN.)	MASTER CARTON	MASTER CARTON DIMENSIONS (IN.)
WP1135LPC	LED Dusk to Dawn Wall Pack	0 80083 76039 8	6.1"W x 11.34"H x 4.01"D	2Pk	12"W x 6.7"H x 8.7"D
WP1150LPC	LED Dusk to Dawn Wall Pack	0 80083 75416 8	6.1"W x 11.34"H x 4.01"D	2Pk	12"W x 6.7"H x 8.7"D

Product Specifications

MODEL#	VOLTAGE	POWER	LUMENS	EFFICACY LUMEN/WATT	LED CCT	CRI
WP1135LPC	120V	13.8W	1200	88	3500K	85
WP1150LPC	120V	13.6W	1100	87	5000K	85



Powering Business Worldwide

Eaton
1121 Highway 74 South, Peachtree City, GA 30269

© 2016 Eaton. All Rights Reserved. Publication No. SA502049EN. October 2016
www.eaton.com/lighting

Coverage

Coverage Area

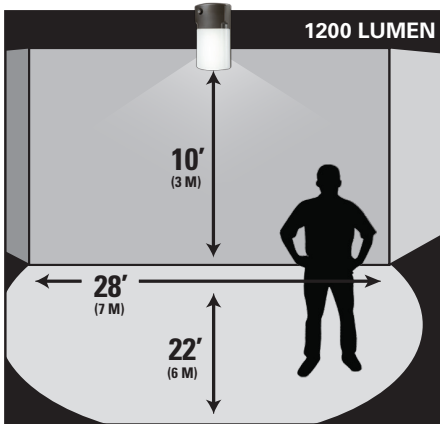

Features

Built-in automatic light sensor

High-impact weather resistant housing

Diffused lens provides "no glare" area lighting

Maintenance-free LEDs with 50,000 hours of life

