



# Engineered Wood

CONSTRUCTION GUIDE



©2011 APA – THE ENGINEERED WOOD ASSOCIATION • ALL RIGHTS RESERVED • ANY COPYING, MODIFICATION, DISTRIBUTION OR OTHER USE OF THIS PUBLICATION OTHER THAN AS EXPRESSLY AUTHORIZED BY APA IS PROHIBITED BY THE U.S. COPYRIGHT LAWS.

# WOOD

## The Natural Choice



*Engineered wood products are a good choice for the environment.* They are manufactured for years of trouble-free, dependable use. They help reduce waste by decreasing disposal costs and product damage. Wood is a renewable resource that is easily manufactured into a variety of viable products.

### A few facts about wood.

- **We're growing more wood every day.** Forests fully cover one-third of the United States' and one-half of Canada's land mass. American landowners plant more than two billion trees every year. In addition, millions of trees seed naturally. The forest products industry, which comprises about 15 percent of forestland ownership, is responsible for 41 percent of replanted forest acreage. That works out to more than one billion trees a year, or about three million trees planted every day. This high rate of replanting accounts for the fact that each year, 27 percent more timber is grown than is harvested. Canada's replanting record shows a fourfold increase in the number of trees planted between 1975 and 1990.



- **Life Cycle Assessment shows wood is the greenest building product.**

A 2004 Consortium for Research on Renewable Industrial Materials (CORRIM) study gave scientific validation to the strength of wood as a green building product. In examining building products' life cycles – from extraction of the raw material to demolition of the building at the end of its long lifespan – CORRIM found that wood was better for the environment than steel or concrete in terms of embodied energy, global warming potential, air emissions, water emissions and solid waste production. For the complete details of the report, visit [www.CORRIM.org](http://www.CORRIM.org).

- **Manufacturing wood is energy efficient.**

Wood products made up 47 percent of all industrial raw materials manufactured in the United States, yet consumed only 4 percent of the energy needed to manufacture all industrial raw materials, according to a 1987 study.

Material	Percent of Production	Percent of Energy Use
Wood	47	4
Steel	23	48
Aluminum	2	8



- **Good news for a healthy planet.** For every ton of wood grown, a young forest produces 1.07 tons of oxygen and absorbs 1.47 tons of carbon dioxide.

Wood: It's the natural choice for the environment, for design and for strong, lasting construction.



**NOTICE:**  
The recommendations in this guide apply only to products that bear the APA trademark. Only products bearing the APA trademark are subject to the Association's quality auditing program.

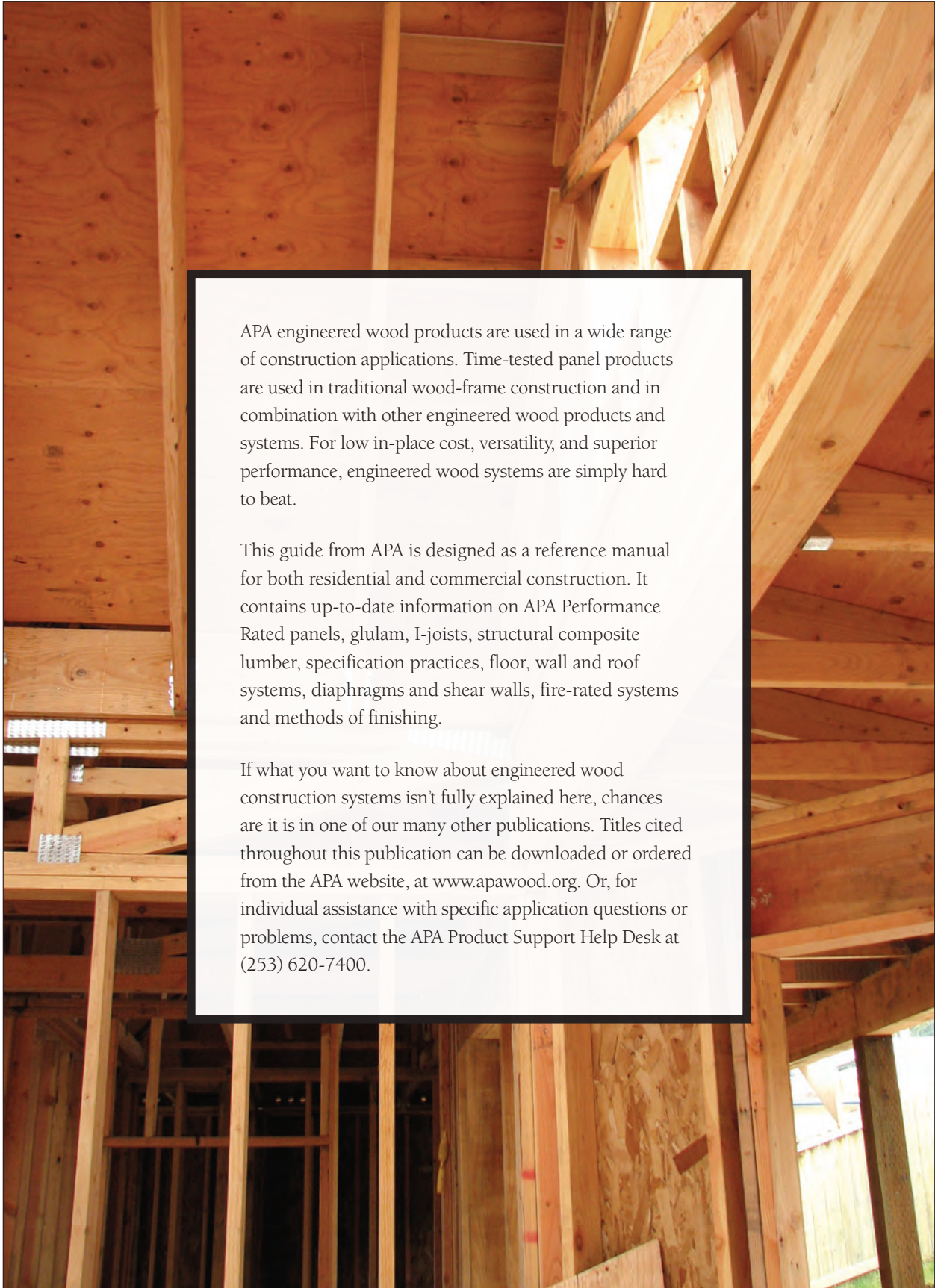

APA engineered wood products are used in a wide range of construction applications. Time-tested panel products are used in traditional wood-frame construction and in combination with other engineered wood products and systems. For low in-place cost, versatility, and superior performance, engineered wood systems are simply hard to beat.

This guide from APA is designed as a reference manual for both residential and commercial construction. It contains up-to-date information on APA Performance Rated panels, glulam, I-joists, structural composite lumber, specification practices, floor, wall and roof systems, diaphragms and shear walls, fire-rated systems and methods of finishing.

If what you want to know about engineered wood construction systems isn't fully explained here, chances are it is in one of our many other publications. Titles cited throughout this publication can be downloaded or ordered from the APA website, at [www.apawood.org](http://www.apawood.org). Or, for individual assistance with specific application questions or problems, contact the APA Product Support Help Desk at (253) 620-7400.





## WALL CONSTRUCTION

Building codes require that walls resist wind pressures caused by the design wind speeds, resist wall-racking forces and provide weather protection. This section provides details on how wood structural panels can be used to meet these fundamental requirements.

### APA Sturd-I-Wall®

The APA Sturd-I-Wall system consists of APA RATED SIDING (panel or lap) applied direct to studs or over nonstructural fiberboard, gypsum or rigid foam insulation sheathing\*. Nonstructural sheathing is defined as sheathing not recognized by building codes for meeting both bending and racking strength requirements.

\*Where panel siding is applied over foam sheathing, see APA publication *APA Rated Siding Panels over Rigid Foam Insulation Sheathing, Form C465*.

TABLE 19

### FASTENING APA RATED SIDING (PANEL) APPLIED DIRECT-TO-STUDS OR OVER NONSTRUCTURAL SHEATHING<sup>(a)(b)(c)(d)(e)</sup>

APA Rated Panel Siding	Minimum Nail <sup>(f)</sup>		Wall Stud Spacing (in. o.c.)	Panel Nail Spacing		Maximum Wind Speed (mph)		
	Shank Diameter (in.)	Penetration in Framing (in.)		Edges <sup>(g)</sup> (in. o.c.)	Intermediate Supports (in. o.c.)	Wind Exposure Category		
						B	C	D
3/8 Performance Category APA MDO GENERAL	0.113	1.5	16	6	12	110	90	90
			24	6	6	140	120	110
					6	12	90	NP
APA Rated Siding 16 oc	0.113	2.0	16	6	6	130	110	100
APA Rated Siding 24 oc			24	6	6	125	105	90
					6	12	100	85
					6	140	120	110

(a) Table is based on wind pressures acting toward and away from building surfaces, at 30-ft height in wall Zone 5 (corners) with smallest effective area, per Section 6.4.2.2 of ASCE 7-05 and Section R301.2 of the 2009 IRC. Stud specific gravity = 0.42.

(b) Recommendations of siding manufacturer may vary.

(c) For use as wood structural panel wall bracing, the minimum fastener spacing of 6" o.c. at panel edges and 12" o.c. at intermediate supports shall be sufficient except:

(1) For braced wall section with Performance Category 3/8 panel siding applied horizontally over studs 24" o.c., space nails 3" o.c. along panel edges.

(d) Hot-dip galvanized nails are recommended for most siding applications, see *Siding Fasteners* section on page 48 for more information.

(e) Maximum stud spacing shall be in accordance with Table 21A.

(f) See Table 5, page 14, for nail dimensions.

(g) Supported panel joints shall occur approximately along the centerline of framing with a minimum bearing of 1/2". Fasteners shall be located 3/8" from panel edges. Siding installed over two or more spans.

TABLE 20

**APA RATED LAP SIDING APPLIED DIRECT-TO-STUDS OR OVER NONSTRUCTURAL SHEATHING<sup>(a)(b)(c)(d)(e)</sup>**

Minimum Nail <sup>(f)</sup>		Minimum Performance Category (in.)	Wall Stud Spacing (in. o.c.)	Lap Siding Width (in.)	Maximum Wind Speed (mph)		
Shank Diameter (in.)	Penetration in Framing (in.)				Wind Exposure Category		
					B	C	D
0.113	1.5	3/8	16	6	140	120	110
				8	140	120	110
				12	120	100	90
		7/16	16	6	140	120	110
				8	140	120	110
				12	120	100	90
	7/16	24	6	140	120	110	
			8	120	100	90	
			12	90	NP	NP	

- (a) Table is based on wind pressures acting toward and away from building surfaces, at 30-ft height in wall Zone 5 (corners) with smallest effective area, per Section 6.4.2.2 of ASCE 7-05 and Section R301.2 of the 2009 IRC, Stud specific gravity = 0.42.
- (b) Recommendations of siding manufacturer may vary.
- (c) APA Rated lap siding rated 16 oc and 24 oc shall be used with a maximum stud spacing of 16" o.c. and 24" o.c., respectively.

- (d) Hot-dip galvanized nails are recommended for most siding applications, see Siding Fasteners section of page 48 for more information.
- (e) Supported panel joints shall occur approximately along the centerline of framing with a minimum bearing of 1/2". Fasteners shall be located 3/8" from panel edges. Siding installed over two or more spans.
- (f) See Table 5, page 14, for nail dimensions.

TABLE 21A

**MAXIMUM STUD SPACING: APA RATED SIDING (PANEL) APPLIED DIRECT-TO-STUDS OR STRUCTURAL SHEATHING**

Siding Description	Minimum Performance Category or Span Rating	Maximum Stud Spacing (in.) for Vertical Rows of Nails	
		Parallel to Supports	Perpendicular to Supports
APA MDO GENERAL	3/8	16	24
	15/32	24	24
APA Rated Siding	16 oc	16	16 <sup>(a)</sup>
	24 oc	24	24

- (a) Stud spacing may be 24" o.c. for veneer-faced siding panels.

TABLE 21B

**APA RATED SIDING (PANEL) APPLIED TO STRUCTURAL SHEATHING<sup>(a)(b)(c)(d)(e)</sup>**

APA Rated Panel Siding	Minimum Nail <sup>(f)(g)</sup>		Panel Nail Spacing		Maximum Wind Speed (mph)		
	Shank Diameter (in.)	Wall Stud Spacing (in. o.c.)	Edges <sup>(h)</sup> (in. o.c.)	Intermediate Supports (in. o.c.)	Wind Exposure Category		
					B	C	D
3/8 Performance Category APA MDO GENERAL	0.120 ring shank	16	6	12	110	90	85
				6	125	105	90
APA Rated Siding 16 oc or 24 oc		24	6	12	90	NP	NP
				6	110	90	85

- (a) Table is based on wind pressures acting toward and away from building surfaces, at 30-ft height in wall Zone 5 (corners) with smallest effective area, per Section 6.4.2.2 of ASCE 7-05 and Section R301.2 of the 2009 IRC, Stud specific gravity = 0.42.
- (b) Recommendations of siding manufacturer may vary.
- (c) For use as wood structural panel wall bracing, the minimum fastener spacing of 6" o.c. at panel edges and 12" o.c. at intermediate supports shall be sufficient.

- (d) Hot-dip galvanized nails are recommended for most siding applications, see Siding Fasteners section on page 48 for more information.
- (e) Maximum stud spacing shall be in accordance with Table 21A.
- (f) Ring shank nail shall be used.
- (g) See Table 5, page 14, for nail dimensions.
- (h) Supported panel joints shall occur approximately along the centerline of framing with a minimum bearing of 1/2". Fasteners shall be located 3/8" from panel edges.

A single layer of wood structural panel siding, since it is strong and rack resistant, eliminates the cost of installing separate structural sheathing or diagonal wall bracing. Panel sidings are normally installed vertically, but may also be placed horizontally (long dimension across supports) if horizontal joints are blocked. Maximum stud spacings for both applications are given in Tables 19, 20 and 21.

When installing panel or lap siding over rigid foam insulation sheathing, drive the nails flush with the siding surface, but avoid over-driving, which can result in dimpling of the siding due to the compressible nature of foam sheathing.

Sidings are occasionally treated with water repellents or wood preservatives to improve finishing characteristics or moisture resistance for certain applications. If the siding has been treated, allowing the surface treatment to dry will avoid solvent or chemical reaction with the foam sheathing.

When rigid foam insulation sheathing is used, building codes also generally require installation of 1/2-inch gypsum wallboard, or other materials of the required thermal barrier rating, on the inside surface of the wall for fire protection.

See Figures 8 through 12 for panel and lap siding installation recommendations for the Sturd-I-Wall system or for siding installed over nailable sheathing. See *APA's Build A Better Home: Walls, Form A530*, for additional recommended details to avoid moisture penetration in walls.

All panel siding edges in Sturd-I-Wall construction should be backed with framing or blocking. Use nonstaining, non-corrosive nails as described in Tables 19, 20 and 21 to prevent staining the siding.

Where siding is to be applied at an angle, install only over wood structural panel sheathing.

**Note:** Gluing of siding to framing is not recommended due to the increased potential for panel buckling.

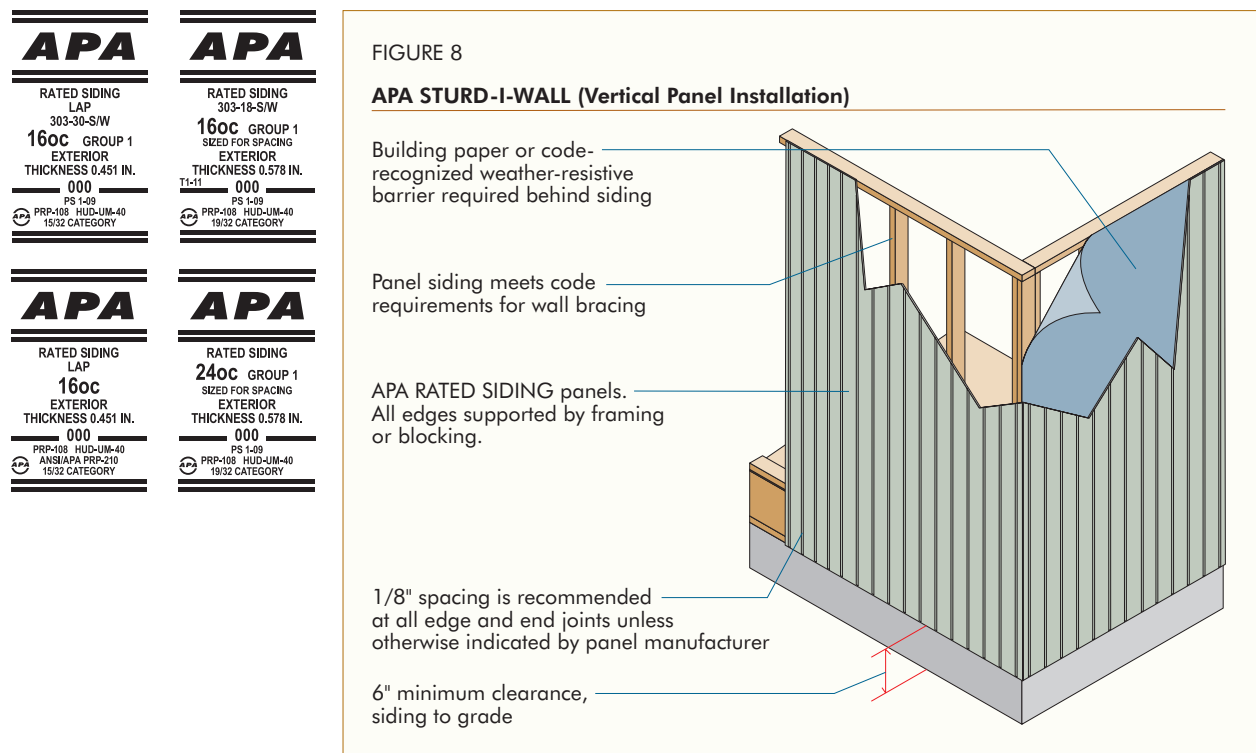

## Siding Fasteners

Hot-dip galvanized nails are recommended for most siding applications. For best performance, stainless steel or aluminum nails should be considered. APA tests also show that electrically or mechanically galvanized steel nails appear satisfactory when plating meets or exceeds thickness requirements of **ASTM A641 Class 2** coatings, and is further protected by yellow chromate coating. Note that galvanized fasteners may react under wet conditions with the natural extractives of some wood species and may cause staining if left unfinished. Such staining can be minimized if the siding is finished in accordance with APA recommendations, or if the roof overhang protects the siding from direct exposure to moisture and weathering.

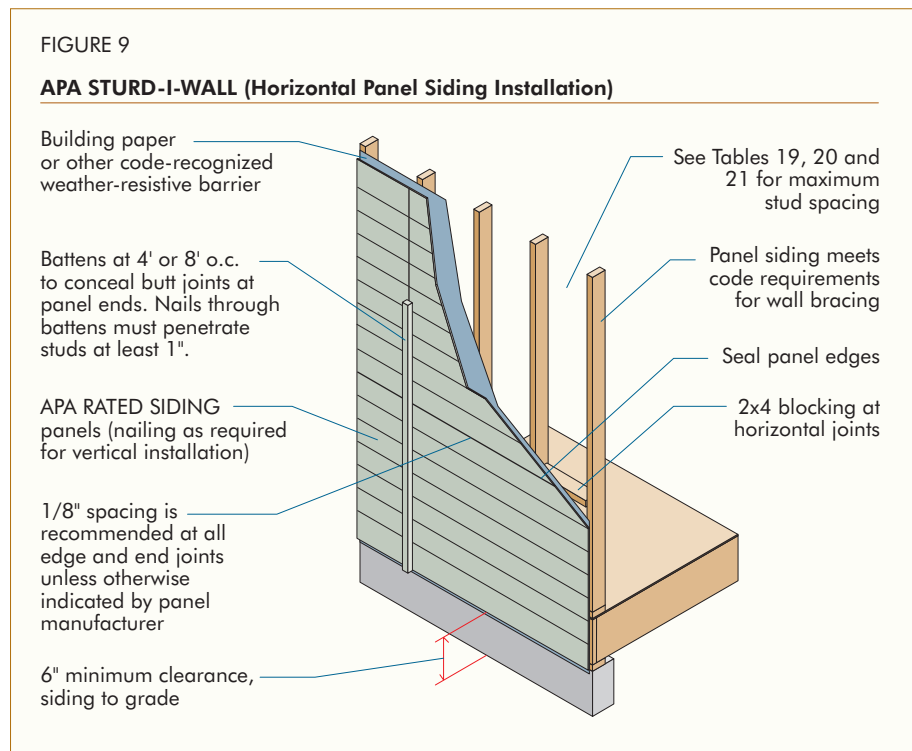

## Wood Structural Panel Sheathing as a Nail Base for Siding

The recommendations in Tables 22 and 23 for panel and lap siding apply to siding installed over wood structural panel sheathing. Unless otherwise indicated in the local building code, nailable sheathing includes:

1. Nominal 1-inch boards with studs 16 or 24 inches o.c.
2. APA RATED SHEATHING panels with roof Span Rating of 24 inches or greater installed with strength axis either parallel or perpendicular to studs 16 or 24 inches o.c. (except 3-ply plywood panels must be applied with strength axis across studs when studs are spaced 24 inches o.c.).
3. APA RATED SHEATHING panels with roof Span Rating less than 24 inches installed with strength axis either parallel or perpendicular to studs 16 inches o.c. (except plywood panels 3/8 Performance Category or less must be applied with strength axis across studs).

Lap siding joints, if staggered, and panel siding joints may occur away from studs with wood structural panel sheathing.

**Note:** In addition to panel edge spacing and the use of straight studs, nailing sequence can also be a factor in maintaining a uniformly flat appearance of the finished wall. Installation procedure: First, position the panel, maintaining recommended edge spacing, and lightly tack at each corner. Install the first row of nails at the edge next to the preceding panel from top to bottom. Remove remaining tacking nails. Then nail the row at the first intermediate stud. Continue by nailing at the second intermediate stud, and finally, at the edge opposite the preceding panel. Complete the installation by fastening to the top and bottom plates.

For other fastener types, refer to Table 22. It provides the withdrawal resistance for a number of different fastener types (smooth-, ring- and screw-shank nails; wood screws and vinyl siding nails). Together with the [wind load tables](#) in the 2006 and 2009 International Residential Codes, [IRC Tables R301.2\(2\) and R301.2\(3\)](#), the attachment schedules for any combination of siding type, continuous wood structural panel sheathing, design wind speed and exposure can be determined. See [APA Technical Topic: Wood Structural Panels Used as Nailable Sheathing, Form TT-109](#) for more information including wind load tables and a sample calculation.

TABLE 22

**FASTENER WITHDRAWAL LOADS FOR THE ATTACHMENT OF SIDING TO CONTINUOUS WOOD STRUCTURAL PANEL WALL SHEATHING<sup>(a)</sup>**

<b>Ring-Shank Nails<sup>(b)(c)</sup> Withdrawal Loads (lbf)</b>								
Wall Sheathing Performance Category	Nail Diameter (in.)							
	0.091	0.094	0.097	0.113	0.120	0.128	0.135	0.148
3/8	31	32	33	38	41	43	46	50
7/16	36	37	38	45	48	51	53	59
15/32 and 1/2	39	40	41	48	51	54	57	63
19/32 and 5/8	49	51	52	61	64	69	73	80
23/32 and 3/4	59	61	63	74	78	83	88	96

<b>Wood Screws<sup>(c)(d)</sup> Withdrawal Loads (lbf)</b>							
Wall Sheathing Performance Category	Screw Gauge/Diameter (in.)						
	#6	#7	#8	#9	#10	#12	#14
3/8	48	52	57	61	66	75	84
7/16	56	61	66	72	77	87	98
15/32 and 1/2	60	65	71	77	82	93	105
19/32 and 5/8	76	83	90	97	104	118	133
23/32 and 3/4	92	100	109	117	126	143	161

<b>Smooth-Shank and Screw-Shank Nails<sup>(c)(e)</sup> Withdrawal Loads (lbf)</b>									<b>Vinyl Siding Nails<sup>(c)(e)(f)</sup> Withdrawal Loads</b>	
Wall Sheathing Performance Category	Nail Diameter (in.)								Nail Diameter (in.)	
	0.092	0.099	0.113	0.120	0.128	0.131	0.135	0.148	0.122	0.125
3/8	8	8	9	10	11	11	11	12	10	10
7/16	9	10	11	12	13	13	13	14	12	12
15/32 and 1/2	10	10	12	13	13	14	14	16	13	13
19/32 and 5/8	12	13	15	16	17	17	18	20	16	17
23/32 and 3/4	15	16	18	19	21	21	22	24	20	20

- (a) Withdrawal capacities are based on the duration of load factor of 1.6 for wind applications. Adjustments for wet service and temperature are normally not required for attachment to the wood structural panel nailable sheathing.
- (b) For ring-shank nails, the withdrawal capacities (W) are based on specific gravities (G) of 0.70 in accordance with [APA TT-039](#) and  $W = 1380 G^{2.5} D C_D t$ , where: W = Withdrawal capacity (lbf), G = Specific Gravity, D = Nail diameter (in.),  $C_D$  = Duration of load factor (1.6 for wind loads), and t = wood structural panel thickness (in.).
- (c) Fasteners shall be long enough to fully penetrate wood structural panel sheathing by at least 1/4 inch.
- (d) For wood screws, the withdrawal capacities (W) are based on specific gravities (G) of 0.45 in accordance with [APA TT-051](#) and  $W = 2850 G^2 D C_D t$ , where: W = Withdrawal capacity (lbf), G = Specific Gravity, D = Nail diameter (in.),  $C_D$  = Duration of load factor (1.6 for wind loads), and t = wood structural panel thickness (in.).
- (e) For smooth-shank, screw-shank, and vinyl siding nails, the withdrawal capacities (W) are based on specific gravities (G) of 0.40 in accordance with [APA TT-039](#) and  $W = 1380 G^{2.5} D C_D t$ , where: W = Withdrawal capacity (lbf), G = Specific Gravity, D = Nail diameter (in.),  $C_D$  = Duration of load factor (1.6 for wind loads), and t = wood structural panel thickness (in.).
- (f) Vinyl siding nails shall have a head of at least 3/8 inch in diameter.



FIGURE 10

**APA STURD-I-WALL (Horizontal Lap Siding Installation)<sup>(a)</sup>**

Building paper or other code-recognized weather-resistive barrier required

Leave 1/8" spacing and caulk vertical joints unless otherwise recommended by siding manufacturer

APA RATED SIDING (lap siding), maximum width 12". Minimum headlap 1".

6" minimum clearance, siding to grade

1-1/2"-wide starter strip, thickness to match lap siding

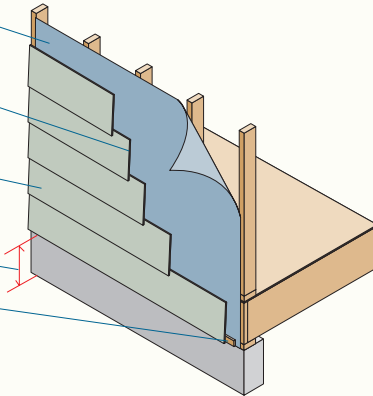

(a) For engineered shear wall segments or wall bracing requirements, use APA Rated Sheathing for wall sheathing under lap siding (see Figure 12). Other methods permitted by model building codes for braced wall segments may also be used.

FIGURE 11

**APA RATED SIDING (PANEL SIDING) OVER WOOD STRUCTURAL PANEL SHEATHING**

Building paper or other code-recognized weather-resistive barrier required

APA RATED SIDING panels applied over sheathing

6" minimum clearance, siding to grade

1/8" spacing is recommended at all edge and end joints unless otherwise indicated by panel manufacturer

Panel siding or APA RATED SHEATHING meets code requirement for wall bracing

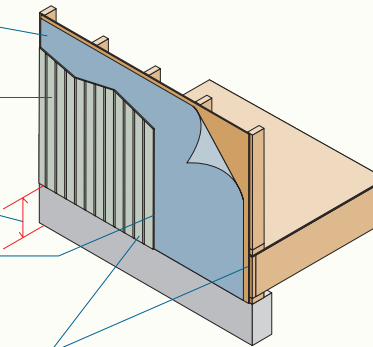

FIGURE 12

**APA RATED SIDING (LAP SIDING) OVER WOOD STRUCTURAL PANEL SHEATHING**

APA RATED SHEATHING meets code requirement for wall bracing

Building paper or other code-recognized weather-resistive barrier required

APA RATED SIDING (lap siding), maximum width 12". Minimum headlap 1".

Siding joints, if staggered may occur away from studs with nailable sheathing

6" minimum clearance, siding to grade

Leave 1/8" spacing and caulk vertical joints, unless otherwise recommended by siding manufacturer

1-1/2"-wide starter strip, thickness to match lap siding

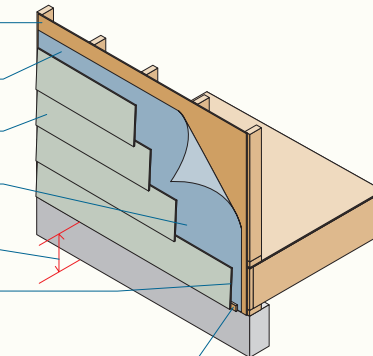

TABLE 23

**APA RATED LAP SIDING APPLIED DIRECT-TO-STUDS OR OVER STRUCTURAL SHEATHING<sup>(a)(b)(c)</sup>**

Minimum Nail Shank Diameter <sup>(d)</sup> (in.)	Minimum Performance Category Lap Siding	Fastener Spacing (in.) <sup>(e)</sup>	Lap Siding Width (in.)	Maximum Wind Speed (mph)		
				Wind Exposure Category		
				B	C	D
0.113	3/8	6	6	130	110	100
			8	110	90	85
			12	85	NP	NP

(a) Table is based on wind pressures acting toward and away from building surfaces, at 30-ft height in wall Zone 5 (corners) with smallest effective area, per Section 6.4.2.2 of ASCE 7-05 and Section R301.2 of the 2009 IRC, Stud specific gravity = 0.42.

(b) Recommendations of siding manufacturer may vary.

(c) Hot-dip galvanized nails are recommended for most siding applications, see Siding Fasteners section on page 48 for more information.

(d) See Table 5, page 14, for nail dimensions.

(e) Fastener spacing at top edge of lap siding.

TABLE 24

**APA RATED SHEATHING APPLIED DIRECT-TO-STUDS<sup>(a)(b)</sup>**

Minimum Nail <sup>(c)</sup>		Minimum Wood Structural Panel Span Rating	Minimum Panel Performance Category	Wall Stud Spacing (in.)	Panel Nail Spacing		Maximum Wind Speed (mph)		
Shank Diameter (in.)	Minimum Penetration (in.)				Edges (in. o.c.)	Field (in. o.c.)	Wind Exposure Category		
						B	C	D	
0.113	1.5	24/0, Wall-16 and Wall-24	3/8	16	6	12	110	90	85
						6	110	100	90
0.131	1.75	24/16, Wall-24	7/16	16	6	12	130	110	105
						6	150	125	110
						24 or less	110	90	85
						12	150	125	110



(a) Panel strength axis parallel or perpendicular to supports. Three-ply plywood sheathing with studs spaced more than 16" on center shall be applied with panel strength axis perpendicular to supports.

(b) Table is based on wind pressures acting toward and away from building surfaces, at 30-ft height in wall Zone 5 (corners) with smallest effective area, per Section 6.4.2.2 of ASCE 7-05 and Section R301.2 of the 2009 IRC, Stud specific gravity = 0.42.

(c) See Table 5, page 14, for nail dimensions.

### APA Panel Wall Sheathing

APA RATED SHEATHING meets building code wall sheathing requirements for wind pressures and wall bracing. Even when foam or other nonstructural sheathing is used, APA RATED SHEATHING corner bracing panels (Figure 14) of the same thickness meet code wall bracing requirements. Installation recommendations are given in Figure 13 and Table 24.

 <b>RATED SHEATHING</b> <b>24/0</b> SIZED FOR SPACING EXPOSURE 1 THICKNESS 0.354 IN. 000 PS 2-10 SHEATHING PRP-108 HUD-UM-40 3/8 CATEGORY	 <b>RATED SHEATHING</b> <b>24/16</b> SIZED FOR SPACING EXPOSURE 1 THICKNESS 0.418 IN. 000 PS 2-10 SHEATHING PRP-108 HUD-UM-40 7/16 CATEGORY	 <b>RATED SHEATHING</b> <b>STRUCTURAL I</b> <b>32/16</b> SIZED FOR SPACING EXPOSURE 1 THICKNESS 0.451 IN. 000 PS 1-09 C-D PRP-108 15/32 CATEGORY
--	---	--

Recommended wall sheathing spans with brick veneer or masonry are the same as those for panel sheathing (see Table 24). See Figure 15 for installation recommendations.

Panel recommendations for preframed wall sections are the same as for built-in-place walls.

**Note:** To minimize the potential for panel buckling, gluing of wall sheathing to framing is not recommended, except when recommended by the adhesive manufacturer for wall sheathing that already has been permanently protected by siding.

**FIGURE 13**  
**APA PANEL WALL SHEATHING**

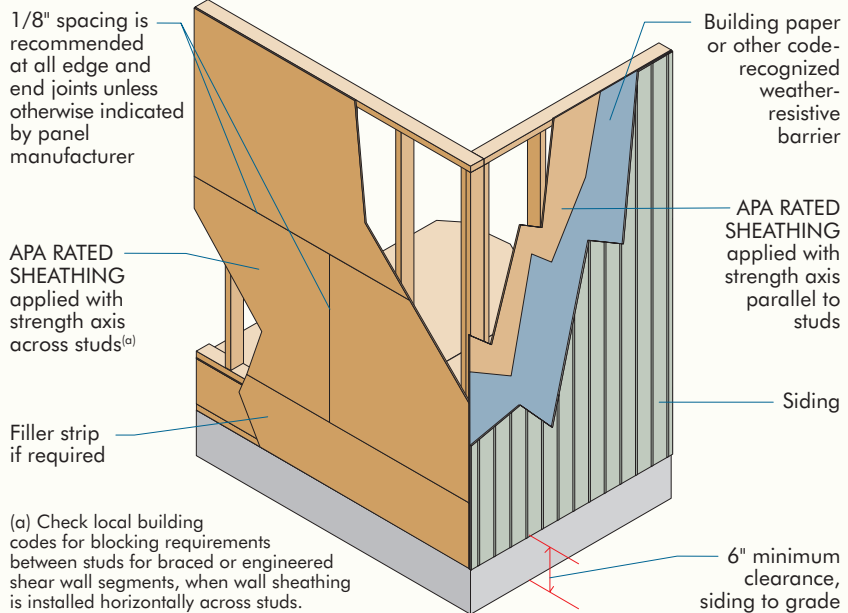

**FIGURE 14**  
**APA PANEL CORNER BRACING**

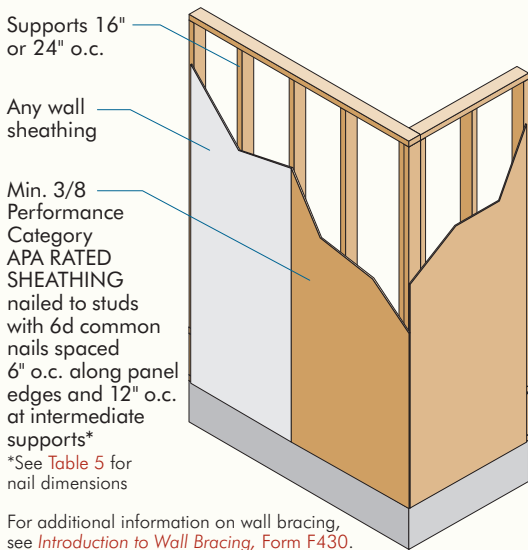

**FIGURE 15**  
**BRICK VENEER OVER APA PANEL SHEATHING**

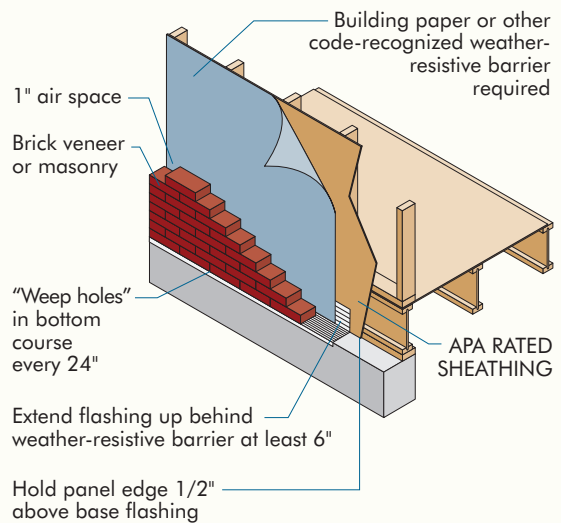

### APA Sheathing Under Stucco

Greater stiffness is recommended for wall sheathing when stucco is to be applied. To increase stiffness, apply the long panel dimension or strength axis across studs. Blocking or a plywood cleat is recommended at horizontal joints. Blocking is required for shear wall and wall bracing applications. For panel recommendations applied horizontally or vertically, see Table 25.

### Siding Joint Details

The siding joint details in Figure 17 are based on the use of APA trademarked siding. Nailing of wood structural panel siding along both edges of shiplap joints (“double nailing”), as shown, is required for shear walls or those wall segments that must meet bracing requirements. Double nailing is recommended for all other applications as well to provide maximum wall strength and moisture protection.

Where caulks or joint sealants are indicated, consider the various types available such as urethane, plasticized acrylic latex, butyl and polysulfide. Check with the manufacturer of the caulk or sealant to determine suitability for the intended application and compatibility with coatings and other building materials such as vinyl and aluminum.

In some cases, a foam backer rod or other type filler material may be used behind the sealants as recommended by the manufacturer. For best results in other cases, apply caulking to framing at panel edges before installing the siding panel; or apply a bead of caulk along the panel edge before installing the next panel. A 1/8-inch space is recommended at all edge and end joints unless otherwise indicated by panel manufacturer. If caulk is to be used, also check with caulk manufacturer for recommended edge spacing. Nails through battens or other wood trim must penetrate at least 1 inch into studs. Nail panel siding 6 inches o.c. along edges and 12 inches o.c. at intermediate supports. To prevent staining of siding, use hot-dip galvanized, aluminum, or other nonstaining nails as described on page 48.

Siding is often fully exposed to weather and thus has increased susceptibility to elevated moisture conditions. Although siding will periodically experience moisture contents above the threshold value needed to support decay, wood-based siding products have a good history of performance because they dry below this threshold value before decay can initiate. If trim is installed around siding, be sure that it doesn't trap moisture or reduce the drying ability of the wood. Trim that is applied incorrectly can lead to long-term moisture accumulation that causes decay.

Apply flashing or other means of protection over end grain of siding to minimize water absorption.

TABLE 25

#### RECOMMENDED THICKNESS AND SPAN RATING FOR APA PANEL WALL SHEATHING FOR STUCCO EXTERIOR FINISH

Stud Spacing (in.)	Panel Orientation <sup>(a)</sup>	APA Rated Sheathing <sup>(b)</sup>	
		Minimum Performance Category	Minimum Span Rating
16	Horizontal <sup>(c)</sup>	3/8	24/0
	Vertical	7/16 <sup>(d)</sup> 15/32 <sup>(e)</sup> , 1/2 <sup>(e)</sup>	24/16 32/16
24	Horizontal <sup>(c)</sup>	7/16	24/16
	Vertical	19/32 <sup>(e)</sup> , 5/8 <sup>(e)</sup>	40/20

(a) Strength axis (typically the long panel dimension) perpendicular to studs for horizontal application; or parallel to studs for vertical application.

(b) Recommendations apply to all-veneer plywood or oriented strand board (OSB) except as noted.

(c) Blocking recommended between studs along horizontal panel joints.

(d) Structural I Rated Sheathing (OSB).

(e) OSB or 5-ply/5-layer plywood.

FIGURE 16

#### STUCCO OVER APA PANEL SHEATHING

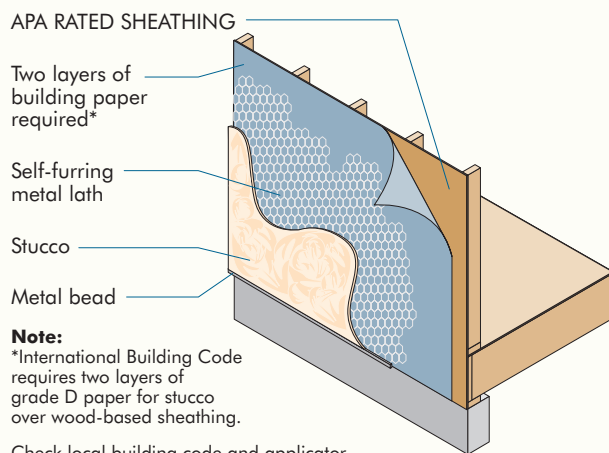

**Note:**  
\*International Building Code requires two layers of grade D paper for stucco over wood-based sheathing.

Check local building code and applicator for specific requirements.



FIGURE 17

**TYPICAL PANEL SIDING JOINT DETAILS**

(Note: Water-resistant barrier [building paper or house wrap] is required behind siding.)

**VERTICAL WALL JOINTS**

**Butt**

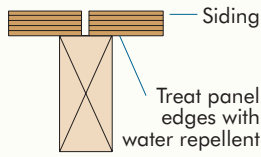

**Shiplap**

Reverse Board and Batten

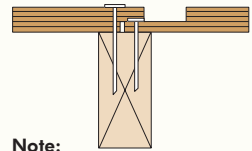

T1-11 & Channel Groove

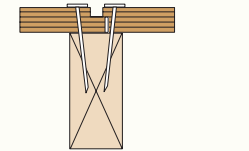

**Note:**

Nailing of both panel edges along shiplap joint is recommended. The "double nailing" is required when wall segment must meet wall bracing or engineered shear wall requirements.

**Vertical Batten**

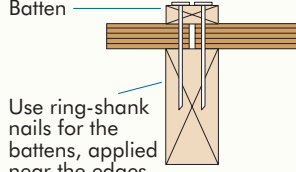

Use ring-shank nails for the battens, applied near the edges in two staggered rows

**VERTICAL INSIDE & OUTSIDE CORNER JOINTS**

**Butt & Caulk**

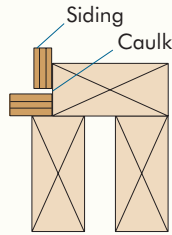

**Corner Board Lap Joints**

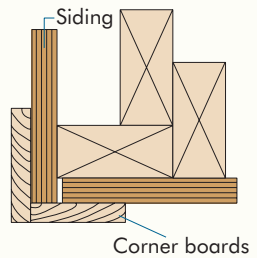

**Lap Siding (APA Sturd-I-Wall)**

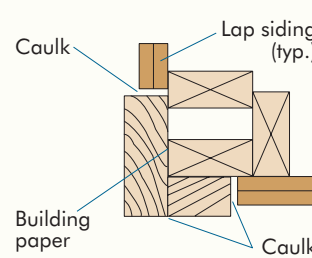
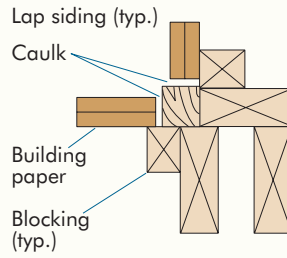

**HORIZONTAL WALL JOINTS**

**Butt & Flash**

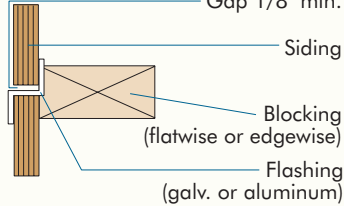

**Lap**

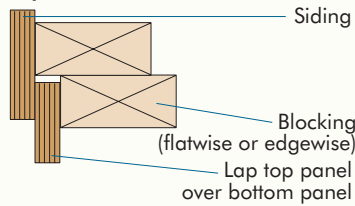

**Shiplap**

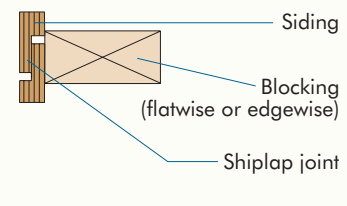

**HORIZONTAL BELTLINE JOINTS**

(For multistory buildings, when conventional lumber floor joists and rim boards are used, make provisions at horizontal joints for shrinkage of framing, especially when applying siding direct to studs.)

**Jog Exterior Stud Line**

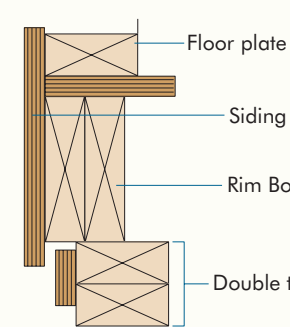

**Band Board Over Panel Filler**

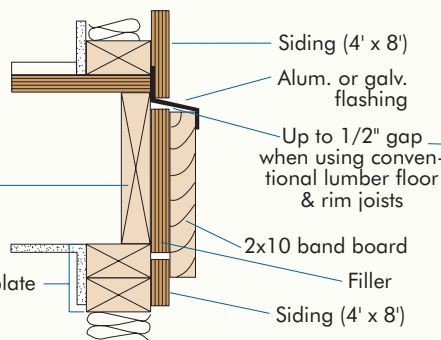

**Band Board In Relief**

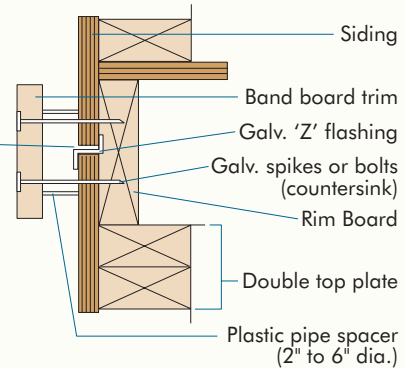

**WINDOW DETAILS**

(For window details, see *Build A Better Home: Walls, Form A530.*)

## APA Rated Siding Patterns and Grades

APA RATED SIDING, including 303 plywood siding, is available in a wide variety of surface textures and patterns. For descriptions of siding surface patterns and thicknesses, refer to *APA Product Guide: APA Performance Rated Sidings, Form E300*. Actual dimensions of groove spacing, width and depth may vary with the manufacturer. Where the characteristics of a particular wood species are desired, specify by grade and species preference.

In order to help specifiers select the most appropriate siding appearance for any particular job, APA 303 plywood sidings are also identified by a face grading system. There are four basic siding classifications within the system – Special Series 303, 303-6, 303-18 and 303-30. Each class, as shown in Table 26, is further divided into grades according to categories of repair and appearance characteristics.

### Finishing Plywood for Exterior Exposure

#### Care and Preparation

Plywood should be stored and handled with care to avoid damaging before finishing. Storage in a cool, dry place out of sunlight and weather is best. If left outdoors, straps on bundles should be loosened or cut and the plywood covered. Allow good air circulation to prevent moisture condensation and possible mold growth.

#### Edge Sealing

Moisture enters the end grain of plywood or other wood-based products faster than through the surface. Consequently, edges and ends of APA RATED SIDING panels or lap siding should be sealed. Although edge sealers are not necessarily moisture-proof or permanently durable, they help to minimize sudden changes in moisture content in the siding, due to weather.

APA RATED SIDING may be edge sealed at the factory. If the siding is not factory-sealed, it can be sealed quickly at the job site while the panels or lap siding pieces are still in a stack. Edges or ends cut during construction should be resealed.

Siding to be finished with a semitransparent or solid-color stain can be edge sealed with a liberal application of a paintable, water-repellent sealer. If the siding is to be painted, apply sealer to edges using the same paint primer that will be used on the surface. Horizontal edges, particularly lower drip edges of siding, should be carefully edge-sealed because of their greater wetting exposure.

TABLE 26

APA 303 SIDING FACE GRADES<sup>(a)</sup>

303 Series Plywood Siding Grades	Type of Patch	
	Wood	Synthetic
303-OC	Not permitted	Not permitted
303-OL	Not applicable for overlays	
303-NR	Not permitted	Not permitted
303-SR	Not permitted	Permitted as natural-defect shape
303-6-W	Limit 6	Not permitted
303-6-S	Not permitted	Limit 6
303-6-S/W	Limit 6 – any combination	
303-18-W	Limit 18	Not permitted
303-18-S	Not permitted	Limit 18
303-18-S/W	Limit 18 – any combination	
303-30-W	Limit 30	Not permitted
303-30-S	Not permitted	Limit 30
303-30-S/W	Limit 30 – any combination	

(a) All panels except 303-NR allow restricted minor repairs such as shims. These and such other face appearance characteristics as knots, knotholes, splits, etc., are limited by both size and number in

accordance with panel grades, 303-OC being most restrictive and 303-30 being least. Multiple repairs are permitted only on 303-18 and 303-30 panels. Patch size is restricted on all panel grades.

## Finishing

APA RATED SIDING may be finished with a variety of products such as semi-transparent stains, solid-color stains or paint systems. The recommended finishes depend on the type of siding product, and whether it has an overlaid surface.

Oil-based, semitransparent stains may be used on certain veneer-faced siding products as detailed in Table 27. Solid-color stains may be used on most APA RATED SIDING products and usually provide better protection. In general, however, best overall performance on APA RATED SIDING products can be achieved with an all-acrylic latex paint system.

For overlaid siding, any top-quality exterior house paint system formulated for wood performs satisfactorily. Solid-color stains may also be used on overlaid sidings, although some manufacturers recommend only acrylic latex formulations. For specific recommendations on finishing OSB siding products, consult the siding manufacturer.

Table 27 provides a summary of finishing recommendations for APA 303 Siding face grades. For complete information, refer to *APA Product Guide: Performance Rated Sidings, Form E300*.

### Semitransparent Stains (oil-based only)

Oil-based semitransparent stains emphasize grain patterns, texture and natural characteristics in the wood. They may be used on plywood face grades 303-OC, 303-NR and 303-6-W. It is the only finish recommended for use over brushed plywood. Other 303 face grades should not be finished with semitransparent stains unless specifically recommended by the panel manufacturer.

### Solid-Color Stains (oil or all-acrylic latex)

An opaque or solid-color stain obscures color differences in the wood and between repairs and surrounding wood. This is often a satisfactory finishing system, therefore, where semitransparent stains are unsuitable. Wood grain is also muted with solid-color stains but wood surface textures usually remain evident. When in question, the finish should be applied to a representative sample in order to demonstrate the finished appearance.

Solid-color stains are particularly recommended for grades 303-6-S and 303-6-S/W, as well as 303-18 and 303-30 with any type of patch.

TABLE 27

APA 303 SIDING FINISHING RECOMMENDATIONS

303 Series Plywood Siding Grades	STAINS		PAINTS
	Semitransparent (oil)	Solid Color (oil or latex) <sup>(a)</sup>	Minimum 1 primer plus 1 topcoat (acrylic latex)
303-OC	(b)	(b)	(b)
303-OL	Not Recommended	(d)	(b)
303-NR	(b)	(e)	(e)
303-SR	(c)	(e)	(e)
303-6-W	(b)	(b)	(b)
303-6-S	(c)	(b)	(b)
303-6-S/W	(c)	(b)	(b)
303-18-W	(c)	(b)	(b)
303-18-S	(c)	(b)	(b)
303-18-S/W	(c)	(b)	(b)
303-30-W	(c)	(b)	(b)
303-30-S	(c)	(b)	(b)
303-30-S/W	(c)	(b)	(b)

(a) Except for overlaid panels, use a stain-resistant primer with light-colored latex stains, since the wood extractives may cause a discoloration of the finish.

(b) Recommended with provisions given in text.

(c) Should not be finished with semitransparent stain unless specifically recommended by the panel manufacturer.

(d) Some panel manufacturers recommend only acrylic latex formulations. Consult the manufacturer's recommendations.

(e) Only acrylic latex formulations are recommended when solid-color stains or paint systems are applied over open voids.

### Paints (all-acrylic latex)

Top-quality acrylic latex house paint systems are recommended for all APA Rated Siding, except brushed plywood. If house paint is used on plywood siding, an all-acrylic latex paint system consisting of at least one stain-blocking prime coat and an all-acrylic latex topcoat is recommended. For extractive staining woods, some house paint systems utilize an oil-alkyd primer. Others use up to two coats of a stain-blocking acrylic latex primer. These latter systems help to reduce face-checking and generally offer superior performance. A paint finish tends to mask the textured plywood surface more than either semitransparent or solid-color stains. On the other hand, a top-quality acrylic latex paint system provides the most durable finish.

Grade 303-OL may be finished with any top-quality exterior paint system – primer and companion topcoat – formulated for wood.

### Field Application of Finish

Proper surface preparation is important for good performance of finishes on any surface. Remove dirt and loose wood fibers with a stiff nonmetallic bristle brush. Mildew may be removed with a solution of 1/4 part household bleach to 3/4 part warm water. Be sure to rinse thoroughly after application of bleach.

Finishes should be applied as soon as possible after installation of the siding. Weathering of unprotected wood can cause surface damage in as little as two to four weeks. Apply finishes during favorable weather conditions. As a rule of thumb, finishes should not be applied when the outside air temperature is expected to drop below 50° F (10° C) within 24 hours for latex finishes, or 40° F (5° C) for oil-based finishes. However, recommendations of individual manufacturers may vary and should always be followed. Wood surfaces should be clean and dry, although extremely dry surfaces should be dampened slightly when applying latex finishes.

Use only top-quality finishes and application equipment. Finishes should be applied according to the spread rates recommended by the manufacturer. Textured surfaces may require up to twice as much finish as smooth surfaces. The first coat should be applied by brush. If spray equipment is used to apply the finish, then the finish should be either back-brushed or back-rolled while it is still wet. Subsequent coats of finish may be applied by any conventional means.

### Interior Paneling

APA Rated Siding panels lend themselves to a number of decorative surface treatments for attractive interior paneling and accent walls. (See Figures 18 and 19.) Such treatments include saw-textured, brushed, embossed and grooved. Let APA panels acclimatize to room temperature and humidity conditions for several days prior to attachment to the wall. This can be accomplished by placing the panels on edge with space between each panel to allow air to circulate freely over both sides. Preservative treatment of furring or studs is recommended when they are attached to masonry or concrete exterior walls and to any uncured concrete wall. Also, in these instances, install a 4-mil polyethylene vapor retarder between the paneling and the furring or studs and insulated exterior walls. Support and nail spacing recommendations are given in Table 28. Recommendations apply to all species groups.

TABLE 28

**INTERIOR PANELING**

Panel Performance Category	Maximum Support Spacing (in.)	Nail Size (Use casing or finishing nails) <sup>(c)</sup>	Maximum Nail Spacing (in.)	
			Panel Edges	Intermediate Supports
1/4	16 <sup>(a)</sup>	4d	6	12
5/16	16 <sup>(b)</sup>	6d	6	12
11/32 - 1/2	24	6d	6	12
19/32 - 3/4	24	8d	6	12
Texture 1-11	24	8d	6	12

(a) Can be 20 inches if strength axis of paneling is across supports.

(c) See Table 5, page 14, for nail dimensions.

(b) Can be 24 inches if strength axis of paneling is across supports.



FIGURE 18

**PANELING NEW INTERIOR WALLS**

FIGURE 19

**PANELING EXISTING INTERIOR WALLS****Panel Backing**

Wood structural panels are excellent backing for wall coverings such as rare hardwoods, vinyl surfaces and decorative fabrics. Panels with Performance Categories smaller than 15/32 should be applied with strength axis perpendicular to studs and with 2x4 blocking at horizontal edges. Thicker panels may be applied with strength axis parallel to studs. For thin coverings subject to telegraphing of underlying surface texture, only sanded plywood is recommended. Plywood panels should have C-Plugged or better faces. Use 6d nails spaced 6 inches on center at panel edges and 12 inches on center at intermediate supports. A 1/16-inch space should be left between panels. Where moisture may be present, use nonstaining nails and either Exposure 1 or Exterior type panels. A 1/4-inch clearance is recommended at the bottom edge of the panels.

**Wood Structural Panel Wall Bracing and Shear Walls**

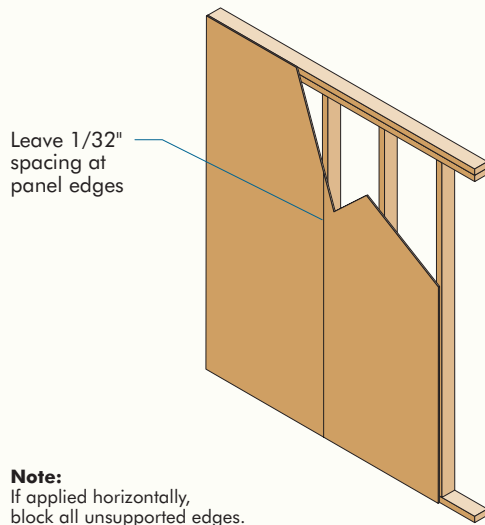
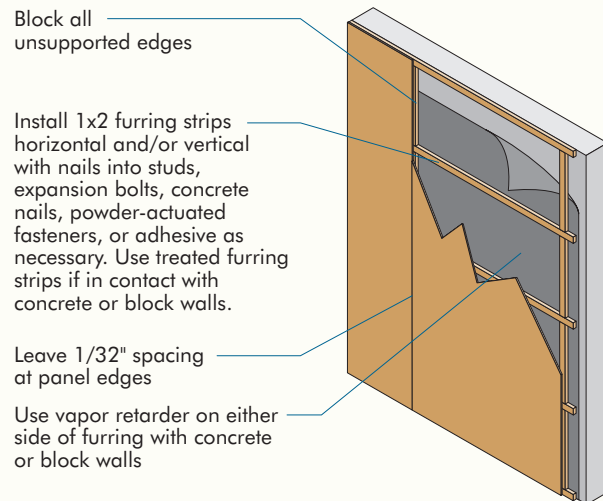
Wood structural panel wall bracing and shear walls are used to resist racking forces caused by lateral loads from wind or seismic events. Wall bracing and shear walls serve the same purpose, to resist wall-racking forces, but they have distinct differences as explained on [page 60](#). While all of the wall systems presented here will provide sufficient wall bracing strength under normal conditions in residential and light-frame construction, engineered shear walls may be desirable or required in areas of the country with frequent seismic activity or high wind loads. Shear walls are also integral to commercial and industrial construction.

**TABLE 29**  
**ALLOWABLE SHEAR (POUNDS PER FOOT) FOR APA PANEL SHEAR WALLS WITH FRAMING OF DOUGLAS-FIR, LARCH, OR SOUTHERN PINE<sup>(a)</sup> FOR WIND<sup>(b)(c)(d)(e)(f)</sup> OR SEISMIC<sup>(c)(d)(e)(g)</sup> LOADING**

Panel Grade	Minimum Nominal Panel Thickness (in.)	Minimum Nail Penetration in Framing (in.)	Panels Applied Direct to Framing				Panels Applied Over 1/2" or 5/8" Gypsum Sheathing						
			Nail Size (common or galvanized box) <sup>(h)</sup>	Nail Spacing at Panel Edges (in.)				Nail Size (common or galvanized box)	Nail Spacing at Panel Edges (in.)				
				6	4	3	2 <sup>(i)</sup>		6	4	3	2 <sup>(i)</sup>	
APA STRUCTURAL I grades	3/8			230 <sup>(i)</sup>	360 <sup>(i)</sup>	460 <sup>(i)</sup>	610 <sup>(i)</sup>						
	7/16	1-3/8	8d	255 <sup>(i)</sup>	395 <sup>(i)</sup>	505 <sup>(i)</sup>	670 <sup>(i)</sup>	10d	280	430	550 <sup>(i)</sup>	730	
	15/32			280	430	550	730						
APA RATED SHEATHING; APA RATED SIDING <sup>(m)</sup> and other APA grades except species Group 5	15/32	1-1/2	10d	340	510	665 <sup>(i)</sup>	870		—	—	—	—	
	5/16 or 1/4 <sup>(k)</sup>			180	270	350	450	8d	180	270	350	450	
	3/8	1-1/4	6d	200	300	390	510		200	300	390	510	
	3/8			220 <sup>(i)</sup>	320 <sup>(i)</sup>	410 <sup>(i)</sup>	530 <sup>(i)</sup>	10d					
	7/16	1-3/8	8d	240 <sup>(i)</sup>	350 <sup>(i)</sup>	450 <sup>(i)</sup>	585 <sup>(i)</sup>		260	380	490 <sup>(i)</sup>	640	
	15/32			260	380	490	640						
15/32			310	460	600 <sup>(i)</sup>	770	—	—	—	—	—		
19/32	1-1/2	10d	340	510	665 <sup>(i)</sup>	870	—	—	—	—	—		
APA RATED SIDING <sup>(m)</sup> and other APA grades except species Group 5	5/16 <sup>(k)</sup>	1-1/4	Nail Size (galvanized casing) 6d	140	210	275	360	Nail Size (galvanized casing) 8d	140	210	275	360	
	3/8	1-3/8	8d	160	240	310	410	10d	160	240	310 <sup>(i)</sup>	410	

- (a) For framing of other species: (1) Find specific gravity for species of lumber in the AF&PA National Design Specification (NDS). (2) For common or galvanized box nails, find shear value from table above for nail size for actual grade. (3) Multiply value by the following adjustment factor: Specific Gravity Adjustment Factor = [1 - (0.5 - SG)], where SG = specific gravity of the framing. This adjustment shall not be greater than 1.
- (b) For wind load applications, the values in the table above shall be permitted to be multiplied by 1.4.
- (c) All panel edges backed with 2-inch nominal or wider framing. Install panels either horizontally or vertically. Space nails maximum 6 inches o.c. along intermediate framing members for 3/8-inch and 7/16-inch panels installed on studs spaced 24 inches o.c. For other conditions and panel thicknesses, space nails maximum 12 inches o.c. on intermediate supports. Fasteners shall be located 3/8 inch from panel edges.
- (d) Where panels applied on both faces of a wall and nail spacing is less than 6 inches o.c. on either side, panel joints shall be offset to fall on different framing members, or framing shall be 3-inch nominal or thicker at adjoining panel edges and nails on each side shall be staggered.
- (e) Galvanized nails shall be hot-dip or tumbled.
- (f) For shear loads of normal or permanent load duration as defined by the AF&PA NDS, the values in the table above shall be multiplied by 0.63 or 0.56 respectively.
- (g) In Seismic Design Category D, E, or F, where shear design values exceed 350 pounds per lineal foot, all framing members receiving edge nailing from abutting panel edges shall not be less than a single 3-inch nominal member, or two 2-inch nominal members fastened together to transfer the design shear value between framing members. Wood structural panel joint and sill plate nailing shall be staggered in all cases. See IBC or AF&PA Special Design Provisions for Wind and Seismic (SDPWS) for sill plate size and anchorage requirements.
- (h) See Table 5, page 14, for nail dimensions.
- (i) Framing at adjoining panel edges shall be 3-inch nominal or wider, and nails shall be staggered where nails are spaced 2 inches o.c. Check local code for variations of these requirements.
- (j) Allowable shear values are permitted to be increased to values shown for 15/32-inch sheathing with same nailing provided (1) studs are spaced a maximum of 16 inches on center, or (2) panels are applied with long dimension across studs.
- (k) 3/8-inch or APA RATED SIDING 16 oc is minimum recommended when applied direct to framing as exterior siding.
- (l) Framing at adjoining panel edges shall be 3-inch nominal or wider, and nails shall be staggered where 10d nails (3" x 0.148") having penetration into framing of more than 1-1/2 inches are spaced 3 inches o.c. Check local code for variations of these requirements.
- (m) Values apply to all-veneer plywood APA RATED SIDING panels only. Other APA RATED SIDING panels may also qualify on a proprietary basis. APA RATED SIDING 16 oc plywood may be 11/32 inch, 3/8 inch or thicker. Thickness at point of nailing on panel edges governs shear values.

**Typical Layout for Shear Walls**

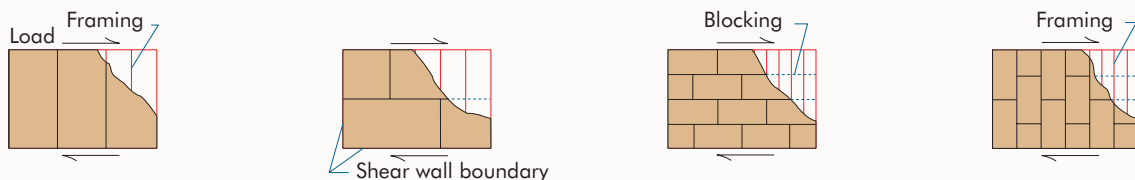

## Wall Bracing

Wall bracing is typically a part of conventional prescriptive construction as found in [2009 International Building Code \(IBC\) Section 2308](#) or the [International Residential Code \(IRC\) Chapter 6](#). Wall bracing is prescribed in a how-to format, and braced walls generally do not require hold down devices or have significant nailing requirements. Usually, there is no engineering required when using wall bracing since the “solution” is prescribed. For structures or portions of them that do not meet the prescribed construction parameters in the IBC or IRC, engineered design is required.

Meeting the bracing requirements is easy when using wood structural panel wall sheathing because of its inherent strength. More information is available at [www.wallbracing.org](http://www.wallbracing.org) and in the following APA publications:

- [Introduction to Wall Bracing, Form F430](#)
- [Brace Walls with Wood, Form G440](#)

## Shear Walls

The engineered version of wall bracing is a shear wall. Shear walls are designed by an engineer to resist the specific forces determined by engineering analysis. Shear walls have specific design values depending on their construction, fastener spacing, fastener size, sheathing thickness and framing species. [Table 29](#) shows the Allowable Stress Design values for single-sided sheathed wood structural panel shear walls. Shear walls are also permitted to be designed to account for openings and with both sides of the wall sheathed. They usually require hold downs to resist overturning of wall segments, as shown in Figure 20. More information on designing with shear walls is available in the APA publication [Design/Construction Guide: Diaphragms and Shear Walls, Form L350](#).

Either APA RATED SHEATHING or all-veneer plywood APA RATED SIDING (and other APA RATED SIDING panels that qualify on a proprietary basis) can be used in shear wall design. The data presented here give maximum shears for walls with APA RATED SHEATHING, with plywood APA RATED SIDING installed directly to studs (APA Sturd-I-Wall), and with panels applied over gypsum sheathing for walls required to be fire-rated from the outside.

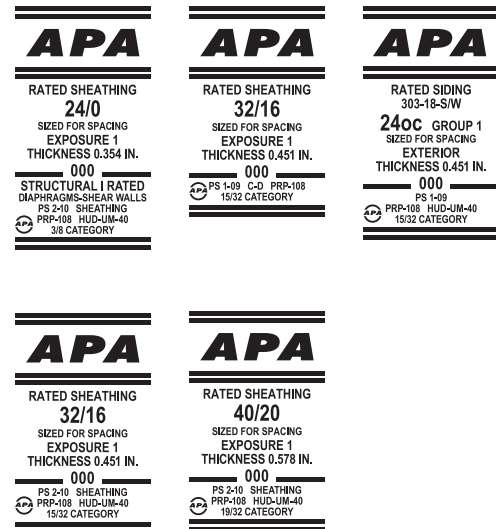
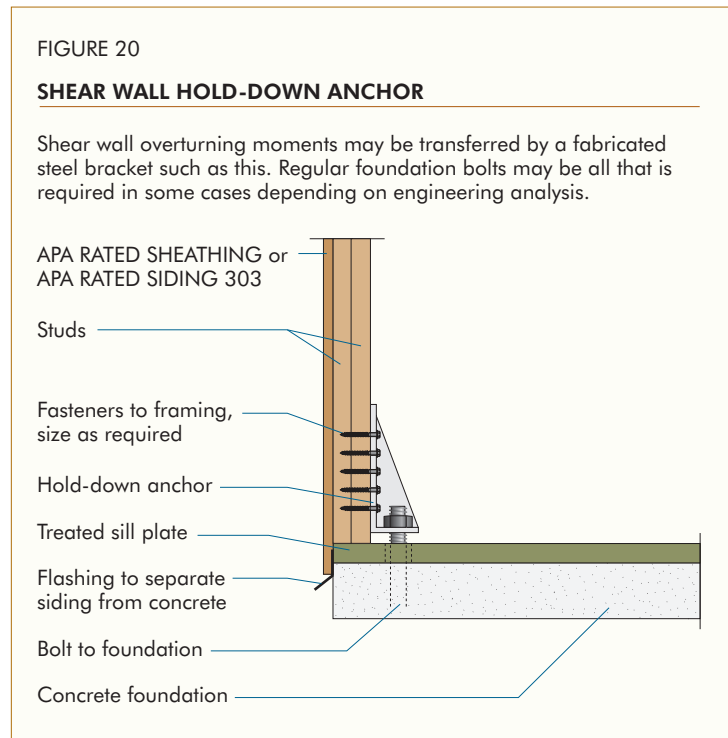

## ADDITIONAL INFORMATION

### About APA – The Engineered Wood Association



APA – *The Engineered Wood Association* is a nonprofit trade association of and for structural wood panel, glulam timber, wood I-joist, structural composite lumber, and other engineered wood product manufacturers. Based in Tacoma, Washington, APA represents approximately 150 mills throughout North America, ranging from small, independently owned and operated companies to large integrated corporations.

Always insist on engineered wood products bearing the **mark of quality** – the APA or APA EWS trademark. Your APA engineered wood purchase is not only your highest possible assurance of product quality, but an investment in the many trade services that APA provides on your behalf. The Association's trademark appears only on products manufactured by member mills and is the manufacturer's assurance that the product conforms to the standard shown on the trademark.

For panels, that standard may be the Voluntary Product Standard PS 1-09 for Structural Plywood, Voluntary Product Standard PS 2-10, Performance Standards for Wood-Based Structural-Use Panels or APA PRP-108 Performance Standards and Qualification Policy for Structural-Use Panels. Panel quality of all APA trademarked products is subject to verification through APA audit.

The APA or APA EWS trademark appears only on engineered wood products manufactured by members of APA. The mark signifies that the manufacturer is committed to a rigorous program of quality verification and testing and that products are manufactured in conformance with an APA or national standard such as ANSI/AITC A190.1, Standard for Structural Glued Laminated Timber; ANSI/APA PRP 210, Standard for Performance-Rated Engineered Wood Panel Siding; APA PRI-400, Performance Standard for APA EWS I-Joists; ANSI/APA PRR 410, Standard for Performance-Rated Engineered Wood Rim Boards; or with a manufacturer's building code evaluation report or APA Product Report ([www.apawood.org/ProductReports](http://www.apawood.org/ProductReports)).

APA's services go far beyond quality testing and inspection. Research and promotion programs play important roles in developing and improving construction systems using wood structural panels, glulam, I-joists, and structural composite lumber, and in helping users and specifiers to better understand and apply engineered wood products. For more information, please see the back cover.



# Engineered Wood Construction Guide

APA offers a comprehensive set of services and tools for design and construction professionals specifying and using engineered wood products and building systems. If you're looking for detailed product information, training material, or technical assistance, APA can help.

- ▶▶▶▶ [www.apawood.org](http://www.apawood.org), APA's website, is your link to in-depth design and building support, including a library of more than 400 publications available for instant pdf download or hard-copy purchase.
- ▶▶▶▶ [help@apawood.org](mailto:help@apawood.org) or (253) 620-7400 is your connection to the APA Product Support Help Desk. Staffed by specialists who have the knowledge to address a diverse range of inquiries related to engineered wood, the Help Desk can answer your questions about specification and application of APA products.

## Tap into APA's extensive knowledge and resources.

- Training materials and assistance, including Wood University, APA's online portal for engineered wood education, located at [www.wooduniversity.org](http://www.wooduniversity.org)
- Information to protect homes against damaging moisture infiltration through the Build a Better Home and Free From Mold programs, including guides and details for builders at [www.buildabetterhome.org](http://www.buildabetterhome.org) and an inspection regimen for homeowners at [www.freefrommold.org](http://www.freefrommold.org)
- More than 200 downloadable CAD details, found at [www.apacad.org](http://www.apacad.org)
- Field representatives in many major U.S. cities and Canada who can answer questions about APA trademarked products

For a list of APA and APA EWS publications, download the *APA Publications Index*, Form B300, at [www.apawood.org/publications](http://www.apawood.org/publications).

## APA – THE ENGINEERED WOOD ASSOCIATION HEADQUARTERS

7011 So. 19th St. Tacoma, Washington 98466 ■ (253) 565-6600 ■ Fax: (253) 565-7265

### DISCLAIMER

*The information contained herein is based on APA – The Engineered Wood Association's continuing programs of laboratory testing, product research, and comprehensive field experience. Neither APA, nor its members make any warranty, expressed or implied, or assume any legal liability or responsibility for the use, application of, and/or reference to opinions, findings, conclusions, or recommendations included in this publication. Consult your local jurisdiction or design professional to assure compliance with code, construction, and performance requirements. Because APA has no control over quality of workmanship or the conditions under which engineered wood products are used, it cannot accept responsibility of product performance or designs as actually constructed.*



[www.apawood.org](http://www.apawood.org)



Form No. E30V/Revised August 2011/1200

