

HAMPTON

DESIGNER COLLECTION

H | S

PVC SYSTEMS INCLUDE:

- 8 Fully directional adjustable PVC jets
- Anti-vortex safety suction
- Color matched system trim
- HydroOzone ozone sanitation system
- Rigid PVC piping
- Self draining pump and system
- Soft Touch electronic on/off control with 30-minute integral times
- 2.25 HP single speed pump
- Cable waste and overflow
- Requires 20 Amp Dedicated GFCI



The Hampton is the perfect design solution for those that want the spaciousness of an oversized bathtub and the comfort of a bathtub designed for a single bather. Visit <http://www.hydrosystem.com> for more details on our options and accessories.

HAMPTON

DESIGNER COLLECTION

H | S

As SHOWN:

Whirlpool option with standard jets

FEATURES SHOWN:

- Jets
- Anti-vortex suction
- Overflow location

ALSO AVAILABLE:

- Soaking tub only
- Whirlpool
- Thermal Air
- Combo

SIZE:

72.42.20

WATER CAPACITY:

85 Gallons

MODEL 7243 DIMENSIONS:

- (L)ength- 72"
- (W)idth- 42"
- (H)eight Finish- 20"



ACRYLIC TUB

- Acrylic models finished in 1/8" thick layer of deep lustrous acrylic
- Extra thick reinforced fiberglass
- Pre-wired pump on pump platform (standard pump location only)
- Integral E-Z level platform facilitates installation
- Non-skid bottom

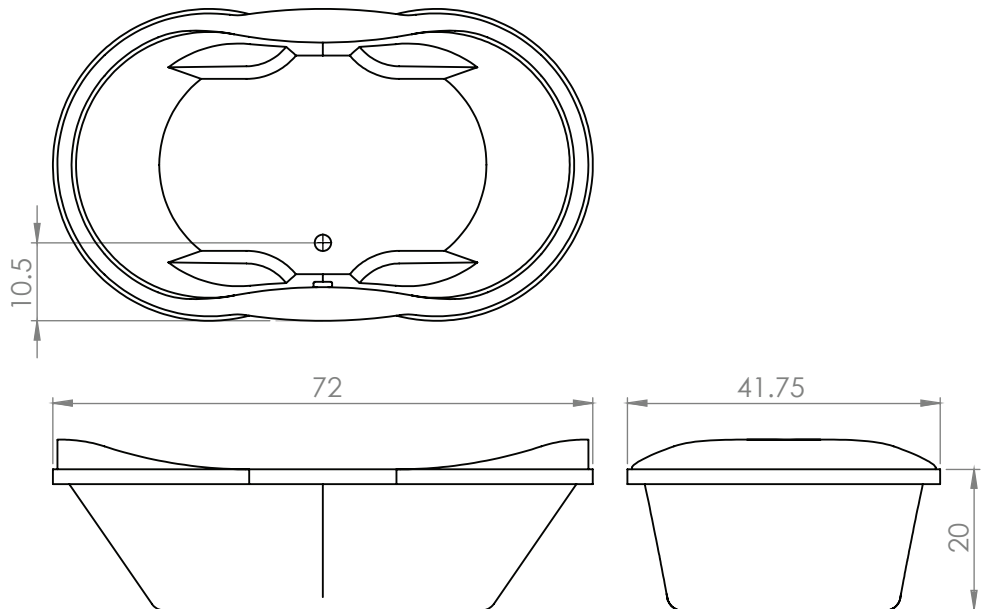

CODES AND COMPLIANCES

Massachusetts code File no: P1-0614-491



HYDRO SYSTEMS
Family Owned And Operated Since 1978

29132 Avenue Paine, Valencia, CA, 91355
661.775.0686 | hydrosystem.com

All specifications and options subject to change without notice please contact a Hydro Systems representative for more information. Certain options or altering the pump/blower location may cause the pump/blower to extend beyond the tub decking. For cutout dimensions wait for unit to arrive. All specifications subject to change without notice.