

# OPERATOR'S MANUAL

## 12 in. COMPOUND MITER SAW WITH LASER

R4120 - Double Insulated

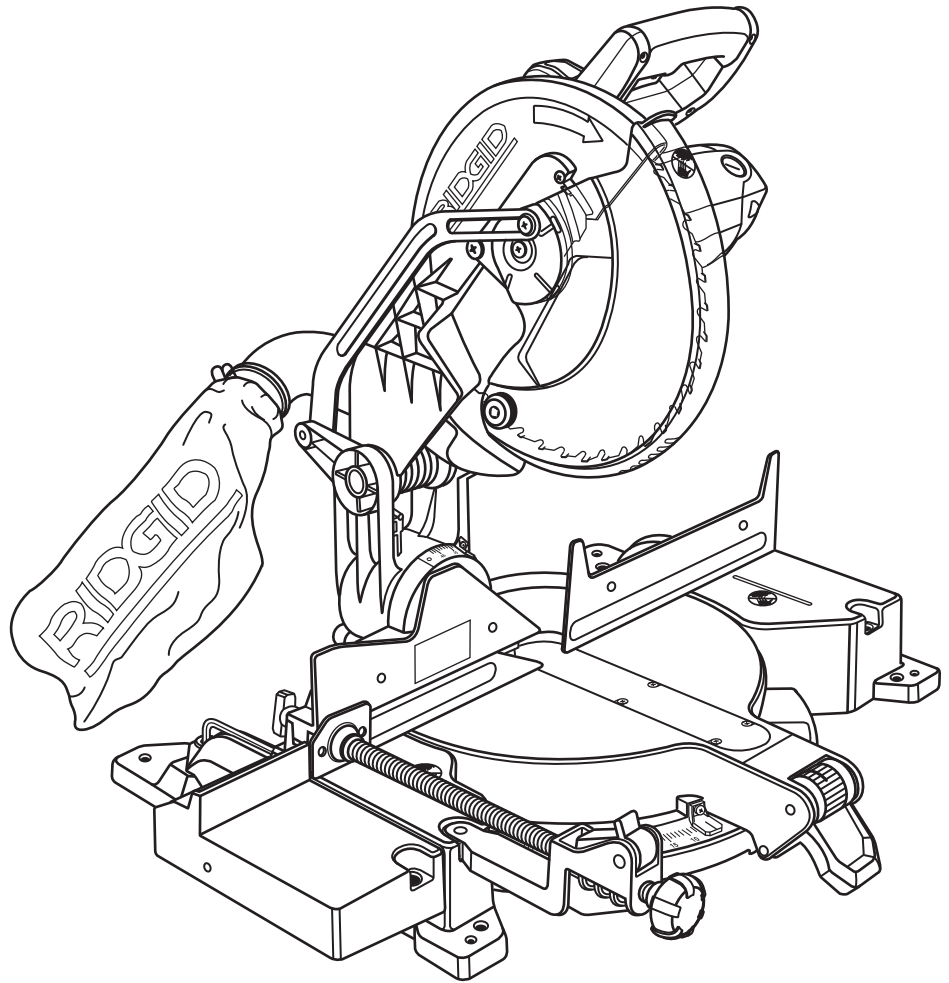

Your miter saw has been engineered and manufactured to our high standard for dependability, ease of operation, and operator safety. When properly cared for, it will give you years of rugged, trouble-free performance.

**⚠ WARNING:**

To reduce the risk of injury, the user must read and understand the operator's manual before using this product.

Thank you for buying a RIDGID® product.

**SAVE THIS MANUAL FOR FUTURE REFERENCE**

# TABLE OF CONTENTS

---

■ Introduction.....	2
■ General Safety Rules .....	3-4
■ Specific Safety Rules.....	4-5
■ Symbols.....	6-7
■ Electrical .....	8
■ Glossary of Terms .....	9
■ Features .....	10-12
■ Tools Needed .....	13
■ Loose Parts.....	13
■ Assembly .....	14-22
■ Operation .....	23-31
■ Adjustments.....	32
■ Maintenance .....	33-34
■ Warranty .....	35
■ Parts Ordering/Service .....	36

## INTRODUCTION

---

This tool has many features for making its use more pleasant and enjoyable. Safety, performance, and dependability have been given top priority in the design of this product making it easy to maintain and operate.

# GENERAL SAFETY RULES

---

## **WARNING:**

**Read and understand all instructions.** Failure to follow all instructions listed below, may result in electric shock, fire and/or serious personal injury.

---

## **READ ALL INSTRUCTIONS**

- **KNOW YOUR POWER TOOL.** Read the operator's manual carefully. Learn the applications and limitations as well as the specific potential hazards related to this tool.
- **GUARD AGAINST ELECTRICAL SHOCK BY PREVENTING BODY CONTACT WITH GROUNDED SURFACES.** For example: pipes, radiators, ranges, refrigerator enclosures.
- **KEEP GUARDS IN PLACE** and in good working order.
- **REMOVE ADJUSTING KEYS AND WRENCHES.** Form habit of checking to see that keys and adjusting wrenches are removed from tool before turning it on.
- **KEEP WORK AREA CLEAN.** Cluttered areas and benches invite accidents. **DO NOT** leave tools or pieces of wood on the tool while it is in operation.
- **DO NOT USE IN DANGEROUS ENVIRONMENTS.** Do not use power tools in damp or wet locations or expose to rain. Keep the work area well lit.
- **KEEP CHILDREN AND VISITORS AWAY.** All visitors should wear safety glasses and be kept a safe distance from work area. Do not let visitors contact tool or extension cord while operating.
- **MAKE WORKSHOP CHILDPROOF** with padlocks, master switches, or by removing starter keys.
- **DON'T FORCE THE TOOL.** It will do the job better and safer at the feed rate for which it was designed.
- **USE THE RIGHT TOOL.** Do not force the tool or attachment to do a job for which it was not designed.
- **USE THE PROPER EXTENSION CORD.** Make sure your extension cord is in good condition. Use only a cord heavy enough to carry the current your product will draw. An undersized cord will cause a drop in line voltage resulting in loss of power and overheating. A wire gauge size (A.W.G.) of at least **14** is recommended for an extension cord 25 feet or less in length. If in doubt, use the next heavier gauge. The smaller the gauge number, the heavier the cord.
- **DRESS PROPERLY.** Do not wear loose clothing, neckties, or jewelry that can get caught and draw you into moving parts. Rubber gloves and nonskid footwear are recommended when working outdoors. Also wear protective hair covering to contain long hair.
- **ALWAYS WEAR SAFETY GLASSES WITH SIDE SHIELDS.** Everyday eyeglasses have only impact-resistant lenses, they are **NOT** safety glasses.
- **SECURE WORK.** Use clamps or a vise to hold work when practical, it is safer than using your hand and frees both hands to operate the tool.
- **DO NOT OVERREACH.** Keep proper footing and balance at all times.
- **MAINTAIN TOOLS WITH CARE.** Keep tools sharp and clean for better and safer performance. Follow instructions for lubricating and changing accessories.
- **DISCONNECT TOOLS.** When not in use, before servicing, or when changing attachments, blades, bits, cutters, etc., all tools should be disconnected from power source.
- **AVOID ACCIDENTAL STARTING.** Be sure switch is off when plugging in any tool.
- **USE RECOMMENDED ACCESSORIES.** Consult the operator's manual for recommended accessories. The use of improper accessories may result in injury.
- **NEVER STAND ON TOOL.** Serious injury could occur if the tool is tipped or if the cutting tool is unintentionally contacted.
- **CHECK DAMAGED PARTS.** Before further use of the tool, a guard or other part that is damaged should be carefully checked to determine that it will operate properly and perform its intended function. Check for alignment of moving parts, binding of moving parts, breakage of parts, mounting and any other conditions that may affect its operation. A guard or other part that is damaged must be properly repaired or replaced by an authorized service center to avoid risk of personal injury.
- **USE THE RIGHT DIRECTION OF FEED.** Feed work into a blade, cutter, or sanding spindle against the direction or rotation of the blade, cutter, or sanding spindle only.
- **NEVER LEAVE TOOL RUNNING UNATTENDED. TURN THE POWER OFF.** Don't leave tool until it comes to a complete stop.
- **PROTECT YOUR LUNGS.** Wear a face or dust mask if the cutting operation is dusty.
- **PROTECT YOUR HEARING.** Wear hearing protection during extended periods of operation.
- **DO NOT ABUSE CORD.** Never carry tool by the cord or yank it to disconnect from receptacle. Keep cord from heat, oil, and sharp edges.
- **USE OUTDOOR EXTENSION CORDS.** When tool is used outdoors, use only extension cords with approved ground connection that are intended for use outdoors and so marked.
- **KEEP BLADES CLEAN, SHARP, AND WITH SUFFICIENT SET.** Sharp blades minimize stalling and kickback.
- **BLADE COASTS AFTER BEING TURNED OFF.**

# GENERAL SAFETY RULES

---

- **NEVER USE IN AN EXPLOSIVE ATMOSPHERE.** Normal sparking of the motor could ignite fumes.
- **INSPECT TOOL CORDS PERIODICALLY.** If damaged, have repaired by a qualified service technician at an authorized service facility. The conductor with insulation having an outer surface that is green with or without yellow stripes is the equipment-grounding conductor. If repair or replacement of the electric cord or plug is necessary, do not connect the equipment-grounding conductor to a live terminal. Repair or replace a damaged or worn cord immediately. Stay constantly aware of cord location and keep it well away from the rotating blade.
- **INSPECT EXTENSION CORDS PERIODICALLY** and replace if damaged.
- **POLARIZED PLUGS.** To reduce the risk of electric shock, this tool has a polarized plug (one blade is wider than the other). This plug will fit in a polarized outlet only one way. If the plug does not fit fully in the outlet, reverse the plug. If it still does not fit, contact a qualified electrician to install the proper outlet. Do not change the plug in any way.
- **KEEP TOOL DRY, CLEAN, AND FREE FROM OIL AND GREASE.** Always use a clean cloth when cleaning. Never use brake fluids, gasoline, petroleum-based products, or any solvents to clean tool.
- **STAY ALERT AND EXERCISE CONTROL.** Watch what you are doing and use common sense. Do not operate tool when you are tired. Do not rush.
- **DO NOT USE TOOL IF SWITCH DOES NOT TURN IT ON AND OFF.** Have defective switches replaced by an authorized service center.
- **USE ONLY CORRECT BLADES.** Do not use blades with incorrect size holes. Never use blade washers or blade bolts that are defective or incorrect. The maximum blade capacity of your saw is 12 in.
- **BEFORE MAKING A CUT, BE SURE ALL ADJUSTMENTS ARE SECURE.**
- **BE SURE BLADE PATH IS FREE OF NAILS.** Inspect for and remove all nails from lumber before cutting.
- **NEVER TOUCH BLADE** or other moving parts during use.
- **NEVER START A TOOL WHEN ANY ROTATING COMPONENT IS IN CONTACT WITH THE WORKPIECE.**
- **DO NOT OPERATE A TOOL WHILE UNDER THE INFLUENCE OF DRUGS, ALCOHOL, OR ANY MEDICATION.**
- **WHEN SERVICING** use only identical replacement parts. Use of any other parts may create a hazard or cause product damage.
- **USE ONLY RECOMMENDED ACCESSORIES** listed in this manual or addendums. Use of accessories that are not listed may cause the risk of personal injury. Instructions for safe use of accessories are included with the accessory.
- **DOUBLE CHECK ALL SETUPS.** Make sure blade is tight and not making contact with saw or workpiece before connecting to power supply.

# SPECIFIC SAFETY RULES

---

- **FIRMLY CLAMP OR BOLT** your tool to a workbench or table at approximately hip height.
- **KEEP HANDS AWAY FROM CUTTING AREA.** Do not reach underneath work or in blade cutting path with your hands and fingers for any reason. Always turn the power off.
- **ALWAYS SUPPORT LONG WORKPIECES** while cutting to minimize risk of blade pinching and kickback. Saw may slip, walk or slide while cutting long or heavy boards.
- **ALWAYS USE A CLAMP** to secure the workpiece when possible.
- **BE SURE THE BLADE CLEARS THE WORKPIECE.** Never start the saw with the blade touching the workpiece. Allow motor to come up to full speed before starting cut.
- **MAKE SURE THE MITER TABLE AND SAW ARM (BEVEL FUNCTION) ARE LOCKED IN POSITION BEFORE OPERATING YOUR SAW.** Lock the miter table by securely tightening the miter lock levers. Lock the saw arm (bevel function) by securely tightening the bevel lock knob.
- **NEVER USE A LENGTH STOP ON THE FREE SCRAP END OF A CLAMPED WORKPIECE. NEVER** hold onto or bind the free scrap end of the workpiece in any operation. If a work clamp and length stop are used together, they must both be installed on the same side of the saw table to prevent the saw from catching the loose end and kicking up.
- **NEVER** cut more than one piece at a time. **DO NOT STACK** more than one workpiece on the saw table at a time.
- **NEVER PERFORM ANY OPERATION FREEHAND.** Always place the workpiece to be cut on the miter table and position it firmly against the fence as a backstop. Always use the fence.

# SPECIFIC SAFETY RULES

---

- **NEVER** hand hold a workpiece that is too small to be clamped. Keep hands clear of the cutting area.
- **NEVER** reach behind, under, or within three inches of the blade and its cutting path with your hands and fingers for any reason.
- **NEVER** reach to pick up a workpiece, a piece of scrap, or anything else that is in or near the cutting path of the blade.
- **AVOID AWKWARD OPERATIONS AND HAND POSITIONS** where a sudden slip could cause your hand to move into the blade. **ALWAYS** make sure you have good balance. **NEVER** operate your miter saw on the floor or in a crouched position.
- **NEVER** stand or have any part of your body in line with the path of the saw blade.
- **ALWAYS** release the power switch and allow the saw blade to stop rotating before raising it out of the workpiece.
- **DO NOT TURN THE MOTOR SWITCH ON AND OFF RAPIDLY.** This could cause the saw blade to loosen and could create a hazard. Should this ever occur, stand clear and allow the saw blade to come to a complete stop. Disconnect your saw from the power supply and securely retighten the blade bolt.
- **IF ANY PART OF THIS MITER SAW IS MISSING** or should break, bend, or fail in any way, or should any electrical component fail to perform properly, shut off the power switch, remove the miter saw plug from the power source and have damaged, missing, or failed parts replaced before resuming operation.
- **IF THE POWER SUPPLY CORD IS DAMAGED,** it must be replaced only by the manufacturer or by an authorized service center to avoid risk.
- **ALWAYS STAY ALERT!** Do not allow familiarity (gained from frequent use of your saw) to cause a careless mistake. **ALWAYS REMEMBER** that a careless fraction of a second is sufficient to inflict severe injury.
- **MAKE SURE THE WORK AREA HAS AMPLE LIGHTING** to see the work and that no obstructions will interfere with safe operation **BEFORE** performing any work using your saw.
- **ALWAYS TURN OFF THE SAW** before disconnecting it to avoid accidental starting when reconnecting to power supply. **NEVER** leave the saw unattended while connected to a power source.
- **THIS TOOL** should have the following markings:
  - a) Wear eye protection.
  - b) Keep hands out of path of saw blade.
  - c) Do not operate saw without guards in place.
  - d) Do not perform any operation freehand.
  - e) Never reach around saw blade.
  - f) Turn off tool and wait for saw blade to stop before moving workpiece or changing settings.
  - g) Disconnect power (or unplug tool as applicable) before changing blade or servicing.
  - h) No load speed.
- **ALWAYS** carry the tool only by the carrying handle.
- **AVOID** direct eye exposure when using the laser guide.
- **THIS SAW CAN TIP OVER** if the saw head is released suddenly and the saw is not secured to a work surface. **ALWAYS** secure this saw to a stable work surface before any use to avoid serious personal injury.
- **USE THIS SAW TO CUT WOOD, WOOD PRODUCTS, AND SOME PLASTICS ONLY. DO NOT CUT METALS, CERAMICS OR MASONRY PRODUCTS.**
- **SAVE THESE INSTRUCTIONS.** Refer to them frequently and use to instruct other users. If you loan someone this tool, loan them these instructions also.

---

## **WARNING:**

Some dust created by power sanding, sawing, grinding, drilling, and other construction activities contains chemicals known to cause cancer, birth defects or other reproductive harm. Some examples of these chemicals are:







- lead from lead-based paints,
- crystalline silica from bricks and cement and other masonry products, and
- arsenic and chromium from chemically-treated lumber.

Your risk from these exposures varies, depending on how often you do this type of work. To reduce your exposure to these chemicals: work in a well ventilated area, and work with approved safety equipment, such as those dust masks that are specially designed to filter out microscopic particles.

---

# SYMBOLS



Some of the following symbols may be used on this tool. Please study them and learn their meaning. Proper interpretation of these symbols will allow you to operate the tool better and safer.

SYMBOL	NAME	DESIGNATION/EXPLANATION
V	Volts	Voltage
A	Amperes	Current
Hz	Hertz	Frequency (cycles per second)
W	Watt	Power
min	Minutes	Time
~	Alternating Current	Type of current
==	Direct Current	Type or a characteristic of current
$n_0$	No Load Speed	Rotational speed, at no load
	Class II Construction	Double-insulated construction
.../min	Per Minute	Revolutions, strokes, surface speed, orbits, etc., per minute
	Wet Conditions Alert	Do not expose to rain or use in damp locations.
	Read The Operator's Manual	To reduce the risk of injury, user must read and understand operator's manual before using this product.
	Eye Protection	Always wear safety goggles or safety glasses with side shields and, as necessary, a full face shield when operating this product.
	Safety Alert	Precautions that involve your safety.
	No Hands Symbol	Failure to keep your hands away from the blade will result in serious personal injury.
	Hot Surface	To reduce the risk of injury or damage, avoid contact with any hot surface.

# SYMBOLS

---

The following signal words and meanings are intended to explain the levels of risk associated with this product.

SYMBOL	SIGNAL	MEANING
	<b>DANGER:</b>	Indicates an imminently hazardous situation, which, if not avoided, will result in death or serious injury.
	<b>WARNING:</b>	Indicates a potentially hazardous situation, which, if not avoided, could result in death or serious injury.
	<b>CAUTION:</b>	Indicates a potentially hazardous situation, which, if not avoided, may result in minor or moderate injury.
	<b>CAUTION:</b>	(Without Safety Alert Symbol) Indicates a situation that may result in property damage.

## SERVICE

Servicing requires extreme care and knowledge and should be performed only by a qualified service technician. For service we suggest you return the product to your nearest **AUTHORIZED SERVICE CENTER** for repair. When servicing, use only identical replacement parts.

---

### **WARNING:**

To avoid serious personal injury, do not attempt to use this product until you read thoroughly and understand completely the operator's manual. Save this operator's manual and review frequently for continuing safe operation and instructing others who may use this product. Call RIDGID® customer service for assistance.

---

---

### **WARNING:**



The operation of any power tool can result in foreign objects being thrown into your eyes, which can result in severe eye damage. Before beginning power tool operation, always wear safety goggles or safety glasses with side shields and a full face shield when needed. We recommend Wide Vision Safety Mask for use over eyeglasses or standard safety glasses with side shields. Always use eye protection which is marked to comply with ANSI Z87.1.

---

## SAVE THESE INSTRUCTIONS



# ELECTRICAL

---

## DOUBLE INSULATION

Double insulation is a concept in safety in electric power tools, which eliminates the need for the usual three-wire grounded power cord. All exposed metal parts are isolated from the internal metal motor components with protecting insulation. Double insulated tools do not need to be grounded.

---

### **WARNING:**

The double insulated system is intended to protect the user from shock resulting from a break in the tool's internal wiring. Observe all normal safety precautions to avoid electrical shock.

---

**NOTE:** Servicing of a product with double insulation requires extreme care and knowledge of the system and should be performed only by a qualified service technician. For service, we suggest you return the tool to your nearest authorized service center for repair. Always use original factory replacement parts when servicing.

## ELECTRICAL CONNECTION

This tool has a precision-built electric motor. It should be connected to a **power supply that is 120 V, AC only (normal household current), 60 Hz**. Do not operate this tool on direct current (DC). A substantial voltage drop will cause a loss of power and the motor will overheat. If the tool does not operate when plugged into an outlet, double check the power supply.

## EXTENSION CORDS

When using a power tool at a considerable distance from a power source, be sure to use an extension cord that has the capacity to handle the current the product will draw. An undersized cord will cause a drop in line voltage, resulting in overheating and loss of power. Use the chart to determine the minimum wire size required in an extension cord. Only round jacketed cords listed by Underwriter's Laboratories (UL) should be used.

When working outdoors with a product, use an extension cord that is designed for outside use. This type of cord is designated with "WA" on the cord's jacket.

Before using any extension cord, inspect it for loose or exposed wires and cut or worn insulation.

---

\*\*Ampere rating (on product data plate)

Cord Length	Wire Size (A.W.G.)					
	0-2.0	2.1-3.4	3.5-5.0	5.1-7.0	7.1-12.0	12.1-16.0
25'	16	16	16	16	14	14
50'	16	16	16	14	14	12
100'	16	16	14	12	10	—

\*\*Used on 12 gauge - 20 amp circuit.

**NOTE:** AWG = American Wire Gauge

---

### **WARNING:**

Keep the extension cord clear of the working area. Position the cord so that it will not get caught on lumber, tools, or other obstructions while you are working with a power tool. Failure to do so can result in serious personal injury.

---

### **WARNING:**

Check extension cords before each use. If damaged replace immediately. Never use tool with a damaged cord since touching the damaged area could cause electrical shock resulting in serious injury.

---



# GLOSSARY OF TERMS

---

## **Anti-Kickback Pawls (radial arm and table saws)**

A device which, when properly installed and maintained, is designed to stop the workpiece from being kicked back toward the front of the saw during a ripping operation.

## **Arbor**

The shaft on which a blade or cutting tool is mounted.

## **Bevel Cut**

A cutting operation made with the blade at any angle other than 90° to the table surface.

## **Chamfer**

A cut removing a wedge from a block so the end (or part of the end) is angled rather than at 90°.

## **Compound Cut**

A cross cut made with both a miter and a bevel angle.

## **Cross Cut**

A cutting or shaping operation made across the grain or the width of the workpiece.

## **Cutter Head (planers and jointer planers)**

A rotating cutterhead with adjustable blades or knives. The blades or knives remove material from the workpiece.

## **Dado Cut**

A non-through cut which produces a square-sided notch or trough in the workpiece (requires a special blade).

## **Featherboard**

A device used to help control the workpiece by guiding it securely against the table or fence during any ripping operation.

## **FPM or SPM**

Feet per minute (or strokes per minute), used in reference to blade movement.

## **Freehand**

Performing a cut without the workpiece being guided by a fence, miter gauge, or other aids.

## **Gum**

A sticky, sap-based residue from wood products.

## **Heel**

Alignment of the blade to the fence.

## **Kerf**

The material removed by the blade in a through cut or the slot produced by the blade in a non-through or partial cut.

## **Kickback**

A hazard that can occur when the blade binds or stalls, throwing the workpiece back toward operator.

## **Leading End**

The end of the workpiece pushed into the tool first.

## **Miter Cut**

A cutting operation made with the workpiece at any angle to the blade other than 90°.

## **Non-Through Cuts**

Any cutting operation where the blade does not extend completely through the thickness of the workpiece.

## **Push Blocks (for jointer planers)**

Device used to feed the workpiece over the jointer planer cutterhead during any operation. This aid helps keep the operator's hands well away from the cutterhead.

## **Push Blocks and Push Sticks (for table saws)**

Devices used to feed the workpiece through the saw blade during cutting operations. A push stick (not a push block) should be used for narrow ripping operations. These aids help keep the operator's hands well away from the blade.

## **Pilot Hole (drill presses)**

A small hole drilled in a workpiece that serves as a guide for drilling large holes accurately.

## **Resaw**

A cutting operation to reduce the thickness of the workpiece to make thinner pieces.

## **Resin**

A sticky, sap-based substance that has hardened.

## **Revolutions Per Minute (RPM)**

The number of turns completed by a spinning object in one minute.

## **Ripping or Rip Cut**

A cutting operation along the length of the workpiece.

## **Riving Knife/Spreader/Splitter (table saws)**

A metal piece, slightly thinner than the blade, which helps keep the kerf open and also helps to prevent kickback.

## **Saw Blade Path**

The area over, under, behind, or in front of the blade. As it applies to the workpiece, that area which will be or has been cut by the blade.

## **Set**

The distance that the tip of the saw blade tooth is bent (or set) outward from the face of the blade.

## **Snipe (planers)**

Depression made at either end of a workpiece by cutter blades when the workpiece is not properly supported.

## **Through Sawing**

Any cutting operation where the blade extends completely through the thickness of the workpiece.

## **Throw-Back**

The throwing back of a workpiece usually caused by the workpiece being dropped into the blade or being placed inadvertently in contact with the blade.

## **Workpiece or Material**

The item on which the operation is being done.

## **Worktable**

Surface where the workpiece rests while performing a cutting, drilling, planing, or sanding operation.

# FEATURES

## PRODUCT SPECIFICATIONS

Blade Diameter..... 12 in.  
 Arbor Hole ..... 1 in.  
 No Load Speed ..... 4,000 r/min. (RPM)  
 Input ..... 120 V, AC Only, 60 Hz, 15 Amps  
 Cutting Capacity for Baseboards against the fence:  
 Maximum height ..... 6 in.

Cutting Capacity with Miter at 0°/Bevel 0°:  
 Maximum nominal lumber sizes:..... 2 x 8, 4 x 4  
 Cutting Capacity with Miter at 45°/Bevel 0°:  
 Maximum nominal lumber sizes:..... 2 x 6  
 Cutting Capacity with Miter at 0°/Bevel 45°:  
 Maximum nominal lumber sizes:..... 2 x 8  
 Cutting Capacity with Miter at 45°/Bevel 45°:  
 Maximum nominal lumber sizes:..... 2 x 6

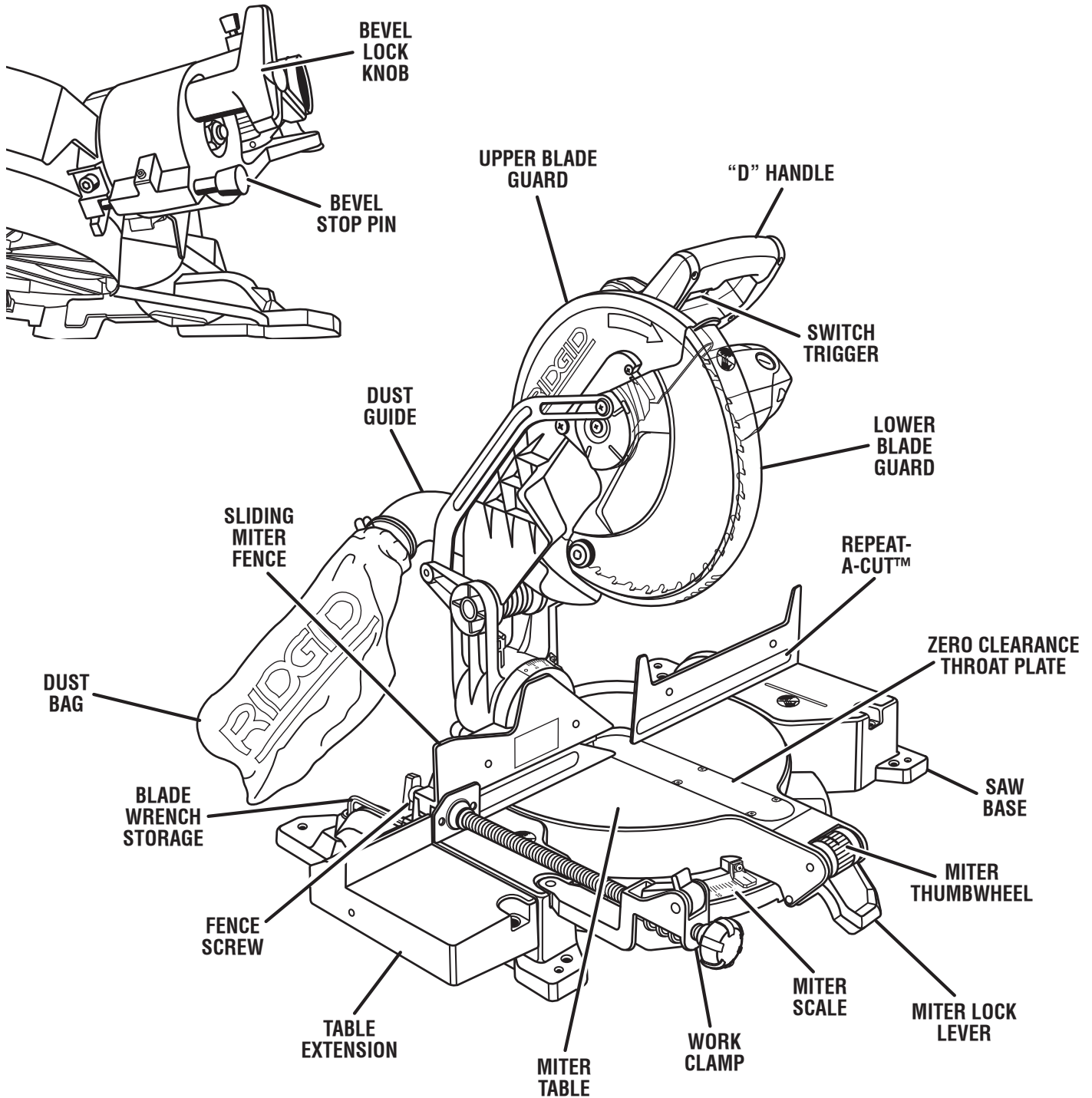

Fig. 1

# FEATURES

## KNOW YOUR COMPOUND MITER SAW

See Figure 1.

The safe use of this product requires an understanding of the information on the tool and in this operator's manual as well as a knowledge of the project you are attempting. Before use of this product, familiarize yourself with all operating features and safety rules.

### 12 in. BLADE

A 12 in. blade is included with your compound miter saw. It will cut materials up to 7-7/8 in. wide, depending upon the angle at which the cut is being made.

### 15 AMP MOTOR

This saw has a powerful 15 amp motor with sufficient power to handle tough cutting jobs. It is made with all ball bearings, and has externally accessible brushes for ease of servicing.

### BEVEL STOP ADJUSTMENT SCREWS

Bevel stop adjustment screws have been provided on each side of the saw arm. These adjustment screws are for making fine adjustments at 0° and 45°. The saw has additional bevel stops at 3° and 48°.

### BEVEL LOCK KNOB

The bevel lock knob securely locks your compound miter saw at desired bevel angles.

### BLADE WRENCH STORAGE

A blade wrench is packed with this saw. One end of the wrench is a phillips screwdriver and the other end is a hex key. Use the hex key end when installing or removing blade and the phillips end when removing or loosening screws. A storage area for the blade wrench is located in the saw's base.

### CARRYING HANDLE

See Figure 2.

For convenience when carrying or transporting the miter saw from one place to another, a carrying handle has been provided on top of the saw arm. To transport, turn off and unplug the saw, then lower the saw arm and lock it in the down position. Lock saw arm by depressing the lock pin.

### ELECTRIC BRAKE

An electric brake has been provided to quickly stop blade rotation after the switch is released.

### LASER GUIDE

For more accurate cuts, a laser guide is included with your miter saw. When used properly, the laser guide makes accurate, precision cutting simple and easy.

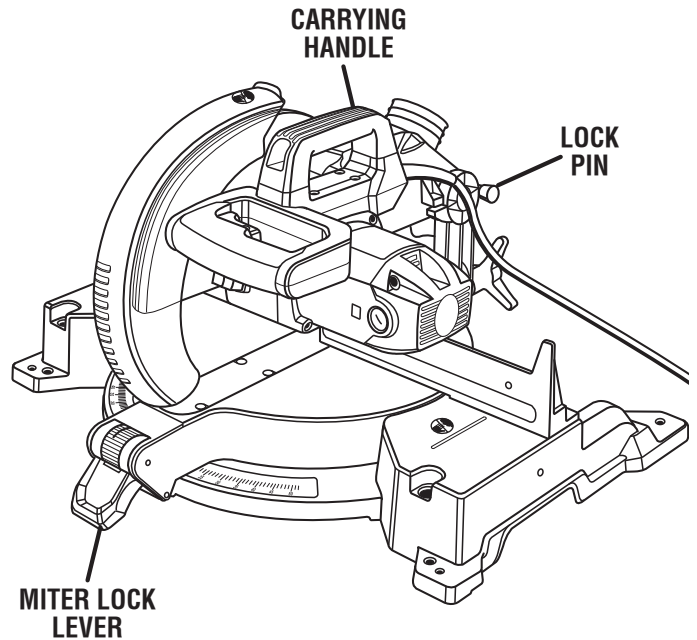

SAW ARM LOCKED IN DOWN POSITION

Fig. 2

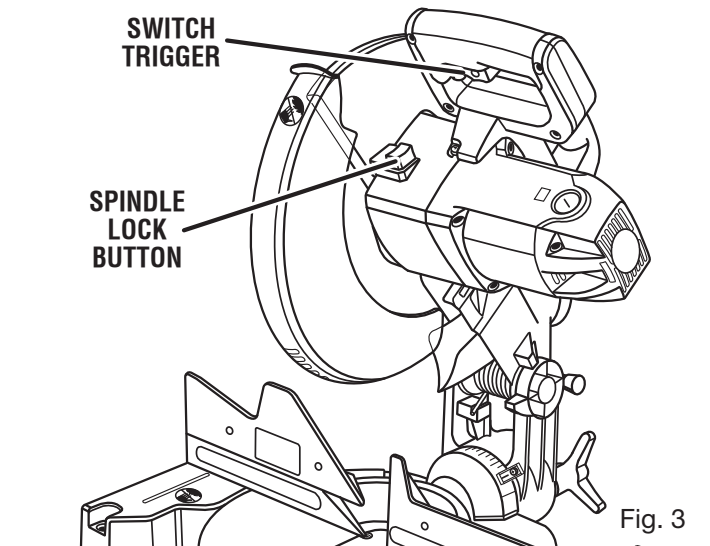

Fig. 3

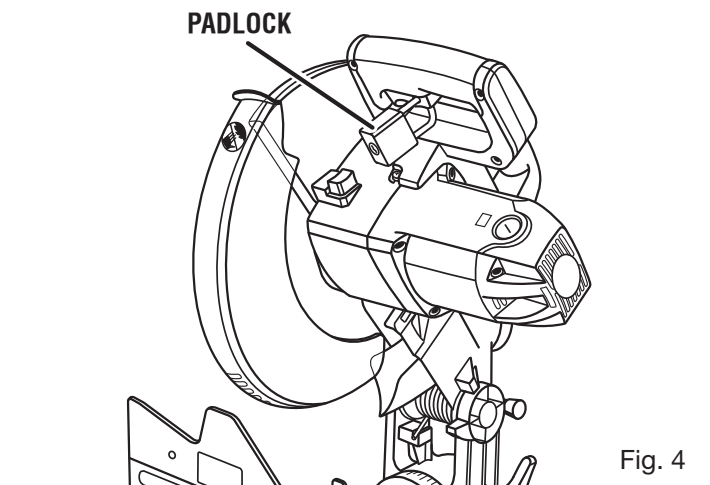

Fig. 4

# FEATURES

## MITER LOCK LEVER

The miter lock lever securely locks the saw at the desired miter angle.

## MITER THUMBWHEEL

The miter thumbwheel, when used with the miter lock lever lifted (unlocked), can release the miter table from pre-set index points. With the thumbwheel spun down (and released), the miter table moves freely to any desired angle. With thumb on thumbwheel, push down and hold to override (bypass) index points; release thumbwheel when close to desired point and move the lock lever into place with a click. With the thumbwheel spun up, the miter table will stop at each index point on the miter scale.

## POSITIVE STOPS ON MITER TABLE

Positive stops have been provided at 0°, 15°, 22.5°, 31.6°, and 45°. The 0°, 15°, 22.5°, 31.6°, and 45° positive stops have been provided on both the left and right side of the miter table.

## REPEAT-A-CUT™

See Figure 5.

The Repeat-A-Cut™ feature on both the left and right side miter fences can be used when making repetitive cuts. Simply mark the fence with a pencil, make the desired number of cut(s), then wipe the mark off with a soft cloth.

## SELF-RETRACTING LOWER BLADE GUARD

The lower blade guard is made of shock-resistant, see-through plastic that provides protection from each side of the blade. It retracts over the upper blade guard as the saw is lowered into the workpiece.

## SPINDLE LOCK BUTTON

See Figure 3.

A spindle lock button has been provided for locking the spindle which keeps the blade in the saw from rotating. Depress and hold the lock button while installing, changing, or removing blade only.

## SLIDING MITER FENCE

The sliding miter fence on your compound miter saw has been provided to hold your workpiece securely against when making all cuts; the left side is larger providing additional support. It has a sliding feature for clearance of the saw arm when making bevel or compound cuts.

Loosen the fence screw before attempting to slide the miter fence. Once the desired position of the miter fence is determined, tighten the fence screw to secure the sliding fence.

## SWITCH TRIGGER

See Figure 4.

To prevent unauthorized use of the compound miter saw, disconnect it from the power supply and lock the switch in the off position. To lock the switch, install a padlock (not included) through the hole in the switch trigger. A lock with a long shackle up to 9/32 in. diameter may be used. When the lock is installed and locked, the switch is inoperable. Store the padlock key in another location.

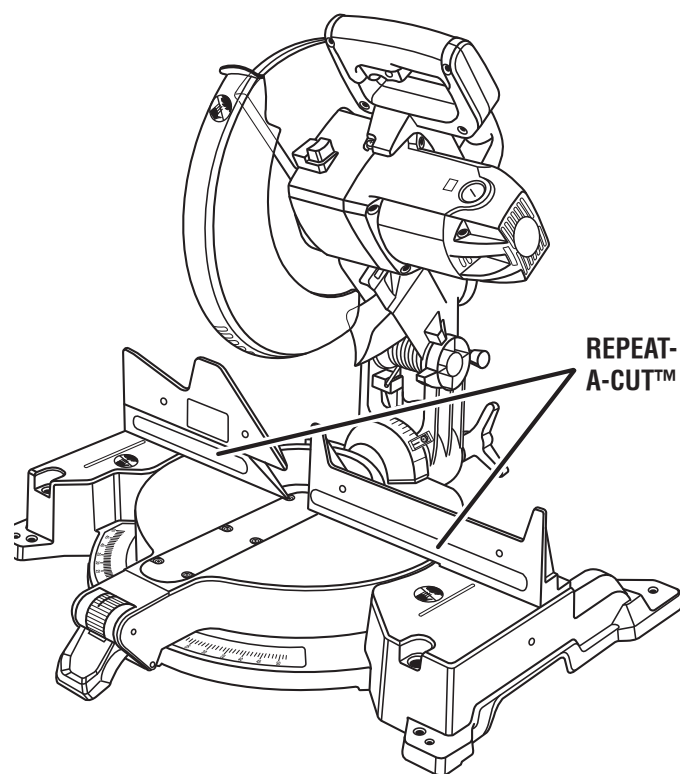

Fig. 5

# TOOLS NEEDED

The following tools (not included) are needed for making adjustments:

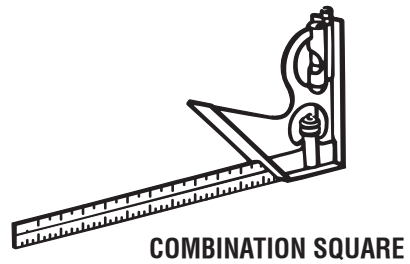
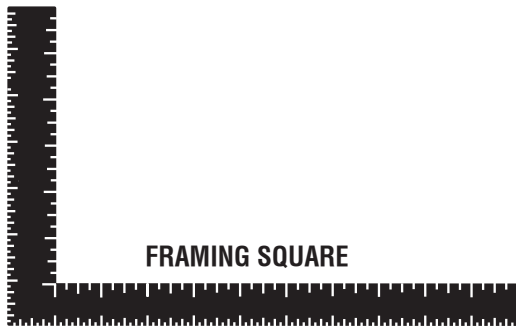

Fig. 6

# LOOSE PARTS

The following items are included with your Compound Miter Saw:

- Dust Bag
- Dust Guide
- Work Clamp
- Table Extension
- Socket Head Screw (2)
- Washer (2)
- Blade Wrench
- Hex Keys (2), 1/16 in., 5/32 in.
- Laser Guide
- Blade Bolt
- Blade
- Operator's Manual (not shown)

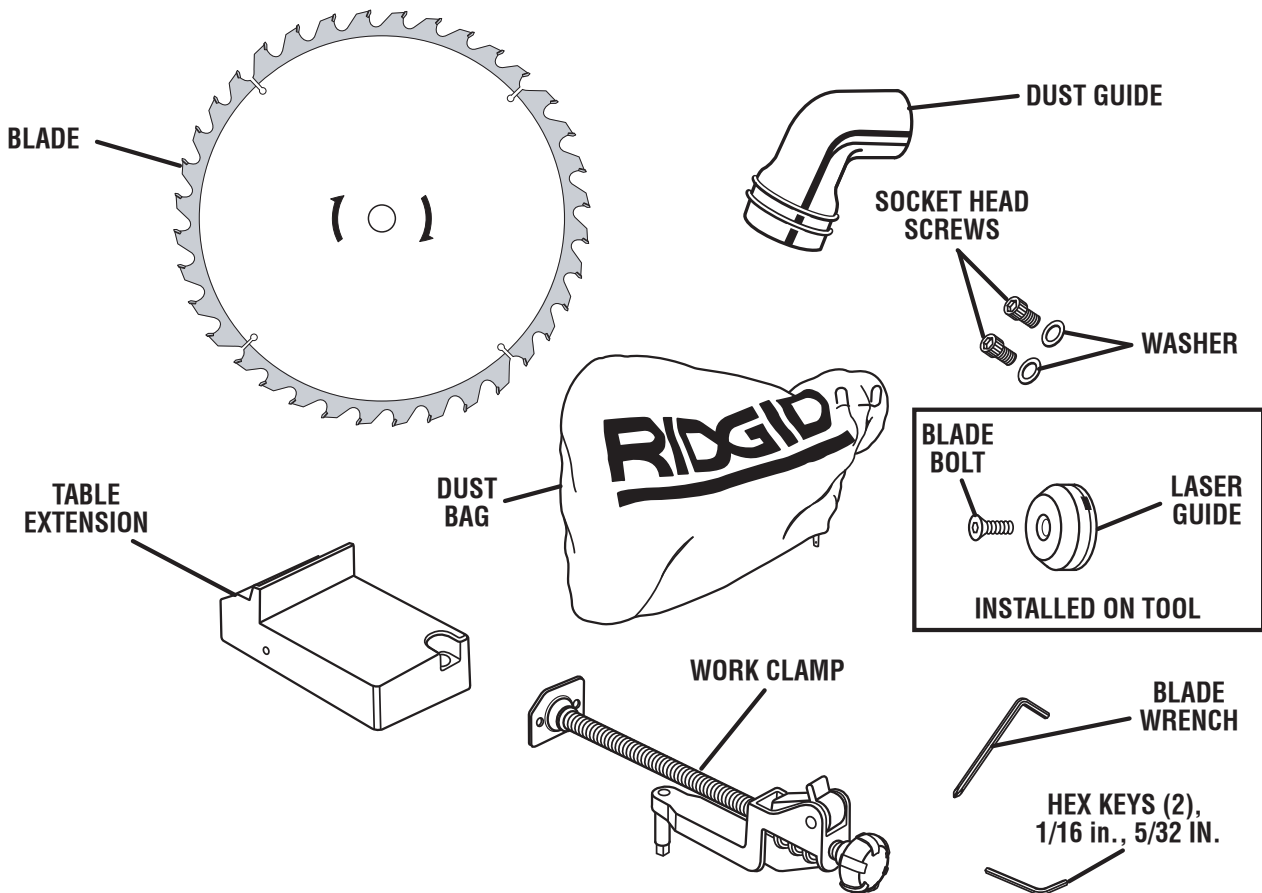

Fig. 7

## **⚠ WARNING:**

The use of attachments or accessories not listed might be hazardous and could cause serious personal injury.



# ASSEMBLY

## UNPACKING

This product requires assembly.

- Carefully lift saw from the carton by the carrying handle and the saw base, and place it on a level work surface.  
**NOTE:** This tool is heavy. To avoid back injury, lift with your legs, not your back, and get help when needed.
- This saw has been shipped with the saw arm secured in the down position. To release the saw arm, push down on the top of the saw arm, cut the tie-wrap, and pull out on the lock pin.
- Lift the saw arm by the handle. Hand pressure should remain on the saw arm to prevent sudden rise upon release of the tie wrap.
- Inspect the tool carefully to make sure no breakage or damage occurred during shipping.
- Do not discard the packing material until you have carefully inspected and satisfactorily operated the tool.
- The saw is factory set for accurate cutting. After assembling it, check for accuracy. If shipping has influenced the settings, refer to specific procedures explained in this manual.
- If any parts are damaged or missing, please call 1-866-539-1710 for assistance.

### **WARNING:**

If any parts are damaged or missing, do not operate this tool until the missing parts are replaced. Failure to heed this warning could result in serious personal injury.

### **WARNING:**

Do not attempt to modify this tool or create accessories not recommended for use with this tool. Any such alteration or modification is misuse and could result in a hazardous condition leading to possible serious personal injury.

### **WARNING:**

Do not connect to power supply until assembly is complete. Failure to comply could result in accidental starting and possible serious personal injury.

### **WARNING:**

Do not start the compound miter saw without checking for interference between the blade and the miter fence. Damage could result to the blade if it strikes the miter fence during operation of the saw.

### **WARNING:**

Always make sure the compound miter saw is securely mounted to a workbench or an approved workstand. Failure to heed this warning can result in serious personal injury.

## MOUNTING HOLES

See Figure 8.

The compound miter saw should be mounted to a firm supporting surface such as a workbench. Four bolt holes have been provided in the saw base for this purpose. Each of the four mounting holes should be bolted securely using 3/8 in. machine bolts, lock washers, and hex nuts (not included). Bolts should be of sufficient length to accommodate the saw base, lock washers, hex nuts, and the thickness of the workbench. Tighten all four bolts securely.

The hole pattern for mounting to a workbench is shown in figure 8. Carefully check the workbench after mounting to make sure that no movement can occur during use. If any tipping, sliding, or walking is noted, secure the workbench to the floor before operating.

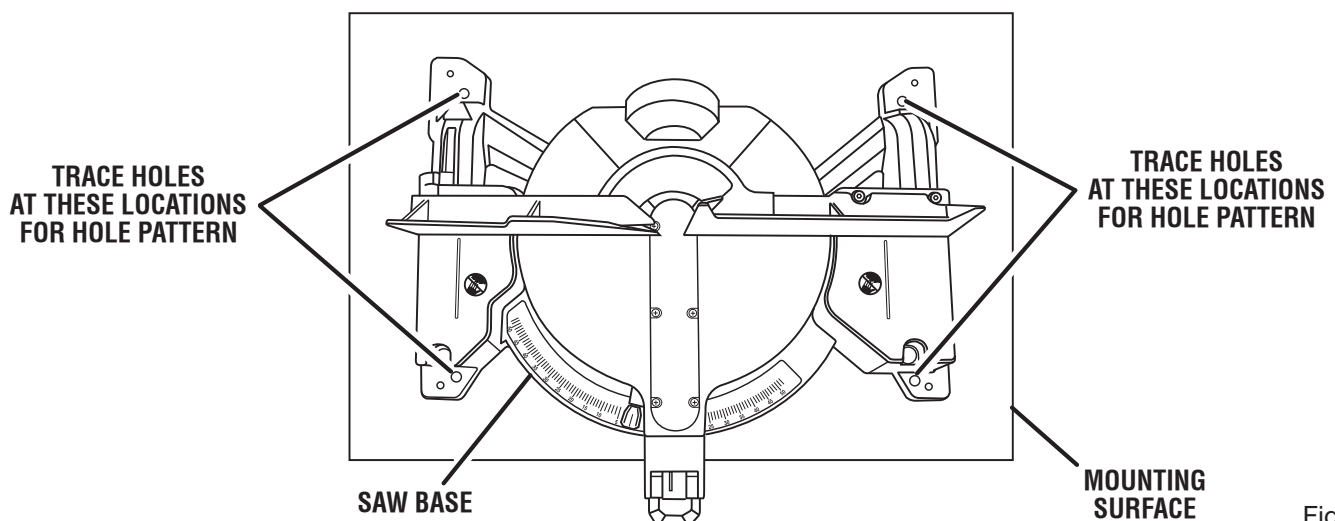

Fig. 8

# ASSEMBLY

**NOTE:** Many of the illustrations in this manual show only portions of the compound miter saw. This is intentional so that we can clearly show points being made in the illustrations. **Never operate the saw without all guards securely in place and in good operating condition.**

## TABLE EXTENSION

See Figure 9.

The table extension can be used on the left side of the miter saw. To assemble and install the table extension:

- Insert socket head screw and washer into the two holes in the side of the miter saw base.
- Lay a framing square flat on the table extension and saw base. Place the square against the fence on the table extension and the fence on the saw base.
- When the table extension and saw base are level and both fences in alignment, tighten screws securely.

## DUST GUIDE

See Figure 10.

Insert the dust guide inside the exhaust port in the upper blade guard. Turn the guide so that the open end is facing down or toward the rear of the saw.

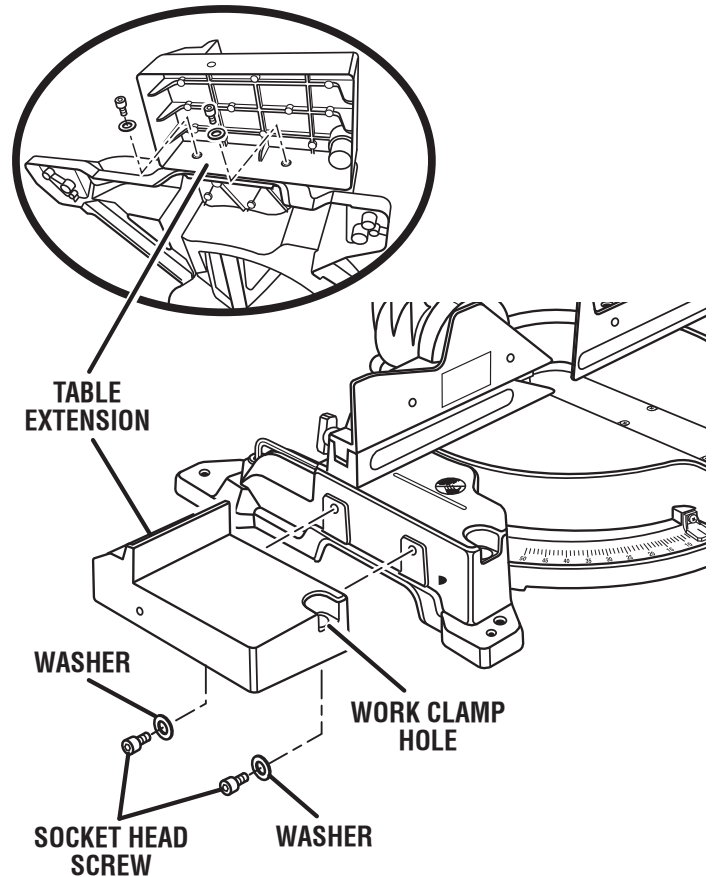

Fig. 9

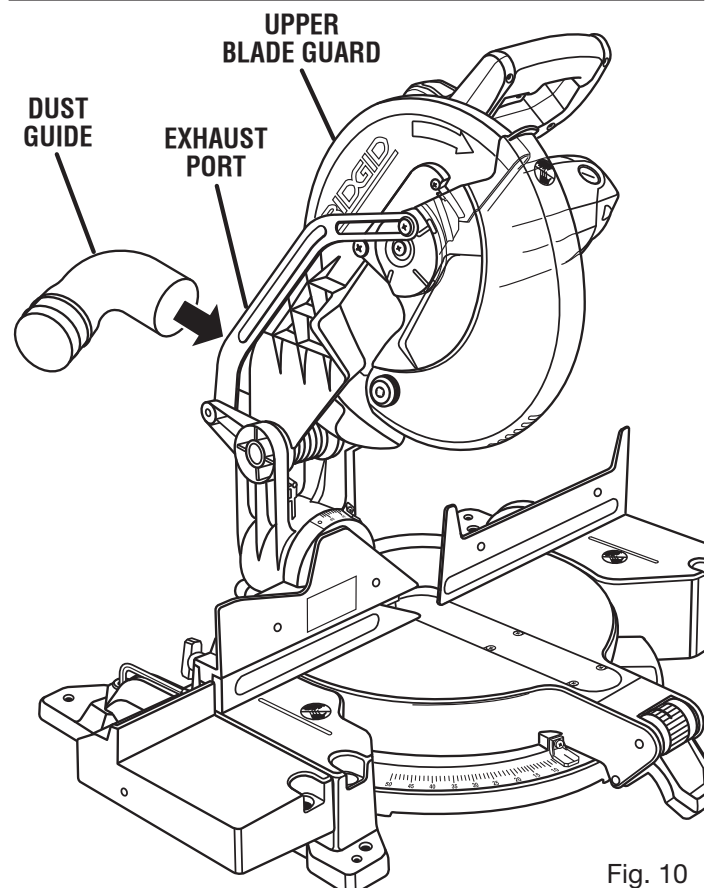

Fig. 10



# ASSEMBLY

## DUST BAG

See Figure 11.

A dust bag is provided for use on this miter saw. It fits over the dust guide on the upper blade guard. To install it, squeeze the two metal clips to open the mouth of the bag and slide it on the dust guide. Release the clips. The metal ring in the bag should lock in between the grooves on the dust guide.

To remove the dust bag for emptying, simply reverse the above procedure.

## WORK CLAMP

See Figure 12.

### **⚠ WARNING:**

In some operations, the work clamp assembly may interfere with the operation of the blade guard assembly. Always make sure there is no interference with the blade guard prior to beginning any cutting operation to reduce the risk of serious personal injury.

The work clamp provides greater control by clamping the workpiece to the fence. It also prevents the workpiece from creeping toward the saw blade. This is very helpful when cutting compound miters.

Depending on the cutting operation and the size of the workpiece, it may be necessary to use a C-clamp instead of the work clamp to secure the workpiece prior to making the cut.

### **To install the work clamp:**

- Place the shaft of the work clamp in either hole on the saw table base or the hole in the table extension.
- Rotate the knob on the work clamp to move it in or out as needed.

**NOTE:** The work clamp has a quick release lever that makes positioning of the work clamp effortless.

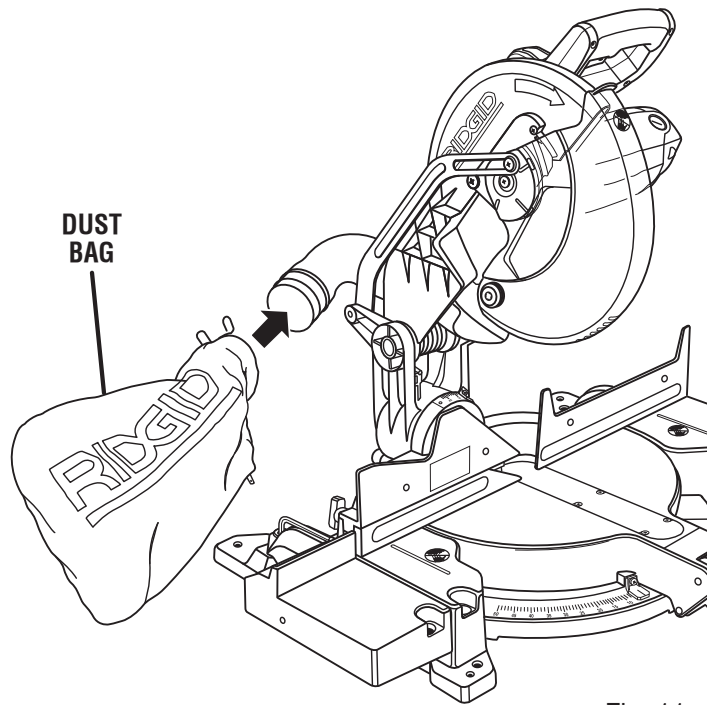

Fig. 11

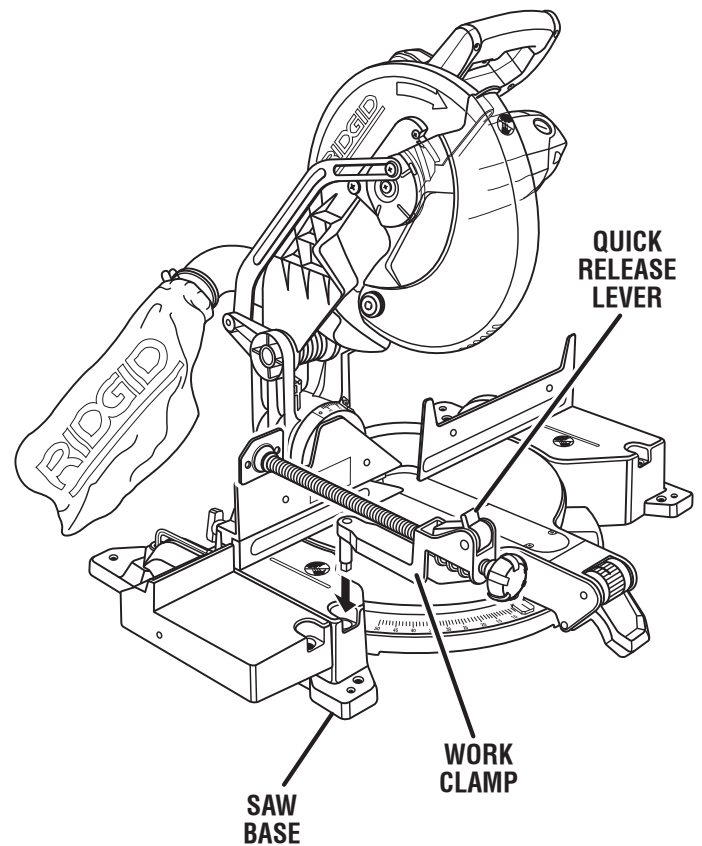

Fig. 12

# ASSEMBLY

## TO INSTALL THE BLADE

See Figure 13.

### **WARNING:**

A 12 in. blade is the maximum blade capacity of the saw. Never use a blade that is too thick to allow outer blade washer to engage with the flats on the spindle. Larger blades will come in contact with the blade guards, while thicker blades will prevent the blade bolt from securing the blade on the spindle. Either of these situations could result in a serious accident and can cause serious personal injury.

- Unplug the saw.
- Once blade has stopped, raise saw arm.
- Remove screw. Rotate blade bolt cover up and back to expose the blade bolt.
- Depress the spindle lock button and rotate the blade bolt until the spindle locks.
- Using the wrench provided, loosen and remove the blade bolt.

**NOTE:** The blade bolt has left hand threads. Turn blade bolt clockwise to loosen.

- Remove the laser guide. **Do not** remove the inner blade washer.
- Wipe a drop of oil onto the inner blade washer and the outer blade washer or laser guide where they contact the blade.

### **WARNING:**

If inner blade washer has been removed, replace it before placing blade on spindle. Failure to do so could cause an accident since blade will not tighten properly.

- Fit saw blade inside upper blade guard and onto spindle. The blade teeth point downward at the front of saw as shown in figure 13.

### **CAUTION:**

Always install the blade with the blade teeth and the arrow printed on the side of the blade pointing down at the front of the saw. The direction of blade rotation is also stamped with an arrow on the upper blade guard.

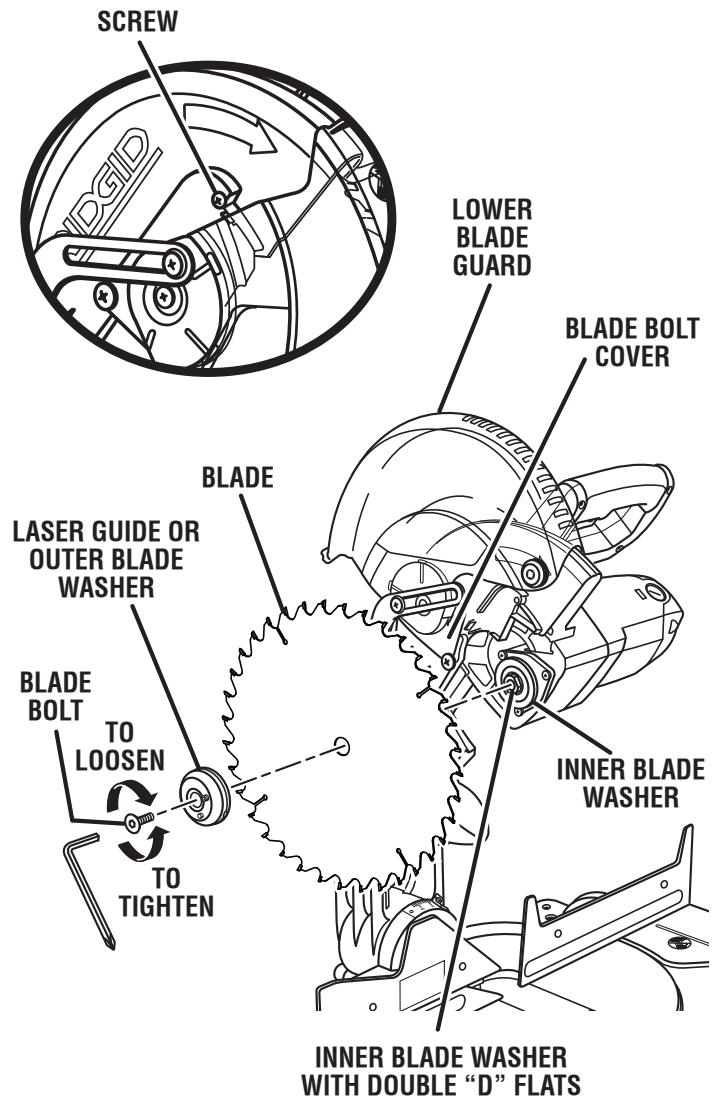

Fig. 13

- Replace the laser guide. The double "D" flats on the blade washers align with the flats on the spindle.
- Depress spindle lock button and replace blade bolt.  
**NOTE:** The blade bolt has left hand threads. Turn blade bolt counterclockwise to tighten.
- Tighten blade bolt securely.
- Lower the blade guard and blade bolt cover.
- Replace screw and tighten securely.

# ASSEMBLY

## **WARNING:**

Make sure the spindle lock button is not engaged before reconnecting saw into power source. Never engage spindle lock button when blade is rotating.

## **DANGER:**

Laser radiation. Avoid direct eye contact with light source.

## **ALIGNING THE LASER GUIDE LINE**

See Figure 14.

The laser guide will generate a colored line on the work surface when the blade is spinning. The laser line will appear as a broken line on the workpiece when the blade assembly is in the uppermost position and the motor switch is activated. This broken line will let you see your mark and your laser guide line at the same time, and will assist you in lining up your mark for more accurate cutting of the workpiece.

### **To Cut Your Mark:**

- Using a sharp pencil, mark a line on the workpiece.
- With the saw blade in the uppermost position, align the laser line with your mark. Once both lines are in alignment, do not move the workpiece until after you have finished cutting.

**NOTE:** As the saw blade assembly is lowered toward the workpiece, the broken line will become solid. The solid line will drift away from the mark as the saw blade gets closer to the workpiece. This is normal. The blade will cut on the mark. NEVER attempt to move the workpiece while making a cut. Always keep hands outside the “No Hands Zone”.

- Make several practice cuts on different styles and thickness of material.

### **To Remove Your Mark:**

- Position the laser line near the left edge of your mark on the work surface in order to remove the mark.

### **To Leave Your Mark:**

- Position the laser line near the right edge of your mark on the work surface in order to leave the mark.

After you have become familiar with using the laser guide, you will be able to remove, cut, or leave your mark on the work surface. Practice will teach you the correct position for aligning the laser line with your mark.

## **CUTTING A SLOT IN THE ZERO CLEARANCE THROAT PLATE**

In order to use your compound miter saw, you must cut a slot through the zero clearance throat plate to allow for blade clearance. To cut the slot, set your saw at 0° miter, turn saw on and allow the blade to reach full speed, then carefully make a straight cut as far as it will go through the throat plate. Turn your saw off and allow the blade to come to a complete stop before raising the saw arm.

Next, adjust the bevel angle to 45°, turn your saw on and allow the blade to reach full speed, then carefully make another cut through the zero clearance throat plate. The slot in the throat plate will then be wide enough to allow the blade to pass through it at any angle from 0° to 45°.

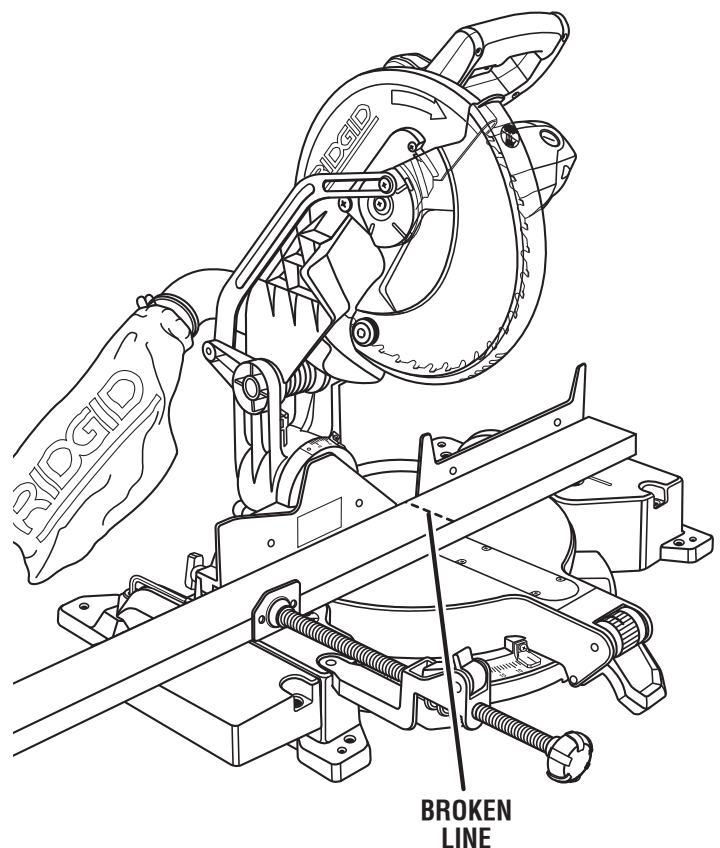

Fig. 14

# ASSEMBLY

## ADJUSTING THE MITER LOCK LEVER

See Figures 15 - 16.

Prior to squaring the saw blade to the fence, check and align the miter lock lever. The blade must be set at an “unindexed” miter position other than 0°, 15°, 22.5°, 31.6°, and 45° to test. In the “locked” position, the action of pushing the miter lock lever down should feel tight and secure. Considerable effort should be required to move the miter table. If the table moves easily when in the “locked” position, an adjustment of the miter lock lever is required.

### To adjust:

- Unplug the saw.
- Lift the miter lock lever to unlock.
- Locate the set screw under the miter lock lever.
- Using a hex key, adjust the set screw until the proper amount of tension in the lock lever is attained.
- Once all adjustments have been made, push the miter lock lever down to relock the miter table.

## SQUARING THE SAW BLADE TO THE FENCE

See Figures 17 - 22

- Unplug the saw.
- Pull the saw arm all the way down and lock in transport position.
- Lift the miter lock lever.
- Rotate the miter table until the pointer on the miter scale is positioned at 0°.
- Lock the miter lock lever by pushing it down.
- Remove the sliding miter fence by loosening the fence screw and lifting the sliding miter fence off the saw.
- Lay a framing square flat on the miter table. Place one leg of the square against the fence. Slide the other leg of the square against the flat part of saw blade.

**NOTE:** Make sure that the square contacts the flat part of the saw blade, not the blade teeth.

- The edge of the square and the saw blade should be parallel as shown in figure 17.
- If the front or back edge of the saw blade angles away from the square as shown in figures 19 and 20, adjustments are needed.

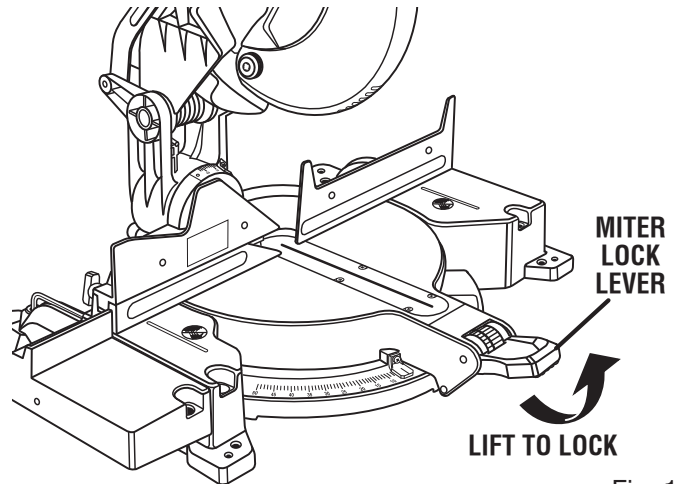

Fig. 15

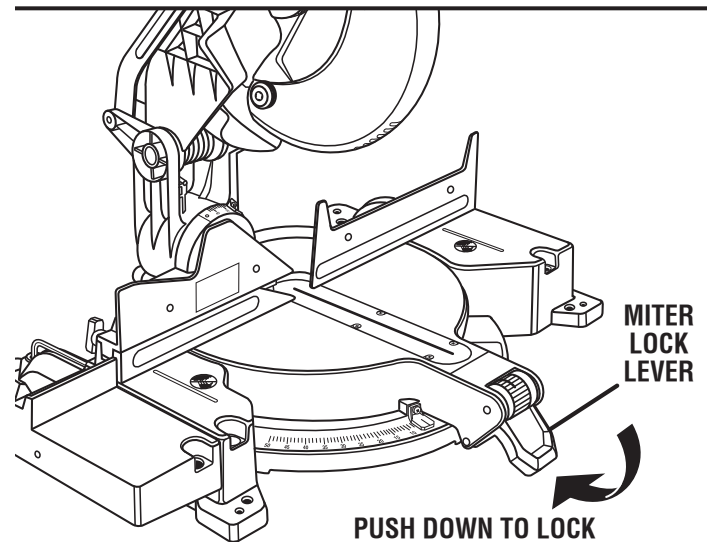
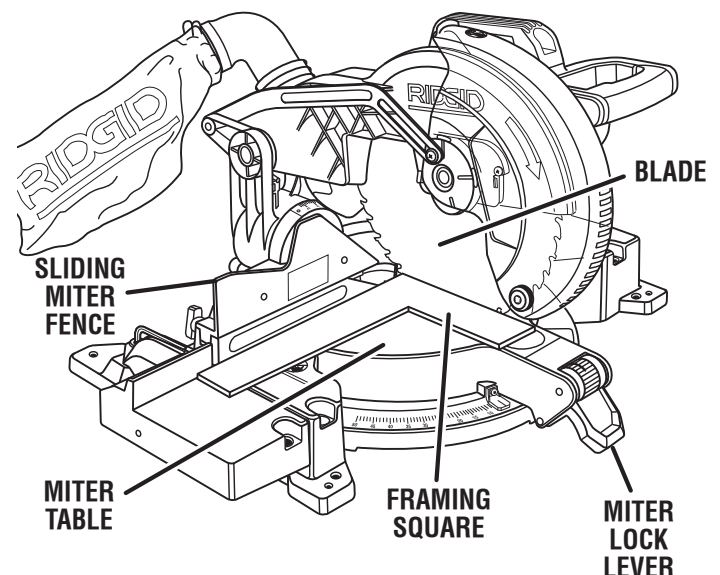

Fig. 16



VIEW OF BLADE SQUARE WITH FENCE

Fig. 17



# ASSEMBLY

- Loosen the socket head screws that secure the fence to the miter table. See Figure 18.
- Rotate the fence left or right until the saw blade is parallel with the square.
- Retighten the socket head screws securely and recheck the blade-to-fence alignment.

Your saw has several scale indicators. After squaring adjustments have been made, it may be necessary to loosen the indicator screws and reset them to zero. See Figures 21 - 22.

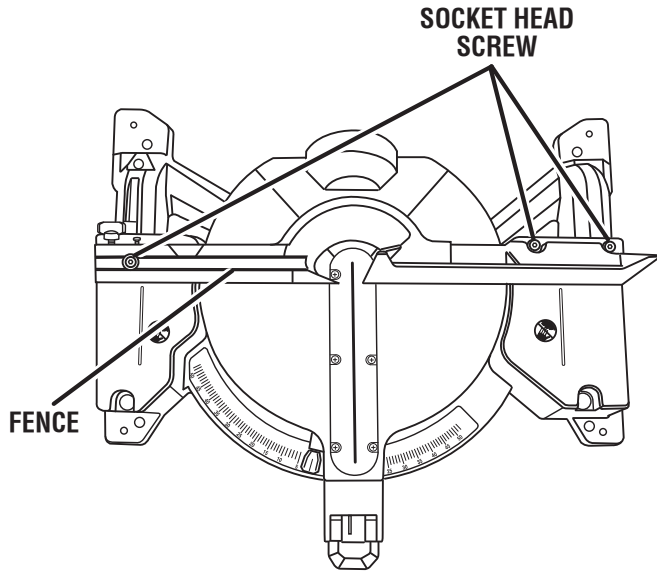
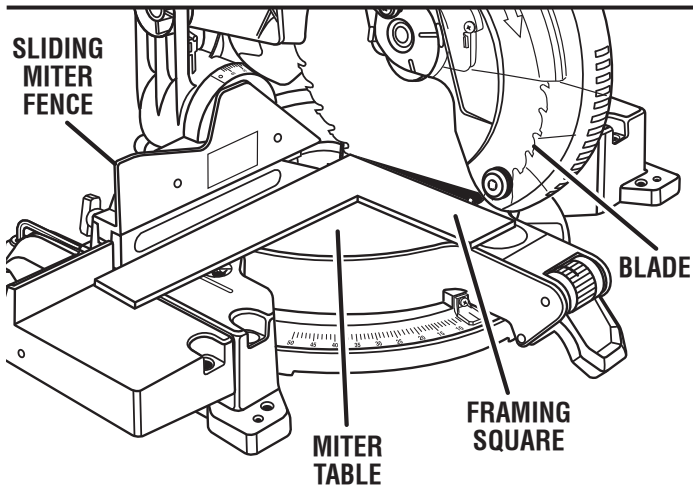
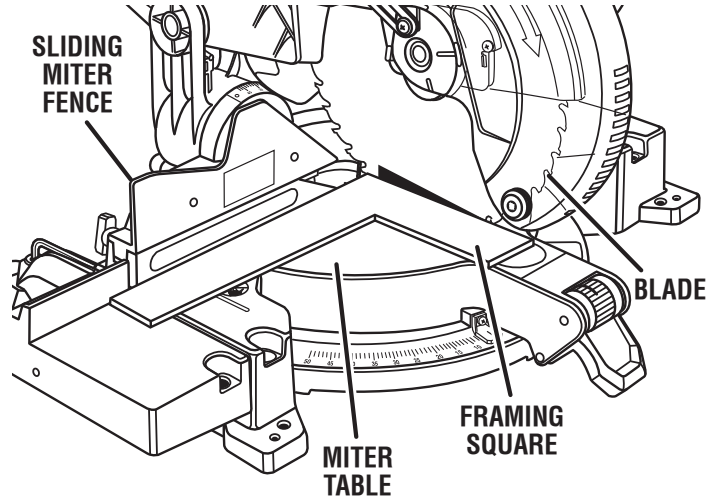

Fig. 18



VIEW OF BLADE NOT SQUARE WITH FENCE, ADJUSTMENTS ARE REQUIRED

Fig. 19



VIEW OF BLADE NOT SQUARE WITH FENCE, ADJUSTMENTS ARE REQUIRED

Fig. 20

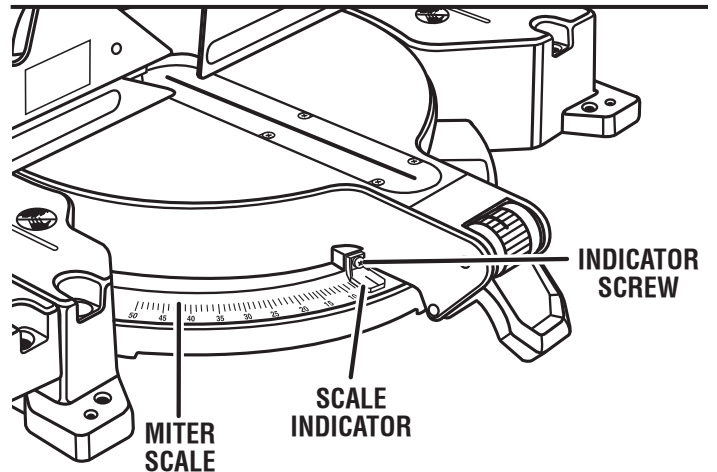

Fig. 21

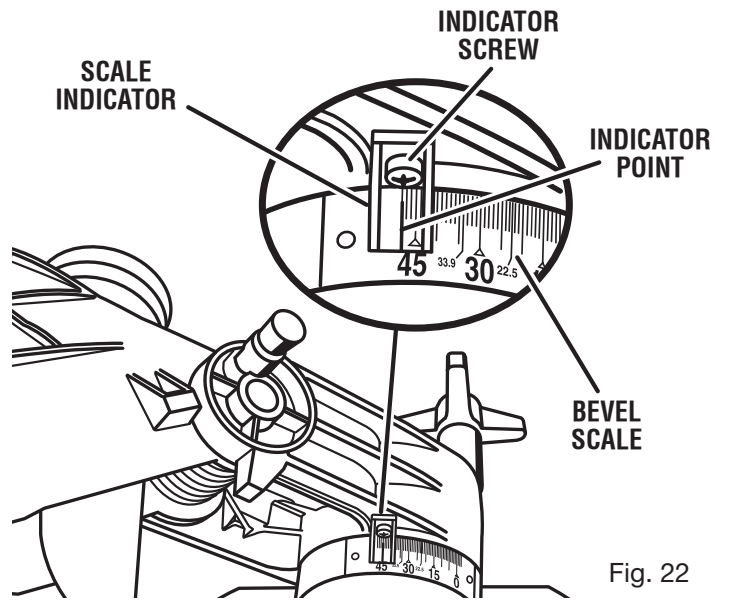

Fig. 22

# ASSEMBLY

## SQUARING THE BLADE TO THE MITER TABLE

See Figures 22 - 25.

- Unplug the saw.
- Pull the saw arm all the way down and lock in transport position.
- Lift the miter lock lever.
- Rotate the miter table until the pointer on the miter scale is positioned at 0°.
- Lock the miter lock lever by pushing it down.
- Loosen bevel lock knob and set saw arm at 0° bevel (blade set 90° to miter table). Tighten bevel lock knob.
- Place a combination square against the miter table and the flat part of saw blade.

**NOTE:** Make sure that the square contacts the flat part of the saw blade, not the blade teeth.

- Rotate the blade by hand and check the blade-to-table alignment at several points.
- The edge of the square and the saw blade should be parallel as shown in figure 23.
- If the top or bottom of the saw blade angles away from the square as shown in figures 24 and 25, adjustments are needed.
- Loosen the bevel lock knob.
- Using the blade wrench, loosen the bevel stop adjustment screw and slide the bevel stop left or right as needed to bring the saw blade into alignment with the square. Retighten bevel stop adjustment screw. See Figure 26.
- Retighten bevel lock knob. Recheck blade-to-table alignment.

**NOTE:** The above procedure can be used to check blade squareness of the saw blade to the miter table at both 0° and 45° angles.

Your saw has several scale indicators. After squaring adjustments have been made, it may be necessary to loosen the indicators screws and reset them to zero. See Figures 21 and 22.

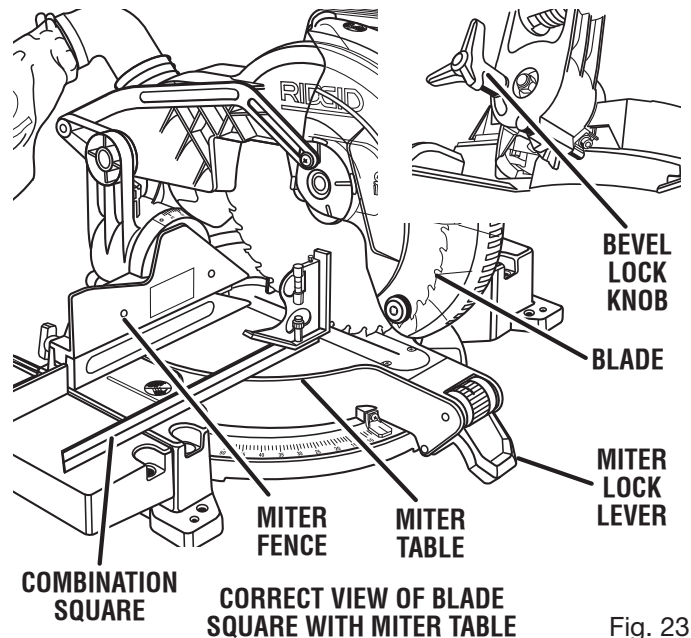
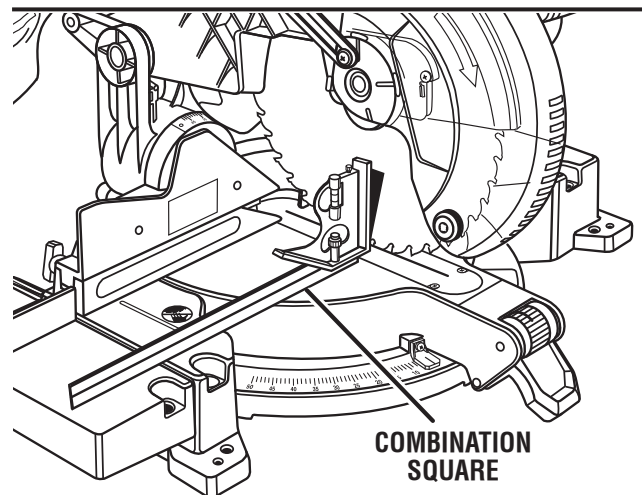
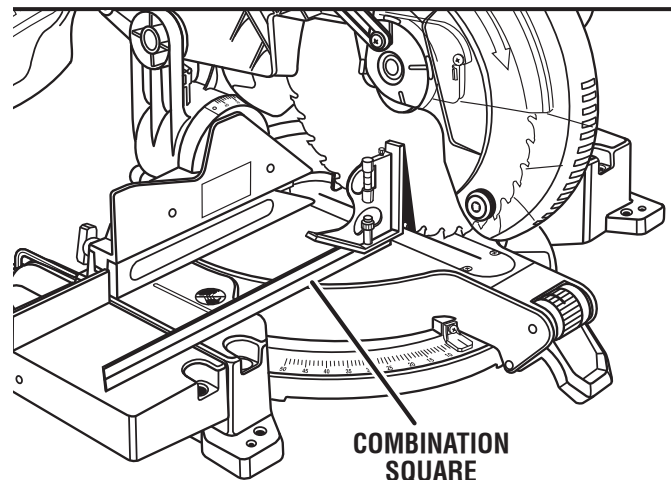

Fig. 23



VIEW OF BLADE NOT SQUARE WITH MITER TABLE, ADJUSTMENTS ARE REQUIRED

Fig. 24



VIEW OF BLADE NOT SQUARE WITH MITER TABLE, ADJUSTMENTS ARE REQUIRED

Fig. 25

# ASSEMBLY

## PIVOT ADJUSTMENTS

**NOTE:** These adjustments were made at the factory and normally do not require readjustment.

### TRAVEL PIVOT ADJUSTMENT

- The saw arm should rise completely to the up position by itself.
- If the saw arm does not raise by itself or if there is play in the pivot joints, have saw repaired at your nearest **AUTHORIZED SERVICE CENTER.**

### BEVEL PIVOT ADJUSTMENT

- The compound miter saw should bevel easily by loosening the bevel lock knob and tilting the saw arm to the left.
- If movement is tight or if there is play in the pivot, have saw repaired at your nearest **AUTHORIZED SERVICE CENTER.**

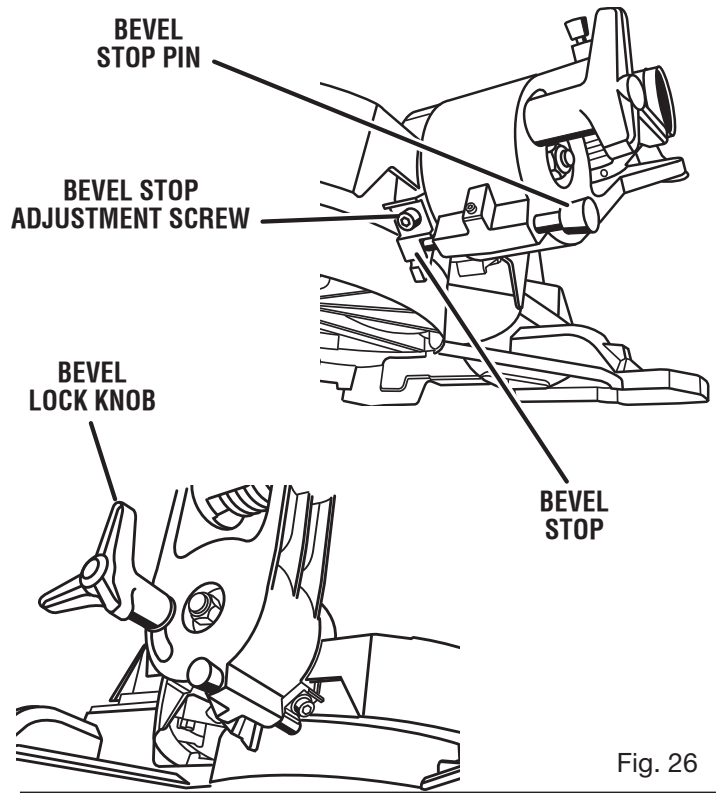

Fig. 26



# OPERATION

---

## **WARNING:**

Do not allow familiarity with tools to make you careless. Remember that a careless fraction of a second is sufficient to inflict severe injury.

---

## **WARNING:**

Always wear safety goggles or safety glasses with side shields when operating tools. Failure to do so could result in objects being thrown into your eyes resulting in possible serious injury.

---

## **WARNING:**

Do not use any attachments or accessories not recommended by the manufacturer of this tool. The use of attachments or accessories not recommended can result in serious personal injury.

---

## **APPLICATIONS**

This product has been designed only for the purposes listed below:

- Cross cutting wood and plastic.
- Cross cutting miters, joints, etc. for picture frames, moldings, door casings, and fine joinery.

**NOTE:** The blade provided is fine for most wood cutting operations, but for fine joinery cuts or cutting plastic, use one of the accessory blades available from the RIDGID dealer.

---

## **WARNING:**

Before starting any cutting operation, clamp or bolt your miter saw to a workbench. Never operate your miter saw on the floor or in a crouched position. Failure to heed this warning can result in serious personal injury.

---

## **WARNING:**

To avoid serious personal injury, keep your hands outside the no hands zone; at least 3 in. from blade. Never perform any cutting operation freehand (without holding workpiece against the fence). The blade could grab the workpiece if it slips or twists.

---

## **WARNING:**

Do not start your compound miter saw without checking for interference between the blade and the miter fence. Damage could result to the blade if it strikes the miter fence during operation of the saw. Failure to heed this warning can also result in serious personal injury.

---

## **CUTTING WITH YOUR COMPOUND MITER SAW**

---

### **WARNING:**

When using a work clamp or C-clamp to secure your workpiece, clamp workpiece on one side of the blade only. The workpiece must remain free on one side of the blade to prevent the blade from binding in workpiece. The workpiece binding the blade will cause motor stalling and kickback. This situation could cause an accident resulting in possible serious personal injury.

---

### **WARNING:**

To avoid serious personal injury, always tighten the miter lock handle securely before making a cut. Failure to do so could result in movement of the control arm or miter table while making a cut.

---

## **MITER THUMBWHEEL**

The miter thumbwheel, when used with the miter lock lever lifted (unlocked), can release the miter table from pre-set index points.

### **To align with miter scale:**

- Lift the miter lock lever to unlock.
- Rotate and hold thumbwheel so that the yellow dot on the thumbwheel aligns with indicator point (white dot) on the miter lock lever to override index points.
- When close to desired angle, release the thumbwheel.  
**NOTE:** When the orange dot on the thumbwheel clicks into place (aligned with the indicator point), the miter table is locked into a preset index point.
- Push the miter lock lever down to lock the miter table.

### **To bypass preset index points:**

- Lift the miter lock lever to unlock.
- Rotate the thumbwheel so that the white dot on the thumbwheel aligns with the indicator point (white dot) on the miter lock lever.

# OPERATION

## TO MITER CUT / CROSS CUT

See Figures 27 - 28.

A cross cut is made by cutting across the grain of the workpiece. A straight cross cut is made with the miter table set at the 0° position. Miter cross cuts are made with the miter table set at some angle other than zero.

- Pull out the lock pin and lift saw arm to its full height.
- Lift the miter lock lever to unlock. Rotate the miter table until the pointer aligns with the desired angle on the miter scale.

**NOTE:** You can quickly locate 0°, 15°, 22.5°, 31.6°, and 45° left or right by spinning the miter thumbwheel up. The lock plate will seat itself in one of the positive stop notches, located in the miter table base.

- Push the miter lock lever down to lock the miter table.
- Place the workpiece flat on the miter table with one edge securely against the fence. If the board is warped, place the convex side against the fence. If the concave edge of a board is placed against the fence, the board could collapse on the blade at the end of the cut, jamming the blade. See Figures 36 - 37.
- When cutting long pieces of lumber or molding, support the opposite end of the stock with a roller stand or with a work surface level with the saw table. See Figure 31.
- Align cutting line on the workpiece with the edge of saw blade.
- Grasp the stock firmly with one hand and secure it against the fence. Use the work clamp or a C-clamp to secure the workpiece when possible.
- Before turning on the saw, perform a dry run of the cutting operation to make sure that no problems will occur when the cut is made.
- Grasp the saw handle firmly. Depress the switch lock with thumb then squeeze the switch trigger. Allow several seconds for the blade to reach maximum speed.
- Slowly lower the blade into and through the workpiece.
- Release the switch trigger and allow the saw blade to stop rotating before raising the blade out of workpiece and removing the workpiece from the miter table.

## CROSS CUT

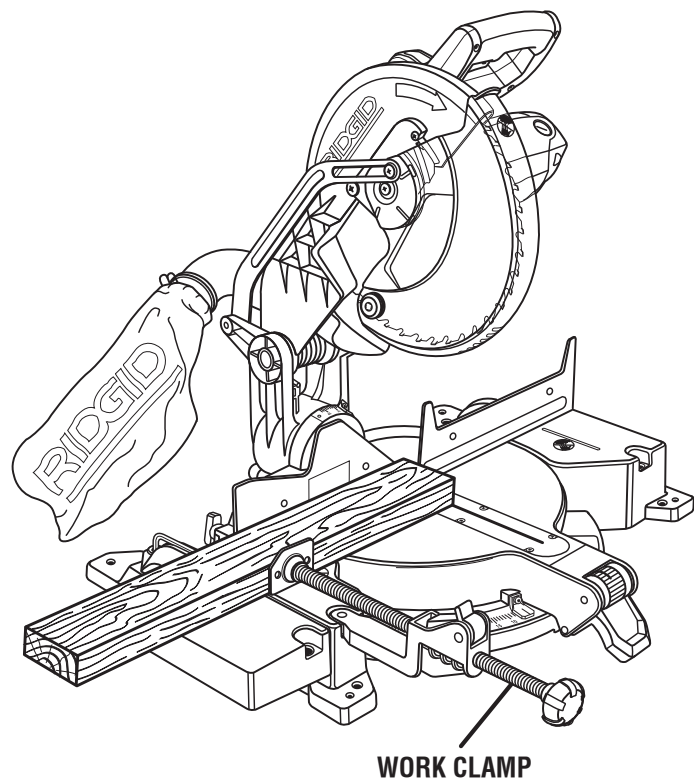

Fig. 27

## MITER CUT

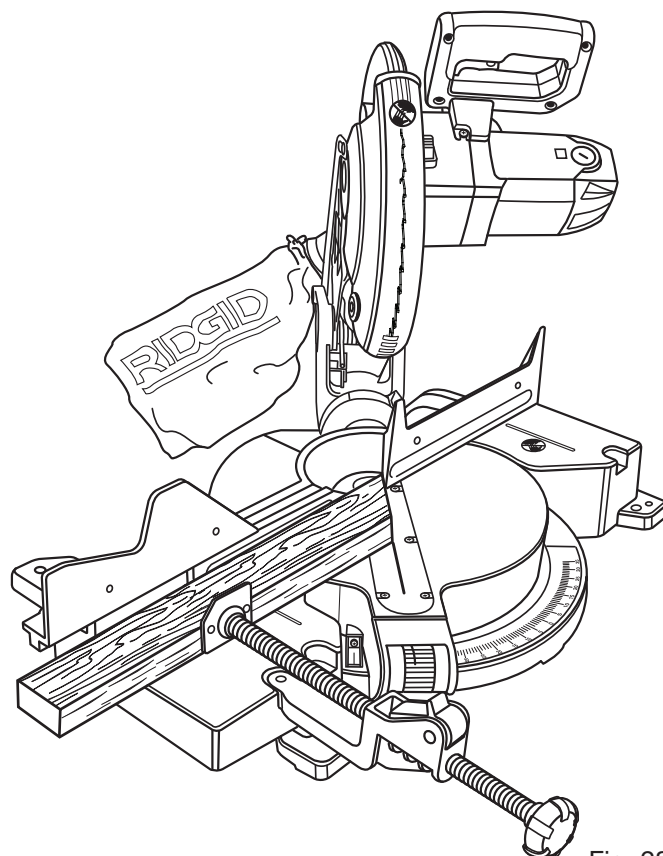

Fig. 28

# OPERATION

## TO BEVEL CUT

See Figure 29.

A bevel cut is made by cutting across the grain of the workpiece with the blade angled to the workpiece. A straight bevel cut is made with the miter table set at the zero degree position and the blade set at an angle between  $-3^{\circ}$  and  $48^{\circ}$ .

**NOTE:** It may be necessary to adjust or remove the sliding miter fence and/or move the work clamp to the hole in the table extension to insure proper clearance prior to making the cut.

- Pull out the lock pin and lift saw arm to its full height.
- Lift the miter lock lever to unlock. Rotate the miter table until the pointer aligns with zero on the miter scale.
- Push the miter lock lever down to lock the miter table.
- Loosen the bevel lock knob and move the saw arm to the left to the desired bevel angle.
- Once the saw arm has been set at the desired angle, securely tighten the bevel lock knob.
- Place the workpiece flat on the miter table with one edge securely against the fence. If the board is warped, place the convex side against the fence. If the concave edge of a board is placed against the fence, the board could collapse on the blade at the end of the cut, jamming the blade. See Figures 36 - 37.
- When cutting long pieces of lumber or molding, support the opposite end of the stock with a roller stand or with a work surface level with the saw table. See Figure 31.
- Align the cutting line on the workpiece with the edge of saw blade.
- Grasp the stock firmly with one hand and secure it against the fence. Use the work clamp or a C-clamp to secure the workpiece when possible.
- Before turning on the saw, perform a dry run of the cutting operation to make sure that no problems will occur when the cut is made.
- Grasp the saw handle firmly. Depress the switch lock with thumb then squeeze the switch trigger. Allow several seconds for the blade to reach maximum speed.
- Slowly lower the blade into and through the workpiece.
- Release the switch trigger and allow the saw blade to stop rotating before raising the blade out of workpiece and removing the workpiece from the miter table.

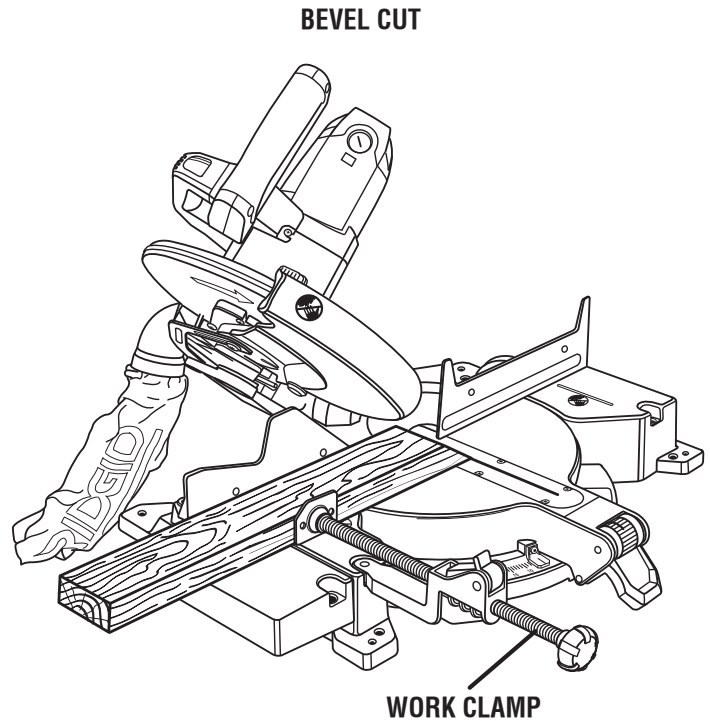

Fig. 29

# OPERATION

## TO COMPOUND MITER CUT

See Figure 30.

A compound miter cut is a cut made using a miter angle and a bevel angle at the same time. This type of cut is used to make picture frames, cut molding, make boxes with sloping sides, and for certain roof framing cuts.

To make this type of cut the control arm on the miter table must be rotated to the correct angle and the saw arm must be tilted to the correct bevel angle. Care should always be taken when making compound miter setups due to the interaction of the two angle settings.

Adjustments of miter and bevel settings are interdependent with one another. Each time you adjust the miter setting you change the effect of the bevel setting. Also, each time you adjust the bevel setting you change the effect of the miter setting.

It may take several settings to obtain the desired cut. The first angle setting should be checked after setting the second angle, since adjusting the second angle affects the first.

Once the two correct settings for a particular cut have been obtained, always make a test cut in scrap material before making a finish cut in good material.

**NOTE:** It may be necessary to adjust or remove the sliding miter fence and/or move the work clamp to the hole in the table extension to insure proper clearance prior to making the cut.

- Raise saw arm to its full height.
- Lift the miter lock lever to unlock. Rotate the miter table until the pointer aligns with the desired angle on the miter scale.

**NOTE:** You can quickly locate 0°, 15°, 22.5°, 31.6°, and 45° left or right by spinning the miter thumbwheel up. The lock plate will seat itself in one of the positive stop notches, located in the miter table base.

- Push the miter lock lever down to lock the miter table.
- Loosen the bevel lock knob and move the saw arm to the left to the desired bevel angle.
- Once the saw arm has been set at the desired angle, securely tighten the bevel lock knob.
- Place the workpiece flat on the miter table with one edge securely against the fence. If the board is warped, place the convex side against the fence. If the concave edge of a board is placed against the fence, the board could collapse on the blade at the end of the cut, jamming the blade. See Figures 36 - 37.

## COMPOUND MITER CUT

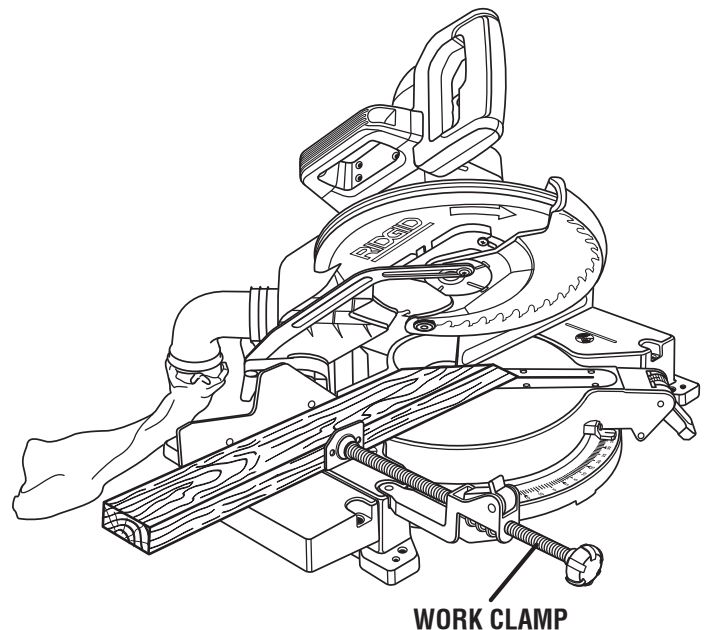

Fig. 30

- When cutting long pieces of lumber or molding, support the opposite end of the stock with a roller stand or with a work surface level with the saw table. See Figure 31.
- Align the cutting line on the workpiece with the edge of saw blade.
- Grasp the stock firmly with one hand and secure it against the fence. Use the work clamp or a C-clamp to secure the workpiece when possible.
- Before turning on the saw, perform a dry run of the cutting operation to make sure that no problems will occur when the cut is made.
- Make a test cut in scrap material.
- Grasp the saw handle firmly. Depress the switch lock with thumb then squeeze the switch trigger. Allow several seconds for the blade to reach maximum speed.
- Slowly lower the blade into and through the workpiece.
- Release the switch trigger and allow the saw blade to stop rotating before raising the blade out of workpiece and removing the workpiece from the miter table.



# OPERATION

## SUPPORTING LONG WORKPIECES

See Figures 31 - 32.

Long workpieces need extra supports. Supports should be placed along the workpiece so it does not sag. The support should let the workpiece lay flat on the base of the saw and miter table during the cutting operation. Use the work clamp to secure the workpiece.

**NOTE:** When making a compound miter cut as shown in figure 32, it may be necessary to adjust or remove the sliding miter fence and/or move the work clamp to the hole in the table extension to insure proper clearance prior to making the cut.

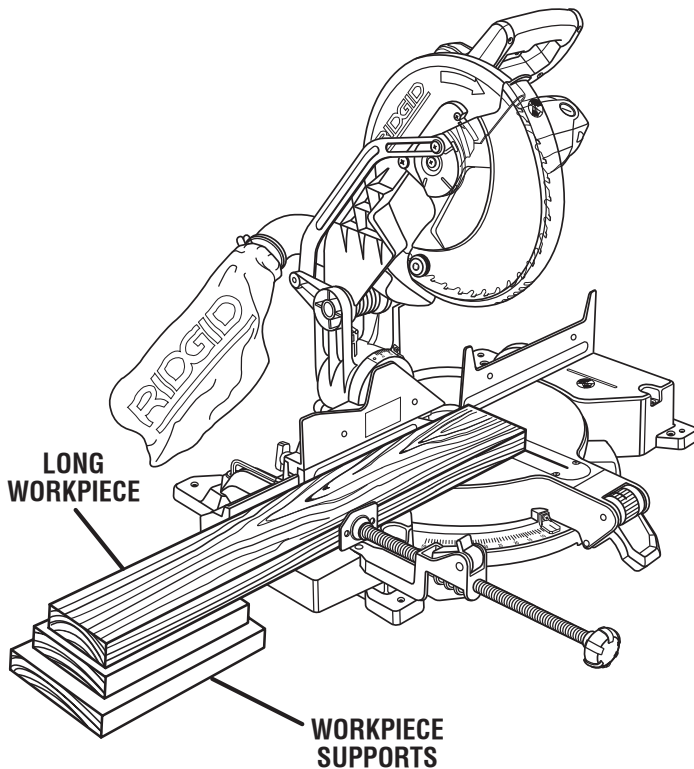
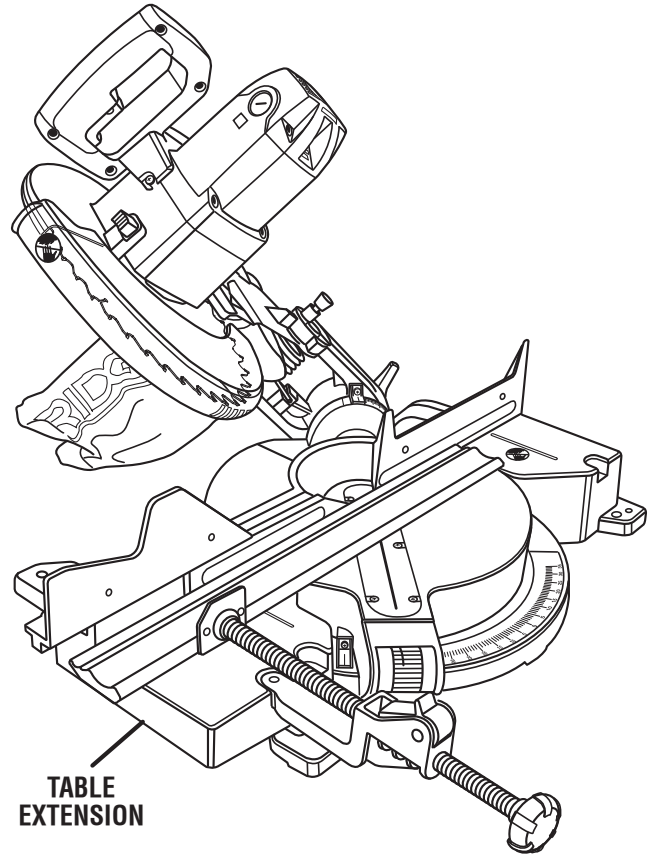

Fig. 31



45° x 45° COMPOUND MITER CUT

Fig. 32

## CLAMPING WIDE WORKPIECES

See Figure 33.

When cutting wide workpieces, such as 2 in. x 6 in., boards should be clamped with the work clamp.

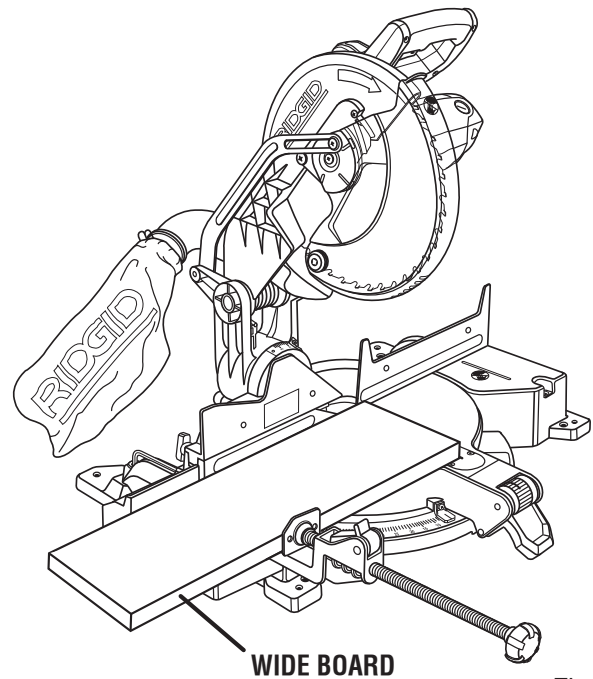

WIDE BOARD

Fig. 33

# OPERATION

## CUTTING COMPOUND MITERS

To aid in making the correct settings, the compound angle setting chart below has been provided. Since compound cuts are the most difficult to accurately obtain, trial cuts should be made in scrap material, and much thought and planning made, prior to making your required cut.

PITCH OF SIDE	NUMBER OF SIDES						
	4	5	6	7	8	9	10
0°	M- 45.00° B- 0.00°	M- 36.00° B- 0.00°	M- 30.00° B- 0.00°	M- 25.71° B- 0.00°	M- 22.50° B- 0.00°	M- 20.00° B- 0.00°	M- 18.00° B- 0.00°
5°	M- 44.89° B- 3.53°	M- 35.90° B- 2.94°	M- 29.91° B- 2.50°	M- 25.63° B- 2.17°	M- 22.42° B- 1.91°	M- 19.93° B- 1.71°	M- 17.94° B- 1.54°
10°	M- 44.56° B- 7.05°	M- 35.58° B- 5.86°	M- 29.62° B- 4.98°	M- 25.37° B- 4.32°	M- 22.19° B- 3.81°	M- 19.72° B- 3.40°	M- 17.74° B- 3.08°
15°	M- 44.01° B- 10.55°	M- 35.06° B- 8.75°	M- 29.15° B- 7.44°	M- 24.95° B- 6.45°	M- 21.81° B- 5.68°	M- 19.37° B- 5.08°	M- 17.42° B- 4.59°
20°	M- 43.22° B- 14.00°	M- 34.32° B- 11.60°	M- 28.48° B- 9.85°	M- 24.35° B- 8.53°	M- 21.27° B- 7.52°	M- 18.88° B- 6.72°	M- 16.98° B- 6.07°
25°	M- 42.19° B- 17.39°	M- 33.36° B- 14.38°	M- 27.62° B- 12.20°	M- 23.56° B- 10.57°	M- 20.58° B- 9.31°	M- 18.26° B- 8.31°	M- 16.41° B- 7.50°
30°	M- 40.89° B- 20.70°	M- 32.18° B- 17.09°	M- 26.57° B- 14.48°	M- 22.64° B- 12.53°	M- 19.73° B- 11.03°	M- 17.50° B- 9.85°	M- 15.72° B- 8.89°
35°	M- 39.32° B- 23.93°	M- 30.76° B- 19.70°	M- 25.31° B- 16.67°	M- 21.53° B- 14.41°	M- 18.74° B- 12.68°	M- 16.60° B- 11.31°	M- 14.90° B- 10.21°
40°	M- 37.45° B- 27.03°	M- 29.10° B- 22.20°	M- 23.86° B- 18.75°	M- 20.25° B- 16.19°	M- 17.60° B- 14.24°	M- 15.58° B- 12.70°	M- 13.98° B- 11.46°
45°	M- 35.26° B- 30.00°	M- 27.19° B- 24.56°	M- 22.21° B- 20.70°	M- 18.80° B- 17.87°	M- 16.32° B- 15.70°	M- 14.43° B- 14.00°	M- 12.94° B- 12.62°
50°	M- 32.73° B- 32.80°	M- 25.03° B- 26.76°	M- 20.36° B- 22.52°	M- 17.20° B- 19.41°	M- 14.91° B- 17.05°	M- 13.17° B- 15.19°	M- 11.80° B- 13.69°
55°	M- 29.84° B- 35.40°	M- 22.62° B- 28.78°	M- 18.32° B- 24.18°	M- 15.44° B- 20.82°	M- 13.36° B- 18.27°	M- 11.79° B- 16.27°	M- 10.56° B- 14.66°
60°	M- 26.57° B- 37.76°	M- 19.96° B- 30.60°	M- 16.10° B- 25.66°	M- 13.54° B- 22.07°	M- 11.70° B- 19.35°	M- 10.31° B- 17.23°	M- 9.23° B- 15.52°
65°	M- 22.91° B- 39.86°	M- 17.07° B- 32.19°	M- 13.71° B- 26.95°	M- 11.50° B- 23.16°	M- 9.93° B- 20.29°	M- 8.74° B- 18.06°	M- 7.82° B- 16.26°
70°	M- 18.88° B- 41.64°	M- 13.95° B- 33.53°	M- 11.17° B- 28.02°	M- 9.35° B- 24.06°	M- 8.06° B- 21.08°	M- 7.10° B- 18.75°	M- 6.34° B- 16.88°
75°	M- 14.51° B- 43.08°	M- 10.65° B- 34.59°	M- 8.50° B- 28.88°	M- 7.10° B- 24.78°	M- 6.12° B- 21.69°	M- 5.38° B- 19.29°	M- 4.81° B- 17.37°
80°	M- 9.85° B- 44.14°	M- 7.19° B- 35.37°	M- 5.73° B- 29.50°	M- 4.78° B- 25.30°	M- 4.11° B- 22.14°	M- 3.62° B- 19.68°	M- 3.23° B- 17.72°
85°	M- 4.98° B- 44.78°	M- 3.62° B- 35.84°	M- 2.88° B- 29.87°	M- 2.40° B- 25.61°	M- 2.07° B- 22.41°	M- 1.82° B- 19.92°	M- 1.62° B- 17.93°
90°	M- 0.00° B- 45.00°	M- 0.00° B- 36.00°	M- 0.00° B- 30.00°	M- 0.00° B- 25.71°	M- 0.00° B- 22.50°	M- 0.00° B- 20.00°	M- 0.00° B- 18.00°

Each B (Bevel) and M (Miter) Setting is Given to the Closest 0.005°.

### COMPOUND-ANGLE SETTINGS FOR POPULAR STRUCTURES

# OPERATION

## CUTTING CROWN MOLDING

The following chart illustrates the miter and bevel angle settings of the miter saw for both 52°/38° and 45°/45° crown molding, when the angle between the walls run from 67° to 146°. With the crown molding laying flat, cut at the following angles:

WALL ANGLE	38° / 52° MITER / BEVEL	45°/45° MITER/BEVEL	WALL ANGLE	38°/52° MITER/BEVEL	45°/45° MITER/BEVEL
67	42.93/41.08	46.89/36.13	107	24.49/27.95	27.62/24.87
68	42.39/40.79	46.35/35.89	108	24.10/27.59	27.19/24.56
69	41.85/40.50	45.81/35.64	109	23.71/27.23	26.77/24.24
70	41.32/40.20	45.28/35.40	110	23.32/26.87	26.34/23.93
71	40.79/39.90	44.75/35.15	111	22.93/26.51	25.92/23.61
72	40.28/39.61	44.22/34.89	112	22.55/26.15	25.50/23.29
73	39.76/39.30	43.70/34.64	113	22.17/25.78	25.08/22.97
74	39.25/39.00	43.18/34.38	114	21.79/25.42	24.66/22.65
75	38.74/38.69	42.66/34.12	115	21.42/25.05	24.25/22.33
76	38.24/38.39	42.15/33.85	116	21.04/24.68	23.84/22.01
77	37.74/38.08	41.64/33.60	117	20.67/24.31	23.43/21.68
78	37.24/37.76	41.13/33.33	118	20.30/23.94	23.02/21.36
79	36.75/37.45	40.62/33.07	119	19.93/23.57	22.61/21.03
80	36.27/37.13	40.12/32.80	120	19.57/23.20	22.21/20.70
81	35.79/36.81	39.62/32.53	121	19.20/22.83	21.80/20.38
82	35.31/36.49	39.13/32.25	122	18.84/22.46	21.40/20.05
83	34.83/36.17	38.63/31.98	123	18.48/22.09	21.00/19.72
84	34.36/35.85	38.14/31.70	124	18.13/21.71	20.61/19.39
85	33.90/35.52	37.66/31.42	125	17.77/21.34	20.21/19.06
86	33.43/35.19	37.17/31.14	126	17.42/20.96	19.81/18.72
87	32.97/34.86	36.69/30.86	127	17.06/20.59	19.42/18.39
88	32.52/34.53	36.21/30.57	128	16.71/20.21	19.03/18.06
89	32.07/34.20	35.74/30.29	129	16.37/19.83	18.64/17.72
90	31.62/33.85	35.26/30.00	130	16.02/19.45	18.25/17.39
91	31.17/33.53	34.79/29.71	131	15.67/19.07	17.86/17.05
92	30.73/33.19	34.33/29.42	132	15.33/18.69	17.48/16.71
93	30.30/32.85	33.86/29.13	133	14.99/18.31	17.09/16.38
94	29.86/32.51	33.40/28.83	134	14.65/17.93	16.71/16.04
95	29.43/32.17	32.94/28.54	135	14.30/17.55	16.32/15.70
96	29.00/31.82	32.48/28.24	136	13.97/17.17	15.94/15.36
97	28.58/31.48	32.02/27.94	137	13.63/16.79	15.56/15.02
98	28.16/31.13	31.58/27.64	138	13.30/16.40	15.19/14.68
99	27.74/30.78	31.13/27.34	139	12.96/16.02	14.81/14.34
100	27.32/30.43	30.68/27.03	140	12.63/15.64	14.43/14.00
101	26.91/30.08	30.24/26.73	141	12.30/15.25	14.06/13.65
102	26.50/29.73	29.80/26.42	142	11.97/14.87	13.68/13.31
103	26.09/29.38	29.36/26.12	143	11.64/14.48	13.31/12.97
104	25.69/29.02	28.92/25.81	144	11.31/14.09	12.94/12.62
105	25.29/28.67	28.48/25.50	145	10.99/13.71	12.57/12.28
106	24.89/28.31	28.05/25.19	146	10.66/13.32	12.20/11.93



# OPERATION

## CUTTING CROWN MOLDING

Your compound miter saw does an excellent job of cutting crown molding. In general, compound miter saws do a better job of cutting crown molding than any other tool made.

In order to fit properly, crown molding must be compound mitered with extreme accuracy.

The two contact surfaces on a piece of crown molding that fit flat against the ceiling and the wall of a room are at angles that, when added together, equal exactly 90°. Most crown molding has a top rear angle (the section that fits flat against the ceiling) of 52° and a bottom rear angle (the section that fits flat against the wall) of 38°.

## LAYING MOLDING FLAT ON THE MITER TABLE

See Figure 34.

To use this method for accurately cutting crown molding for a 90° inside or outside corner, lay the molding with its broad back surface flat on the miter table and against the fence.

When setting the bevel and miter angles for compound miters, remember that the settings are interdependent; changing one angle changes the other angle as well.

Keep in mind that the angles for crown moldings are very precise and difficult to set. Since it is very easy for these angles to shift, all settings should first be tested on scrap molding. Also most walls do not have angles of exactly 90°, therefore, you will need to fine tune your settings.

When cutting crown molding by this method the bevel angle should be set at 33.85°. The miter angle should be set at 31.6° either right or left, depending on the desired cut for the application. See the chart below for correct angle settings and correct positioning of crown molding on miter table.

The settings in the chart below can be used for cutting All Standard (U.S.) crown molding with 52° and 38° angles. The crown molding is placed flat on the miter table using the compound features of your miter saw.

Bevel Angle Setting	Type of Cut
33.85°	Left side, inside corner 1. Top edge of molding against fence 2. Miter table set right 31.6° 3. Save left end of cut
33.85°	Right side, inside corner 1. Bottom edge of molding against fence 2. Miter table set left 31.6° 3. Save left end of cut
33.85°	Left side, outside corner 1. Bottom edge of molding against fence 2. Miter table set left 31.6° 3. Save right end of cut
33.85°	Right side, outside corner 1. Top edge of molding against fence 2. Miter table set right 31.6° 3. Save right end of cut

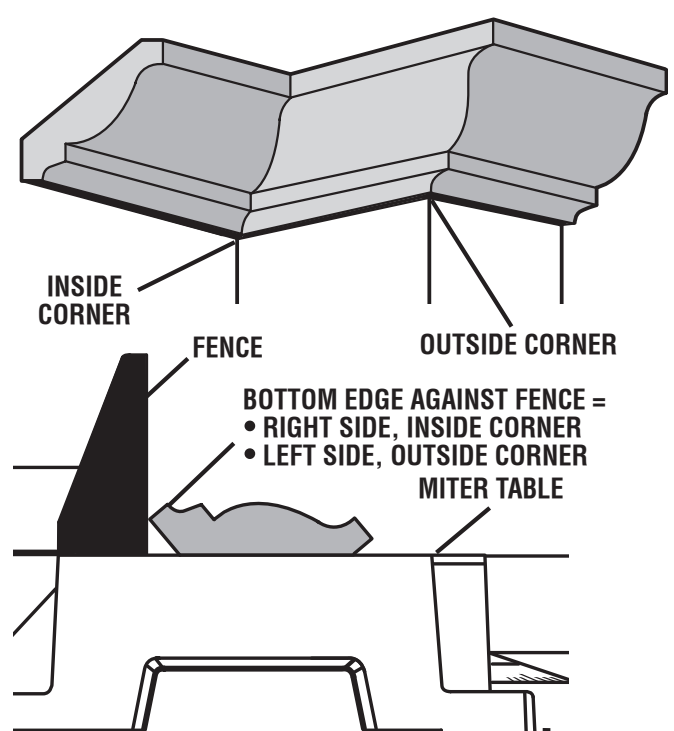
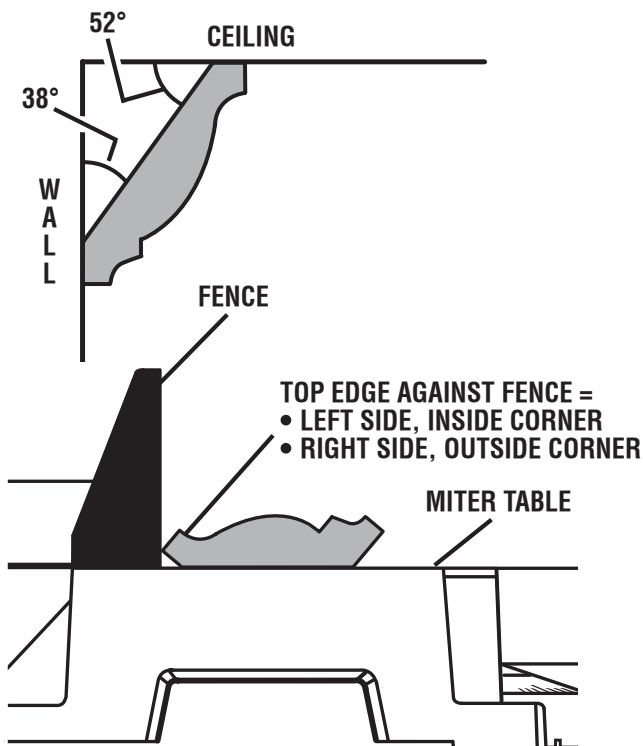

CROWN MOLDING FLAT ON MITER TABLE

Fig. 34

# OPERATION

Bevel Angle Setting	Type of Cut
0°	Left side, inside corner 1. Top edge of molding against fence 2. Miter table set right 45° 3. Save left end of cut
0°	Right side, inside corner 1. Bottom edge of molding against fence 2. Miter table set left 45° 3. Save left end of cut
0°	Left side, outside corner 1. Bottom edge of molding against fence 2. Miter table set left 45° 3. Save right end of cut
0°	Right side, outside corner 1. Top edge of molding against fence 2. Miter table set right 45° 3. Save right end of cut

## CUTTING WARPED MATERIAL

See Figures 35 - 36.

When cutting warped material, always make sure it is positioned on the miter table with the convex side against the fence as shown in figure 36.

If the warped material is positioned the wrong way as shown in figure 35, it will pinch the blade near the completion of the cut.

### WARNING:

To avoid a kickback and to avoid serious personal injury, never position the concave edge of bowed or warped material against the fence.

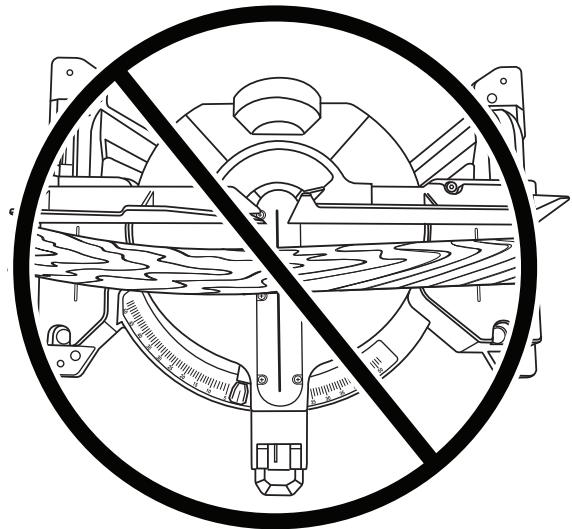

**WRONG**

Fig. 35

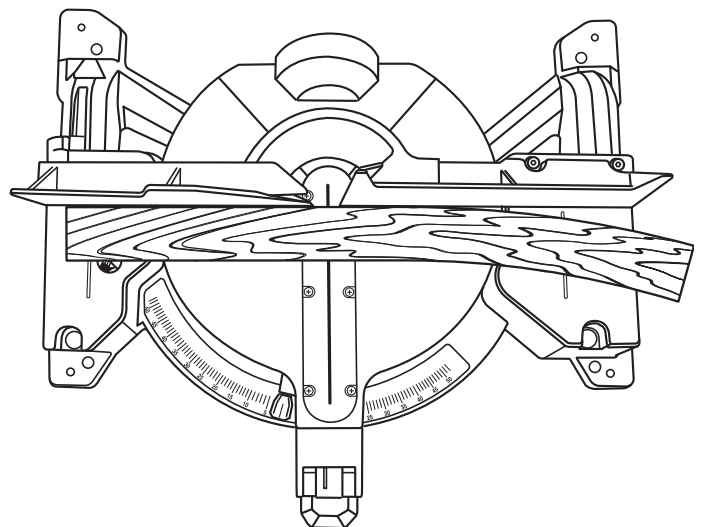

**RIGHT**

Fig. 36

# ADJUSTMENTS

## **⚠ WARNING:**

Before performing any adjustment, make sure the tool is unplugged from the power supply. Failure to heed this warning could result in serious personal injury.

## **TO ADJUST THE LASER GUIDE**

See Figure 37.

**NOTE:** Avoid direct eye exposure when using the laser guide.

- Set both the bevel angle and the miter table at 0°.
- Use the work clamp or a C-clamp to secure a piece of scrap wood.
- Plug the saw into the power source and make a slight cut to score the wood.
- Raise the saw arm and unplug the saw.
- Lift and hold the lower blade guard.
- Rotate the blade by hand until you can push and hold the laser button and the laser mark is near the center of the workpiece as shown in figure 37.
- To adjust the laser, turn the adjustment screw counter-clockwise or clockwise using the hex key (1/16 in.) provided.

**NOTE:** When properly aligned, the laser mark should be on the left edge of the kerf.

- Once aligned, remove and store the hex key (1/16 in.), and lower the blade guard.

**NOTE:** Always make practice cuts on scrap wood before cutting through your workpiece.

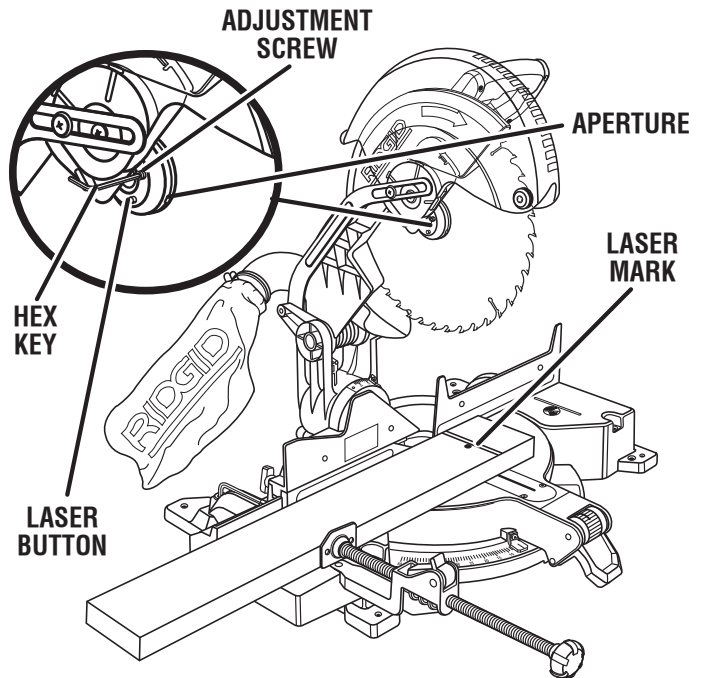

Fig. 37

# MAINTENANCE

## **WARNING:**

When servicing, use only identical replacement parts. Use of any other part may create a hazard or cause product damage.

## **WARNING:**

Always wear safety goggles or safety glasses with side shields during power tool operation or when blowing dust. If operation is dusty, also wear a dust mask.

## GENERAL MAINTENANCE

Avoid using solvents when cleaning plastic parts. Most plastics are susceptible to damage from various types of commercial solvents and may be damaged by their use. Use clean cloths to remove dirt, carbon dust, etc.

## **WARNING:**

Do not at any time let brake fluids, gasoline, petroleum-based products, penetrating oils, etc., come in contact with plastic parts. They contain chemicals that can damage, weaken, or destroy plastic.

## LUBRICATION

All of the bearings in this tool are lubricated with a sufficient amount of high grade lubricant for the life of the unit under normal operating conditions. Therefore, no further lubrication is required.

## **WARNING:**

To ensure safety and reliability, all repairs should be performed by a qualified service technician at an authorized service center to avoid risk of personal injury.

Some areas will require infrequent lubrications. You will need to apply:

- Automotive oil directly to the slide bars.
- Light oil or a pressurized light spray oil to the arm pivot shaft.
- Light oil or a pressurized light spray oil to the torsion spring.

## BRUSH REPLACEMENT

See Figure 38.

The saw has externally accessible brush assemblies that should be periodically checked for wear.

**Proceed as follows when replacement is required:**

- Unplug the saw.

## **WARNING:**

Failure to unplug the saw could result in accidental starting causing serious injury.

- Remove brush cap with a screwdriver. Brush assembly is spring loaded and will pop out when you remove brush cap.
- Remove brush assembly.
- Check for wear. Replace both brushes when either has less than 1/4 in. length of carbon remaining. **Do not** replace one side without replacing the other.
- Reassemble using new brush assemblies. Make sure curvature of brush matches curvature of motor and that brush moves freely in brush tube.
- Make sure brush cap is oriented correctly (straight) and replace.
- Tighten brush cap securely. **Do not** overtighten.

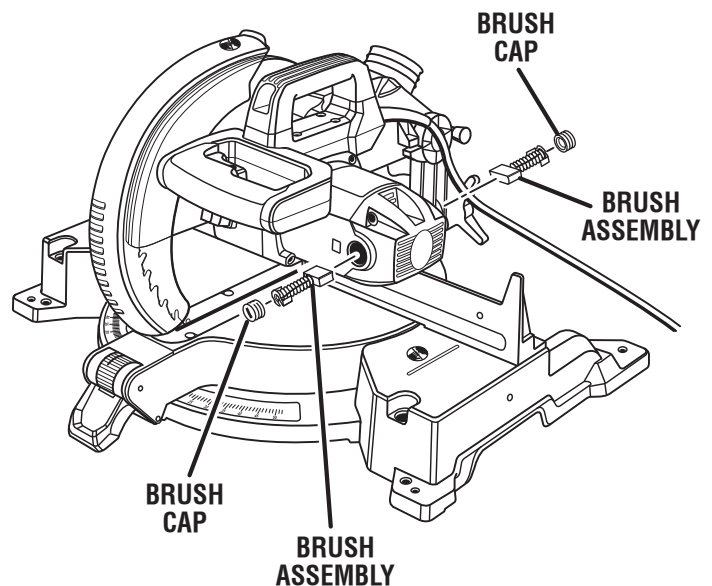

Fig. 38

# MAINTENANCE

## CHANGING THE BATTERIES IN THE LASER

See Figure 39.

- Unplug the saw.
- Rotate and hold lower blade guard up.
- Using the hex key (1/16 in.) provided, loosen and remove the screw from the battery compartment then separate the cover from the laser guide.
- Lower the blade guard.
- Remove the three button cell batteries.

**NOTE:** Replace the batteries with button cell batteries that have a rating of 1.5 volt and 100 mAh (milliampere hour) minimum (number 76 series or equivalent).

When replacing the batteries, the laser guide should be thoroughly cleaned. Use a soft paintbrush, or similar device, to remove all sawdust and debris.

- After cleaning the laser guide and replacing batteries, secure battery compartment to laser guide using the screw. Tighten screw securely.

### **CAUTION:**

Use of controls or adjustments or performance of procedures other than those specified herein may result in hazardous radiation exposure.

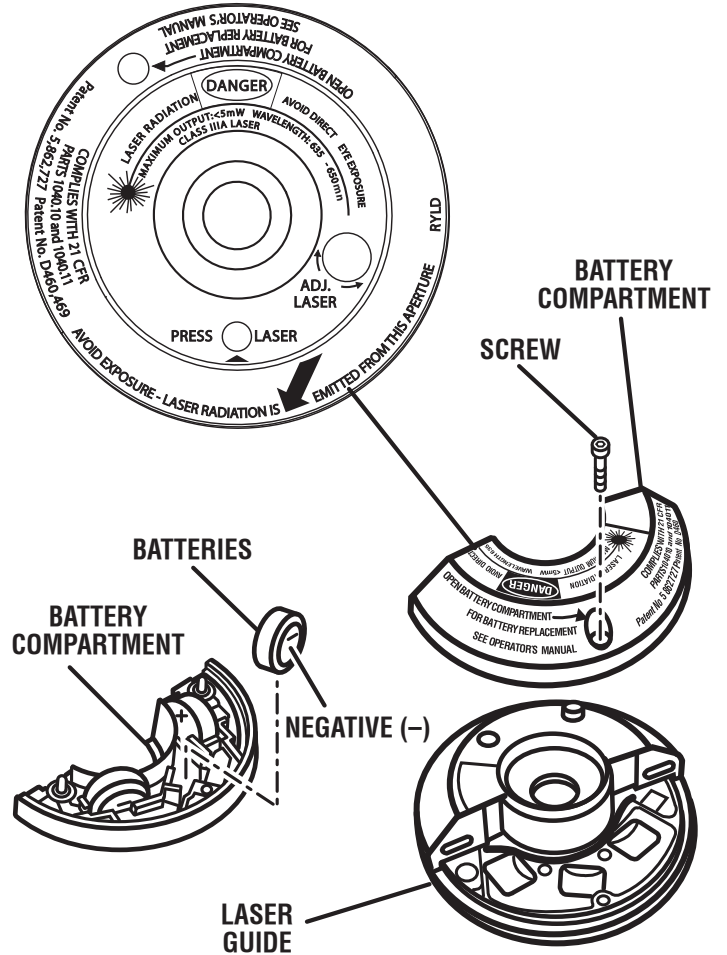

Fig. 39

# WARRANTY

---

## RIDGID® HAND HELD AND STATIONARY POWER TOOL 3 YEAR LIMITED SERVICE WARRANTY

Proof of purchase must be presented when requesting warranty service.

Limited to RIDGID® hand held and stationary power tools purchased 2/1/04 and after. This product is manufactured by One World Technologies, Inc. The trademark is licensed from RIDGID®, Inc. All warranty communications should be directed to One World Technologies, Inc., attn: RIDGID® Hand Held and Stationary Power Tool Technical Service at (toll free) 1-866-539-1710.

### 90-DAY SATISFACTION GUARANTEE POLICY

During the first 90 days after the date of purchase, if you are dissatisfied with the performance of this RIDGID® Hand Held and Stationary Power Tool for any reason you may return the tool to the dealer from which it was purchased for a full refund or exchange. To receive a replacement tool you must present proof of purchase and return all original equipment packaged with the original product. The replacement tool will be covered by the limited warranty for the balance of the 3 YEAR service warranty period.

### WHAT IS COVERED UNDER THE 3 YEAR LIMITED SERVICE WARRANTY

This warranty on RIDGID® Hand Held and Stationary Power Tools covers all defects in workmanship or materials and normal wear items such as brushes, chucks, motors, switches, cords, gears and even cordless batteries in this RIDGID® tool for three years following the purchase date of the tool. Warranties for other RIDGID® products may vary.

### HOW TO OBTAIN SERVICE

To obtain service for this RIDGID® tool you must return it; freight prepaid, or take it in to an authorized service center for RIDGID® branded hand held and stationary power tools. You may obtain the location of the authorized service center nearest you by calling (toll free) 1-866-539-1710 or by logging on to the RIDGID® website at [www.ridgid.com](http://www.ridgid.com). When requesting warranty service, you must present the original dated sales receipt. The authorized service center will repair any faulty workmanship, and either repair or replace any part covered under the warranty, at our option, at no charge to you.

### WHAT IS NOT COVERED

This warranty applies only to the original purchaser at retail and may not be transferred. This warranty only covers defects arising under normal usage and does not cover any malfunction, failure or defect resulting from misuse, abuse, neglect, alteration, modification or repair by other than an authorized service center for RIDGID® branded hand held and stationary power tools. Consumable accessories provided with the tool such as, but not limited to, blades, bits and sand paper are not covered.

**RIDGID®, INC. AND ONE WORLD TECHNOLOGIES, INC. MAKE NO WARRANTIES, REPRESENTATIONS OR PROMISES AS TO THE QUALITY OR PERFORMANCE OF ITS POWER TOOLS OTHER THAN THOSE SPECIFICALLY STATED IN THIS WARRANTY.**

### ADDITIONAL LIMITATIONS

To the extent permitted by applicable law, all implied warranties, including warranties of MERCHANTABILITY or FITNESS FOR A PARTICULAR PURPOSE, are disclaimed. Any implied warranties, including warranties of merchantability or fitness for a particular purpose, that cannot be disclaimed under state law are limited to three years from the date of purchase. One World Technologies, Inc. and RIDGID®, Inc. are not responsible for direct, indirect, incidental or consequential damages. Some states do not allow limitations on how long an implied warranty lasts and/or do not allow the exclusion or limitation of incidental or consequential damages, so the above limitations may not apply to you. This warranty gives you specific legal rights, and you may also have other rights which vary from state to state.

---

**One World Technologies, Inc.**

P.O. Box 35, Hwy. 8

Pickens, SC 29671

---

