

# *Signature bath*

## Walk-In Series Installation Guide



(Shown here with faucets which are not included)

***Certified***



## **IMPORTANT SAFETY INSTRUCTIONS**

**PLEASE READ AND FOLLOW ALL INSTRUCTIONS PROVIDED CAREFULLY**

**Install to allow adequate access for maintenance and the possibility of future servicing.**

**"An equipment grounding terminal is provided in the field wiring compartment. To reduce the risk of electric shock, this terminal must be connected to the grounding means provided in the electric supply panel with a conductor equivalent in size to the circuit conductors supplying this equipment"**

**FOR INDOOR USE ONLY.**

**INSTALL IN ACCORDANCE WITH THE MANUFACTURER'S INSTALLATION INSTRUCTIONS.**

**USE SUPPLY WIRES SUITABLE FOR 30A OC.**

**CONNECT ONLY TO A CIRCUIT PROTECTED BY A CLASS A GROUND FAULT CIRCUIT INTERRUPTER.**

**CONNECT ONLY TO A BRANCH CIRCUIT PROTECTED BY AN OVERCURRENT PROTECTION DEVICE RATED NOT MORE THAN 30 A.**

**BONDING LUGS USE COPPER CONDUCTORS ONLY.**

***SAVE THESE INSTRUCTIONS***

**WARNING – When using electrical products, basic precautions should always be followed, including the following:**

**CAUTION: RISK OF ELECTRIC SHOCK, DISCONNECT ELECTRIC POWER BEFORE SERVICING**

- 1. DANGER: RISK OF ELECTRIC SHOCK. Connect only to a circuit protected by a ground-fault circuit-interrupter. Grounding is required. The unit should be installed by a qualified service representative and grounded.**
- 2. Never run any cords through or near heaters, pump bodies or any device designed to increase water temperatures or produce heat during normal operations.**
- 3. Be sure to install proper bracing and supports to handle the weight of these units when full which can exceed 1200lbs**

**This manual has been provided to aid the installer during the installation process. It is highly recommended that your walk-in bathtub be installed by a properly licensed plumber or contractor. Failure to do so may void your warranty.**

**WARNING: RISK OF ACCIDENTAL INJURY OR DROWNING, CHILDREN SHOULD NOT USE HYDROMASSAGE BATHTUB WITHOUT ADULT SUPERVISION.**

**WARNING: RISK OF ACCIDENTAL INJURY OR DROWNING, DO NOT USE HYDROMASSAGE BATHTUB UNLESS ALL SUCTION GUARDS ARE INSTALLED TO PREVENT BODY AND HAIR ENTRAPMENT.**

**WARNING: TO AVOID INJURY, EXERCISE CARE WHEN ENTERING OR EXITING THE HYDROMASSAGE BATHTUB.**

**WARNING: RISK OF ACCIDENTAL INJURY OR DROWNING, DO NOT USE DRUGS OR ALCOHOL BEFORE OR DURING THE USE OF A HYDROMASSAGE BATHTUB EQUIPPED WITH HEATER TO AVOID UNCONSCIOUSNESS AND POSSIBLE DROWNING.**

**WARNING: RISK OF FETAL INJURY, PREGNANT OR POSSIBLY PREGNANT WOMEN SHOULD CONSULT A PHYSICIAN BEFORE USING A HYDROMASSAGE BATHTUB EQUIPPED WITH HEATER.**

**WARNING: RISK OF HYPERTHERMIA AND POSSIBLE DROWNING, DO NOT USE A HYDROMASSAGE BATHTUB EQUIPPED WITH HEATER IMMEDIATELY FOLLOWING STRENUOUS EXERCISE.**

**CAUTION: TEST THE GROUND FAULT CIRCUIT INTERRUPTER PROTECTING THIS APPLIANCE PERIODICALLY IN ACCORDANCE WITH THE MANUFACTURER'S INSTRUCTIONS.**

**WARNING: RISK OF HYPERTHERMIA AND POSSIBLE DROWNING, WATER TEMPERATURE IN EXCESS OF 38°C MAY BE INJURIOUS TO YOUR HEALTH. CHECK AND ADJUST WATER TEMPERATURE BEFORE USE.**

**WARNING: RISK OF HYPERTHERMIA, PEOPLE USING MEDICATIONS AND/OR HAVING AN ADVERSE MEDICAL HISTORY SHOULD CONSULT A PHYSICIAN BEFORE USING A HYDROMASSAGE BATHTUB EQUIPPED WITH HEATER.**

**WARNING: RISK OF ELECTRIC SHOCK, DO NOT PERMIT ELECTRIC APPLIANCES (SUCH AS A HAIR DRYER, LAMP, TELEPHONE, RADIO, OR TELEVISION) WITHIN 1.5 M OF THIS HYDROMASSAGE BATHTUB.**

## **Important Notes**

1. **Never** lift a whirlpool bathtub by the pipes! By doing this you can cause severe damage to the whirlpool system. Always lift the unit by the frame to avoid the risk of any damage to the unit or the whirlpool system.
2. Before installation cover all of the jets and suction to minimize the chance of debris falling into them and creating a blockage.
3. Cover the door drain located at the bottom of the door opening with tape to avoid blocking it with debris.
4. **Never** use the door as a handle for lifting, or a seat during installation.
5. be sure to cover the acrylic surface while setting tile and/or painting to avoid damaging the high gloss finish.
6. **Do not** dry wipe the unit during the cleaning process, always vacuum the tub out prior to using mild soap and water and a fresh soft cloth to clean.
7. \*It is **mandatory** that the floor be properly supported prior to use. Mortar mix is recommended. Any floor that has not been properly supported will not be covered under the manufactures structural warranty as implied.

**\*Important: Be sure to uncover all holes and blow out the door drain with compressed air before filling and testing after the installation has been completed!**

**Plumbers please note that the following parts will be needed to connect the door drain to the main drain assembly.**

1. 1 1/2 x 1 1/2 x 1/2 fipt Fitting Lasco part #402-409
2. Watts A193B Barb fitting

**Please view the diagram on page 6 for details.**

## ELECTRICAL CONNECTIONS



**DANGER:** Risk of severe injury from electric shock or death by electrocution. This bath must be connected directly to a dedicated 120V 20 amp supply circuit that is protected by a Ground Fault Circuit Interrupter (GFCI) installed by a qualified, licensed electrician in accordance with national electric and local codes and the GFCI manufacturer's instructions. The GFCI should be tested regularly. To test the GFCI, push the "TEST" button. The GFCI should interrupt the power supply to the outlet. Push the "RESET" button and the power should be restored. If the GFCI fails to operate in this manner, it is defective. If the GFCI interrupts power without pressing the "TEST" button, a ground current is flowing indicating the possibility of electric shock exists. DO NOT USE. Disconnect the unit and have the problem corrected by a qualified licensed electrician before using.

The GFCI is not included with the bath. The circuit must be a (3) three-wire circuit hard wired from the main power supply. Install the outlet on the stud wall at least 4" above the floor. Your bath is equipped with a 36" cord with a grounded plug on the pump. Do not remove the grounding pin or alter the cord in any way.

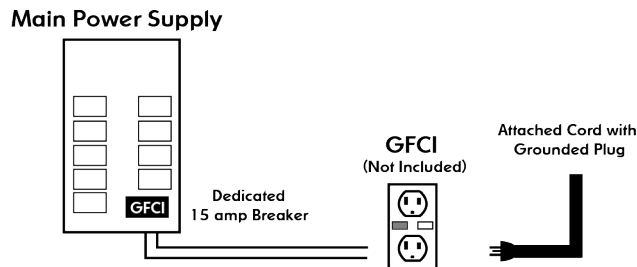

**Important:** Unauthorized modification may cause unsafe operation and poor performance. Moving components or making modifications may adversely affect performance and make operation unsafe. Signature Bath shall not be liable under its warranty of otherwise for personal injury or damage that is the result of unauthorized modification.

**Important:** Risk of overheating. Cord must be plugged directly into the GFCI. Do not use an extension cord or surge protector.

**Important:** Operating the pump without enough water in the bath can cause leaking and permanent damage to the pump.

# Disclaimer:

Signature Bath is not responsible for damage when holes are drilled to install faucets. The information provided below is for general reference only and the actual measurements are for the installer to determine prior to drilling any holes in the tub. It is our suggestion that the installer should drill holes in scrap wood and test fit faucet parts prior to drilling into the tub. Please mark the tub prior to drilling and test fit the escutcheon bearing in mind that tile will be added to the faucet deck during the final installation trim process. So please allow proper room for the tile.

## General Faucet Guide (Use at your own risk)

**\*\*Use Extreme Caution\*\***

Never drill in the center of the faucet pad where the overflow passes through!!!

\*Note: Whenever drilling holes use a piece of scrap wood to test your hole size and adjust accordingly if necessary!!!

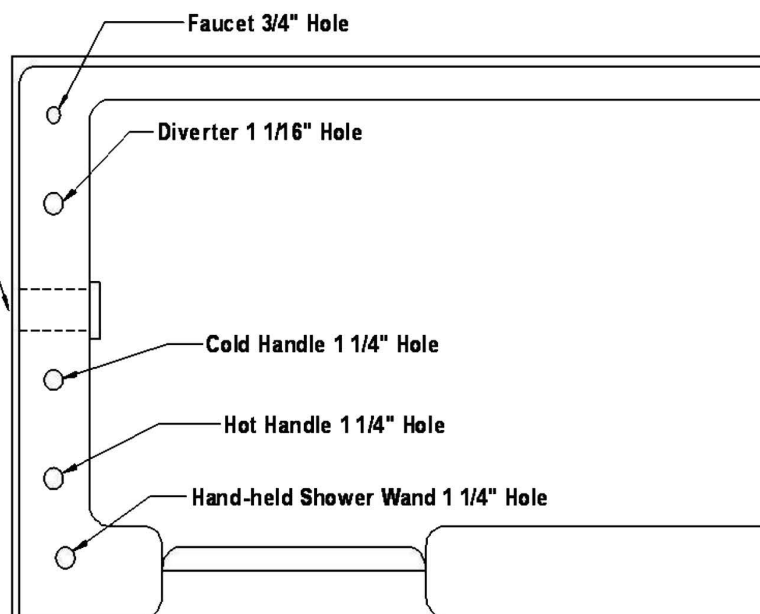

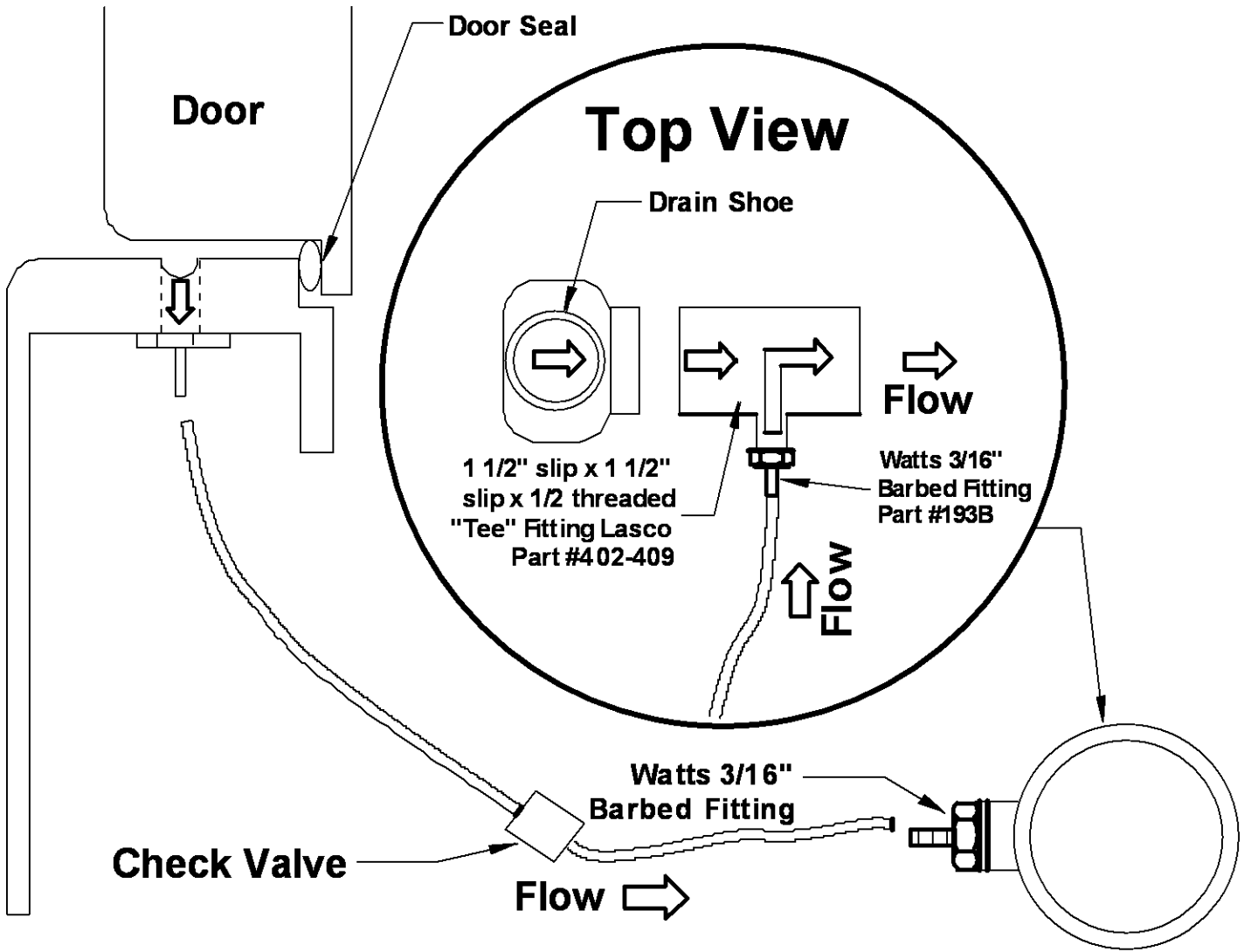

# Front View

## Door Drain Assembly



**After removing your old tub or shower, take a level and check to be sure all the walls are level. Next remove any debris and check for any obstruction that may interfere with your installation.**



**Now you can bring in your new unit and begin to install it. Make sure that all sides fit to the walls and begin leveling the unit.**



**Use the five leveling legs provided to adjust height and achieve uniform leveling of the tub. Loosen the top (locking) nut by turning counter-clockwise, then loosen the bottom (adjusting) nut and move up or down according to leveling demands. After achieving the proper adjustment tighten the lock nut to secure the leveling leg.**

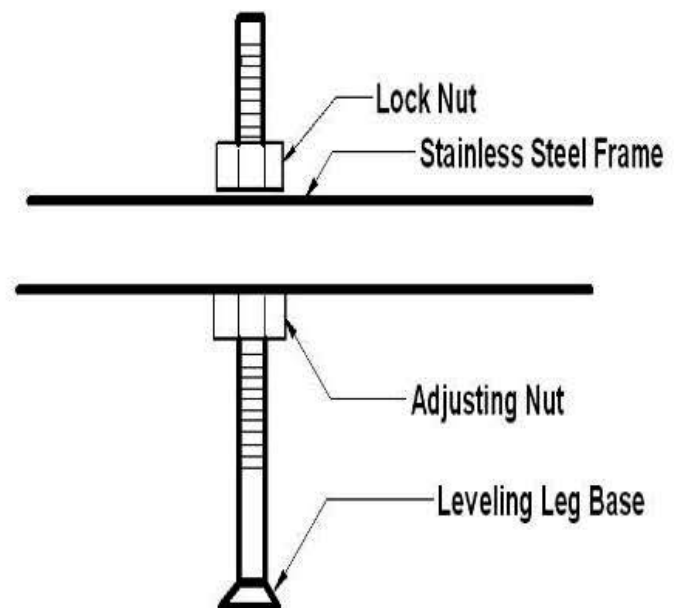

**After properly leveling the unit, your plumber is now ready to install your plumbing. After the plumbing has been installed, it is imperative that you check for any leaks at this point before proceeding any further.**



**Depending on the size unit that you choose, there may or may not be additional space left which in most cases can be easily converted to a handy shelf area to hold soap, shampoo etc..., as shown here during the framing stages.**



**Be sure to use waterproof materials on the walls surrounding your bathtub such as cement board shown here to avoid any future mold issues.**



You are now at the point which the walls can be covered with your choice of materials. We chose tile. Not matter what you use please pay close attention to detail, to ensure that your AquaEze Walk-in bathtub will retain it's elegant appeal.



The pictures below depict the correct and incorrect alignment of the tile flange and cement board. The picture labeled incorrect shows that the cement board is not lined up properly with the integral tile flange, leaving an air gap. The picture labeled correct indicates that the cement board has been properly installed ensuring a perfect tile angle.

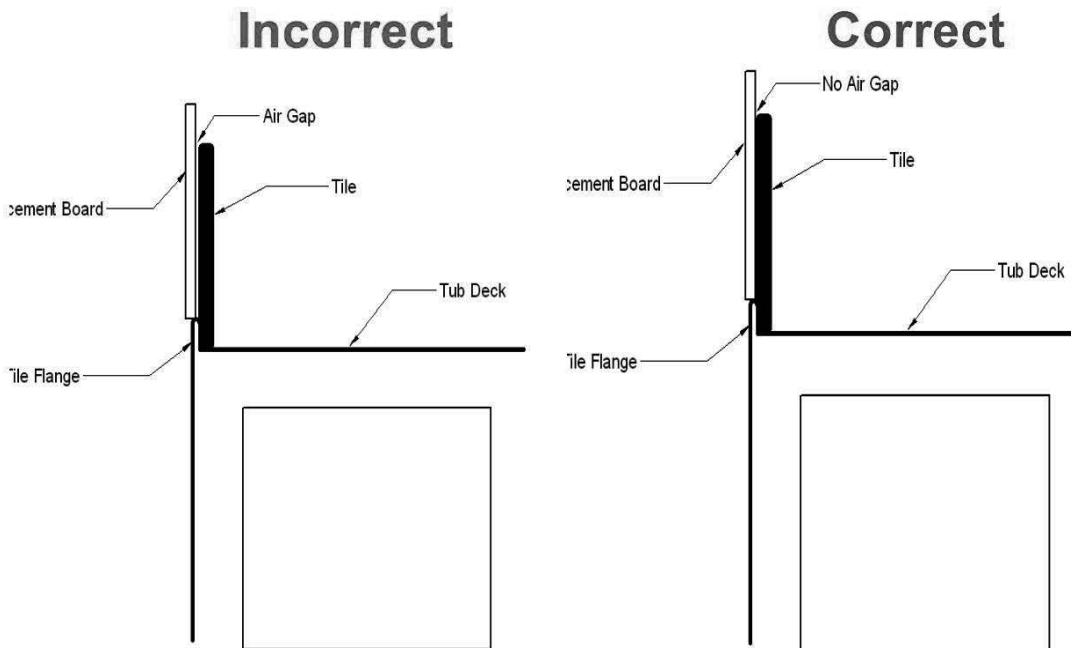

## Drain Stopper Adjustment

Step 1. Lift the drain stopper out of the drain.

Step2. Locate the lock nut as shown in figure 1

Step 3. Loosen the lock nut as shown in figure 2

Step 4. Turn the adjusting bolt in or out to the desired height.

Step 5. Tighten the lock nut.

Step6. Insert the stopper back into the drain.

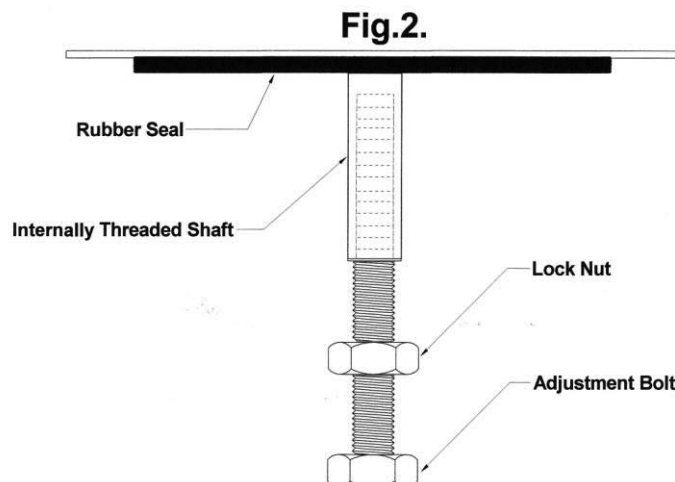
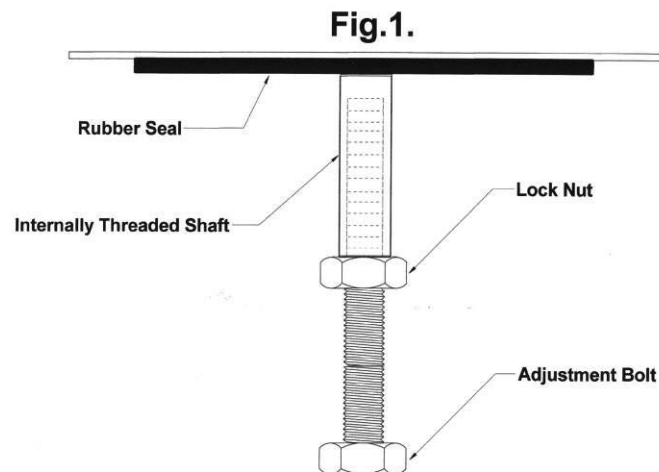

## **SIGNATURE BATH MANUFACTURER'S LIMITED WARRANTY for Walk-In Series Baths**

### **WARRANTY COVERAGE**

Throughout this document, Signature Bath shall be referred to as the "MANUFACTURER". The following expressed limited lifetime warranty is given to the original consumer of a Luxury or Luxury Plus Series Signature Bath purchased for personal or single family residential use. Any commercial applications are excluded from all warranties. Repair or replacement of the bath or any components is at the MANUFACTURER'S discretion in accordance with the following terms and conditions.

### **10 YEAR WARRANTY FOR BATH SURFACE**

The MANUFACTURER warrants the tub shell against fading and cracking due to defects in materials and workmanship for a period of TEN (10) years from the date of purchase. This warranty is for the parts only and excludes labor charges.

### **5 YEAR LIMITED WARRANTY FOR FACTORY INSTALLED PLUMBING COMPONENTS**

The MANUFACTURER warrants the factory installed jet internals, waterfall, and plumbing components against failure due to defects in materials and workmanship for a period of FIVE (5) years from the date of purchase. This warranty is for the parts only and excludes labor charges.

### **3 YEAR LIMITED WARRANTY FOR BATHS EQUIPPED WITH A FACTORY INSTALLED PUMP AND/OR BLOWER**

The MANUFACTURER warrants the factory installed pump and/or blower against failure due to defects in materials and workmanship for a period of THREE (3) years from the date of purchase. This warranty is for the parts only and excludes labor charges.

### **1 YEAR LIMITED WARRANTY FOR BATHS EQUIPPED WITH FACTORY INSTALLED ELECTRONIC COMPONENTS**

The MANUFACTURER warrants factory installed electronic components, including in-line heater, lighting, and electronic controls against failure due to defects in materials and workmanship for a period of ONE (1) year from the date of purchase. This warranty is for the parts only and excludes labor charges.

### **1 YEAR LIMITED LABOR WARRANTY FOR ALL FACTORY INSTALLED COMPONENTS**

In baths equipped with factory installed components, all factory installed components including the pump, motor, blower, electronic and plumbing components are covered under the labor warranty against failure due to defects in materials and workmanship. Labor is described as the work completed by a technician. MANUFACTURER will be responsible for the costs associated with labor for all warranty repairs for ONE (1) Year from the original consumer's date of purchase, but not more than TWO (2) Years from the date of manufacture.

Replacement parts are subject to availability and may differ slightly from those originally supplied. The MANUFACTURER cannot guarantee parts currently in use will be available in the future. Changes in materials, parts or specifications are not valid reasons for product refusal or replacement under the warranty. Display models are excluded from this warranty. This warranty begins on the original consumer's date of purchase.

### **WARRANTY PROCEDURE**

The MANUFACTURER relies upon the consumer and technician to assist with filing of warranty claims and to help work toward customer satisfaction. To file a warranty claim, please call Signature Bath Customer Care at 844-894-6659 and be prepared to provide the following information when you call:

* Signature Bath Model	* Name & Address	* Serial Number	* Phone number
* Date of Purchase	* Dealer Name	* Thorough Description Problem	* Pictures of the Defect

Upon receipt of all of the requested information, Customer Care will evaluate the claim and determine how the claim will be resolved. If you have any questions concerning a claim, you should call Signature Bath Customer Care at 844-894-6659 for assistance.

Repairs will not be made without the pre-authorized consent of the MANUFACTURER. Consumers must notify the MANUFACTURER of any malfunction or defect within 10 days of discovery. The Manufacturer reserves the right to inspect the defect or malfunction, Repair or replacement is at the MANUFACTURER'S sole discretion. In all situations, a repair is considered the appropriate course of action. Technicians who perform inspections and/or repairs are not employees, representatives, or agents of the MANUFACTURER and as such, the MANUFACTURER is not bound by their words or actions. If the bath cannot be repaired, the consumer is responsible for all costs associated with the removal, delivery and installation of the replacement and will not be covered by the MANUFACTURER under any circumstance. It is the responsibility of the consumer to ensure the Bath is accessible for repairs. If parts are required for repair, MANUFACTURER is not responsible for the cost of shipping of parts under the terms of this warranty agreement. The MANUFACTURER is not responsible for delays caused by failure to submit all of the information in a timely manner.

### **RESPONSIBILITIES**

- The installer or consumer is responsible for knowing local code requirements and notifying the installer or consumer of those requirements at the time of purchase. The MANUFACTURER is not responsible for modifications or the costs to modify the Bath to obtain city, county or state code approval.
- The installer or building contractor acting on behalf of the consumer is responsible inspecting the Bath and ensuring it is free from defects or damage at the time of delivery. If a defect or damage is found, the unit cannot be installed. The MANUFACTURER is not responsible for failures or damage that could have been discovered, repaired or avoided if the Bath had been properly inspected and tested by filling with water prior to installation. Damage that occurs during installation is the responsibility of the installer or building contractor. Damage that occurs after installation is the responsibility of the consumer.
- Damage that occurs during transit is the responsibility of the carrier. The consumer or installer must remove the packing materials and inspect the Bath for damage at the time of delivery. If damage is discovered, delivery of the Bath must be refused and a replacement will be sent at no additional charge. The MANUFACTURER is not responsible for damage that should have been discovered during inspection at the time of delivery.
- Failure of the optional components and accessories is the sole responsibility of the original manufacturer except as provided in this warranty. Replacement parts are the responsibility of the original manufacturer.

### **LIMITATIONS**

The MANUFACTURER'S warranty does not cover defects, damage or failure caused by common carriers, installers, users or any other people, pets, rodents, without limitation from failure to exercise reasonable care, mishandling, negligence, improper installation, damage resulting from any modifications including modifications required to meet code, materials supplied by the installer or third parties, connections made by the installer, improper electrical connections, incorrect voltage, misuse, abuse, lack of required routine maintenance, operation at below minimum water level or incorrect water temperatures, use of abrasive or other harmful cleaners, failure to follow MANUFACTURER'S recommendations and instructions, Acts of God, such as lightning, flooding, earthquakes, tornadoes, etc.

The MANUFACTURER will not be responsible for incidental or consequential damages or losses (damage to floors, floor coverings, ceilings, walls, loss of use, clean up) from any cause including its own negligence with respect to or resulting from parts damaged by exposure to pool or spa chemicals, hard water, optional equipment not made by the MANUFACTURER, Baths used on display, or defects that should have been prior to installation. This warranty does not include labor, transportation, any costs associated with removal, delivery and installation of a replacement Bath, costs associated with obtaining access to make repairs, loss of use damages including, sales, profit or any sales advantage of any kind under any circumstances. Warranty coverage is void if Bath is not water tested or inspected prior to final installation. Warranty coverage is terminated if any addition, deletion or modification of any kind has been made to the Bath or any component.

### **EXCLUSION OF IMPLIED WARRANTIES**

No one has the authorization to add, take away, or make any promise of performance, fitness for a particular purpose, imply warranties of merchantability, or make any representation not included in the MANUFACTURER'S warranties that accompany each Signature Bath. There are no additional warranties, express or implied, which extend beyond the terms of this written warranty.

NOTICE: This warranty gives you specific legal rights, and you may also have other rights which vary from state to state. This warranty stipulates, and purchaser agrees, that any disputes that arise shall be governed by the laws in the State of Tennessee which is the appropriate forum and venue for resolution. There are no warranties applicable to Signature Bath products except as expressly stated herein or as implied by applicable state and federal laws. The MANUFACTURER will not be responsible for any statements or representations made in any form that go beyond, are broader than, or inconsistent with any authorized literature or specifications furnished by the MANUFACTURER. Some states do not allow limitations on how long an implied warranty lasts, or the exclusion of limitation of incidental or consequential damages, so the above limitations may not apply to you.

Thank you for purchasing this Signature Bath. We know you'll enjoy the relaxation, comfort and security of your walk-in bath for many years to come.

### **Our Commitment to Quality**

Signature Baths are hand-crafted using the finest parts and materials available. Upon completion of the manufacturing and assembly process, they are subjected to strict quality control testing procedures, however in the event a problem should arise please contact our customer service department promptly so we can address your concerns in a timely manner.

### **Customer Service**

**Toll Free: 844-984-6659 Option 6**

**Monday - Friday 9-5 EST**