

Model XPH07M/XPH07Z Parts List

A = Standard Equipment

O = Circuit Diagram

Item#	MJ Part#	Description	Q'ty	Unit
001	187921-4	HOUSING SET	1	
	C10 263005-3	RUBBER PIN 6	2	PC.
	D10	INC. 21		
002	815S70-8	XPH07 NAME PLATE	1	
003	266130-9	TAPPING SCREW BIND PT 3X16	7	PC.
004	232220-0	LEAF SPRING	2	PC.
005	126411-2	SPEED CHANGE LEVER ASSEMBL'	1	
	C10 233438-6	COMPRESSION SPRING 4	2	PC.
006	419250-0	F/R CHANGE LEVER	1	PC.
007	650710-5	SWITCH C3JW-4B	1	
008	251468-5	- FLAT HEAD SCREW M6X22	1	PC.
009	766015-4	KEYLESS DRILL CHUCK 13	1	PC.
010	265995-6	TAPPING SCREW 4X18	4	PC.
011	126410-4	GEAR ASSEMBLY	1	
012	142263-3	INDICATOR PANEL COMPLETE	1	
013	424517-3	CUSHION	1	PC.
014	629116-8	STATOR COMPLETE	1	PC.
015	619336-2	ROTOR	1	
016	266130-9	TAPPING SCREW BIND PT 3X16	2	PC.
017	455011-4	REAR COVER	1	
018	620283-2	LED CIRCUIT	1	
019	643899-6	TERMINAL	1	PC.
020	803N96-2	CAUTION LABEL	1	
021	187921-4	HOUSING SET	1	
	C10 263005-3	RUBBER PIN 6	2	PC.
	D10	INC. 1		
A01	122576-8	STOPPER POLE ASS'Y	1	PC.
A02	126413-8	GRIP ASSEMBLY	1	
	C10 142652-2	POLE COMPLETE	1	
	C20 142653-0	ARM R COMPLETE	1	
	C30 265785-7	THUMB SCREW M5X10	1	PC.
	C40 266886-4	HEX. BOLT M8X65	1	
	C50 319129-4	ARM L	1	
	C60 931202-6	HEX. NUT M5	1	PC.
	C70 962055-2	RETAINING RING (INT) R-15	1	PC.
A03	251314-2	+ SCREW M4X12	2	PC.
A04	346449-3	HOOK	1	PC.
A05	452947-8	BIT HOLDER	1	PC.
A06	784637-8	+ BIT 2-45	2	PC.
A07	821524-1	PLASTIC CARRYING CASE	1	PC. (XPH07M)
	C10 162302-3	LATCH	2	PC.
	C20 325809-2	SHAFT	1	PC.
	C30 451749-9	HANDLE	1	PC.
	C40 453473-0	PLASTIC CASE LID	1	PC.
A08	***DC18RC	DC18RC FAST CHARGER	1	PC. (XPH07M)
A09	BL1840	BATTERY BL1840 SET (196402-7)	2	(XPH07M)
A10	450128-8	BATTERY COVER	1	PC. (XPH07M)

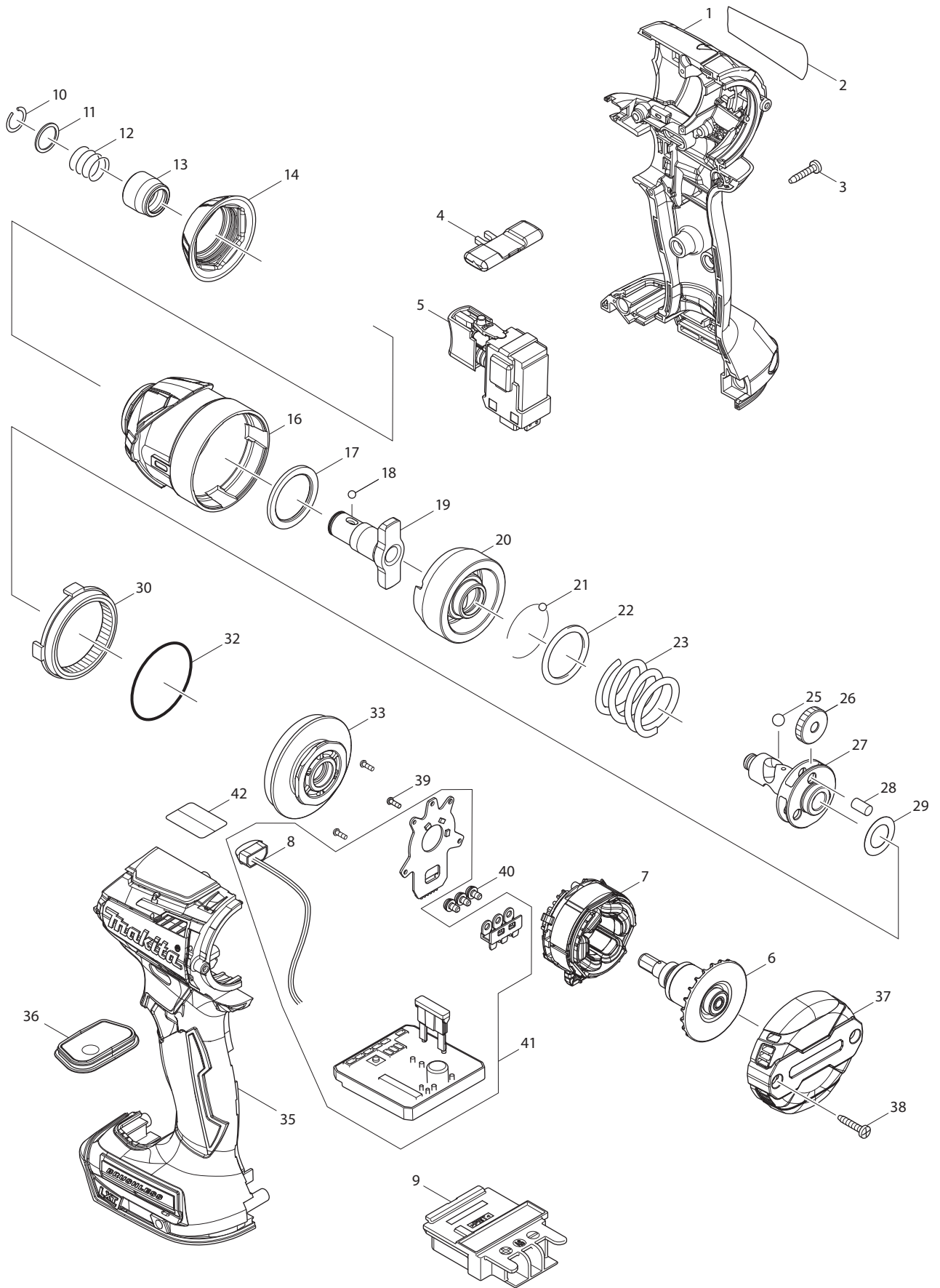

Model XDT14M/R/Z Parts List

A = Standard Equipment

O = Circuit Diagram

Item#	Part#	Description	Q'ty Unit
001	183E36-5	HOUSING SET	1
	C10 263005-3	RUBBER PIN 6	2 PC.
	C20 252126-6	HEX. LOCKING NUT M4-7	2 PC.
	D10	INC. 35	
002	852L15-3	XDT14 NAME PLATE	1
003	266429-2	TAPPING SCREW 3X16	8 PC.
004	455053-8	F/R CHANGE LEVER	1 PC.
005	143975-1	SWITCH COMPLETE	1
006	619408-3	ROTOR	1
007	629217-2	STATOR	1 PC.
008	620557-1	LED CIRCUIT	1
009	643860-3	TERMINAL	1 PC.
010	231951-8	RING SPRING 11	1 PC.
011	267085-1	FLAT WASHER 12	1 PC.
012	233005-7	COMPRESSION SPRING 13	1 PC.
013	326068-1	BIT SLEEVE	1 PC.
014	424873-1	BUMPER	1
016	143951-5	HAMMER CASE COMPLETE	1
017	261155-8	NYLON WASHER 24	1 PC.
018	216001-0	STEEL BALL 3.5	2 PC.
019	326506-3	ANVIL M	1
020	326711-2	HAMMER	1 PC.
021	216001-0	STEEL BALL 3.5	24 PC.
022	267175-0	FLAT WASHER 24	1 PC.
023	234331-7	COMPRESSION SPRING 24	1 PC.
025	216041-8	STEEL BALL 5.6	2
026	227338-0	SPUR GEAR 22	3 PC.
027	326783-7	SPINDLE	1
028	268311-1	PIN 5	3 PC.
029	253314-8	THIN WASHER 15	1 PC.
030	221457-4	INTERNAL GEAR 51	1
032	213507-9	O RING 40	1 PC.
033	143976-9	BEARING BOX COMPLETE	1
035	183E36-5	HOUSING SET	1
	C10 263005-3	RUBBER PIN 6	2 PC.
	C20 252126-6	HEX. LOCKING NUT M4-7	2 PC.
	D10	INC. 1	
036	143954-9	SWITCH PLATE COMPLETE	1
037	456921-8	REAR COVER	1
038	266429-2	TAPPING SCREW 3X16	2 PC.
039	266490-9	TAPPING SCREW PT 2X6	3 PC.
040	652069-6	FLAT HEAD SCREW M3X6	3 PC.
041	620545-8	CONTROLLER	1
	D10	INC. 8	
042	809R92-2	CAUTION LABEL	1
A01	266622-8	+ TRUSS HEAD SCREW M4X12	1 PC.
A02	346449-3	HOOK	1 PC.
A03	450128-8	BATTERY COVER	1 PC.
A04	***DC18RC	DC18RC FAST CHARGER	1 PC. (XDT14M/R)

D10		COMPO-PARTS		
A05	BL1840B	BATTERY BL1840B SET	2	(XDT14M)
	BL1820B	BATTERY BL1820B SET	2	(XDT14R)
A06	824979-9	PLASTIC CARRYING CASE	1 PC.	(XDT14M/R)
C10	162302-3	LATCH	2 PC.	(XDT14M/R)

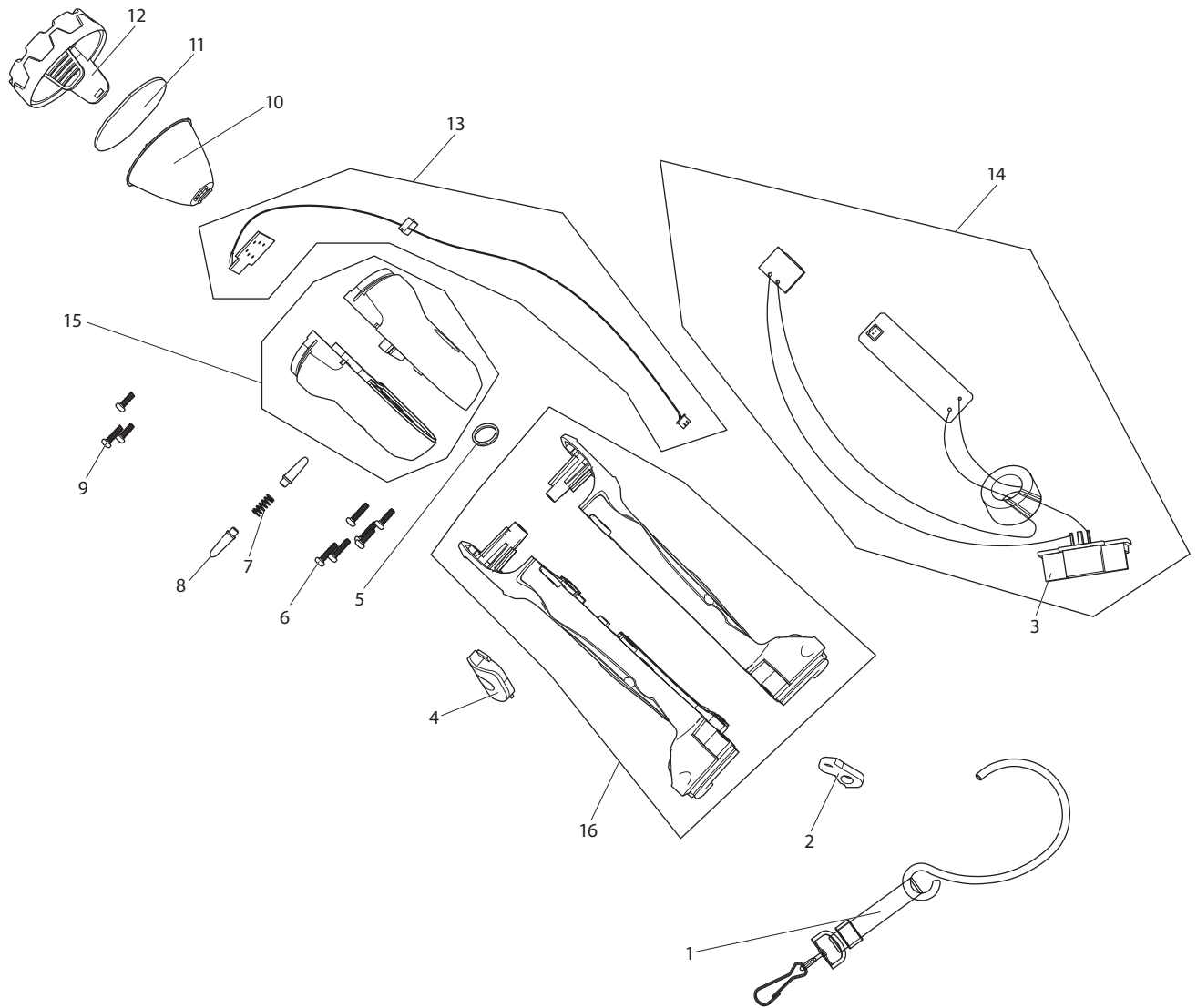

Model DML802 Parts List

A = Standard Equipment

O = Circuit Diagram

Item#	Part#	Description	Q'ty	Unit
001	GM00001289	HOOK BAND SET(G0180200100)	1	PC.
002	GM00001290	HOOK PLATE(B2804802921)	1	PC.
003	GM00001117	BATTERY HOLDER C2010239007	1	PC.
004	GM00001291	SWITCH COVER(G0180200200)	1	PC.
005	GM00001292	RING (B3103184009)	1	PC.
006	GM00001293	SCREW 3X12 PB(B0130120202)	6	PC.
007	GM00001294	COMPRESSION SPRING(B1303802921)	1	PC.
008	GM00001295	LOCKING SHAFT(C4120802001)	2	PC.
009	GM00001296	SCREW M3X8(B0120308099)	3	PC.
010	GM00001297	REFLECTOR(C0120802004)	1	PC.
011	GM00001298	LENS(C1720802001)	1	PC.
012	GM00001299	BEZEL(C1720802002)	1	PC.
013-1	GM00001213	LED CIRCUIT ASS'Y(G0380220100)	1	PC.
014	GM00001301	MAIN CIRCUIT ASS'Y(G0380220200)	1	PC.
015	GM00001302	ALUMINUM HEAD L/R(G0180200300)	1	SET
016	GM00001303	HOUSING L/R(G0180200400)	1	SET