



Installation and Operating Manual

AGC500VF

WARNING

IF THE INFORMATION IN THIS MANUAL IS NOT FOLLOWED EXACTLY, A FIRE OR EXPLOSION MAY RESULT CAUSING PROPERTY DAMAGE, PERSONAL INJURY OR LOSS OF LIFE.

- Do not store or use gasoline or other flammable vapors and liquids in vicinity of this or any other appliance.

WHAT TO DO IF YOU SMELL GAS:

- Do not try to light any appliance.
- Do not touch any electrical switch; do not use any phone in your building.
- Immediately call your gas supplier from a neighbor's phone. Follow gas supplier's instructions
- If you cannot reach your gas supplier, call fire department.
- Installation and service must be performed by a qualified installer, service agency or gas supplier.

This is an unvented gas-fired heater. It uses air (oxygen) from room in which it is installed. Provisions for adequate combustion and ventilation air must be provided. Refer to section, "Producing Adequate Air For Combustion And Ventilation". This appliance may be installed in an aftermarket, permanently located, manufactured (mobile) home, where not prohibited by local codes. This appliance is only for use with type of gas indicated on rating plate. This appliance is not convertible for use with other gases.

INSTALLER: Leave this manual with appliance.
CONSUMER: Retain this manual for future reference.

This appliance is intended for supplemental heating.



Certified for installations in the USA
Approved for installation in mobile homes

852404-1904E

IMPORTANT SAFETY INFORMATION

Congratulations!

PLEASE READ THE INSTALLATION & OPERATING INSTRUCTIONS BEFORE USING APPLIANCE.

Thank you and congratulations on your purchase of an Ashley stove.

IMPORTANT: Read all instructions and warnings carefully before starting installation. Failure to follow these instructions may result in a possible fire hazard and will void the warranty.

IMPORTANT: READ THIS OWNER'S MANUAL CAREFULLY AND COMPLETELY BEFORE TRYING TO ASSEMBLE, OPERATE, OR SERVICE APPLIANCE. IMPROPER USE OF THESE LOGS CAN CAUSE SERIOUS INJURY OR DEATH FROM BURNS, FIRE, EXPLOSION AND CARBON MONOXIDE POISONING.

IMPORTANT: VENT-FREE HEATERS ADD MOISTURE TO AIR. ALTHOUGH THIS IS BENEFICIAL, INSTALLING HEATER IN ROOMS WITHOUT ADEQUATE VENTILATION MAY CAUSE MILDEW TO FORM FROM TOO MUCH MOISTURE.

WARNING

"ANY CHANGE TO THIS HEATER OR ITS CONTROLS CAN BE DANGEROUS."

WARNING

- Any change to this heater or its controls can be dangerous.
- Improper installation or use of the heater can cause serious injury or death from fire, burns, explosion or carbon monoxide poisoning.
- Do not allow fans to blow directly into the stove. Avoid any drafts that alter burner flame patterns.
- Do not use a blower insert, heat exchanger insert or other accessory, not approved for use with this heater where applicable.

1. Due to high temperatures, the appliance should be located out of traffic and away from furniture and draperies.
2. Children and adults should be alerted to the hazard of high surface temperature and should stay away to avoid burns or clothing ignition.
3. Young children should be carefully supervised when they are in the same room with the appliance.
4. Do not place clothing or other flammable material on or near the appliance.
5. Any safety screen or guard removed for servicing an appliance, must be replaced prior to operating the heater.
6. Installation and repair should be done by a qualified service person.
7. To prevent malfunction and/or sooting, an unvented gas heater should be cleaned before use and at least annually by a professional service person. More frequent cleaning may be required due to excessive lint from carpeting, bedding material, etc. It is imperative that control compartments, burners and circulating air passageways be kept clean.
8. **CARBON MONOXIDE POISONING:** Early signs of carbon monoxide poisoning are similar to the flu with headaches, dizziness and/or nausea. If you have these signs, obtain fresh air immediately. Have the heater serviced as it may not be operating properly.
9. The installation must conform with local codes or, in the absence of local codes, with the **National Fuel Gas Code, ANSI Z223.1/NFPA54**.
10. This unit complies with the latest edition of ANSI Z21.11.2, Unvented Heaters.
11. Do not install heater in a bathroom or bedroom unless approved for bedroom use.
12. Correct installation of the ceramic fiber logs, proper location of the heater, and annual cleaning are necessary to avoid potential problems with sooting. Sooting, resulting from improper installation or operation, can settle on surfaces outside the fireplace. See log placement instructions for proper installation.

IMPORTANT SAFETY INFORMATION

13. Avoid any drafts that alter burner flame patterns. Do not allow fans to blow directly into fireplace. Do not place a blower inside burn area of firebox. Ceiling fans may create drafts that alter burner flame patterns. Sooting and improper burning will occur.
14. **Caution:** Candles, incense, oil lamps, etc. produce combustion by-products including soot. Vent-free appliances will not filter or clean soot produced by these types of products. In addition, the smoke and/or aromatics (scents) may be reburnt in the vent-free appliance which can produce odors. It is recommended to minimize the use of candles, incense, etc. while the vent-free appliance is in operation.
15. This is an unvented gas-fired heater. It uses air (oxygen) from the room in which it is installed. Provisions for adequate combustion and ventilation air must be provided.
16. This heater shall not be installed in a room or space unless the required volume of indoor combustion air is provided by the method described in the National Fuel Gas Code, ANSI Z223.1/NFPA 54, the International Fuel Gas Code or applicable local codes.
17. Keep room area clear and free from combustible materials, gasoline and other flammable vapors and liquids.
18. Unvented gas heaters are a supplemental zone heater. They are not intended to be a primary heating appliance.
19. Unvented gas heaters emit moisture into the living area. In most homes of average construction, this does not pose a problem. In houses of extremely tight construction, addition mechanical ventilation is recommended.
20. During manufacturing, fabricating and shipping, various components of this appliance are treated with certain oils, films or bonding agents. These chemicals are not harmful but may produce annoying smoke and smells as they are burned off during the initial operation of the appliance; possibly causing headaches or eye or lung irritation. This is a normal and temporary occurrence. The initial break-in operation should last two to three hours with the burner at the highest setting. Provide maximum ventilation by opening windows or doors to allow odors to dissipate. Any odors remaining after this initial break-in period will be slight and will disappear with continued use.
21. Input ratings are shown in BTU per hour and are for elevations up to 2,000 feet. For elevations above 2,000 feet, input ratings should be reduced 4 percent for each 1,000 feet above sea level. Refer to the National Fuel Gas Code.
22. The appliance and its appliance main gas valve must be disconnected from the gas supply piping system during any pressure testing of that system at test pressures in excess of 1/2 psig (3.5 kPa).
23. The appliance must be isolated from the gas supply piping system by closing its equipment shutoff valve during any pressure testing of the gas supply piping system at test pressures equal to or less than 1/2 psig (3.5 kPa).
24. Do not use this room heater if any part has been under water. Immediately call a qualified service technician to inspect the room heater and to replace any part of the control system and any gas control which has been under water.
25. Never burn solid fuels in an unvented room heater, fireplace or stove.
26. Do not set kettles or humidifying devices on top of stove.
27. The stove door/screen must be closed when the appliance is operating. The screen shall have openings for induction of combustion air.

CODES

Adhere to all local codes or, in their absence, the latest edition of THE NATIONAL FUEL GAS CODE ANSI Z21.88/CSA 2.33-2014 or NFPA54 which can be obtained from...
American National Standards Institute, Inc.
1430 Broadway
New York, NY 10018
or
National Fire Protection Association, Inc.
Batterymarch Park
Quincy, MA 02269

**NATIONAL
FIREPLACE
INSTITUTE**



CERTIFIED
www.nficertified.org

We recommend that our gas hearth products be installed and serviced by professionals who are certified in the U.S. by the National Fireplace Institute® (NFI) as NFI Gas Specialists.

Proposition 65 Warning: Fuels used in gas, wood burning or oil fired appliances, and the products of combustion of such fuels, contain chemicals known to the State of California to cause cancer, birth defects and other reproductive harm.

California Health & Safety Code Sec. 25249.6

PRODUCT FEATURES

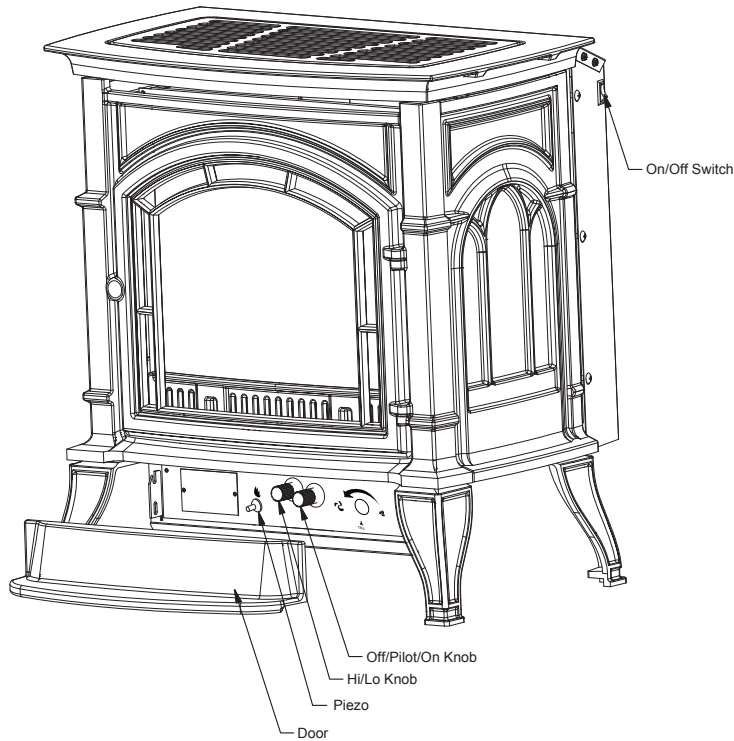

IGNITION CONTROLS

Piezo ignitor allows ignition of the pilot without the use of matches.

Millivolt control has four (4) positions:

- OFF - All gas to the burner is shut off at the valve.
- IGN - Valve position to light/maintain a standing pilot.
- ON - Valve position to turn burners ON/OFF.
- LOW/HI - Variable position to control flame height (heat output). Both front and rear burners are in operation to provide realistic glow and yellow flame.

PILOT / ODS

The gas log heater is fitted with a specially designed safety pilot (ODS assembly) light which senses the amount of oxygen available in the room and shuts the gas log heater off if the oxygen level begins to drop below a satisfactory level. The pilot can only be relit when adequate fresh air is available.

Gas Pressures		
	Natural	Propane (LP)
Regulator Pressure	3.5" w.c.	10.0" w.c.
Pilot Regulator	3.5" w.c.	n/a
Max. Gas Inlet Pressure	10.5" w.c.	13.0" w.c.
Min. Gas Inlet Pressure	5.0" w.c.	11.0" w.c.

Fuel	Control	Max. Input BTU/h	Min. Input BTU/h
Nat.	Millivolt	32,000	23,000
LP	Millivolt	32,000	23,000

NOTE: An external regulator is required to reduce supply pressure to a maximum of 10.5" w.c. on Natural Gas systems operating at higher pressure.

NOTE: An external regulator is required to reduce supply pressure to a maximum of 13.0" w.c. for LP systems.

DIMENSIONS

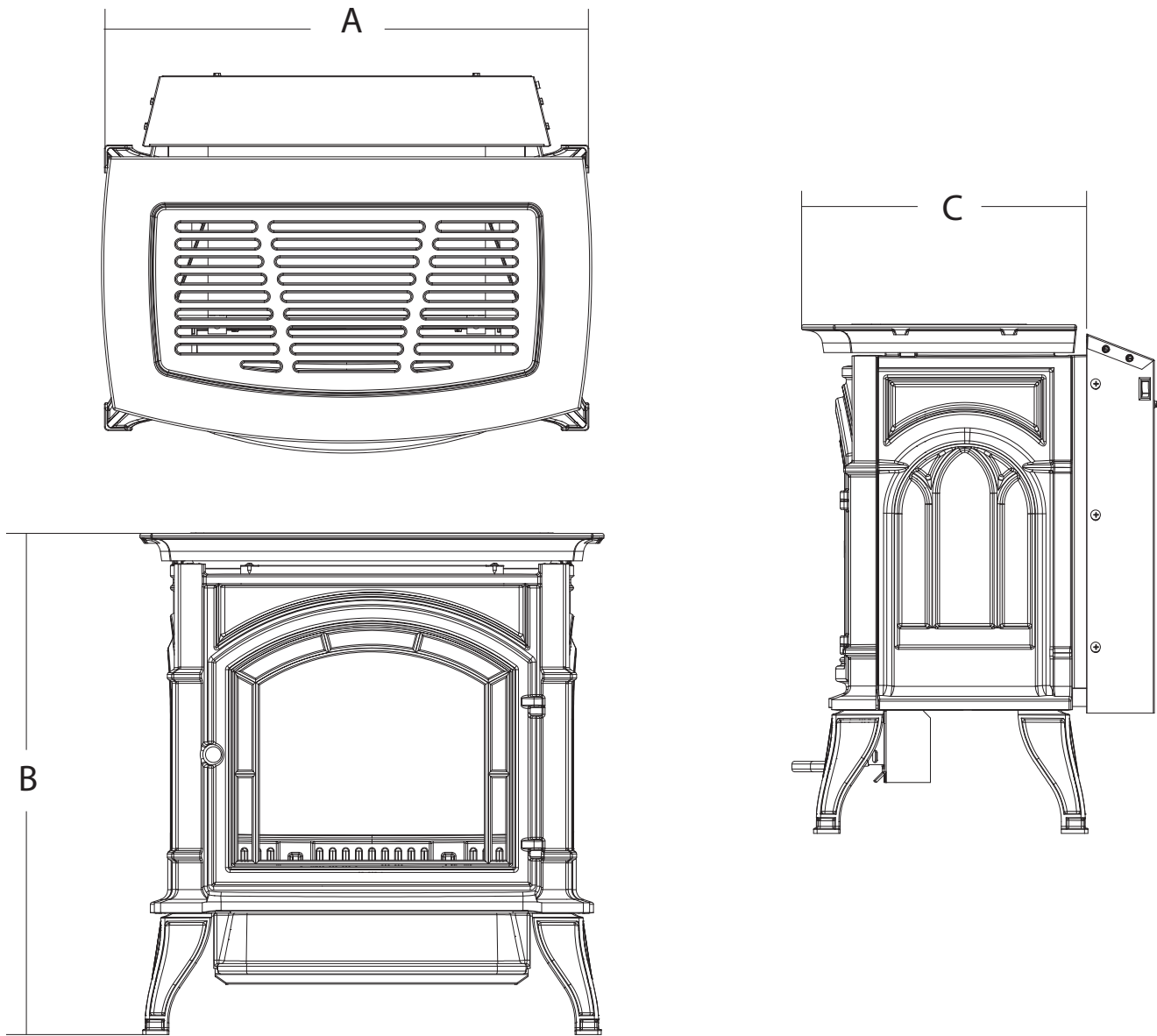

A	26" (660mm)
B	16" (406mm)
C	29" (737mm)

GETTING STARTED

CAUTION: GLOVES ARE RECOMMENDED WHEN HANDLING CERAMIC FIBER LOGS TO PREVENT SKIN IRRITATION FROM LOOSE FIBERS. LOGS ARE FRAGILE — HANDLE WITH CARE.

MAKE SURE YOU HAVE RECEIVED ALL PARTS

Check your packing list to verify that all listed parts have been received. You should have the following:

- Cast Iron Stove with Burner Assembly
- Installation/Operating Instructions
- Ceramic Fiber Logs

Carefully inspect the contents for shipping damage. If any parts are missing or damaged, immediately inform the dealer from whom you purchased the appliance. Do not attempt to install any part of the appliance unless you have all parts in good condition.

WHAT THE GAS TECHNICIAN WILL NEED FOR INSTALLATION

You must have the following items available before proceeding with installation:

- External regulator (for Propane/LPG) or high pressure natural gas (1 to 2 psi system)
- Piping which complies with local codes
- Sediment trap (recommended)
- Pipe wrench
- Pipe sealant approved for use with propane/LPG (resistant to sulfur compounds)
- Manual shutoff valve
- Tee joint
- Screwdrivers

WARNING

DO NOT INSTALL THE HEATER ...

- **Where curtains, furniture, clothing, or other flammable objects are less than 42" from the heater.**
- **In high traffic areas.**
- **In windy or drafty areas.**

WARNING

IF THE AREA IN WHICH THE HEATER MAY BE OPERATED DOES NOT MEET THE REQUIRED VOLUME FOR INDOOR COMBUSTION AIR, COMBUSTION AND VENTILATION AIR SHALL BE PROVIDED BY ONE OF THE METHODS DESCRIBED IN THE NATIONAL FUEL GAS CODE, ANSI Z223.1/NFPA 54, THE INTERNATIONAL FUEL GAS CODE OR APPLICABLE LOCAL CODES.

CLEARANCES AND HEIGHT REQUIREMENTS

WARNING

THE DIMENSIONS SHOWN ARE MINIMUM CLEARANCES TO MAINTAIN IN INSTALLING THIS HEATER. LEFT AND RIGHT CLEARANCES ARE DETERMINED WHEN FACING THE FRONT OF THE HEATER. FOLLOW THESE INSTRUCTIONS CAREFULLY TO ENSURE SAFE INSTALLATION. FAILURE TO FOLLOW INSTRUCTIONS EXACTLY CAN CREATE A FIRE HAZARD. THE APPLIANCE CANNOT BE INSTALLED ON A CARPET, TILE OR OTHER COMBUSTIBLE MATERIAL. THE APPLIANCE SHALL BE INSTALLED ON A NONCOMBUSTIBLE MATERIAL PANEL EXTENDING THE FULL WIDTH AND DEPTH OF THE APPLIANCE.

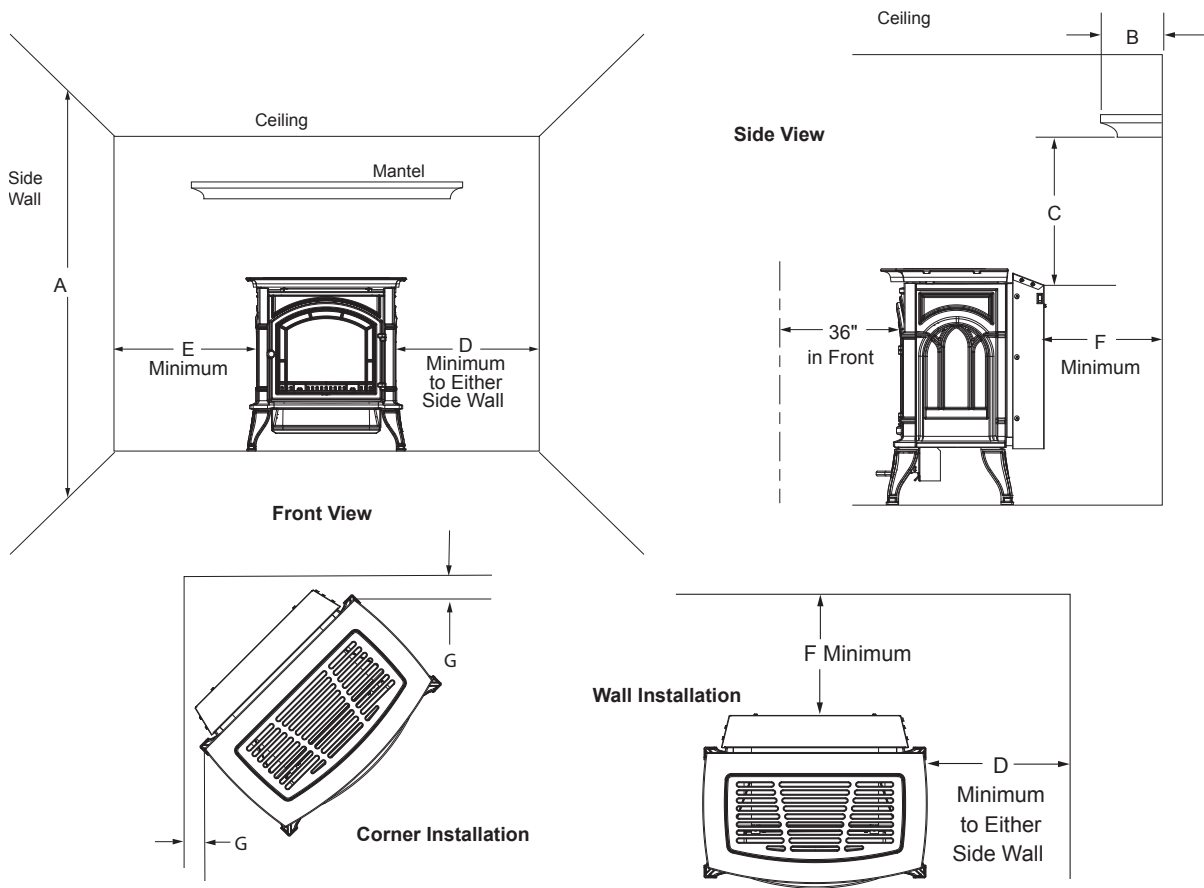

Minimum Clearances

Min Ceiling From Floor	Mantel Clearance From Top Of Unit		Side Measured From		Rear Measured From Back	Corner Measured From Top Corners
	Max. Protrusion	Min. Height	Right	Left		
A	B	C	D	E	F	G
72"	12"	18"	2"	2"	1"	1/2

CLEARANCES/HEIGHT REQUIREMENTS

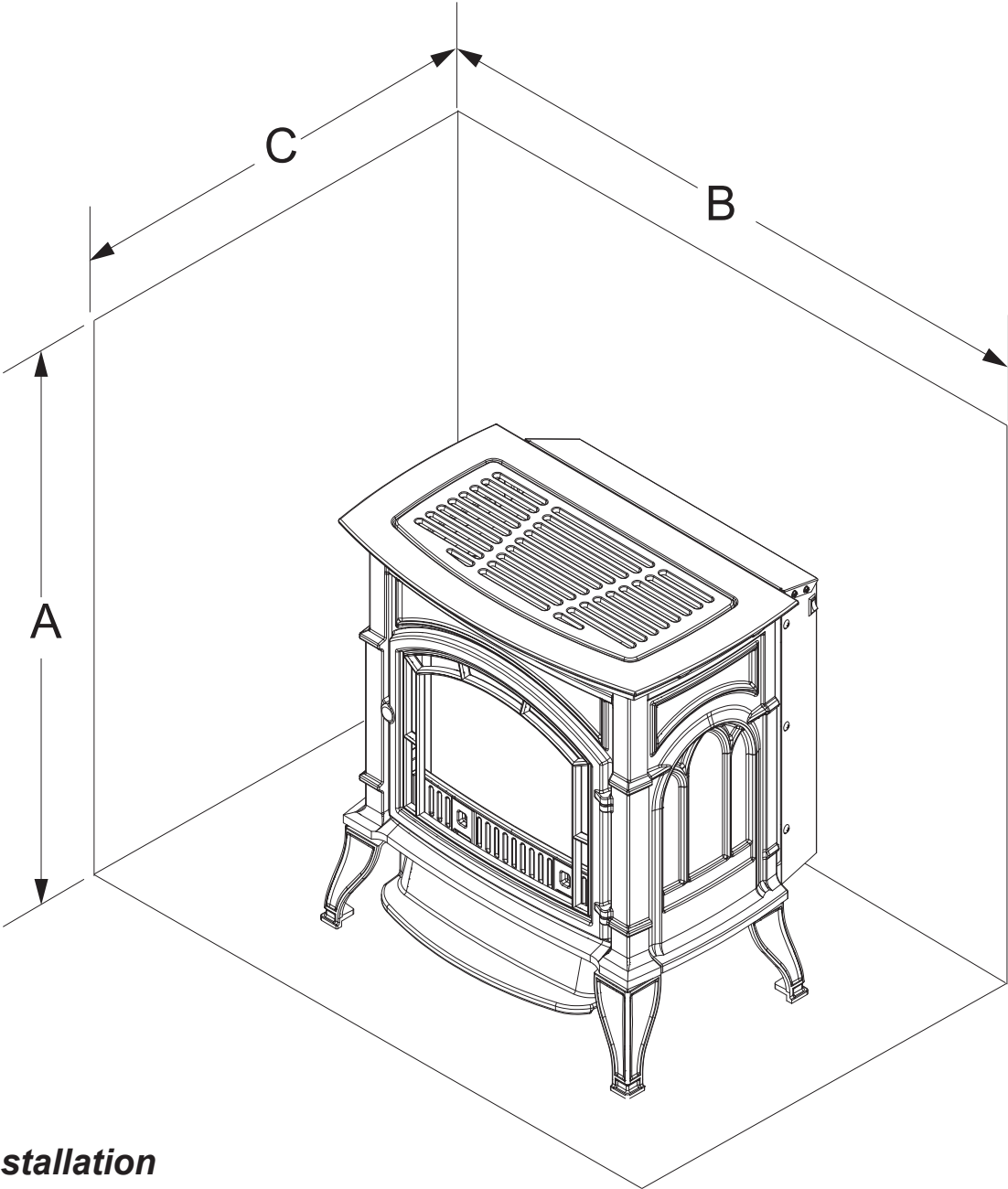

Alcove Installation

NOTE: Maintain minimum side and back clearances when placing stove in alcove.

Alcove Minimum Dimensions		
Height From Hearth	Width	Depth
A	B	C
52"	34"	36"

INSTALLATION

1. Remove two (2) straps.
2. Open plastic bag and slide to bottom of unit.
3. Lift up on ash lip and pivot down to open control door.
4. Lift up on front. Pivot bottom of front out. Remove front.
5. Open and remove glass door.
6. Remove log box from inside of unit.
7. Lift unit off pallet. Lift unit up high enough to clear upright supports unit is sitting on.

NOTE: You will need at least two (2) strong people to lift unit off of pallet.

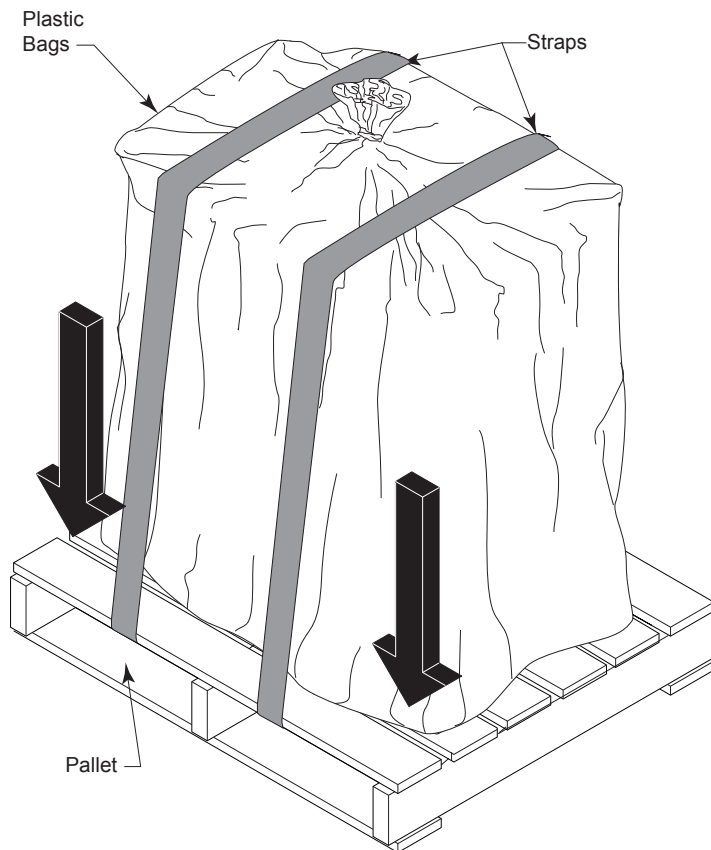

Remove Straps and Plastic from Unit

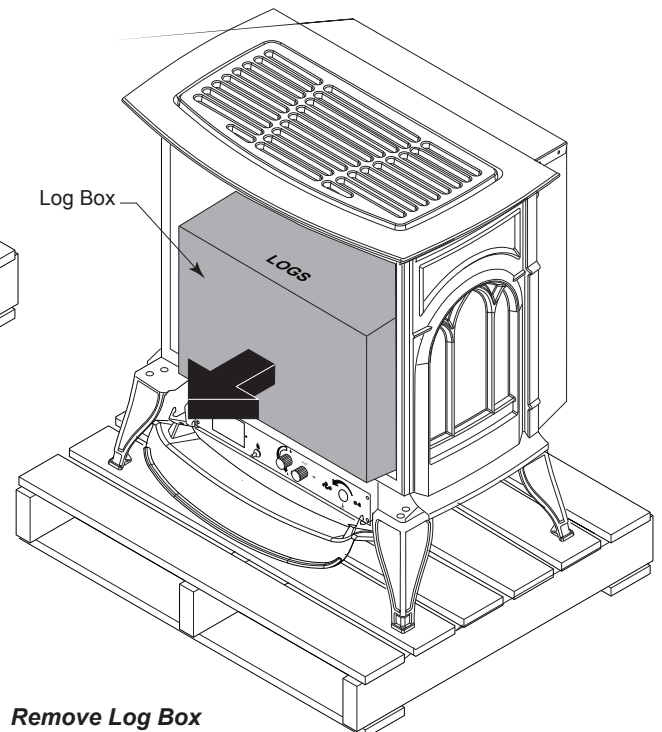

Remove Log Box

CAUTION! THE APPLIANCE IS VERY HEAVY. THE ASSISTANCE FROM A SECOND PERSON IS STRONGLY SUGGESTED. PLEASE USE PROPER LIFTING TECHNIQUE WHEN POSITIONING THE APPLIANCE FOR ASSEMBLY AND INSTALLATION.

CONNECT GAS LINE

WARNING

Use new black iron or steel pipe. Internally tinned copper or copper tubing can be used per National Fuel Code, section 2.6.3, providing gas meets hydrogen sulfide limits, and where permitted by local codes. Gas piping system must be sized to provide minimum inlet pressure (Listed on Data Plate) at the maximum flow rate (BTU/hr). Undue pressure loss will occur if the pipe is too small.

A manual shutoff valve must be installed upstream of the appliance. Union tee and plugged 1/8" NPT pressure tapping point should be installed upstream of the appliance. A sediment trap should be installed upstream to prevent moisture and contaminants from passing through the pipe to appliance controls and burners. Failure to do so could prevent the appliance from operating reliable.

NOTICE: A qualified gas appliance installer must connect the heater to the gas supply. Consult all local codes.

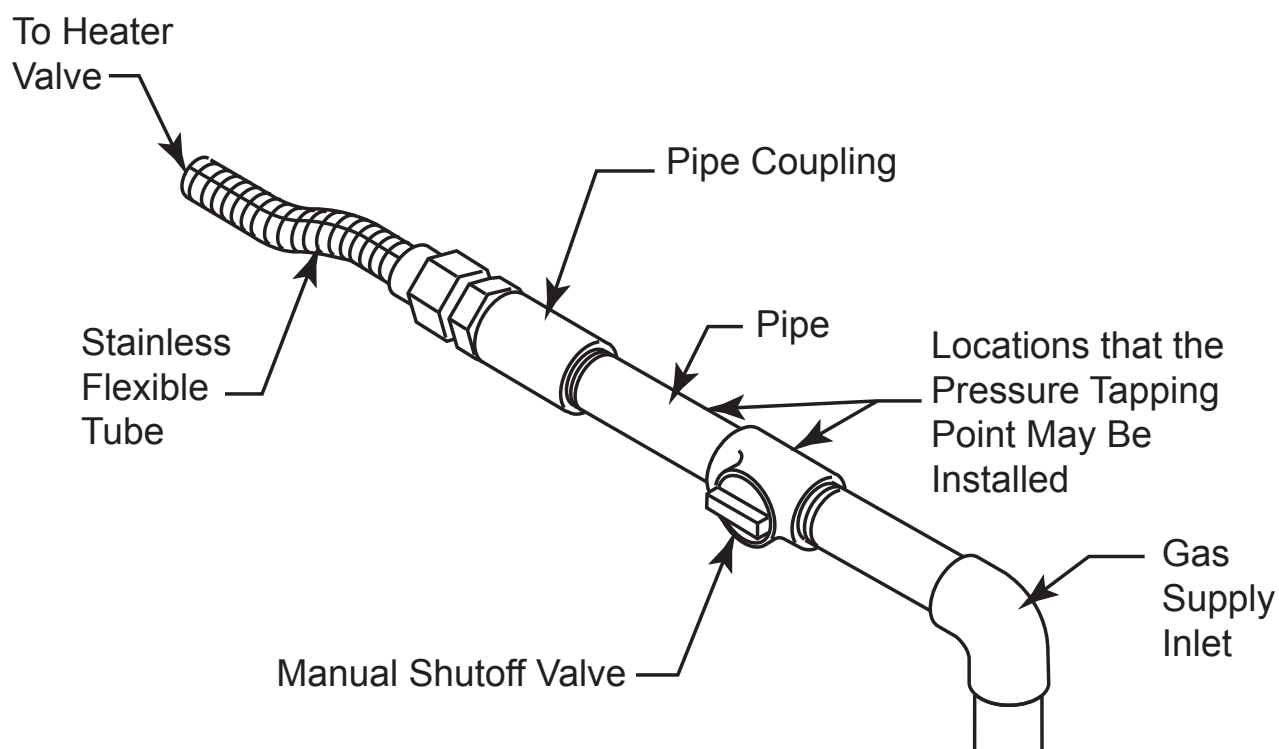

Gas Connection

IMPORTANT: Hold heater valve firmly with a wrench to prevent movement when connecting to inlet pipe. Always use an external regulator for all propane/LPG heaters and high pressure one to two-pound systems only, to reduce the supply tank pressure to a maximum of 13" w. This is in addition to the internal regulator in the heater valve.

CHECK GAS TYPE : The gas supply must be the same as stated on the heater's rating plate. If the gas supply is different, DO NOT INSTALL THE HEATER. Contact your dealer for the correct model.

ELECTRICAL WIRING (MILLIVOLT)

The millivolt valve is a self-powered combination gas control THAT DOES NOT REQUIRE 110V AC TO OPERATE .

CAUTION: LABEL ALL WIRES PRIOR TO DISCONNECTION WHEN SERVICING CONTROLS. WIRING ERRORS CAN CAUSE IMPROPER AND DANGEROUS OPERATION. VERIFY PROPER OPERATION AFTER SERVICING.

CONNECT OPTIONAL WALL SWITCH

1. Use 18 awg, two-wire cable, 15 feet maximum length.
2. At one end of the cable, connect both wires to the wall switch. At the other end, connect one wire to TP/TH and one wire to TH, or connect the wall switch to the two male (0.25") terminals on the left side of the unit.

CHECK SYSTEM OPERATION

The millivolt system and individual components may be checked with a millivolt meter having a 0-1000 mV range. Conduct each check shown in chart below by connection meter test leads to terminals as indicated.

A. Complete Millivolt System Check

("A" Reading - Thermostat contacts CLOSED - Control Knob "ON" - Main burner should turn ON)

- a. If the reading is more than 100 millivolts and the automatic valve still does not come on, replace the control.
- b. If the closed circuit reading ("A" reading) is less than 100 millivolts, determine cause for low reading, proceed to Section B below.

B. Thermopile Output Reading Check

("B" Reading - Thermostat contacts OPEN - Main burner OFF)

1. Check gas pressure to the unit. If gas pressure is within minimum and maximum on data plate, then check pilot voltage, 325 millivolts minimum. If the minimum millivolt reading is not obtainable, replace pilot.

Check Test	To Test	Connect Meter Leads to Terminals	Switch or Thermostat Contacts	Meter Reading Should Be
A	Complete System	2 & 3	Closed	Closed
B	Thermopile	1 & 2	Open	Open

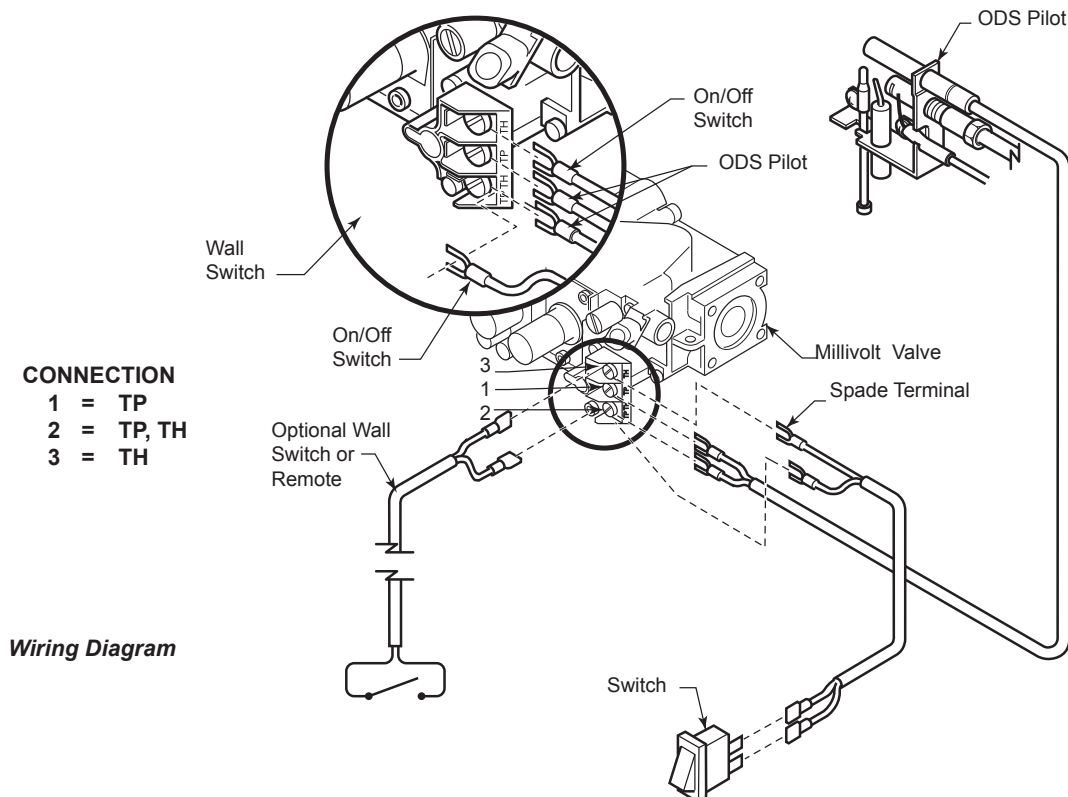

LOG PLACEMENT

WARNING

The positioning of the logs is critical to the safe and clean operation of this heater. Sooting and other problems may result if the logs are not properly and firmly positioned in the appliance. Never add additional logs or embellishments such as pine cones, vermiculite or rock wool to the heater. Only use the logs supplied with the unit.

Failure to position the parts in accordance with diagrams below or to use only parts specifically approved for this heater may result in property damage or personal injury.

Before you begin — This unit is supplied with five ceramic fiber logs. Do not handle these logs with your bare hands. Always wear gloves to prevent skin irritation from ceramic fibers. After handling the logs, wash your hands gently with soap and water to remove any traces of fibers.

LOG PLACEMENT

1. Install back log (#1) on rear log support bracket.
2. Install left bottom log (#2) on left log support bracket in front of back log.
3. Install right bottom log (#3) on right log support bracket in front of back log.
4. Install top left log (#4) on top of left bottom log.
5. Install top right log (#5) on top of right bottom log.

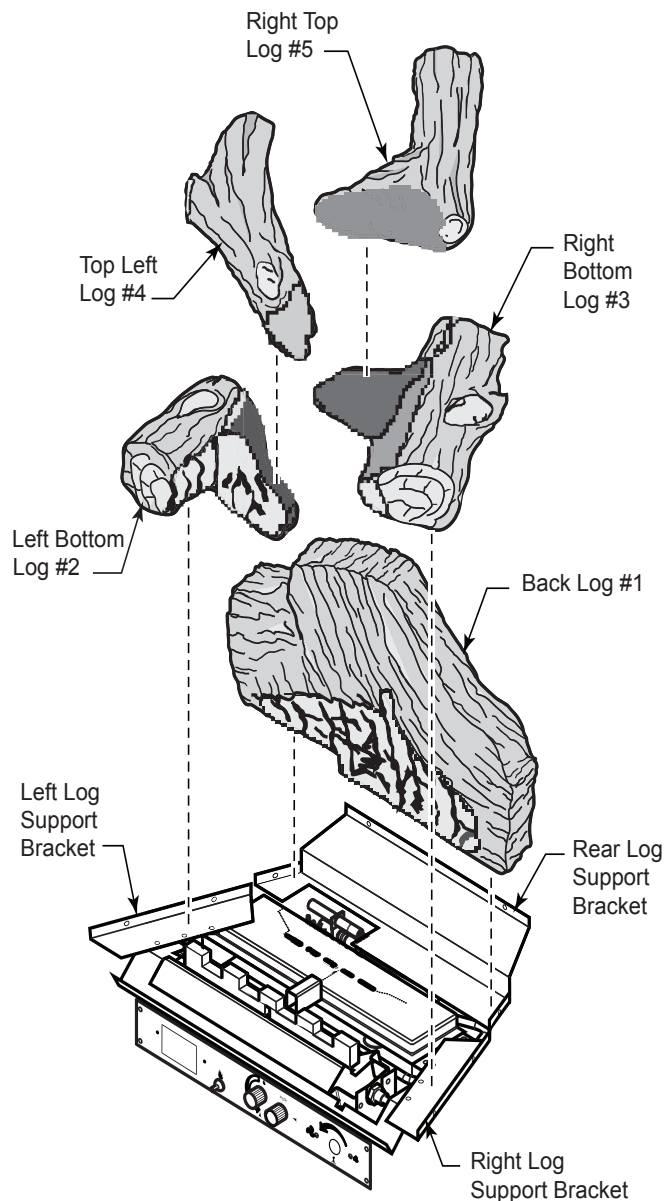

Place Logs on Grate

CAUTION:

During initial operation of the new heater, burning logs will give off a paper burning smell and orange flames will be present. Simply open the windows for a few hours to vent the odor.

FLAME APPEARANCE

Flames from the pilot, front and rear burner should be visually checked as soon as the heater is installed. In addition, periodically check the flames visually during operation.

PILOT FLAME

The pilot flame must always be present when the heater is in operation. It should just touch the top of the thermocouple tip for natural. Refer to the figure below for correct pilot flame.

If the pilot flame does not touch the thermocouple, then the burners cannot function reliably. Refer to the figure below for incorrect shape of pilot flame.

MILLIVOLT CONTROL

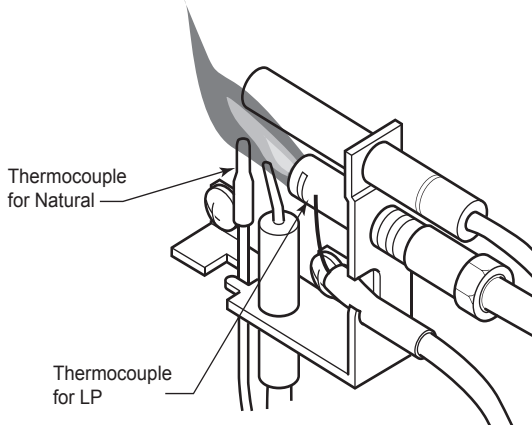

Correct Pilot Flame Appearance

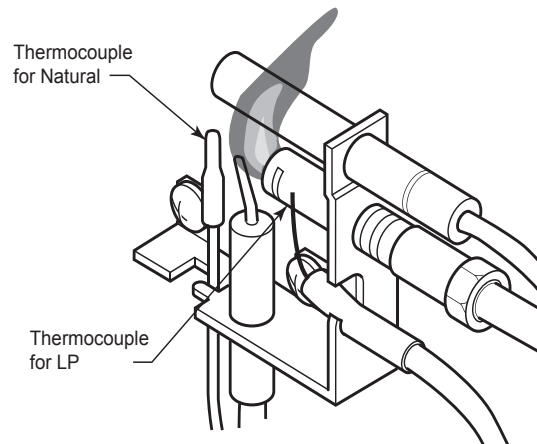

Incorrect Pilot Flame Appearance

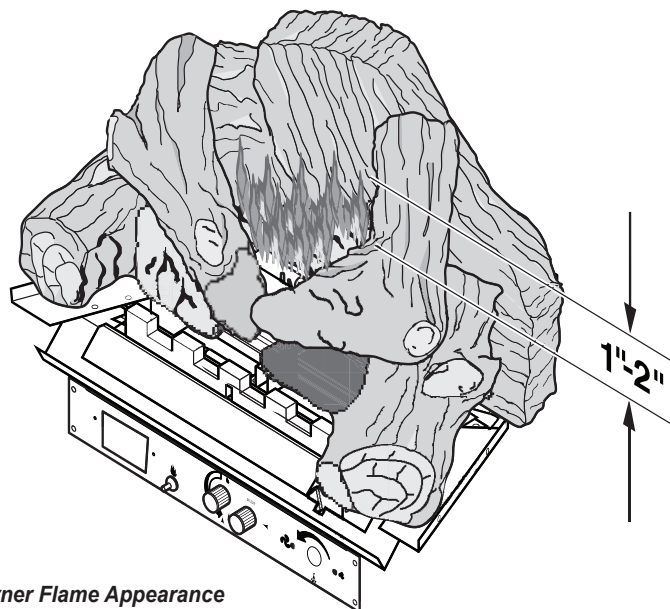

Correct Burner Flame Appearance

BURNER FLAME

In normal operation at full rate after 15 minutes, the following flame appearances should be observed: The left and right rear flames should be yellow and extend 1"- 2" above middle logs. The yellow flames should not contact the logs. There should be glowing embers on the front surface of the middle log.

NOTE The flames and embers will be an opaque orange color during the burn off time.

OPERATING INSTRUCTIONS

OPERATING INSTRUCTIONS

Avoid any drafts that alter burner flame patterns. Do not allow fans to blow directly into the stove. Do not place a blower inside the burn area of the stove. Ceiling fans may create drafts that alter flame patterns. Sooting and improper burning will result.

During manufacturing, fabricating and shipping, various components of this appliance are treated with certain oils, films or bonding agents. These chemicals are not harmful, but may produce annoying smoke and smells as they are burned off during the initial operation of the appliance, possibly causing headaches or eye or lung irritation. This is a normal and temporary occurrence.

The initial break-in operation should last two to three hours with the burner at the highest setting. Provide maximum ventilation by opening windows or doors to allow odors to dissipate. Any odors remaining after this initial break-in will be slight and will disappear with continued use.

FOR YOUR SAFETY READ BEFORE LIGHTING

WARNING

IF YOU DO NOT FOLLOW THESE INSTRUCTION EXACTLY, A FIRE OR EXPLOSION MAY RESULT CAUSING PROPERTY DAMAGE, PERSONAL INJURY OR LOSS OF LIFE.

- A. This appliance is equipped with an ignition device which automatically lights the pilot. If the piezo is not working properly, refer to Match Lighting instructions.
- B. BEFORE OPERATING smell all around the appliance area for gas. Be sure to smell next to the floor because some gas is heavier than air and will settle on the floor.

WHAT TO DO IF YOU SMELL GAS:

- Turn off all gas to the appliance.
- Open windows.
- Do not attempt to light any appliance.
- Do not touch any electric switch; do not use any phone in your building.
- Immediately call your gas supplier from a neighbor's phone. Follow the gas supplier's instructions.

If you cannot reach your gas supplier, call the fire department.

- C. Use only your hand to push in, or turn the gas control knob. Never use tools. If the knob will not push in or turn by hand, don't try to repair it. Call a qualified service technician. Force or attempted repair may result in a fire or explosion.
- D. Do not use this appliance if any part of it has been under water. Immediately call a qualified service technician to inspect the appliance and to replace any part of the control system and any gas control that has been under water.

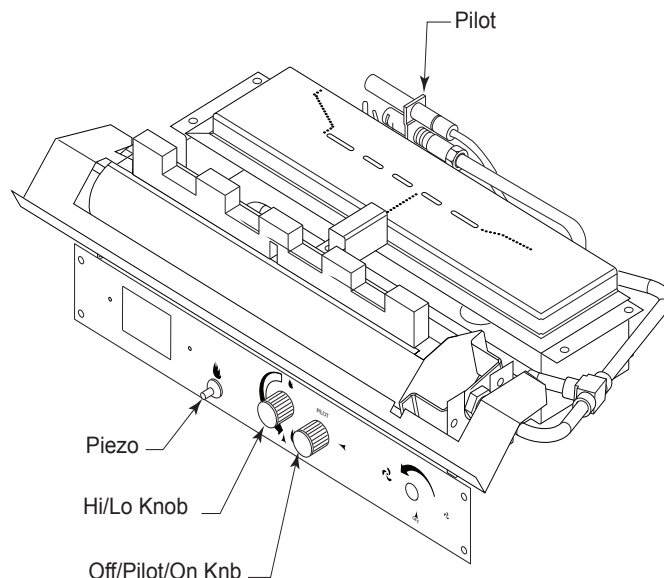

Burner Controls - Piezo Ignitor, Control Knobs

OPERATING INSTRUCTIONS

MILLIVOLT CONTROL LIGHTING INSTRUCTIONS

1. STOP! Read the safety information label.
2. Make sure the manual shutoff valve is fully open.
3. This gas log set is equipped with an ignition device (piezo) which automatically lights the pilot. If piezo ignitor does not light the pilot, refer to instructions for "Match Lighting Instructions".
4. Turn gas control knob clockwise to the OFF position, and turn ON/OFF switch to OFF position.
5. Wait (5) minutes to clear out any gas. Then smell for gas, including near the floor. If you smell gas, STOP! Follow "What to Do if You Smell Gas". If you don't smell gas, go to next step.
6. From OFF position, turn the gas control knob counterclockwise to IGN position. Push in control knob for 5 seconds. NOTE: If you are running the heater for the first time, it will be necessary to press in the control knob for 30 seconds to allow air to bleed out of the gas piping.
7. With the control knob pushed in, push in and release the piezo ignitor button to light the pilot.
8. Continue pushing the control knob in for a further 10 seconds to prevent the flame detector from shutting off the gas while the probe is warming up. Release the control knob.
9. Turn gas control knob counterclockwise to the ON position.
10. After the pilot has been lit for one minute, the burners can be turned on. Turn the ON/OFF switch to ON position.
11. If the gas logs will not operate, follow the instructions "To Turn Off Gas To Heater" below and call your service technician or gas supplier.

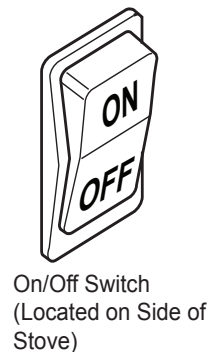
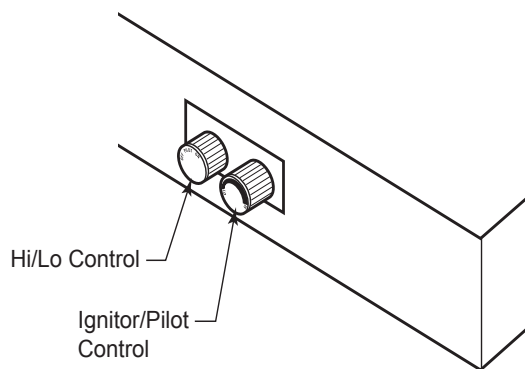
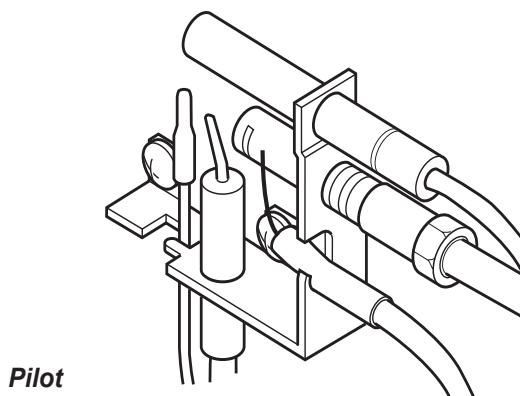

Control Cover Plate for Millivolt

TO TURN OFF GAS TO HEATER

1. Turn ON/OFF switch to OFF position.
2. Turn control knob clockwise to OFF position to completely shut off the heater.
3. If applicable: Turn off all electric power to the heater.

MATCH LIGHTING INSTRUCTIONS

1. Open stove door. Remove any items necessary for easy access to the pilot (for example: logs, screens, etc.).
2. Follow appropriate lighting instructions found previously. Instead of pushing and releasing the piezo button, light a match and hold the flame to the end of the pilot and ignite the pilot.
3. After control knob has been released and pilot stays lit, reinstall any items that were removed for pilot access.
4. Call a qualified service technician for repair or replacement of the piezo ignitor.

CLEANING AND SERVICING

WARNING

TURN OFF HEATER AND ALLOW TO COOL BEFORE CLEANING. DISCONNECT ELECTRICAL POWER BEFORE CLEANING OR SERVICING.

CLEANING AND SERVICING

Annual inspection and cleaning by your dealer or qualified service technician is recommended to prevent malfunction and/or sooting.

Remove logs, handling carefully by holding gently at each end. Gloves are recommended to prevent skin irritation from ceramic fibers. If skin becomes irritated, wash gently with soap and water. Refer to manual for correct log placement.

Periodic Cleaning - See parts diagram for location of items discussed below.

- Do not use cleaning fluid to clean logs or any part of heater.
- Brush logs with soft bristle brush or vacuum with brush attachment.
- Vacuum loose particles and dust from the front and rear burners, control and piezo covers and grate weldment.
- Inspect and clean burner air intake holes. Remove lint or particles with vacuum, brush, or pipe cleaners. Failure to keep air intake holes clean will result in sooting and poor combustion.
- External case should be dusted and wiped with a moist cloth.

Annual Cleaning /Inspection - Refer to parts diagram for location of items discussed below.

- Inspect and clean burner air intake holes. Remove lint or particles with vacuum, brush or pipe cleaners. Failure to keep air intake holes clean will result in sooting and poor combustion.
- Inspect and clean all burner ports.
- Inspect ODS pilot for operation and accumulation of lint at air intake holes.
- Verify flame pattern and log placement for proper operation.
- Verify smooth and responsive ignition of main burner and rear burner.

TROUBLESHOOTING

WARNING

TURN APPLIANCE OFF AND ALLOW TO COOL BEFORE SERVICING. ONLY A QUALIFIED SERVICE PERSON SHOULD SERVICE AND REPAIR THE HEATER.

NOTE: All troubleshooting items are listed in order of operation.

OBSERVED PROBLEM	POSSIBLE CAUSE	REMEDY
When ignitor button is pressed, there is no spark at ODS/pilot.	<ol style="list-style-type: none"> 1. Ignitor electrode positioned wrong. 2. Ignitor electrode is broken. 3. Ignitor electrode not connected to ignitor cable. 4. Ignitor cable pinched or wet. Keep ignitor cable dry. 5. Broken ignitor cable. 6. Bad piezo ignitor. 	<ol style="list-style-type: none"> 1. Replace ignitor. 2. Replace ignitor. 3. Reconnect ignitor cable. 4. Free ignitor cable if pinched by any metal or tubing. 5. Replace ignitor cable. 6. Replace piezo ignitor.
Appliance produces unwanted odors.	<ol style="list-style-type: none"> 1. Appliance burning vapors from paint, hair spray, glues, etc. 2. Gas leak. 3. Initial burn off. 	<ol style="list-style-type: none"> 1. Ventilate room. Stop using odor causing products while heater is running. 2. Locate and correct all leaks. 3. Ventilate room and turn unit on high until odor is gone. Odor should be gone after 6 hours of continuous use.
Appliance shuts off during use.	<ol style="list-style-type: none"> 1. Not enough fresh air is available for ODS/ pilot to operate. 2. Low line pressure. 3. ODS/pilot is partially clogged. 4. Defective Thermopile. 5. Restrictions in incoming air flow. 	<ol style="list-style-type: none"> 1. Open window and/or door for ventilation. 2. Contact local gas company. 3. Clean ODS/pilot. 4. Check pilot flame, check wire connections, check output, should be 325 millivolts across TH/TP and TP Terminals with ON/OFF switches off. 5. Check for bottom riser on glass door, sunken fireplace, excessive lava rock/cinders densely packed against grate.
Gas odor even when control knob is in OFF position.	<ol style="list-style-type: none"> 1. Gas leak. 2. Control valve defective. 	<p>Locate and correct all leaks. Replace control valve.</p>

TROUBLESHOOTING

WARNING

IF THE GAS QUALITY IS BAD, YOUR PILOT MAY NOT STAY LIT, THE BURNERS MAY PRODUCE SOOT AND THE HEATER MAY BACKFIRE WHEN LIT. IF THE GAS QUALITY OR PRESSURE IS LOW, CONTACT YOUR LOCAL GAS SUPPLIER IMMEDIATELY.

OBSERVED PROBLEM	POSSIBLE CAUSE	REMEDY
ODS/pilot lights, but flame goes out when control knob is released.	<ol style="list-style-type: none"> 1. Control knob not fully pressed in. 2. Control knob not pressed in long enough. 3. Manual shutoff valve not fully open. 4. Thermocouple connection loose at control valve. 5. Pilot flame not touching thermocouple, which allows thermocouple to cool, causing pilot flame to go out. This problem could be caused by either low gas pressure, or a dirty or partially clogged ODS/pilot. 6. Thermocouple damaged. 7. Control valve damaged. 	<ol style="list-style-type: none"> 1. Press in control knob fully. 2. After ODS/pilot lights, keep control knob pressed in for 30 seconds. 3. Fully open manual shutoff valve. 4. Hand tighten thermocouple connection until snug, then tighten 1/4 turn more. 5a. Contact local gas company. 5b. Clean pilot with vacuum cleaner. 6. Replace thermocouple. 7. Replace control valve.
Burner does not light after ODS/pilot is lit.	<ol style="list-style-type: none"> 1. Burner orifice is clogged. 2. Burner orifice diameter is too small. 3. Inlet gas pressure is too low. 	<ol style="list-style-type: none"> 1. Clean orifice. 2. Replace burner orifice. 3. Contact qualified service person
Burner backfires during combustion.	<ol style="list-style-type: none"> 1. Manifold pressure is too low. 2. Burner orifice is clogged. 	<ol style="list-style-type: none"> 1. Contact local gas company. 2. Clean burner or replace burner orifice.
Slight smoke or odor during initial operation.	<ol style="list-style-type: none"> 1. Burner orifice is clogged or damaged. 2. Burner is damaged. 3. Gas regulator defective. 	<ol style="list-style-type: none"> 1. Clean burner or replace burner orifice. 2. Replace burner. 3. Replace gas regulator.
Logs appear to smoke after initial operation.	<ol style="list-style-type: none"> 1. Vapors from paint or curing process of logs. 2. Vapors or smoke continue after heater has run with damper or window open for several hours. 	<ol style="list-style-type: none"> 1. Problem will stop after a few hours of operation. Run the heater with the damper open if you have one, or open a window for the first few hours. 2. Log heater is intended to be smokeless. Turn OFF heater and call qualified service person.
Heater produces a whistling noise when burner is lit.	<ol style="list-style-type: none"> 1. Turning control knob to HIGH position when burner is cold. 2. Air in gas line. 3. Dirty or partially clogged burner orifices. 	<ol style="list-style-type: none"> 1. Turn control knob to LOW position and let warm up for a minute. 2. Operate burner until air is removed from line. Have gas line checked by local gas company. 3. Clean burner or replace burner orifice.
No gas to pilot.	<ol style="list-style-type: none"> 1. LP-regulator shut down due to inlet pressure too high. 	<ol style="list-style-type: none"> 1. Verify LP tank regulator is installed and set at 11" to 13" w.c. 2. Replace regulator on heater.

REPLACEMENT PARTS

Burner Assembly

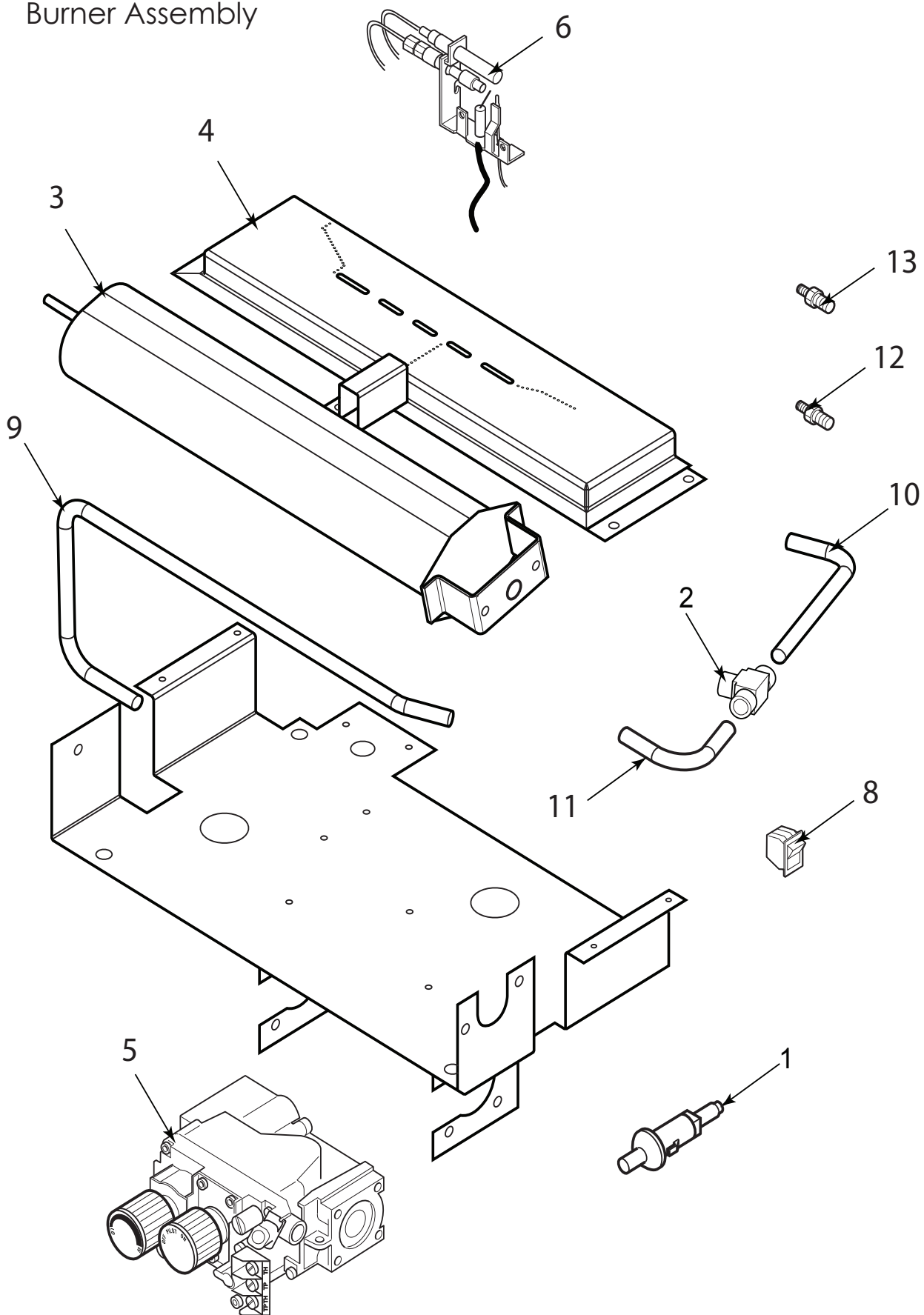

REPLACEMENT PARTS

Ref.	Part No.	Description	Qty.
1	89761	Piezo Ignitor	1
2	81211-11	5/16 Union Tee	1
3	81211-05	Front Burner	1
4	81211-06	Rear Burner	1
5	81196 (LP)	Control Valve	1
	81198 (NAT)		1
6	89922 (LP)	ODS Pilot Assembly	1
7	89921 (NAT)		1
8	81212.14	On/Off Switch	1
9	81211-12	VF Valve Tube	1
10	81211-13	VF Rear Burner Tube	1
11	81211-14	VF Front Burner Tube	1
12	81210-08	Upper Burner Orifices (NAT) # 47	1
13	81210-15	Lower Burner Orifices (NAT) # 47	1
14	81211-16	Upper Burner Orifices (LP) # 56	1
15	81211-17	Lower Burner Orifices (LP) # 55	1

Available Colors
Black
Mahogany
Red

WARNING

FAILURE TO POSITION THE PARTS IN ACCORDANCE WITH THESE DIAGRAMS OR FAILURE TO USE ONLY PARTS SPECIFICALLY APPROVED WITH THIS APPLIANCE MAY RESULT IN PROPERTY DAMAGE OR PERSONAL INJURY.

REQUIREMENTS FOR THE COMMONWEALTH OF MASSACHUSETTS

This product must be installed by a licensed plumber or gas fitter when installed within the Commonwealth of Massachusetts.

NOTE REGARDING VENTED PRODUCTS

Flex line installation must not exceed 36 inches and must have a T shutoff valve.

Any residence with a direct vent product must have a CO detector installed in the residence.

Installation of the fireplace or vented gas log in the State of Massachusetts requires the damper to be permanently removed or welded in the fully open position.

In addition, neither a naturally vented gas log nor a vent-free product may be installed in a bedroom or bathroom in the State of Massachusetts.

All gas fitting and installation of this heater shall only be done by a licensed gas fitter or licensed plumber.

For all side wall horizontally vented gas fueled equipment installed in every dwelling, building or structure used in whole or in part for residential purposes, including those owned or operated by the Commonwealth and where the side wall exhaust vent termination is less than seven (7) feet above finished grade in the area of the venting, including but not limited to decks and porches, the following requirements shall be satisfied:

INSTALLATION OF CARBON MONOXIDE DETECTORS

At the time of installation of the side wall horizontal vented gas fueled equipment, the installing plumber or gas fitter shall observe that a hard wired carbon monoxide detector with an alarm is installed on each additional level of the dwelling, building or structure served by the side wall horizontal vented gas fueled equipment. It shall be the responsibility of the property owner to secure the services of qualified licensed professionals for the installation of hard wired carbon monoxide detectors.

In the event that the side wall horizontally vented gas fueled equipment is installed in a crawl space or an attic, the hard wired carbon monoxide detector with alarm and battery back-up may be installed on the next adjacent floor level. In the event that the requirements of this subdivision can not be met at the time of completion of installation, the owner shall have a period of thirty (30) days to comply with the above requirements; provided, however, that during said thirty (30) day period, a battery operated carbon monoxide detector with an alarm shall be installed.

APPROVED CARBON MONOXIDE DETECTORS

Each carbon monoxide detector as required in accordance with the above provisions shall comply with NFPA 720 and ANSI/UL 2034 listed and IAS certified.

SIGNAGE

A metal or plastic identification plate shall be permanently mounted to the exterior of the building at a minimum height of eight (8) feet above grade directly in line with the exhaust vent terminal for the horizontally vented gas fueled heating appliance or equipment. The sign shall read, in print size no less than one-half (1/2) inch in size, **"GAS VENT DIRECTLY BELOW, KEEP CLEAR OF ALL OBSTRUCTIONS"**.

INSPECTION

The state or local gas inspector of the side wall horizontally vented gas fueled equipment shall not approve the installation unless, upon inspection, the inspector observes carbon monoxide detectors and signage installed in accordance with the provisions of 248 CMR 5.08(2)(a)1 through 4.

Exemptions

The following equipment is exempt from 248 CMR 5.08(2)(a)1 through 4:

- The equipment listed in Chapter 10 entitled "Equipment Not Required To Be Vented" in the most current edition of NFPA 54 as adopted by the Board; and
- Product Approved side wall horizontally vented gas fueled equipment installed in a room or structure separate from the dwelling, building or structure used in whole or in part for residential purposes.

MANUFACTURER REQUIREMENTS

GAS EQUIPMENT VENTING SYSTEM PROVIDED

When the manufacturer of Product Approved side wall horizontally vented gas equipment provides a venting system design or venting system components with the equipment, the instructions provided by the manufacturer for installation of the equipment and the venting system shall include:

- Detailed instructions for the installation of the venting system design or the venting system components; and
- A complete parts list for the venting system design or venting system.

GAS EQUIPMENT VENTING SYSTEM NOT PROVIDED

When the manufacturer of a Product Approved side wall horizontally vented gas fueled equipment does not provide the parts for venting the flue gases, but identifies "special venting systems", the following requirements shall be satisfied by the manufacturer:

- The referenced "special venting system" instructions shall be included with the appliance or equipment installation instructions; and
- The "special venting systems" shall be Product Approved by the Board, and the instructions for that system shall include a parts list and detailed installation instructions.

A copy of all installation instructions for all Product Approved side wall horizontally vented gas fueled equipment, all venting instructions, all parts lists for venting instructions, and/or all venting design instructions shall remain with the appliance or equipment at the completion of the installation.

Limited Warranty

VENT-FREE HEATERS

United States Stove Company warrants to the original purchaser its products against premature failure of any component due to workmanship, quality, or materials as follows:

TIME PERIOD:

Controls/Valves	One Year From Time Of Purchase
Thermocouple/Thermopile	One Year From Time Of Purchase
All Electrical Components	One Year From Time Of Purchase
Combustion Chamber and Burner	Five Years From Time Of Purchase

CLAIM PROCEDURE

Any defects should be reported to United States Stove Company or its dealer and/or distributor giving descriptions and pertinent data, including proof or purchase which will be returned upon request.

Providing the heater has been installed and used in accordance with the Owners Manual supplied with the heater, United States Stove Company will either:

- 1) Replace the defective part free of charge
- 2) Replace the heater free of charge
- 3) Where the defect is of a cosmetic (non-functional) nature, United States Stove Company will bear reasonable expense to refurbish the heater, including such items as welding, painting, and incidental labor. A "Reasonable" is defined by terms of this warranty as \$30.00/hour with full refund for any purchase of parts.

NOT COVERED

Specifically not covered under terms of this limited warranty or any other warranty are problems relating to smoking or creosote. Smoking is attributable to inadequate draft due to the design or installation of the flue system or installation of the heater itself. Creosote formation is largely attributable to improper operation of the unit and/or draft as mentioned above. Also, not covered are:

- 1) Removal and re-installation cost.
- 2) Service calls to diagnose trouble (unless authorized in writing by the manufacturer, distributor, or dealer).
- 3) Damage or defect caused by improper installation, accidents, misuse, abuse (including overfiring) or alteration.
- 4) Transportation or shipping costs.

LIMITATIONS AND EXCLUSIONS

- 1) United States Stove Company shall not be liable for incidental, consequential, special, or contingent damages anyone might suffer as a result of their breach of this written warranty or any implied warranty.
- 2) Should the heater be replaced by United States Stove Company "free of charge", all further warranty obligations are thereby met.
- 3) Parts and/or service replacements made under the terms of this warranty are warranted only for the remaining period of the original heater warranty.
- 4) Without specific written exclusionary waivers, no one has authority to add to or vary this limited warranty, or to create for United States Stove Company any further obligation of liability in connection with this heater or any other applicable accessory. Any further warranty implication applicable to this heater or any applicable accessory is limited in duration to the same time period as the original statement in the above schedule.

YOUR DUTIES

- 1) This heater, including all applicable accessories, must be installed and operated in accordance with local authorities having jurisdiction and the instructions furnished with the Owners Manual.
- 2) You should keep as permanent record your proof of purchase (or canceled check or invoice).

PROBLEM/RESOLUTION

- 1) As purchaser, you must first contact the dealer and/or distributor from whom you purchased your heater.
- 2) If within a reasonable period of time you do not receive satisfactory service from the distributor and/or dealer, write or call United States Stove Company, Customer Service Department, including complete details of the problem and/or problems you are experiencing, details of your installation, your proof of purchase, and the heater serial number or test agency code number.

WARRANTOR

The warrantor of record is United States Stove Company, PO Box 151, 227 Industrial Drive, South Pittsburg, Tennessee 37380.

Phone number: 800-750-2723.

NOTE

This warranty gives you specific legal rights; and, you may also have other rights which vary from state to state.

IMPORTANT

Keep this warranty card for future reference.

We congratulate you on your selection of United States Stove Company and its products. As the oldest solid fuel manufacturer in the United States (since 1869), the United States Stove Company is very proud of its products, service, employees, and satisfied customers. As President of United States Stove Company, I would like to hear from you if you are not satisfied with the manner in which you have been handled by our distributor, dealer, representative, customer service department, parts department, or sales department. Please write me at the above address.

Sincerely

Richard Rogers, President

KEEPING AMERICA WARM SINCE 1869

website: www.usstove.com

NOTES

NOTES

HOW TO ORDER REPAIR PARTS

THIS MANUAL WILL HELP YOU OBTAIN EFFICIENT, DEPENDABLE SERVICE FROM YOUR APPLIANCE DEALER, AND ENABLE YOU TO ORDER REPAIR PARTS CORRECTLY.

KEEP THIS MANUAL IN A SAFE PLACE FOR FUTURE REFERENCE.

WHEN WRITING, ALWAYS GIVE THE FULL MODEL NUMBER WHICH IS ON THE NAMEPLATE ATTACHED TO THE HEATER.

WHEN ORDERING REPAIR PARTS, ALWAYS GIVE THE FOLLOWING INFORMATION AS SHOWN IN THIS LIST:

1. THE PART NUMBER _____
2. THE PART DESCRIPTION _____
3. THE MODEL NUMBER _____
4. THE SERIAL NUMBER _____



United States Stove Company
227 Industrial Park Road
P.O. Box 151
South Pittsburg, TN 37380
(800) 750-2723
WWW.USSTOVE.COM

CUT HERE



WARRANTY INFORMATION CARD

Name _____ Telephone #: (_____) _____

City _____ State _____ Zip _____

Email Address _____

Model # of Unit _____ Serial # _____

Fuel Type: Wood Coal Pellet Gas Other _____

Place of Purchase (Retailer) _____

City _____ State _____ Zip _____

If internet purchase, please list website address _____

Date of Purchase _____

Reason for Purchase: Alternative Heat Main Heat Source

Decoration Cost Other _____

What was the determining factor for purchasing your new appliance? _____

I have read the owner's manual that accompanies this unit and fully understand the:
Installation Operation and Maintenance of my new appliance.

Print Name

Signature

Date

Please attach a copy of your purchase receipt.

Warranty not valid without a Proof of Purchase.

Warranty information must be received within 30 days of original purchase.

Detach this page from this manual, fold in half with this page to the inside and tape together. Apply a stamp and mail to the address provided. You may use an envelope if you choose.

You may register online by going to www.usstove.com

All information submitted will be kept strictly confidential. Information provided will not be sold for advertising purposes.
Contact information will be used solely for the purpose of product notifications.

CUT HERE



CUT HERE



CUT HERE



 Fold Here

Fold Here 

PLACE
STAMP
HERE

United States Stove Company
P.O. Box 151
South Pittsburg, TN 37380