

Operation

1 Operating the angle die grinder

- This Angle Die Grinder is designed to operate on 90 PSIG. Lower pressure (below 90 PSIG) will reduce performance of the tool. Higher air pressure (over 90 PSIG) raises the performance of the tool beyond its rated capacity and could cause serious damage to the tool and the user.
- To operate the tool, press the lever and push the safety bar.

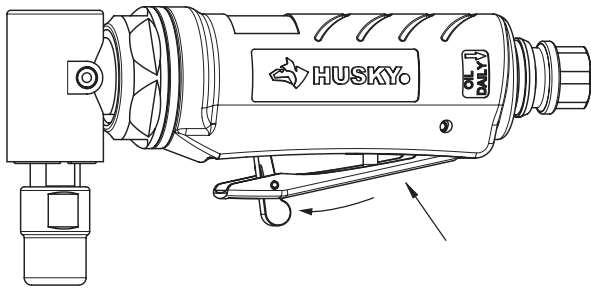

2 Installing the mounted points



WARNING: Disconnect the tool from the air supply before servicing or changing accessories.

- Only use 1/4" ANSI standard mounted stones or carbide burrs rated at or above 20000 RPM.
- Push the shaft of the stone or burr fully into the inside of the collet.
- Hold the die grinder spindle with the smaller spanner wrench (B) and tighten the collet nut with the larger spanner wrench (B).

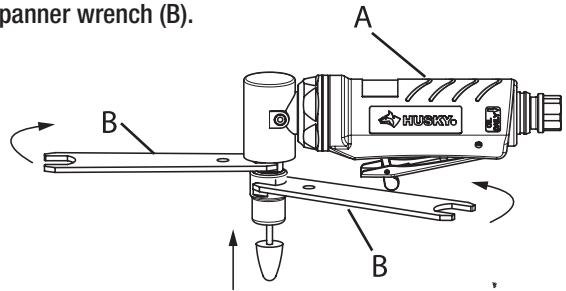

3 Removing the mounted points



WARNING: Disconnect the tool from the air supply before servicing or changing accessories.

- Hold the die grinder spindle with the smaller spanner wrench (B) and un-tighten the collet nut with the larger spanner wrench (B).
- Remove the accessory from the die grinder.

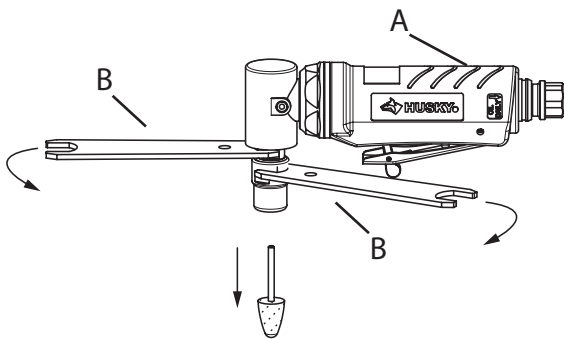

4 Grinding and deburring

- Connect the angle die grinder to the air supply.
- Hold the die grinder in one hand and start the rotation by operating the throttle lever.
- Place the stone or burr on the work area and gradually apply pressure to achieve the desired amount of material removal.

