



Item # 1001 868 807  
Model # FTM70552

## USE AND CARE GUIDE

---

### STATESVILLE COFFEE TABLE WITH GLASS TOP



Questions, problems, missing parts? Before returning to the store  
call Hampton Bay Customer Service.  
8 a.m. - 7 p.m., EST, Monday - Friday, 9 a.m. - 6 p.m., EST, Saturday

**1-855-HD-HAMPTON**

**HAMPTONBAY.COM**

---

#### **THANK YOU**

*We appreciate the trust and confidence you have placed in Hampton Bay through the purchase of this table. We strive to continually create quality products designed to enhance your home. Visit us online to see our full line of products available for your home improvement needs. Thank you for choosing Hampton Bay!*

# Table of Contents

Table of Contents .....	2	Pre-Assembly .....	3
Safety Information .....	2	Planning Assembly .....	3
Product Caution .....	2	Hardware Included .....	3
Safety Warnings .....	2	Package Contents .....	4
Warranty .....	2	Assembly .....	5
What is Covered .....	2	Care and Cleaning .....	7
What is Not Covered .....	2		

# Safety Information

## PRODUCT CAUTION

This table was made for the explicit purpose of providing outdoor functions and is not to be used as a toy. This product is intended for normal outdoor use; however, the manufacturer recommends storing and / or covering this table when any formidable / severe weather is approaching. Do not locate the product near open flame. Do not use the product as a support. Do not shake, lean or climb on the product. Children under the age of 10, near the product, should be supervised by a competent adult at all times. This product is NOT intended for commercial use and will void the warranty.

## SAFETY WARNINGS

 **WARNING:** Do not place heavy objects on the table top.

 **CAUTION:** When not in use, secure the product in a cool and covered location.

 **WARNING:** Please keep children out of the assembly area before assembly.

# Warranty

## 2 YEAR FRAME LIMITED WARRANTY

### WHAT IS COVERED

We warrant the frames to be free of manufacturing defects to the original purchaser for two years.

### WHAT IS NOT COVERED

It remains the customer's responsibility for freight and packaging charges to and from our service center. This warranty does not cover commercial use, hardware, acts of nature, fire, freezing and abusive use. In addition, purchased parts are not covered under this warranty. We reserve the right to make substitutions with similar merchandise, if the model in question is no longer in production.

Contact the Customer Service Team at 1-855-HD-HAMPTON or visit [www.HamptonBay.com](http://www.HamptonBay.com).

# Pre-Assembly

## PLANNING ASSEMBLY

Read all instructions before assembly.

To avoid damaging this product, assemble it on a soft, non-abrasive surface such as carpet or cardboard.



**NOTE:** More than one person may be required to assemble this product.

## HARDWARE INCLUDED



**NOTE:** Hardware not shown to actual size.



\_\_\_\_\_ AA



\_\_\_\_\_ BB



\_\_\_\_\_ DD

Part	Description	Quantity
AA	M6x15 combination bolt	8+1
BB	M6x25 combination bolt	8+1
CC	Hex Wrench	1

# Pre-Assembly (continued)

## PACKAGE CONTENTS

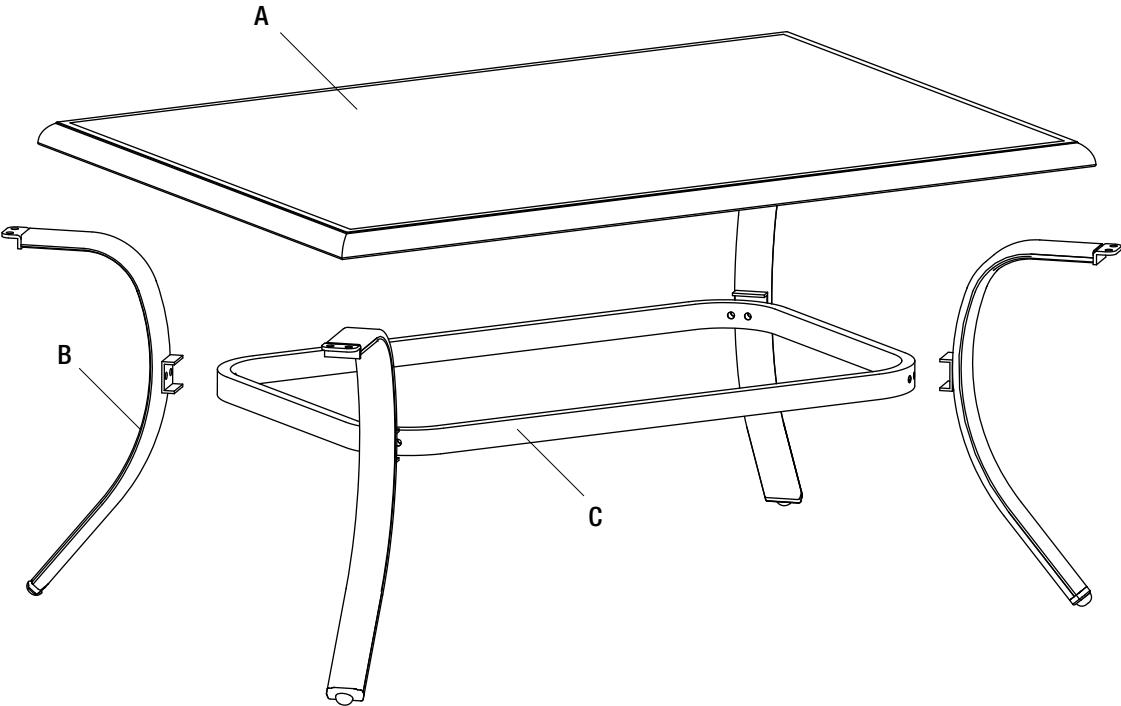

Part	Description	Quantity
A	Table top	1
B	Table leg	4
C	Leg connector	1

# Assembly

## 1 CONNECTING THE TABLE LEGS TO THE TABLE TOP

- Place the table top (A) upside down on a soft surface.
- Attach the table legs (B) to the table top (A) using M6x15 combination bolts (AA).



**NOTE:** Loosely tighten all the bolts using the hex wrench (CC).

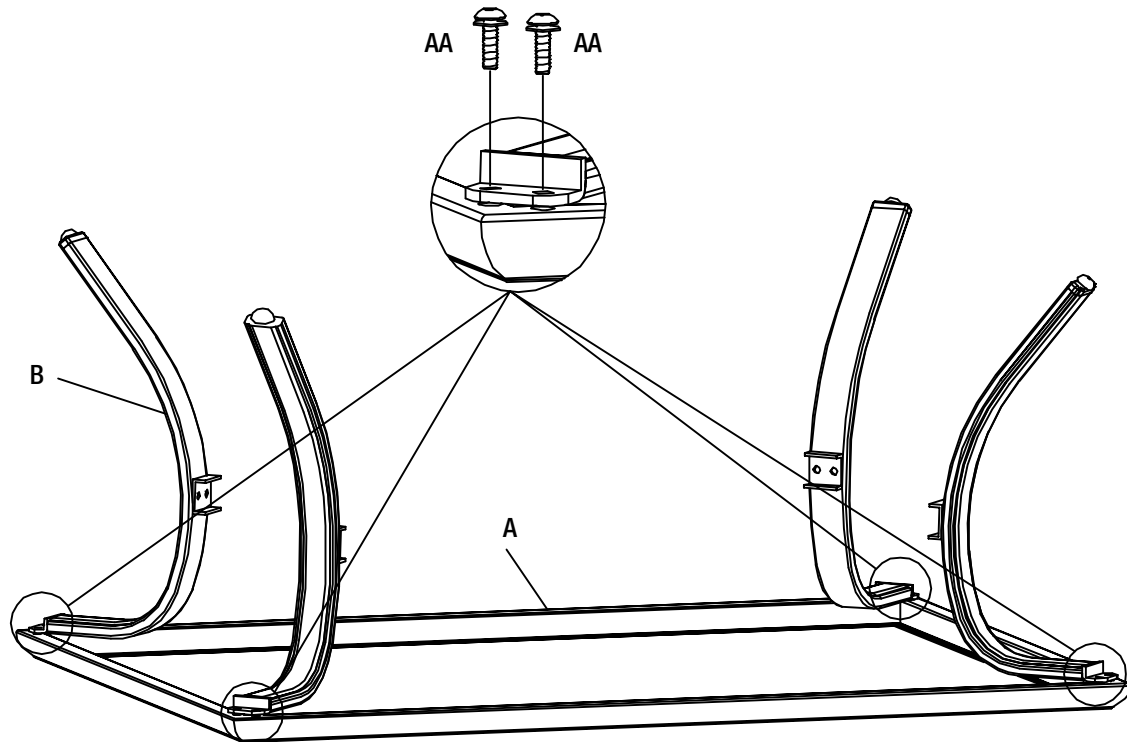

## Assembly (continued)

### 2 CONNECTING THE LEG CONNECTOR TO THE TABLE LEGS

- Assemble the leg connector (C) to the table legs (B) using M6x25 combination bolts (BB).
- Once all of the bolts are in place, fully tighten the bolts using the hex wrench (CC).

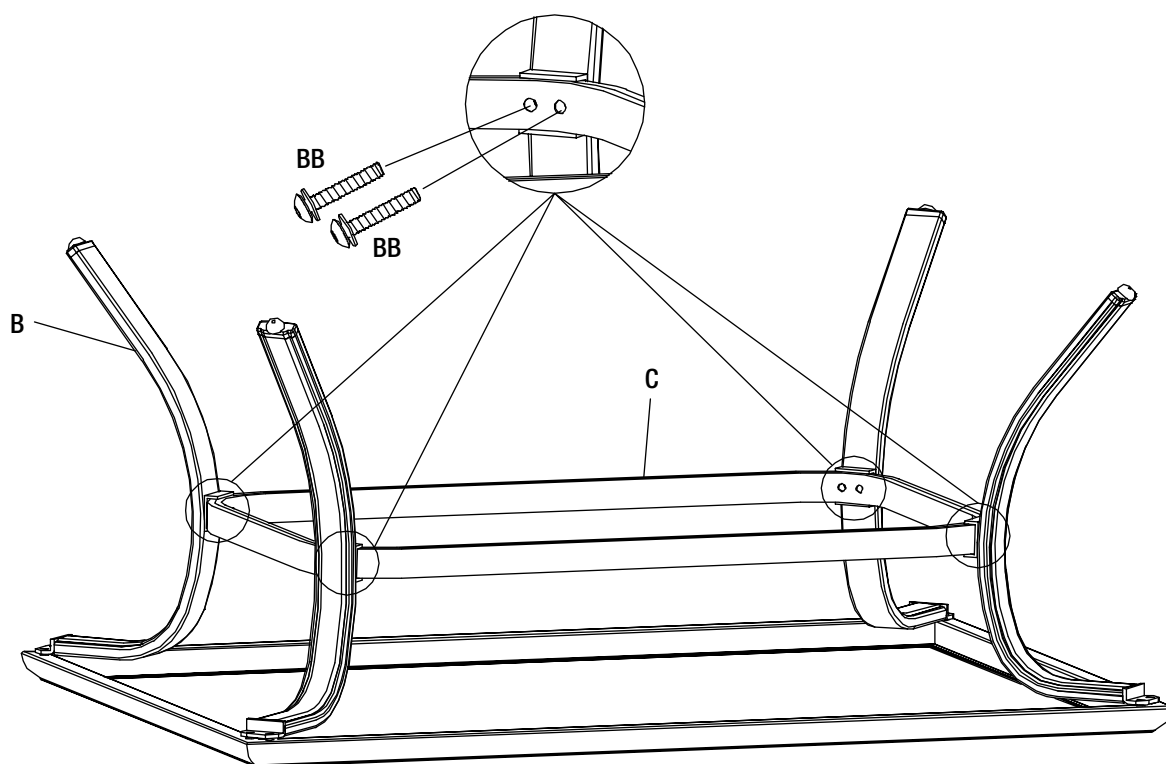

## Assembly (continued)

### 3 COMPLETING THE ASSEMBLY

- Turn the table right side up
- Ensure all connections are secure before use.



## Care and Cleaning

- For best results, clean the frame with a damp cloth and dry thoroughly. This will help prevent mildew by removing dirt particles that may accumulate.
- Do not clean with abrasive materials, bleach, or solvents.
- Store the table in a dry, sheltered place when not in use.
- Keep the table away from fire, extreme heat, freezing conditions, and inclement weather such as rain, hail, sleet, snow, or wind.



Questions, problems, missing parts? Before returning to the store,  
call Hampton Bay Customer Service.  
8 a.m. - 7 p.m., EST, Monday - Friday, 9 a.m. - 6 p.m., EST, Saturday

**1-855-HD-HAMPTON**

**HAMPTONBAY.COM**

Retain this manual for future use.