

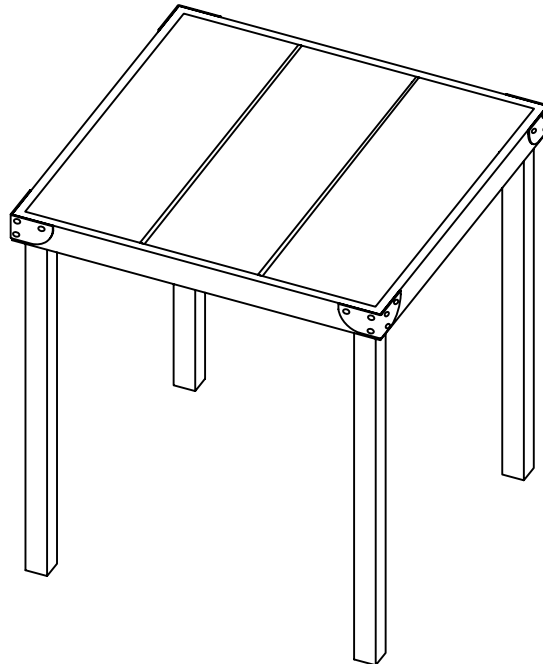

YOW SKU # 698 987
Model #D11215-TB

USE AND CARE GUIDE

VERNON HILLS 25" BISTRO TABLE



Questions, problems, missing parts? Before returning to the store,

call Hampton Bay Customer Service

8 a.m. - 7 p.m., EST, Monday-Friday

9 a.m. - 6 p.m., EST, Saturday

1-855-HD-HAMPTON

HAMPTONBAY.COM

THANK YOU

We appreciate the trust and confidence you have placed in Hampton Bay through the purchase of this table. We strive to continually create quality products designed to enhance your home. Visit us online to see our full line of products available for your home improvement needs. Thank you for choosing Hampton Bay!

Table of Contents

Table of Contents.....	2	Assembly.....	5
Safety Information.....	2	Care and Cleaning.....	6
Warranty.....	2		
What is Covered.....	2		
What is Not Covered.....	2		
Pre-Assembly.....	3		
Planning Assembly.....	3		
Hardware Included.....	3		
Table Package Contents.....	4		

Safety Information



WARNING: Do not sit or stand on the table top.



WARNING: Do not place heavy items on the table top.

Warranty

THIS IS A RESIDENTIAL WARRANTY ONLY AND THIS WARRANTY DOES NOT APPLY TO COMMERCIAL USE

2-YEAR FRAME LIMITED WARRANTY

WHAT IS COVERED

We warrant the frame to be free of manufacturing defects to the original purchaser for two years.

WHAT IS NOT COVERED

It remains the customer's responsibility for freight and packaging charges to and from our service center.

This warranty does not cover commercial use, hardware, acts of nature, fire, freezing and abusive use.

In addition, purchased parts are not covered under this warranty. We reserve the right to make substitutions with similar merchandise, if the model in question is no longer in production.

For a copy of our full limited warranty, please contact our customer service team below.
Contact the Customer Service Team at 1-855-HD-HAMPTON or visit www.hamptonbay.com.

Pre-Assembly

PLANNING ASSEMBLY

Please read this entire instruction manual prior to assembly. Identify all parts packed in the carton against the parts list. Remove all protective materials and place the parts on a non-abrasive surface to avoid scratching.

 **NOTE:** More than one person may be required to complete the assembly of this product.

HARDWARE INCLUDED

 **NOTE:** Tools not shown to actual size.

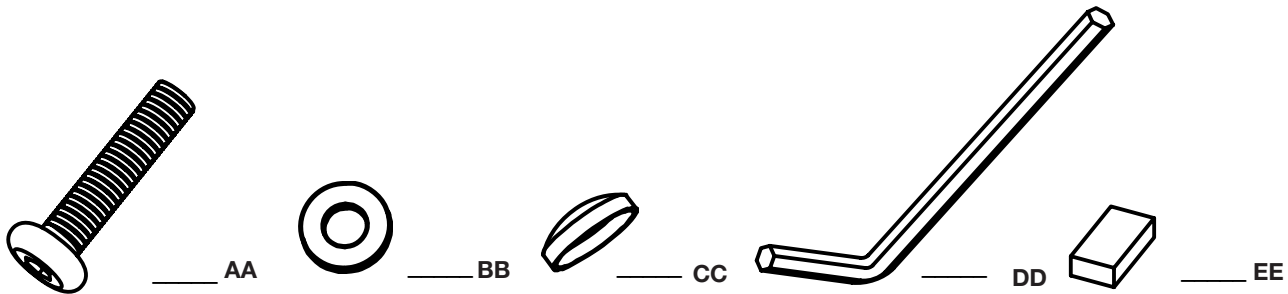

Part	Description	Quantity
AA	M6x25mm Allen bolts	8
BB	M6 Washers	8
CC	Bolt caps	8
DD	Allen Wrench	1
EE	Bumpers	35

Pre-Assembly (continued)

TABLE PACKAGE CONTENTS

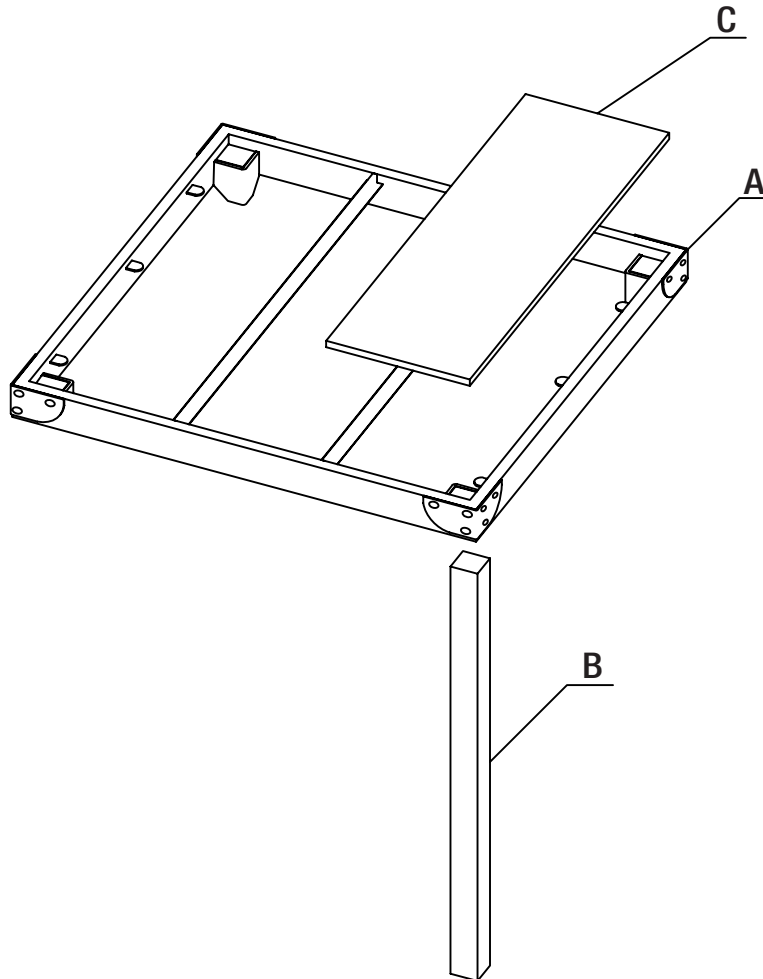

Part	Description	Quantity
A	Table frame	1
B	Table legs	4
C	Top tiles	3

Assembly

1 Attaching the table legs

- Place the table frame (A) on a soft, flat non-abrasive surface. Attach the table legs (B) to the table frame (A) using the allen bolts (AA) and M6 washers (BB).
- Tighten the bolts (AA) with the allen wrench (DD).
- Attach the bolt caps (CC) to the allen bolts (AA).

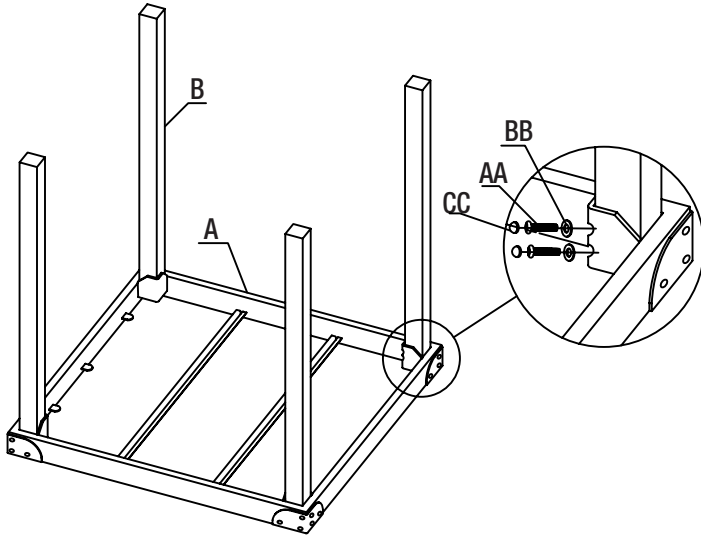

2 Attaching the bumpers

- Turn the table over and set it down on its legs (B).
- Attach the bumpers (EE) on table frame (A).
- 17 bumpers (EE) for spare parts.

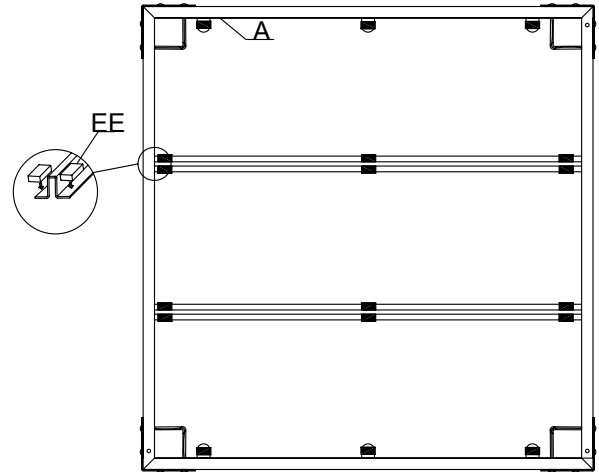

3 Positioning the top tile

- Place one top tile (C) on table frame (A).

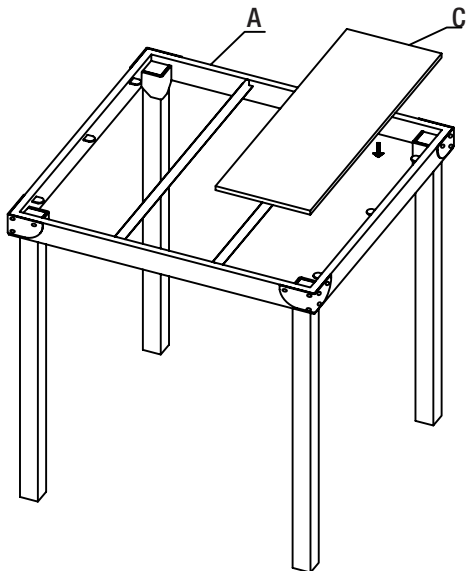

4 Positioning the table

- Place another two top tiles (C) into the table frame (A).
- The table is now ready for use.

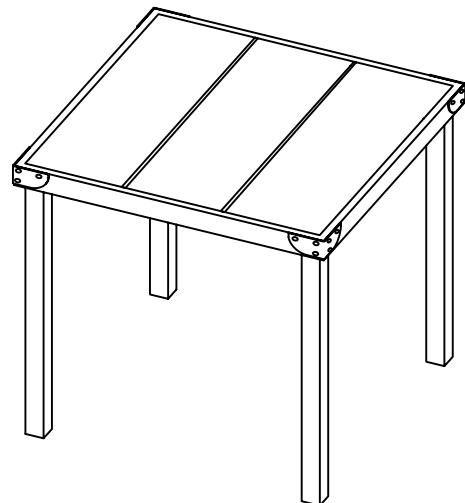

Care and Cleaning

- Do not allow water to build up in the frames. This will cause corrosion and possible freezing damage in cold climates.
- Use a mild soap and water for normal cleaning. Do not use janitorial or alcohol based cleaners. Some cleaners may be marked as natural, but some ingredients may cause discoloration or have an adverse reaction to your finish.
- Rinse with clean water and dry with a soft, absorbent cloth towel.
- Treat frames with a liquid wax for maximum protection against UV rays and/or salty, damp air.



Questions, problems, missing parts? Before returning to the store,

call Hampton Bay Customer Service

8 a.m. - 7 p.m., EST, Monday-Friday

9 a.m. - 6 p.m., EST, Saturday

1-855-HD-HAMPTON

HAMPTONBAY.COM

Retain this manual for future use.