

Assembly Instructions

Item: HW56629

0.5hr

APPROXIMATE ASSEMBLY TIME 1 PEOPLE OF ASSEMBLY



**FLOOR AREA
1.0Mx1.M**



REQUIRED ASSEMBLY SPACE

REQUIRED ASSEMBLY TOOLS

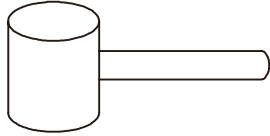

SOFT RUBBER HAMMER(Not Provided)

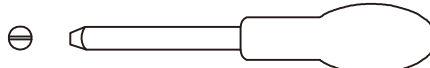

SLOTTED SCREWDRIVER(Not Provided)

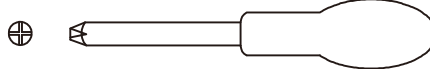

POZI SCREWDRIVER(Not Provided)

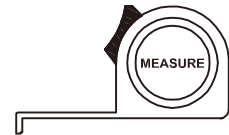





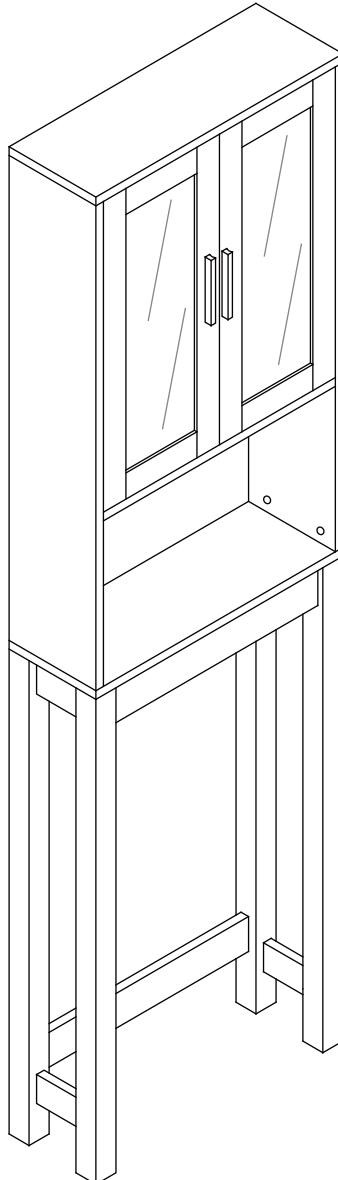



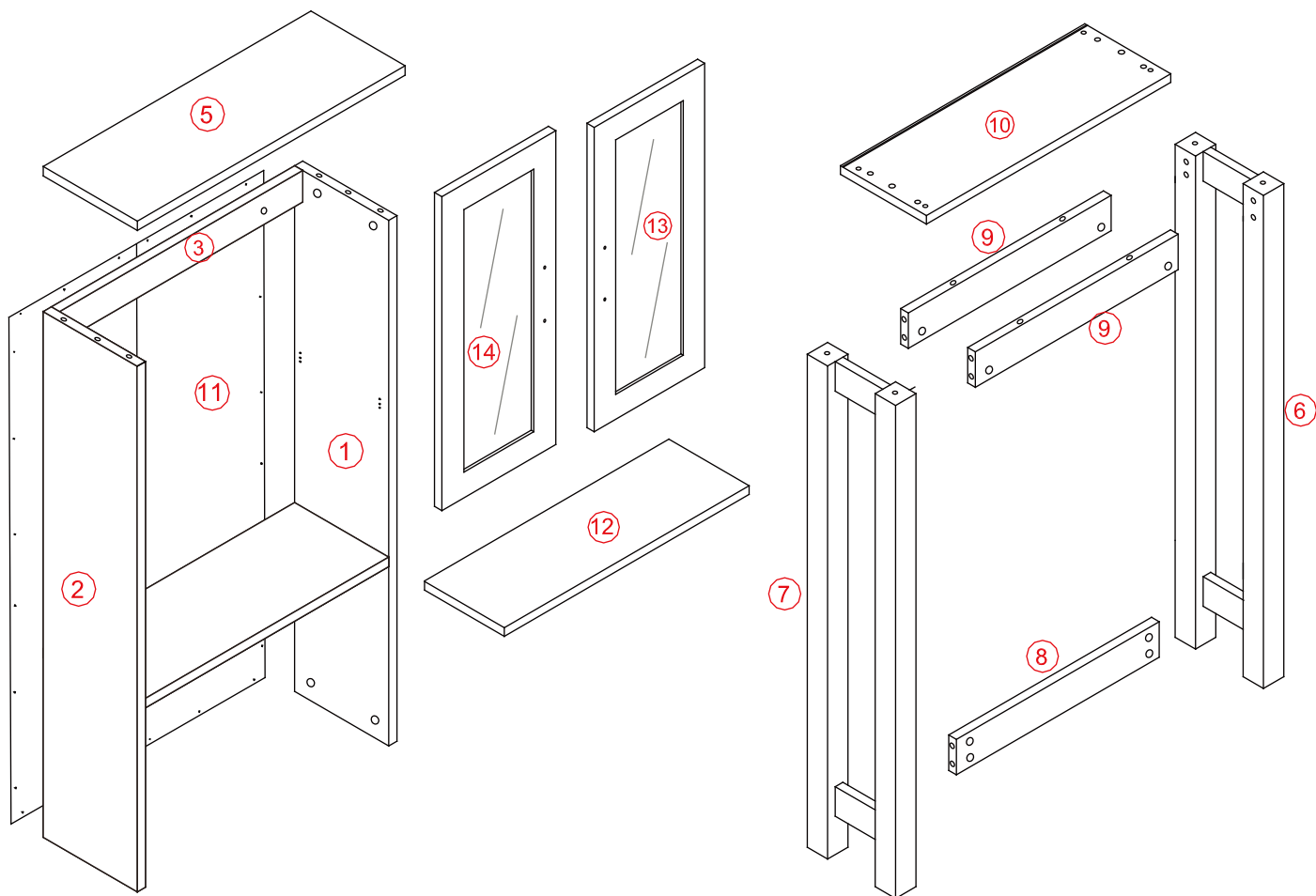



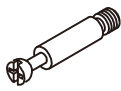

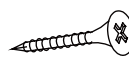

MEASURING TAPE (Not Provided)

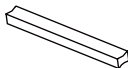
ASSEMBLED DIMENSIONS

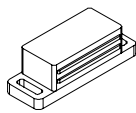

1-8

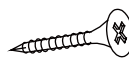

A  x20	B  x20	C  Ø6x30mm x18	D  Ø4x30mm x4
E  Ø3x12mm x18	F  x4	G  Ø2.5x10mm x24	H  Ø3x12mm x4
I  x2	J  x2	K  x1	L  x4
M  x2	N  x4	O  Ø4x35mm x2	P 
Q  Ø3x15mm x2	2-8		

STEP 1

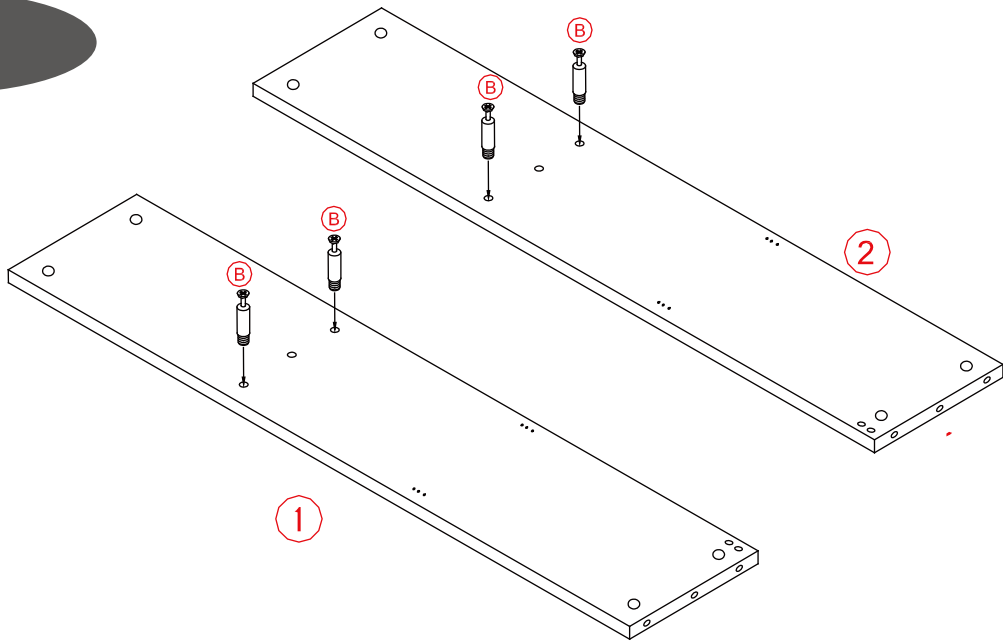

STEP 2

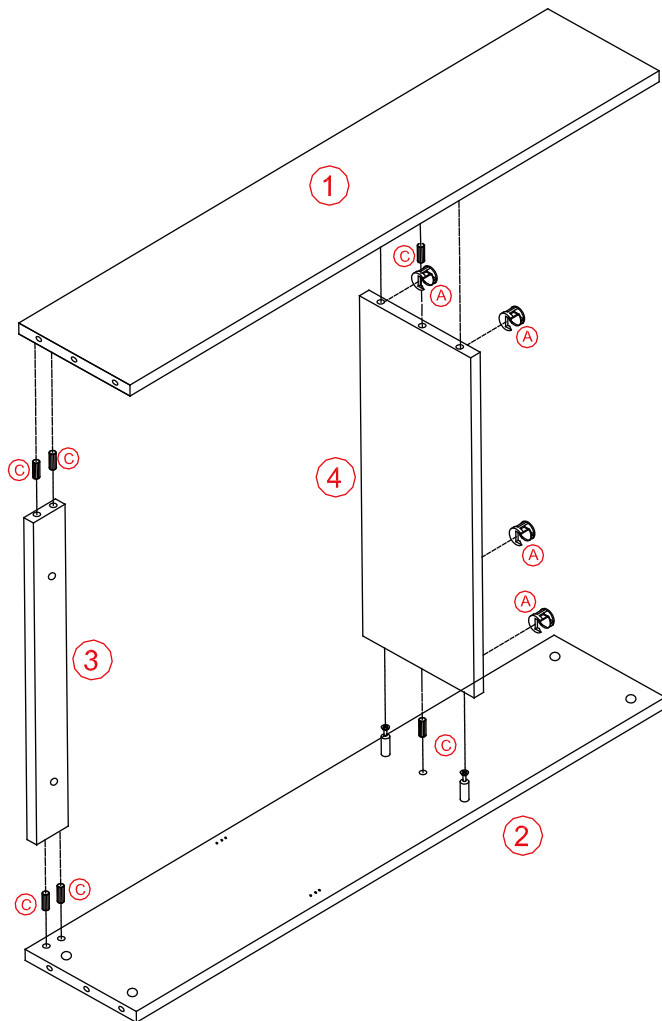

STEP 3

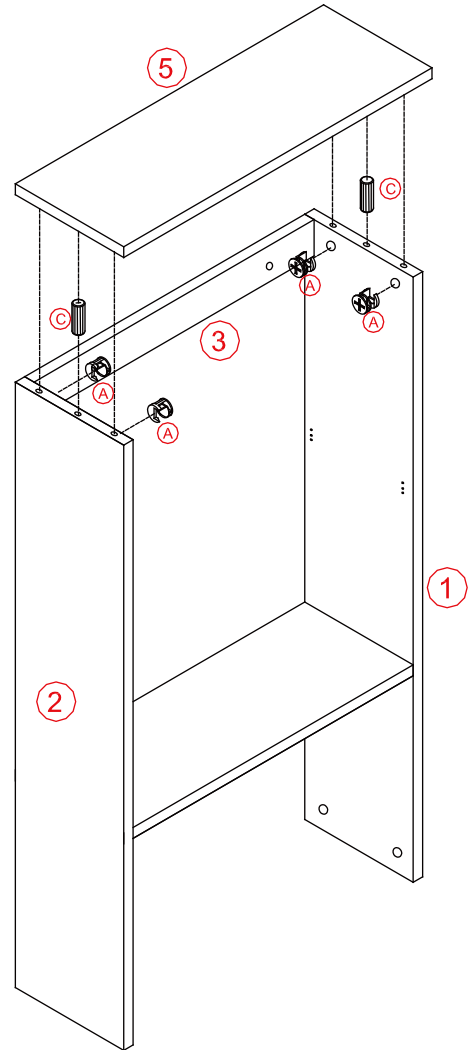
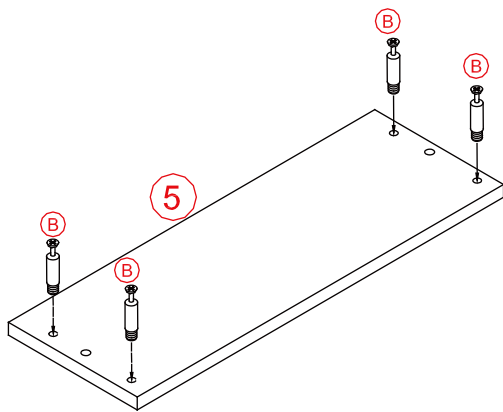

STEP 4

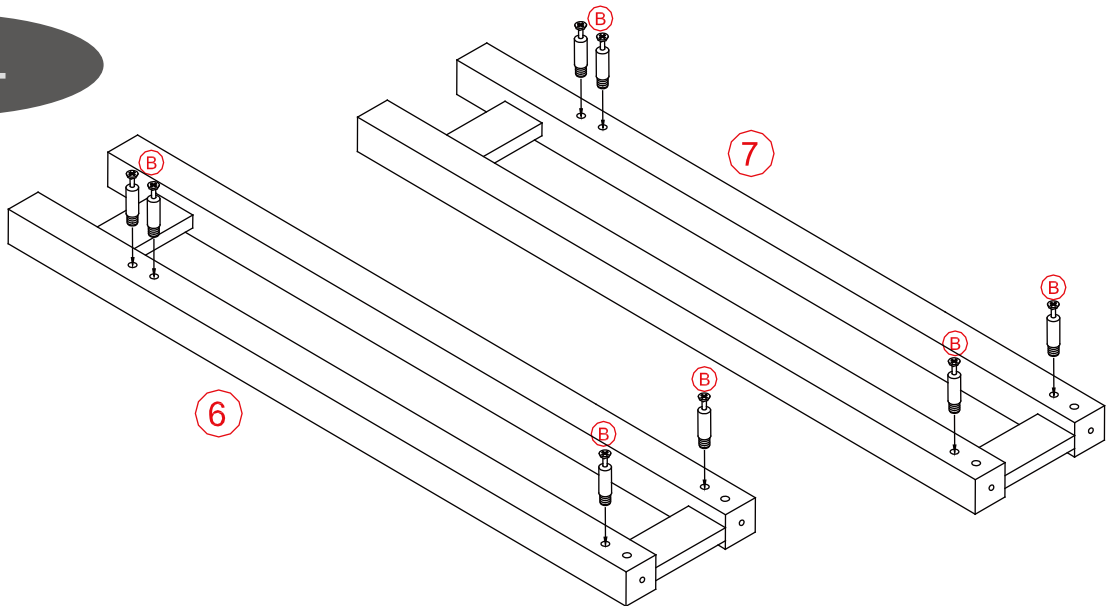

STEP 5

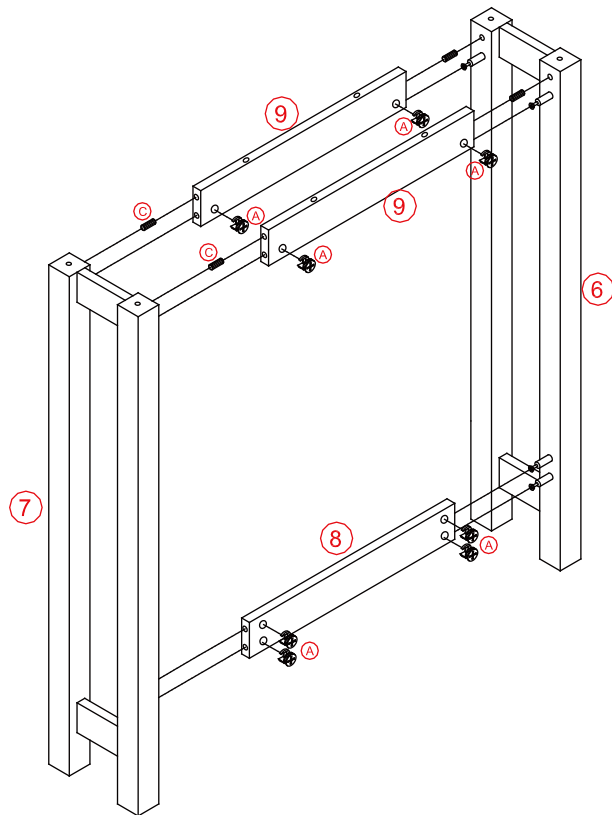

STEP 6

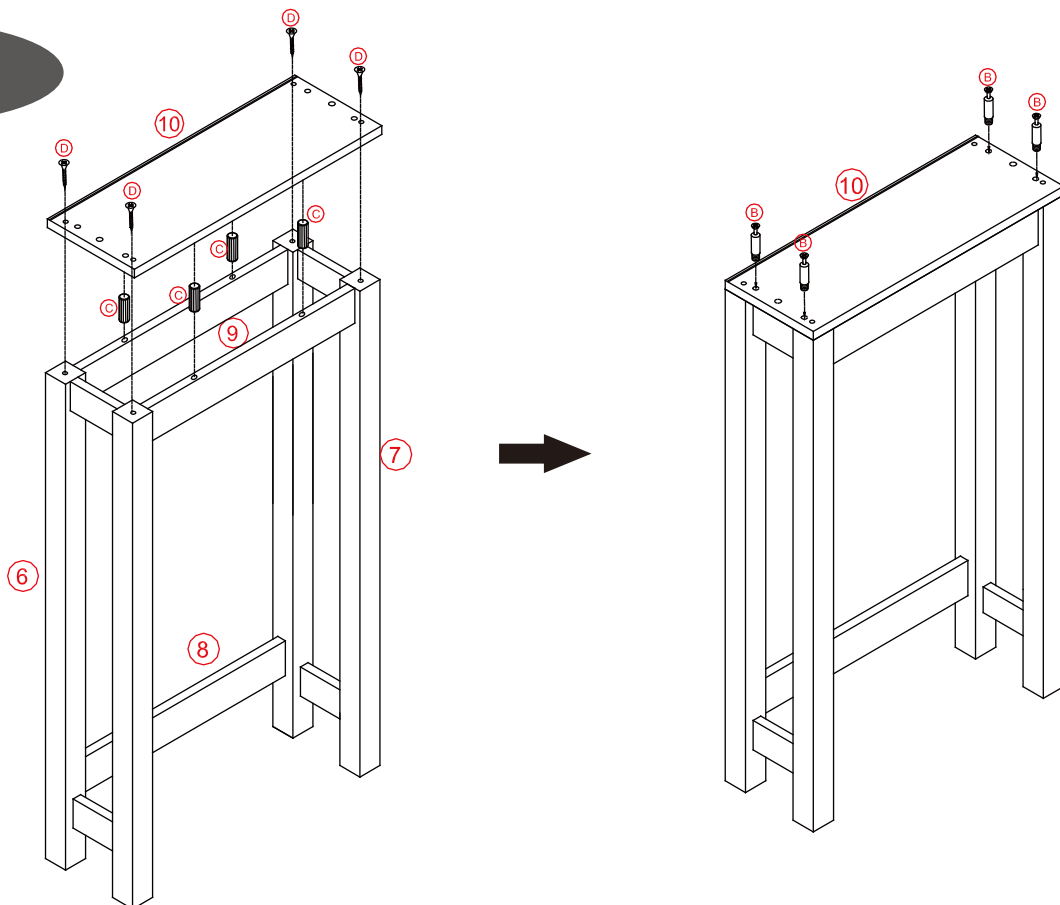

STEP 7

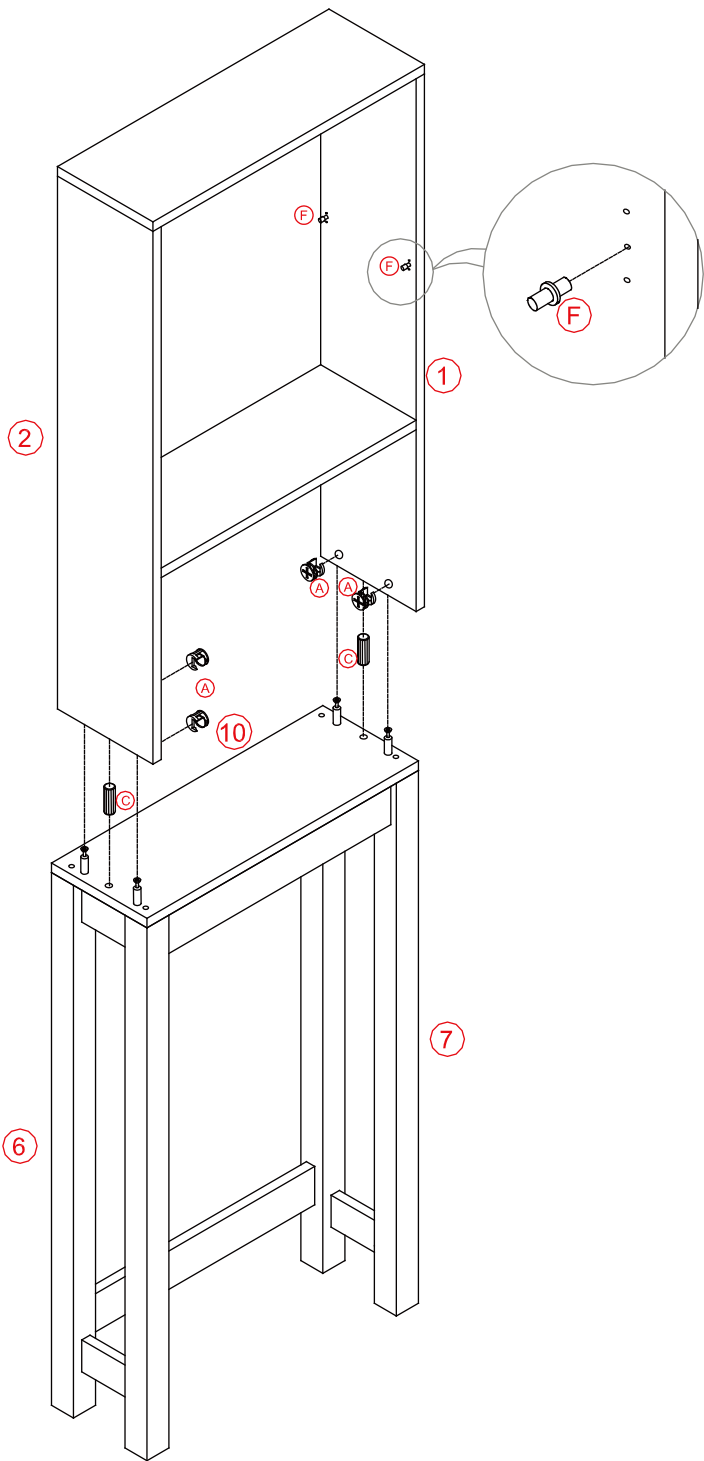

STEP 8

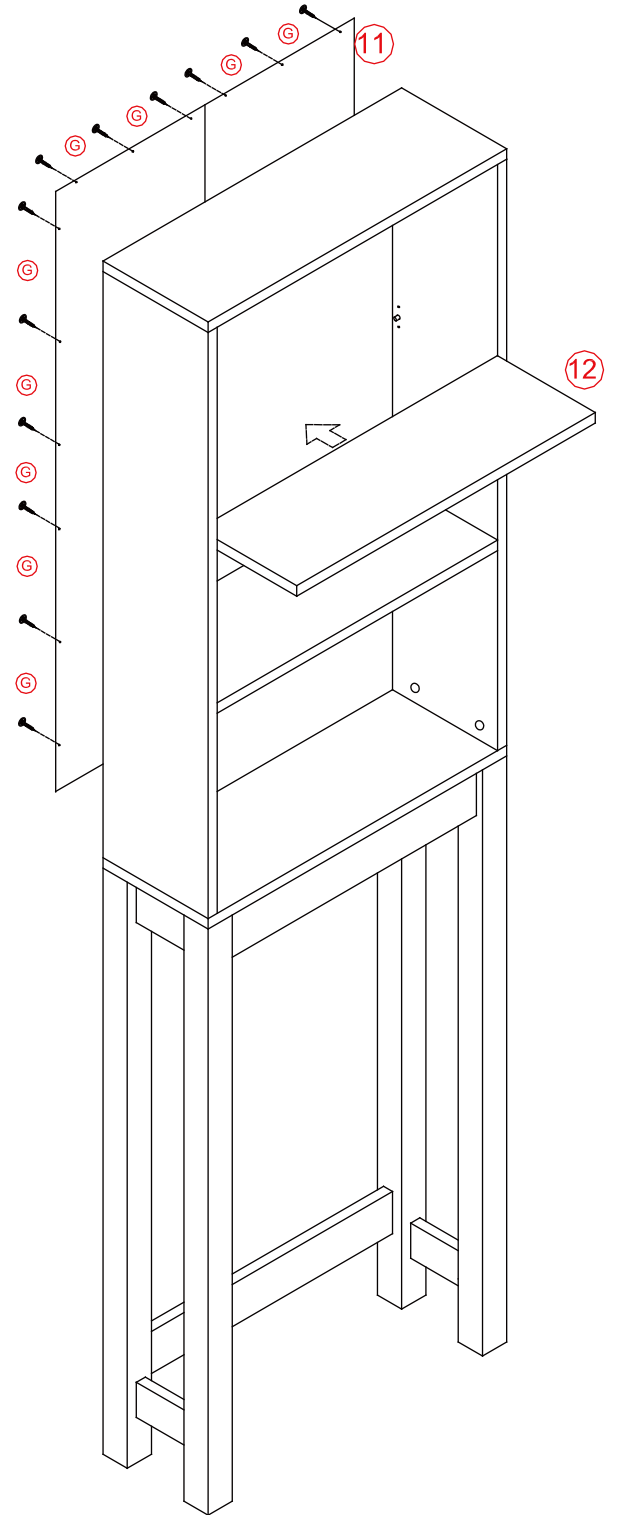

STEP 9

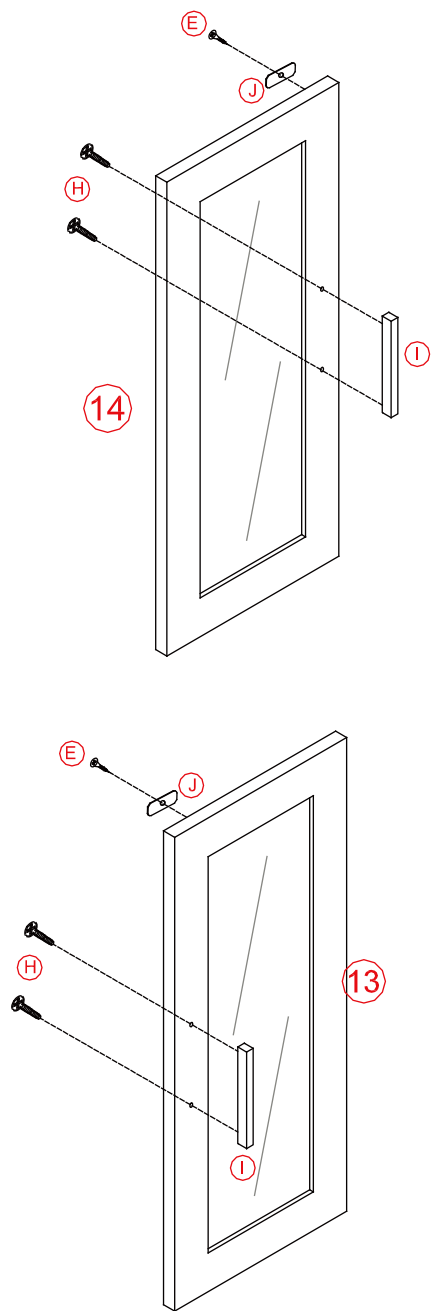

STEP 10

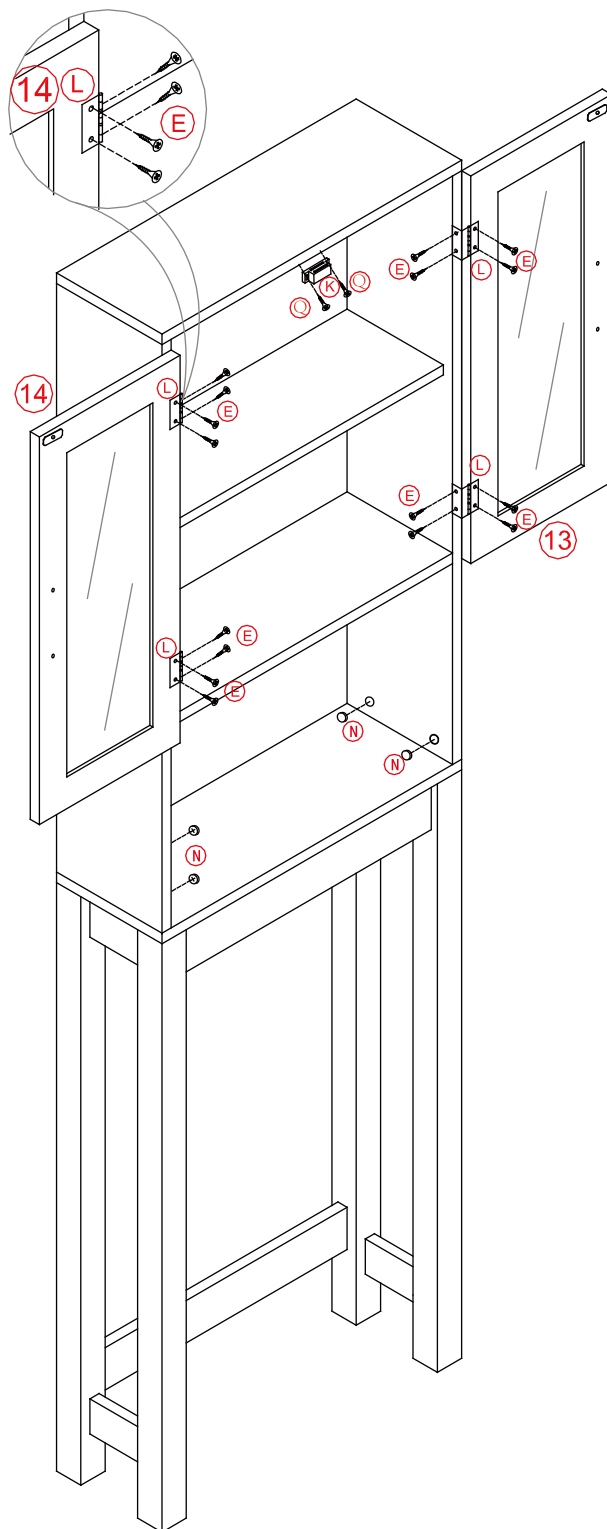

STEP 11

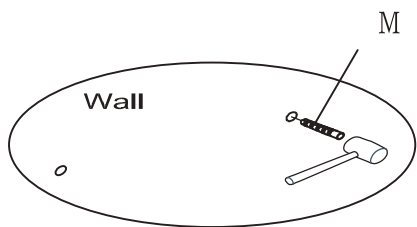
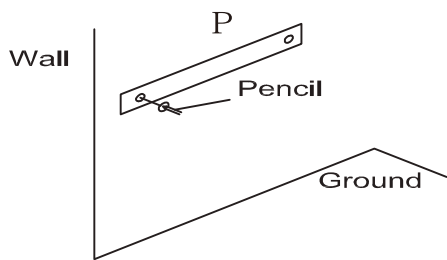

STEP 12

